

ONDA

GIULIO BARBIERI
OUTDOOR SOLUTIONS

OUTDOOR LIVING SPACES





ONDA120



ONDA120





ONDA90
WATERPROOF



ONDA120



ONDA120



ONDA120



ONDA90

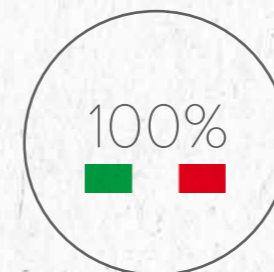
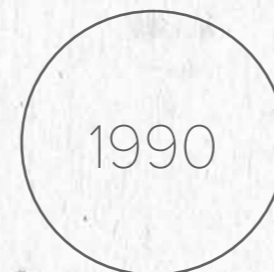
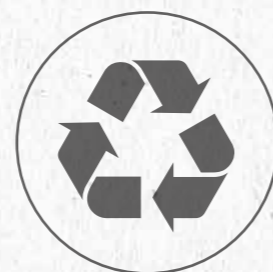
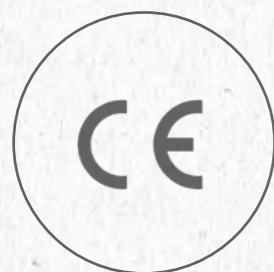

WARRANTY AND QUALITY

- All of our structures' components are CE certified.
- Flame retardancy certificates are provided for all kind of PVC fabrics.
- Structures are checked for load capacity in accordance with EN 13782, DM 17th January 2018 Technical Standards for Constructions and UNI EN 1991.
- Products have a legal warranty of 5 years.

GARANZIA E QUALITÀ

- I singoli componenti delle strutture sono certificati CE.
- Vengono forniti i certificati di ignifugazione per ogni tipologia di telo utilizzato.
- Le strutture sono verificate ai carichi previsti dalle normative vigenti EN 13782, DM 17 Gennaio 2018 Norme Tecniche per le Costruzioni NTC e UNI EN 1991.
- Le strutture sono garantite 5 anni.

GARANTIE ET QUALITÉ

- Chaque composant des structures est certifié CE.
- Les certificats d'ignifugation sont fournis pour tout type de toile utilisée.
- Les structures sont vérifiées avec les charges prévues par les réglementations en vigueur EN 13782, DM 17 Janvier 2018 Normes Techniques pour les Constructions NTC et UNI EN 1991.
- Les structures sont garanties 5 ans.

GARANTIE UND QUALITÄT

- Die einzelnen Komponenten der Struktur haben das CE-Zertifikat.
- Zertifikate der Schwerentflammbarkeit sind für jede Art von Tuch vorgesehen.
- Die Strukturen werden auf Lasten geprüft, wie durch die geltenden Normen EN 13782, DM 17 Januar 2018 Technische Normen für das Bauen NTC und UNI EN 1991 vorgesehen sind.
- Die Strukturen sind für 5 Jahre garantiert.

GARANTÍA Y CALIDAD

- Los componentes individuales de las estructuras están certificados CE.
- Se entregan los certificados de propiedad ignífuga para cada tipo de lona utilizada.
- Las estructuras se ensayan con las cargas previstas en las normativas vigentes EN 13782, DM 17 de enero de 2018 Normas técnicas para las construcciones NTC y UNI EN 1991.
- Las estructuras están garantizadas por 5 años.

MADE IN ITALY

We are proud to have been manufacturing exclusively in Ferrara (Italy) since 1990.



- Dal 1990 produciamo rigorosamente nel nostro stabilimento di Ferrara, Italia.
- Depuis 1990, nous produisons exclusivement dans notre établissement de Ferrare, Italie.
- Seit 1990 sind unsere Produkte exklusiv in unseren Werken in Ferrara, Italien produziert.
- Desde 1990, fabricamos exclusivamente en nuestra planta de Ferrara (Italia).



ESSENTIALITY IS OUR STRENGTH

Our products are made to last:
we have created a clean and
functional design without
unnecessary automation and easily
degrading mechanisms.

L'ESSENZIALITÀ È LA NOSTRA FORZA

I nostri prodotti sono destinati a durare nel tempo: abbiamo creato un design pulito e funzionale senza inutili automatismi e meccanismi suscettibili di facile deterioramento.

LA SIMPLICITÉ EST NOTRE FORCE!

Nos produits ont été conçus pour durer dans le temps: nous avons créé un design simple et fonctionnel sans mécanismes superflues et susceptibles à détérioration.

WESENTLICHKEIT IST UNSERE STÄRKE

Unsere Produkte sind für eine lange Lebensdauer bestimmt: Wir haben ein sauberes und funktionelles Design ohne unnötige Automatisierung und leicht abnutzbare Mechanik geschaffen.

LA ESENCIALIDAD ES NUESTRA FUERZA

Nuestros productos están pensados para durar en el tiempo, hemos creado un diseño esencial y funcional sin automatismos y mecanismos que se pueden deteriorar fácilmente.

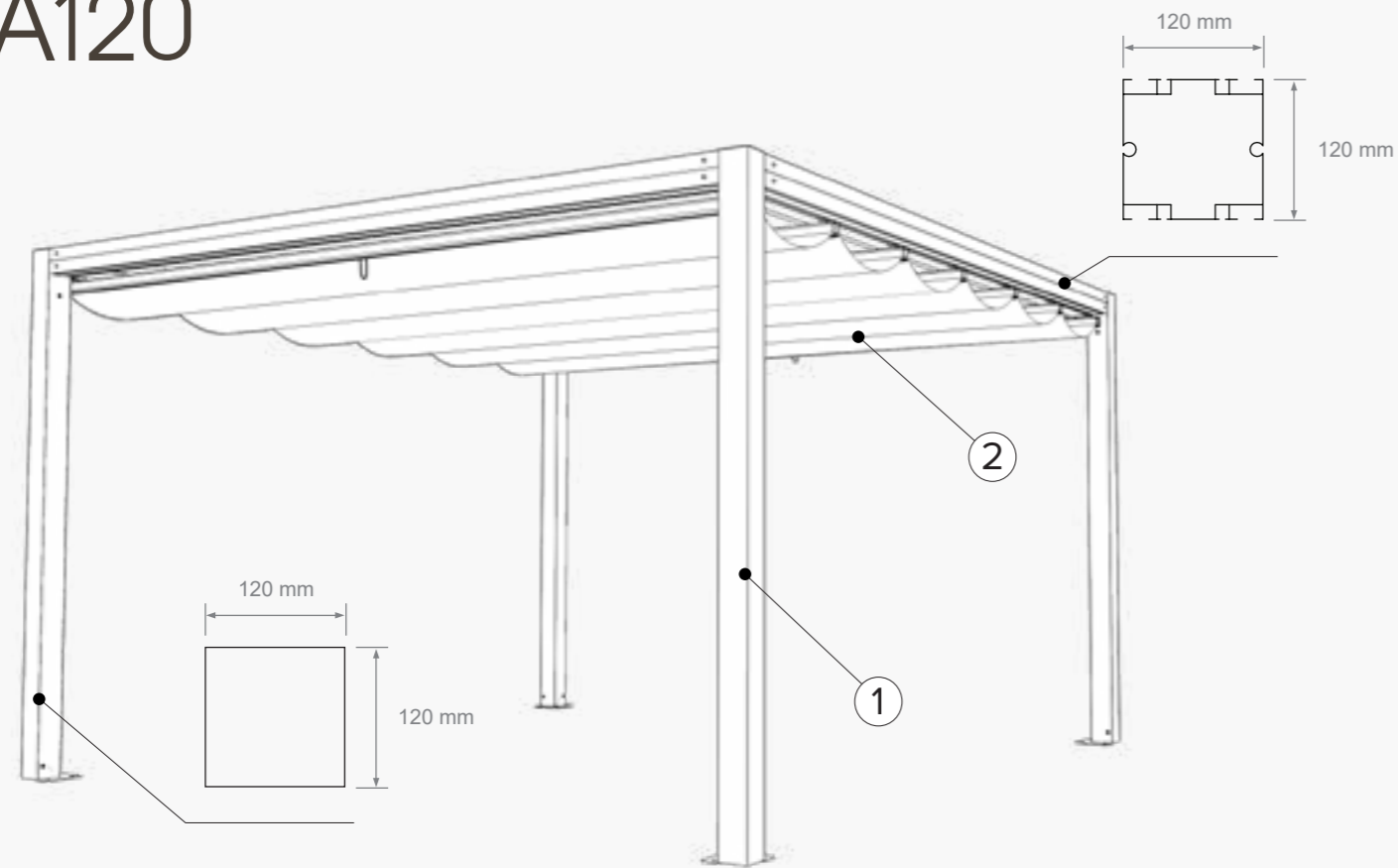

1 STANDARD COLOUR OF THE ALUMINIUM FRAME

IT - Colore standard della struttura in alluminio
 FR - Couleur standard de la structure en aluminium
 DE - Standardfarbe der Struktur in Aluminium
 ES - Color estándar de la estructura de aluminio

- | | |
|-----------------------------------|----------------------------------|
| ○ White
Matt-Rough Finish | ● Dove-Grey
Matt-Rough Finish |
| ● Dark-Brown
Matt-Rough Finish | ● Special
Grey |

2 STANDARD COLOUR OF THE PVC COVER

IT - Colore standard del telo di copertura in PVC
 FR - Couleur standard de la toile de couverture en PVC
 DE - Standardfarbe der PVC-Abdeckung
 ES - Color estándar de la cobertura en lona de PVC

- | | |
|---------|-------------|
| ○ White | ● Champagne |
| ● Grey | ● Dove-Grey |



3 STANDARD COLOUR OF THE CAPS

IT - Colore standard dei tappi
 FR - Couleur standard des bouchons
 DE - Standardfarbe der Abdeckungen
 ES - Color estándar de tapones

- Black

MODULAR CONFIGURATION

IT - Configurazione modulare
 FR - Configuration modulaire
 DE - Modulare Konfiguration
 ES - Configuración modular



DESIGN OF THE ROOF

IT - Forma del telo
 FR - Dessin de la bâche
 DE - Art der Abdeckung
 ES - Diseño del techo

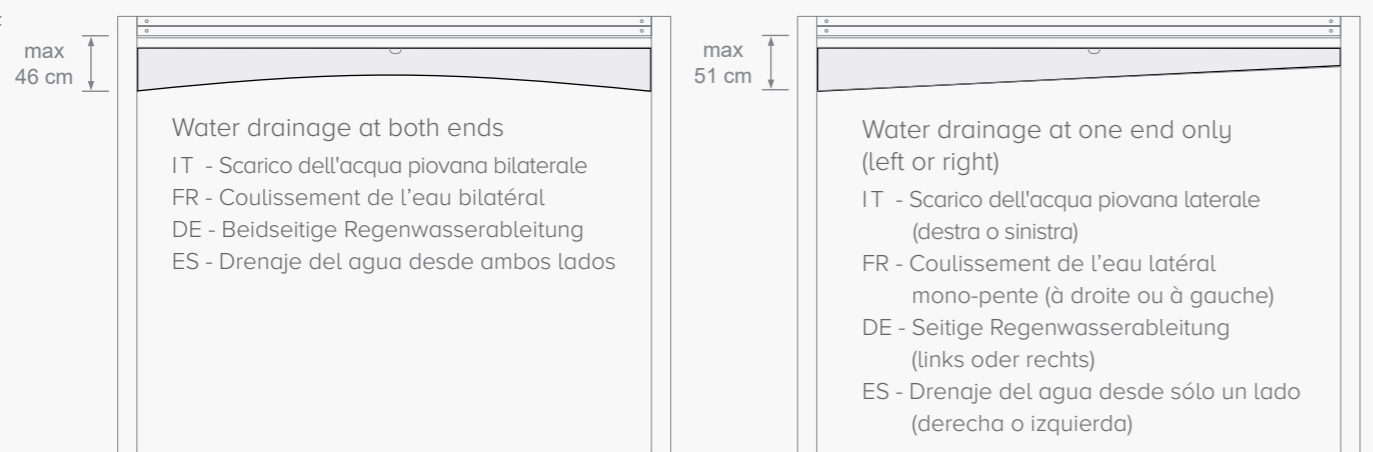

LEAN-TO VERSION

IT - Versione con struttura adossata a parete
 FR - Version avec structure adossée au mur
 DE - Wandbefestigung
 ES - Versión apoyada a la pared

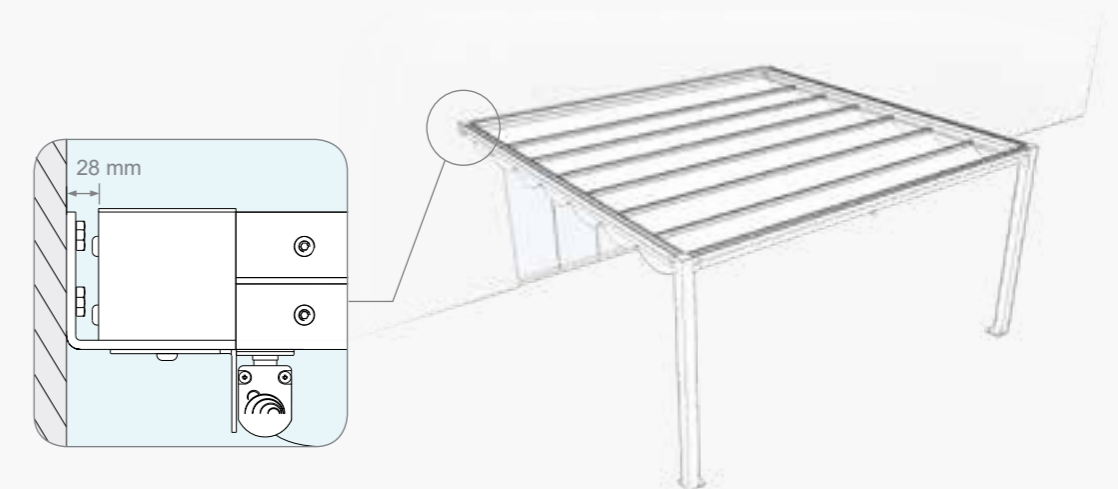

IT - DIMENSIONI DELLA STRUTTURA
 FR - DIMENSIONS DE LA STRUCTURE
 DE - ABMESSUNGEN DER STRUKTUR
 ES - DIMENSIONES DE LA ESTRUCTURA

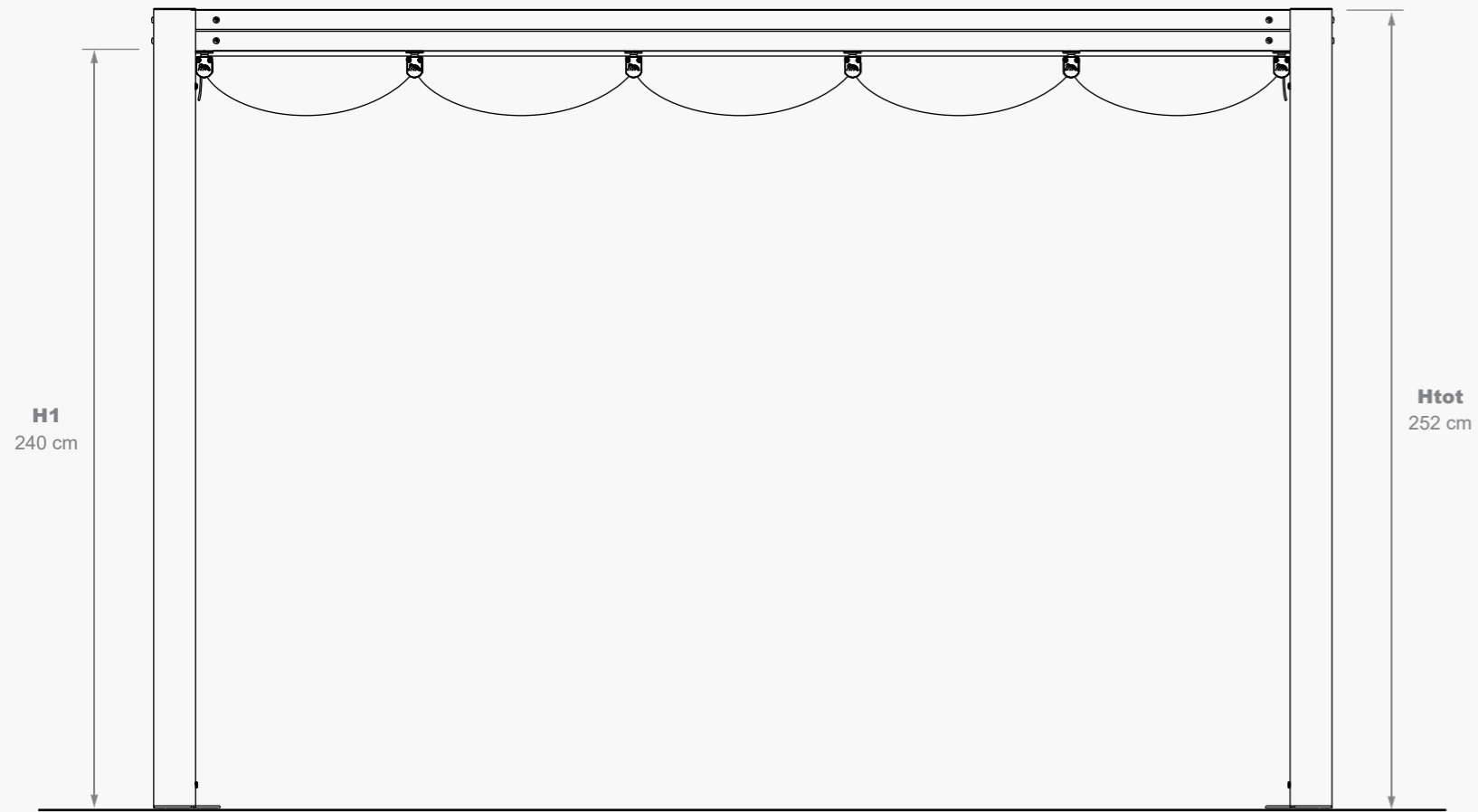

MAX DIMENSIONS					
FREE STANDING STRUCTURE	WALL-MOUNTED STRUCTURE		A (cm)	B (cm)	AREA (m ²)
			300	300	9
			400	400	16
			500	500	25
			300	400	12
			300	500	15
			400	500	20
			400	300	12
			500	300	15
			500	400	20

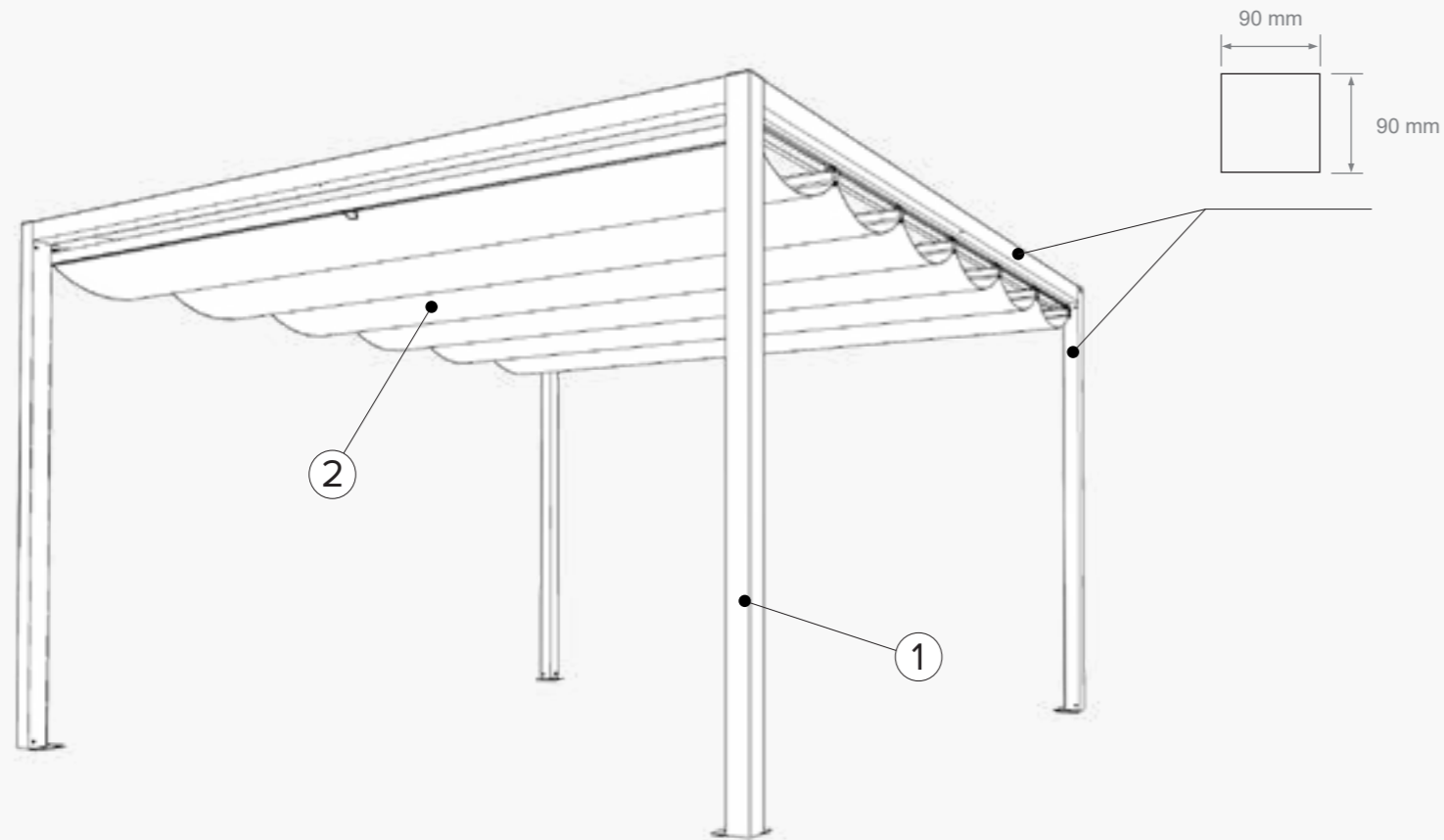

1 STANDARD COLOUR OF THE ALUMINIUM FRAME

IT - Colore standard della struttura in alluminio
 FR - Couleur standard de la structure en aluminium
 DE - Standardfarbe der Struktur in Aluminium
 ES - Color estándar de la estructura de aluminio

- White
- Matt-Rough Finish
- Dark-Brown
- Matt-Rough Finish
- Dove-Grey
- Matt-Rough Finish
- Special
- Grey

2 STANDARD COLOUR OF THE PVC COVER

IT - Colore standard del telo di copertura in PVC
 FR - Couleur standard de la toile de couverture en PVC
 DE - Standardfarbe der PVC-Abdeckung
 ES - Color estándar de la cobertura en lona de PVC

- White
- Grey
- Champagne
- Dove-Grey

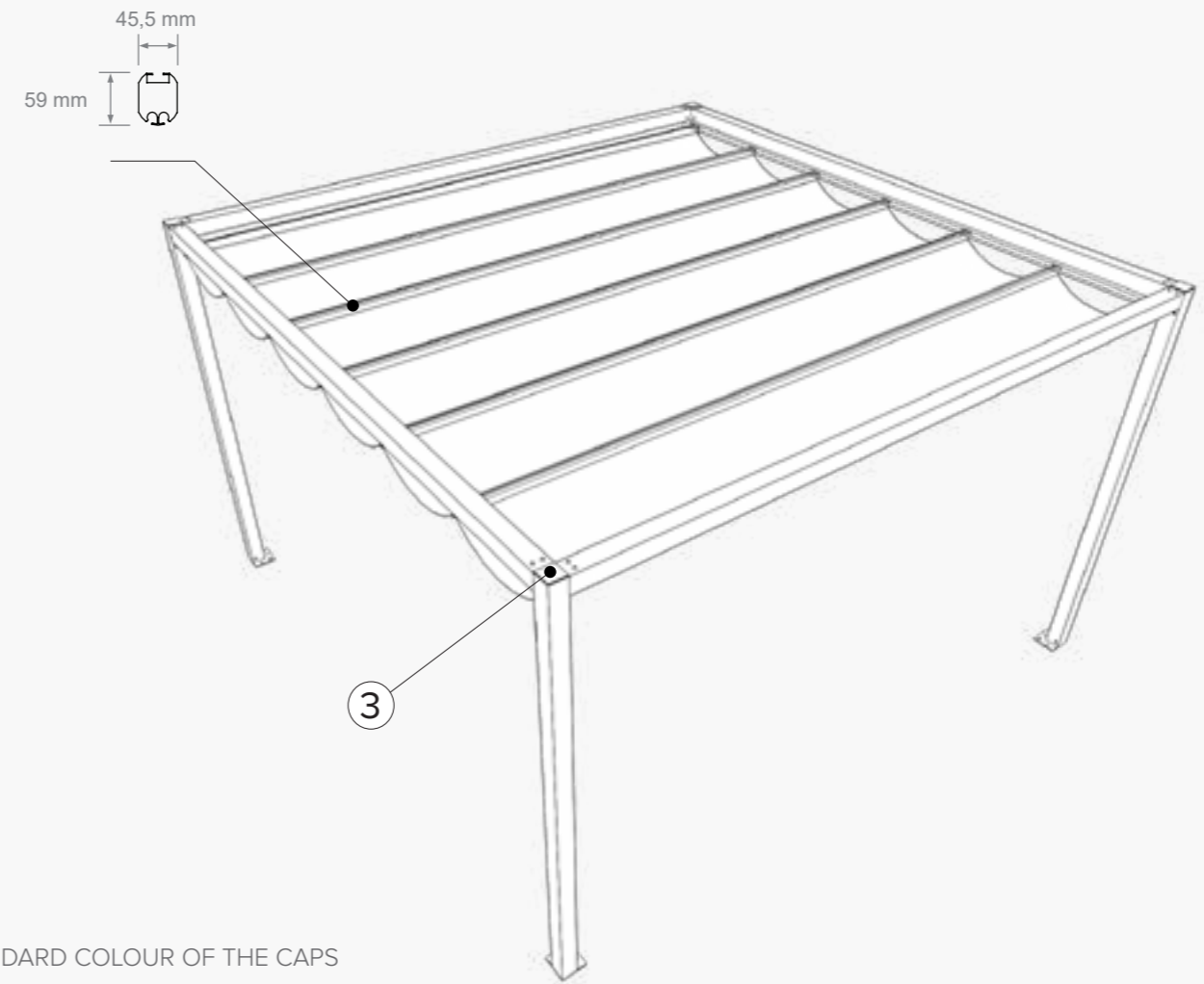

3 STANDARD COLOUR OF THE CAPS

IT - Colore standard dei tappi
 FR - Couleur standard des bouchons
 DE - Standardfarbe der Abdeckungen
 ES - Color estándar de tapones

- Black

DESIGN OF THE ROOF

IT - Forma del telo
 FR - Dessin de la bâche
 DE - Art der Abdeckung
 ES - Diseño del techo

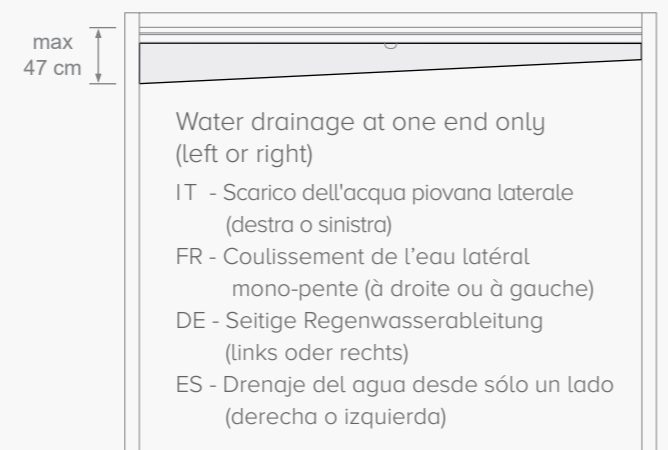
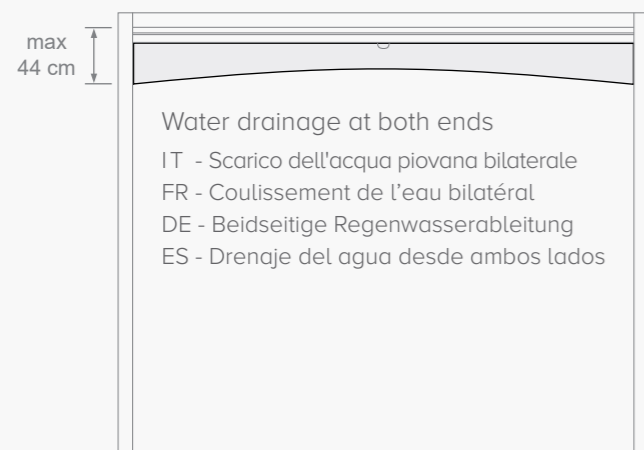

LEAN-TO VERSION

IT - Versione con struttura adossata a parete
 FR - Version avec structure adossée au mur
 DE - Wandbefestigung
 ES - Versión apoyada a la pared

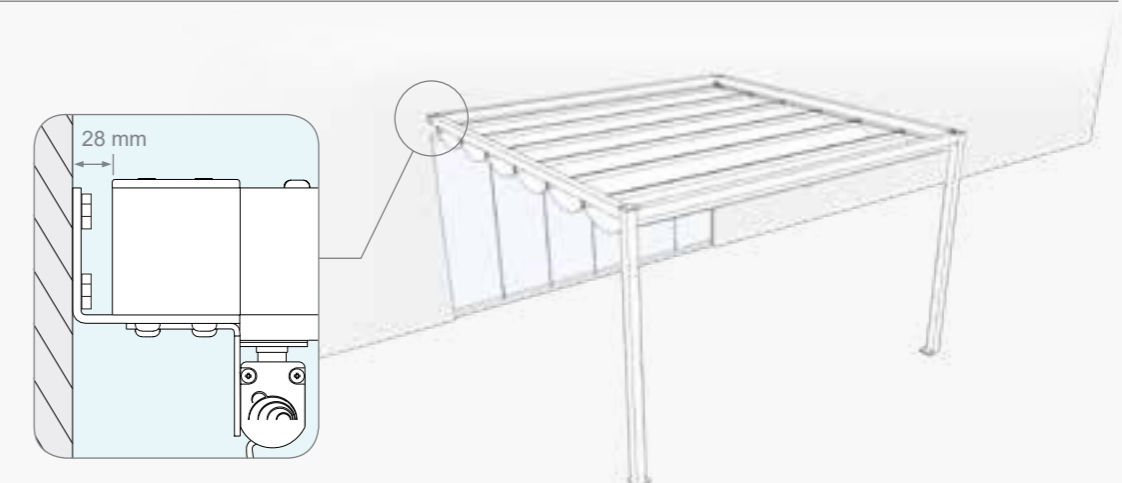

IT - DIMENSIONI DELLA STRUTTURA
 FR - DIMENSIONS DE LA STRUCTURE
 DE - ABMESSUNGEN DER STRUKTUR
 ES - DIMENSIONES DE LA ESTRUCTURA

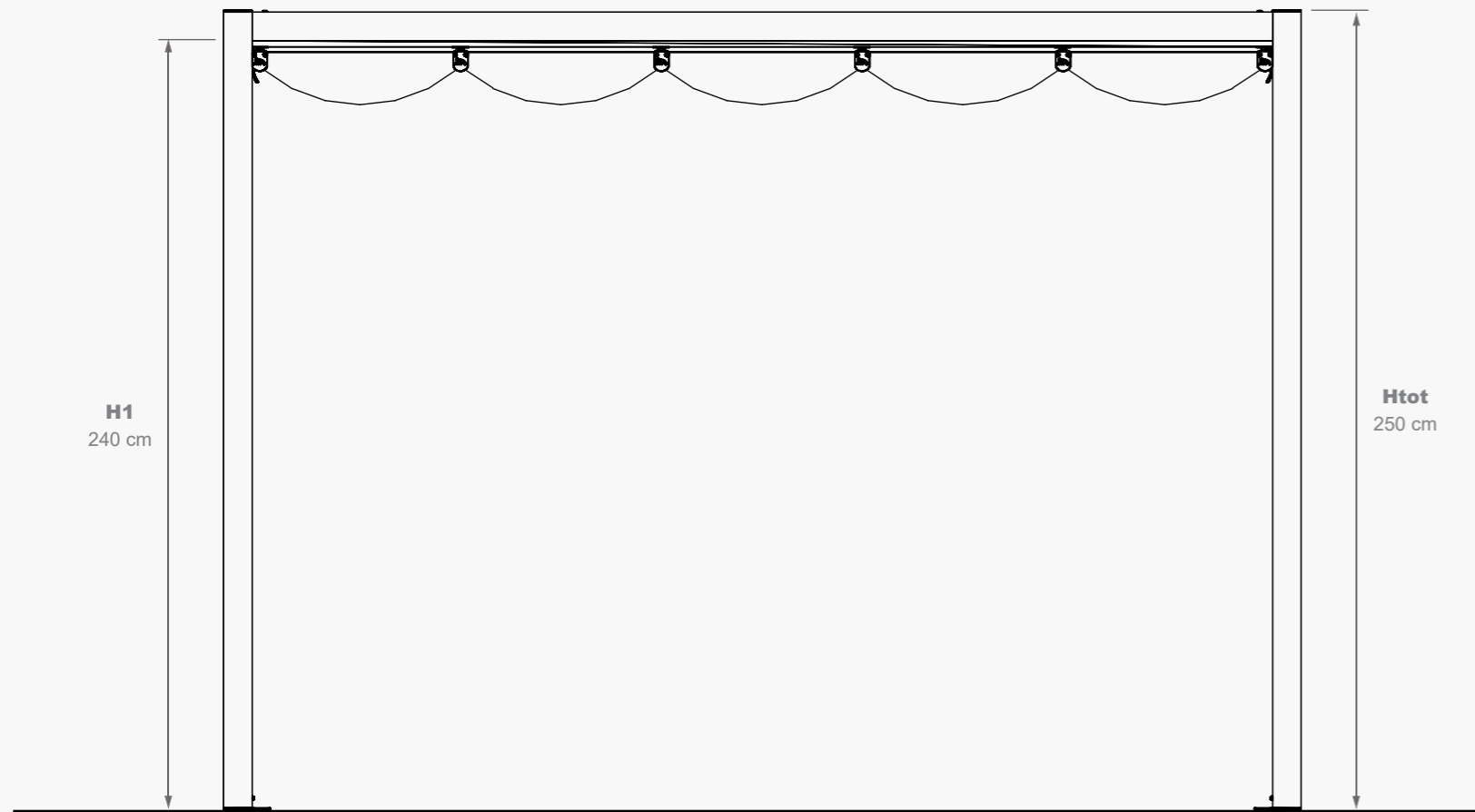

MAX DIMENSIONS					
FREE STANDING STRUCTURE	WALL-MOUNTED STRUCTURE		A (cm)	B (cm)	AREA (m ²)
			300	300	9
			400	400	16
			300	400	12
			400	300	12

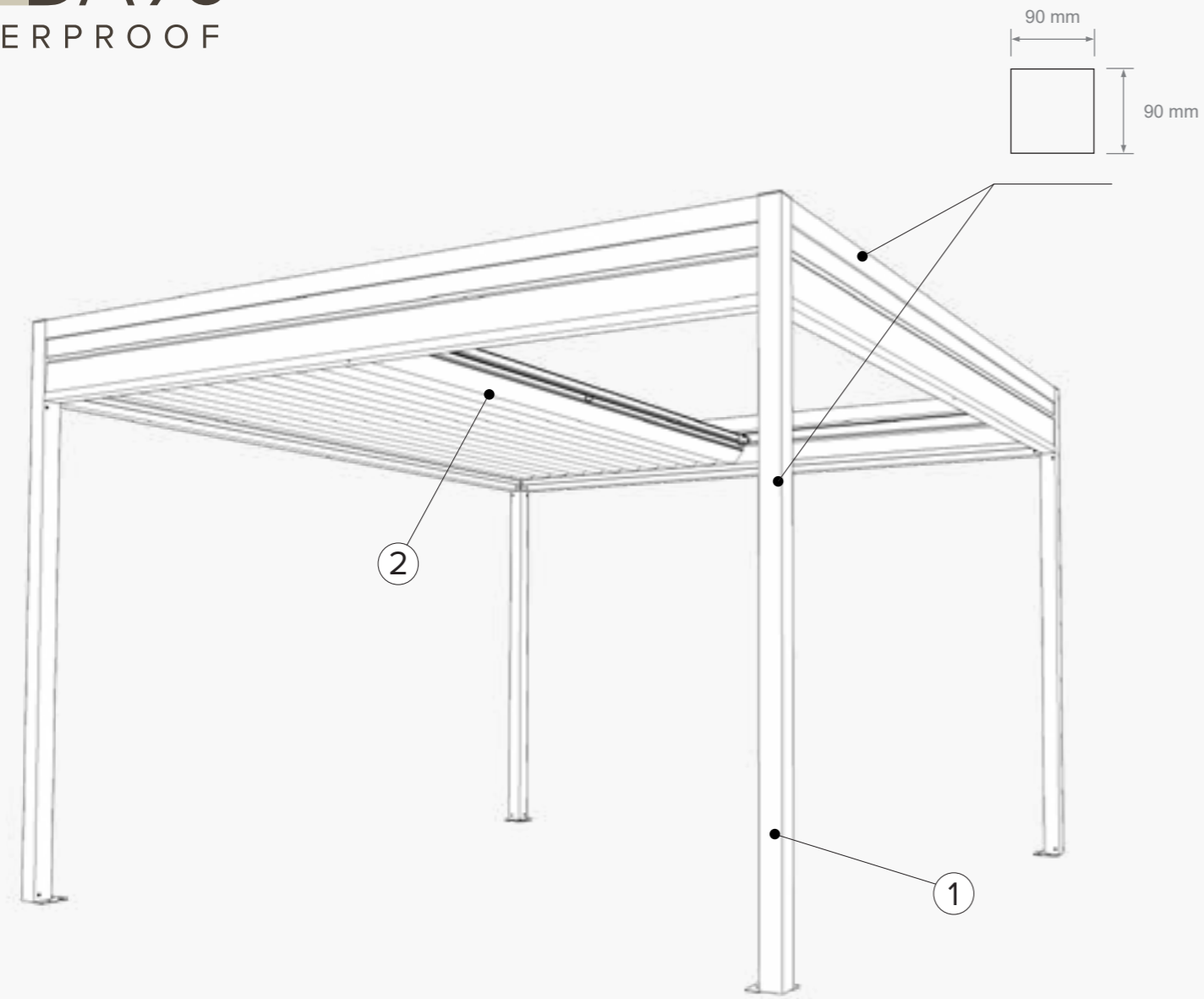

1 STANDARD COLOUR OF THE ALUMINIUM FRAME

IT - Colore standard della struttura in alluminio
FR - Couleur standard de la structure en aluminium
DE - Standardfarbe der Struktur in Aluminium
ES - Color estándar de la estructura de aluminio

- | | |
|-----------------------------------|----------------------------------|
| ○ White
Matt-Rough Finish | ● Dove-Grey
Matt-Rough Finish |
| ● Dark-Brown
Matt-Rough Finish | ● Special
Grey |

2 STANDARD COLOUR OF THE PVC COVER

IT - Colore standard del telo di copertura in PVC
FR - Couleur standard de la toile de couverture en PVC
DE - Standardfarbe der PVC-Abdeckung
ES - Color estándar de la cobertura en lona de PVC

- | | |
|---------|-------------|
| ○ White | ● Champagne |
| ● Grey | ● Dove-Grey |

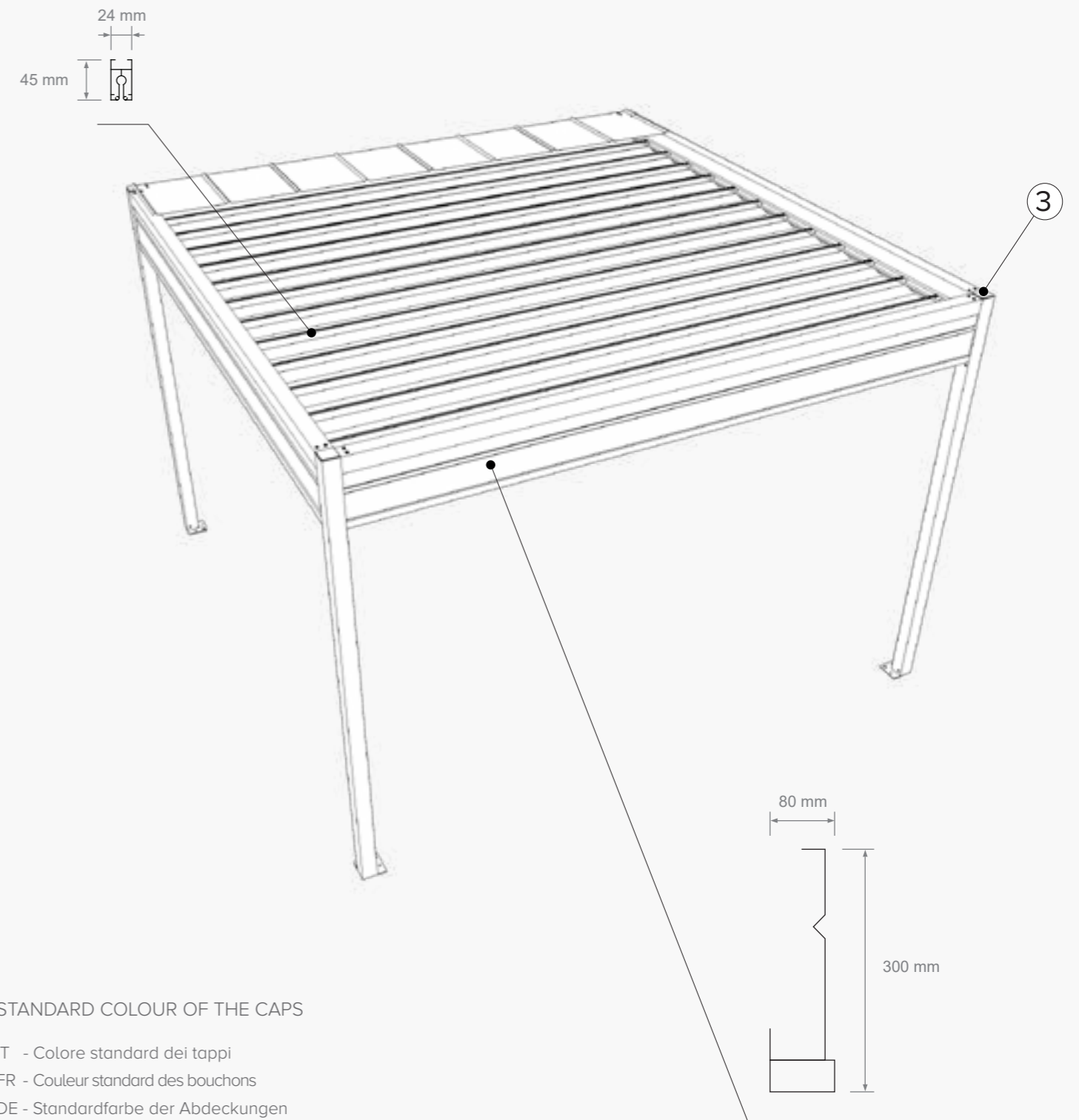

3 STANDARD COLOUR OF THE CAPS

IT - Colore standard dei tappi
FR - Couleur standard des bouchons
DE - Standardfarbe der Abdeckungen
ES - Color estándar de tapones

- Black

STRUCTURE DIMENSIONS

IT - DIMENSIONI DELLA STRUTTURA
FR - DIMENSIONS DE LA STRUCTURE
DE - ABMESSUNGEN DER STRUKTUR
ES - DIMENSIONES DE LA ESTRUCTURA



MAX DIMENSIONS			
FREE STANDING STRUCTURE	A (cm)	B (cm)	AREA (m ²)
	300	300	9
	400	400	16
	300	400	12
	400	300	12



www.giuliobarbieri.it

