



PENSILSOLE



FOOD CENTER

ALUMINIUM CARPORTS

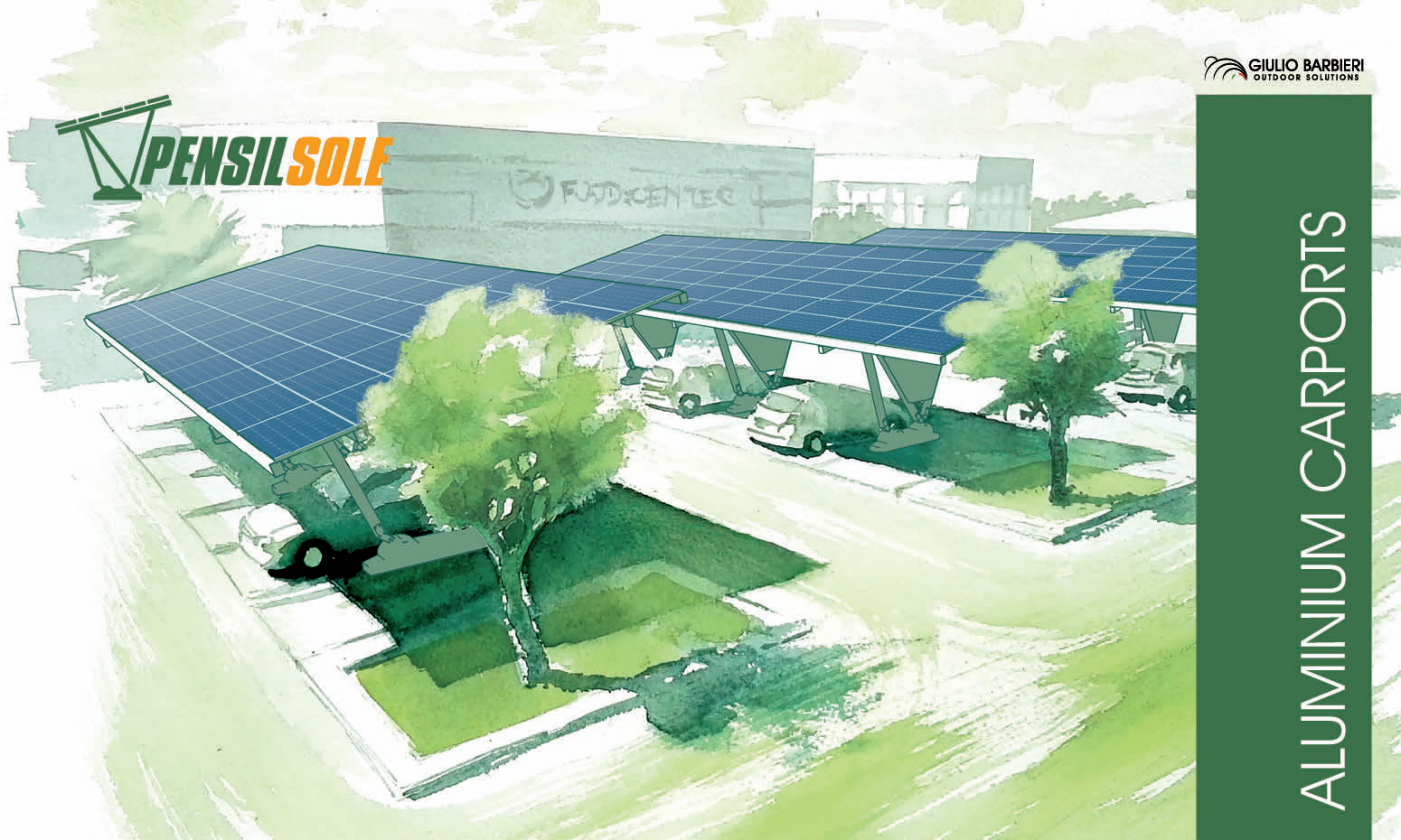



DISCOVER THE BENEFITS OF A COVERED PARKING SPACE

- SCOPRI I VANTAGGI DI UN POSTO AUTO COPERTO
- DÉCOUVREZ LES AVANTAGES D'UNE PLACE DE PARKING COUVERTE
- ENTDECKEN SIE DIE VORTEILE EINES ÜBERDACHTEN PARKPLATZES
- DESCUBRE LAS VENTAJAS DE UNA PLAZA DE APARCAMIENTO CUBIERTA



SAVE BY PROTECTING YOUR VEHICLE

- RISPARMIA PROTEGGENDO IL TUO VEICOLO
- ÉCONOMISEZ EN PROTÉGEANT VOTRE VÉHICULE
- SPAREN SIE GELD, INDEM SIE IHR FAHRZEUG SCHÜTZEN
- AHORRA PROTEGIENDO TU VEHÍCULO



GENERATE GREEN ENERGY WITH THE INSTALLATION OF SOLAR PANELS

- CREA ENERGIA PULITA CON L'INSTALLAZIONE DI MODULI FOTOVOLTAICI
- CRÉEZ DE L'ÉNERGIE AVEC L'INSTALLATION DE MODULES PHOTOVOLTAÏQUES
- ERZEUGEN SIE ENERGIE DURCH DIE INSTALLATION VON PHOTOVOLTAÏKMODULEN
- CREA ENERGÍA CON LA INSTALACIÓN DE MÓDULOS FOTOVOLTAICOS



PREVENT ANY DAMAGE TO YOUR ROOF BY CHOOSING A SOLAR CARPORT REQUIRING LOW MAINTENANCE.

- EVITA DI DANNEGGIARE IL TETTO DELLA TUA ABITAZIONE SCEGLIENDO UN IMPIANTO FOTOVOLTAICO SU PENSILINA, CON MINORI COSTI DI MANUTENZIONE
- ÉVITEZ D'ENDOMMAGER LE TOIT DE VOTRE MAISON EN CHOISSANT UN SYSTÈME PHOTOVOLTAÏQUE SUR UN ABRI, AVEC DES COÛTS DE MAINTENANCE INFÉRIEURS
- VERMEIDEN SIE ES, DAS DACH IHRES HAUSES ZU BESCHÄDIGEN, INDEM SIE EINE PHOTOVOLTAIKANLAGE AUF DEM CARPORT MIT GERINGEREN WARTUNGSKOSTEN WÄHLEN.
- EVITA DAÑAR EL TEJADO DE TU VIVIENDA ELIGIENDO UNA INSTALACIÓN FOTOVOLTAICA CON MARQUESINA, CON MENORES COSTES DE MANTENIMIENTO





WHY SHOULD YOU CHOOSE OUR CARPORTS?

- PERCHÈ SCEGLIERE LE NOSTRE PENSILINE?
- POURQUOI CHOISIR NOS ABRIS ?
- WARUM SIE UNSERE CARPORTS WÄHLEN SOLLTEN?
- ¿POR QUÉ ELEGIR NUESTRAS MARQUESINAS?



THE STRUCTURE IS MADE OUT OF ALUMINIUM PROFILES AND POWDER COATED STEEL COMPONENTS CATAPHORESIS TREATED. NO ORDINARY MAINTENANCE IS NEEDED.

- La struttura è costituita da profili in alluminio e componenti in acciaio cataforesato e verniciato, quindi non necessitano di interventi di ordinaria manutenzione.
- La structure est réalisée avec des composants en acier laqué et soumis à traitement de cathorèse (anticorrosion) qui ne nécessitent d'aucun entretien extraordinaire au long terme.
- Die Struktur besteht aus Aluminiumprofilen und Stahlteilen, die der Kataphorese und Lackierung unterzogen werden, so dass keine besondere Wartung erforderlich ist.
- La estructura cuenta con perfiles de aluminio y componentes de acero sometido a cataforesis y esmaltado, por lo tanto, no requiere tareas de mantenimiento extraordinario.



QUICK INSTALLATION TIMES.

The rapid assembly reduces the installation cost and avoids any interruption to the regular activities while work is carried out.

- I tempi rapidi di montaggio riducono i costi d'installazione ed evitano di creare disagi ostacolando le attività che normalmente si svolgono in prossimità della pensilina.
- Les temps de montage rapides réduisent les coûts d'installation et évitent de créer des inconvénients en évitant d'entraver les activités qui se déroulent à proximité du lieu d'installation.
- Die schnellen Montagezeiten reduzieren die Installationskosten und vermeiden Unannehmlichkeiten durch Behinderung der Tätigkeiten, die normalerweise in der Nähe des Carports stattfinden.
- La rapidez de montaje reduce los costes de instalación y evita crear molestias obstaculizando las actividades que habitualmente se llevan a cabo cerca de la marquesina.



ALL GIULIO BARBIERI CARPORTS ARE DESIGNED TO BE FITTED WITH ANY KIND AND MODEL OF SOLAR PANEL.

- Tutte le pensiline Giulio Barbieri sono predisposte per l'installazione di pannelli fotovoltaici di qualsiasi tipo e marca.
- Tous les abris Giulio Barbieri sont prédisposés pour l'installation de tous sortes de panneaux photovoltaïques.
- Alle Giulio Barbieri Carports sind für die Installation von Photovoltaikmodulen jeder Art und Marke konzipiert.
- Todas las marquesinas Giulio Barbieri se preparan para instalar paneles fotovoltaicos de cualquier tipo y marca.



STRUCTURES ARE MODULAR AND UPON REQUEST CAN BE FITTED WITH AN EFFICIENT GUTTERING SYSTEM.

- Le strutture sono modulari e dotate di un efficace sistema di grondaie e pluviali.
- Les structures sont modulaires et munies, sur demande, d'un système efficace de gouttières.
- Die Strukturen sind modular aufgebaut und auf Wunsch mit einem wirksamen Dachrinnen- und Fallrohr-System ausgestattet.
- Las estructuras son modulares y, previa solicitud, cuentan con un sistema eficaz de canalones y accesorios de evacuación de agua.



CARPORTS ARE GENERALLY SUPPLIED WITH CONCRETE BALLASTS. ADVANTAGES:

- 1) No expensive foundations are required meaning little or no spoil.
- 2) All carports on ballasts are meant as temporary structures, however to find out if your project will need planning permission contact your local authority.
- 3) If needed the structure can be easily relocated to another place.

Upon request a steel plates version is available to be bolted down onto existing or purpose built foundations.

- LE PENSILINE SONO DOTATE DI BASI DI APPOGGIO IN CEMENTO ARMATO. VANTAGGI: 1) Non è necessario predisporre onerosi e costose fondazioni, evitando di deturpare il suolo; 2) Il carport con basi in cemento armato è classificabile come struttura temporanea amovibile e nella maggioranza dei casi non è necessario effettuare alcuna pratica presso il Genio Civile. Consultare gli uffici tecnici del Comune di riferimento; 3) In caso di necessità, la struttura può essere facilmente spostata in un altro luogo d'installazione. Su richiesta è disponibile anche la versione con piastre in acciaio da fissare ad una fondazione esistente o appositamente predisposta sul luogo d'installazione.
- LES ABRIS SONT MUNIS DE BASES D'APPUI EN BÉTON ARMÉ. Avantages : 1) Il n'est pas nécessaire de préparer des fondations onéreuses, en évitant de dégrader le sol; 2) Tous les abris voiture munis de bases d'appui en béton armé sont conçus comme des structures temporaires, cependant, pour savoir si votre projet nécessite un permis de construire, contactez votre autorité locale; 3) Si nécessaire, la structure peut être facilement déplacée vers un autre lieu d'installation. Sur demande, la version avec des plaques en acier à fixer à une fondation existante ou spécialement préparée est également disponible.
- DIE CARPORTS SIND MIT STAHLBETONSTÜTZEN AUSGESTATTET. VORTEILE: 1) Es müssen keine kostspieligen Fundamente vorgesehen werden, wodurch eine Beschädigung des Bodens vermieden wird.; 2) Alle Carports auf Ballasten sind als temporäre Bauten gedacht, aber um herauszufinden, ob Ihr Projekt eine Baugenehmigung benötigt, wenden Sie sich an Ihre Gemeinde. 3) Bei Bedarf kann die Struktur leicht an einen anderen Aufstellort verlegt werden. Auf Anfrage ist auch die Ausführung mit Stahlplatten zur Befestigung auf einem vorhandenen oder speziell vorbereiteten Fundament erhältlich.
- LAS MARQUESINAS LLEVAN BASES DE APOYO DE HORMIGÓN ARMADO. VENTAJAS: 1) No necesitan cimentaciones costosas, evitando degradar el suelo; 2) Todas las marquesinas con bases de apoyo de hormigón puede ser una estructura temporal. Para averiguar si su proyecto necesite permiso consulte al ayuntamiento; 3) En caso de necesidad, la estructura puede ser fácilmente trasladada a otro lugar de instalación. Bajo pedido, también existe la versión con placas de acero para fijar en una cimentación existente o expresamente preparada.



COLOURS AND SIZES OF THE STRUCTURE ARE CUSTOMISABLE. RIGID BRANDED PANELS WITH LOGO AND GRAPHICS CAN BE INSTALLED.

- Le strutture sono personalizzabili nelle dimensioni e nelle finiture, inoltre è possibile installare pannelli con loghi e grafiche pubblicitarie.
- Les dimensions et la couleur des structures sont personnalisables et il est également possible d'installer des panneaux rigides avec des logos et des personnalisations graphiques publicitaires.
- Die Strukturen sind in Größe und Farbe anpassbar und Sie können auch starre Paneele mit Logos und Werbegrafiken installieren.
- Las estructuras se pueden personalizar en tamaños y colores, además se pueden instalar paneles rígidos con logotipos e impresión gráfica publicitaria.



THE ALUMINIUM PROFILES MAY REPRESENT A SOURCE OF PROFIT IN THE RECYCLING PHASE.

- In fase di riciclo i profilati in alluminio della struttura rappresentano una fonte di profitto.
- En phase de recyclage, les profilés de la structure représentent une source de profit.
- Die Strukturprofile aus Aluminium sind eine Gewinnquelle für das Recycling.
- Durante la fase de reciclaje los perfiles de la estructura representan una fuente de beneficio.



DO YOU HAVE A BUSINESS? SHOW THE WORLD YOUR 'GREEN SPIRIT'!

CARPORTS CAN BE INTEGRATED WITH OUR EV CHARGING UNITS: BRANDING WITH YOUR COMPANY LOGO AND COLOURS IS AVAILABLE!

- **HAI UN'ATTIVITÀ? MOSTRA AL MONDO LA TUA 'ANIMA GREEN'!**
Le nostre pensiline possono essere integrate con barre di ricarica per veicoli elettrici personalizzabili con i colori e il logo della tua azienda! Hai un'attività? Mostra al mondo la tua anima green installando una stazione di ricarica per veicoli elettrici personalizzata con il tuo logo!
- **AVEZ-VOUS UNE ENTREPRISE ? MONTREZ VOTRE « ÂME VERTE » AU MONDE !**
Les abris peuvent être intégrés avec nos barres de recharge pour véhicules électriques personnalisables avec les couleurs et le logo de votre entreprise !
- **HABEN SIE EINE AKTIVITÄT? ZEIGEN SIE DER WELT IHRE GRÜNE SEELE!**
Die Carports können mit unseren Elektrofahrzeug-Ladebalken integriert werden, die mit den Farben und dem Logo Ihres Unternehmens individuell gestaltet werden können!
- **¿TIENES UNA TIENDA? ¡MUÉSTRALE AL MUNDO TU 'ALMA ECOLÓGICA'!**
¡Las marquesinas pueden completarse con nuestras barras de recarga para vehículos eléctricos personalizables con los colores y el logotipo de tu empresa!

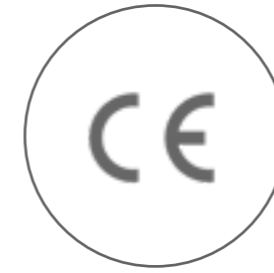

WARRANTY AND QUALITY

- All of our structures' components are CE certified.
- Flame retardancy certificates are provided for all kinds of PVC fabrics.
- Structures are checked for load capacity in accordance with EN 13782, DM 17th January 2018 Technical Standards for Constructions and UNI EN 1991.
- Pullout capacity test of the stakes is available upon request.
- Products have a legal warranty of 10 years.
- Installations are carried out by our dedicated teams. If the set-up is performed by the customer, one of our site supervisors can monitor the process.

QUALITÀ & GARANZIA

- I singoli componenti delle strutture sono certificati CE.
- Vengono forniti i certificati di ignifugazione per ogni tipologia di telo utilizzato.
- Le strutture sono verificate ai carichi previsti dalle normative vigenti EN 13782, DM 17 Gennaio 2018 Norme Tecniche per le Costruzioni NTC e UNI EN 1991.
- Servizio di prova estrazione picchetti a richiesta.
- Le installazioni vengono eseguite da nostre squadre specializzate. In caso di installazioni in via autonoma, su richiesta possiamo mettere a disposizione un nostro tecnico per la direzione del cantiere.
- Le strutture sono garantite 10 anni.

GARANTIE ET QUALITÉ

- Chaque composant des structures est certifié CE.
- Les certificats d'ignifugation sont fournis pour tout type de toile utilisée.
- Les structures sont vérifiées avec les charges prévues par les réglementations en vigueur EN 13782, DM 17 Janvier 2018 Normes Techniques pour les Constructions NTC et UNI EN 1991.
- service d'essai de résistance à l'extraction des piquets sur demande.
- Les installations sont effectuées par nos équipes spécialisées. En cas d'installations autonomes de la part du client, sur demande nous pouvons mettre à disposition l'un de nos techniciens pour la gestion du chantier.
- Les structures sont garanties 10 ans.

GARANTIE UND QUALITÄT

- Die einzelnen Komponenten der Struktur haben das CE-Zertifikat.
- Zertifikate der Schwerentflammbarkeit sind für jede Art von Tuch vorgesehen.
- Die Strukturen werden auf Lasten geprüft, wie durch die geltenden Normen EN 13782, DM 17 Januar 2018 Technische Normen für das Bauen NTC und UNI EN 1991 vorgesehen sind.
- Testservice zum Herausziehen von Pflöcken auf Anfrage.
- Die Installationen werden von unseren spezialisierten Teams durchgeführt. Bei autonom durchgeführten Installationen stellen wir auf Wunsch einen unserer Techniker für die Bauleitung zur Verfügung.
- Die Strukturen sind für 10 Jahre garantiert.

GARANTÍA Y CALIDAD

- Los componentes individuales de las estructuras están certificados CE.
- Se entregan los certificados de propiedad ignífuga para cada tipo de lona utilizada.
- Las estructuras se ensayan con las cargas previstas en las normativas vigentes EN 13782, DM 17 de enero de 2018 Normas técnicas para las construcciones NTC y UNI EN 1991.
- Servicio de prueba extracción piquetas bajo pedido.
- Las instalaciones las realizan nuestros equipos especializados. En caso de instalaciones de forma autónoma, previa solicitud, podemos poner a disposición un técnico nuestro para dirigir la obra.
- Las estructuras están garantizadas por 10 años.



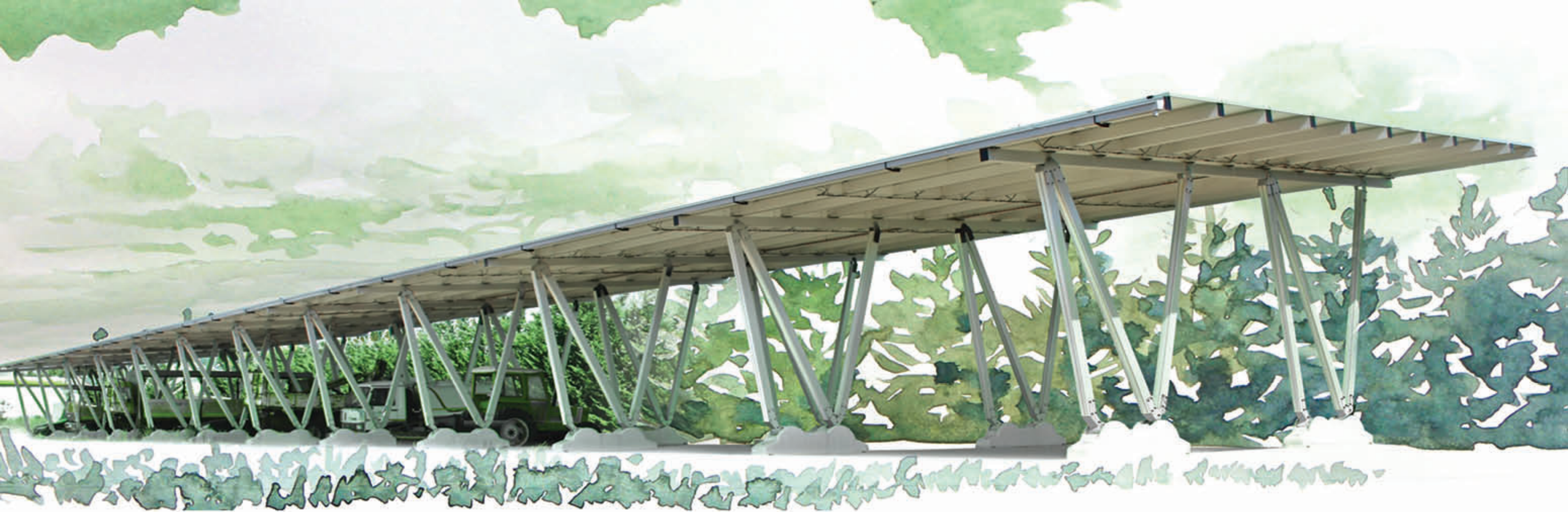

MIDDLE
PENSILSOLE



PENSILSOLE

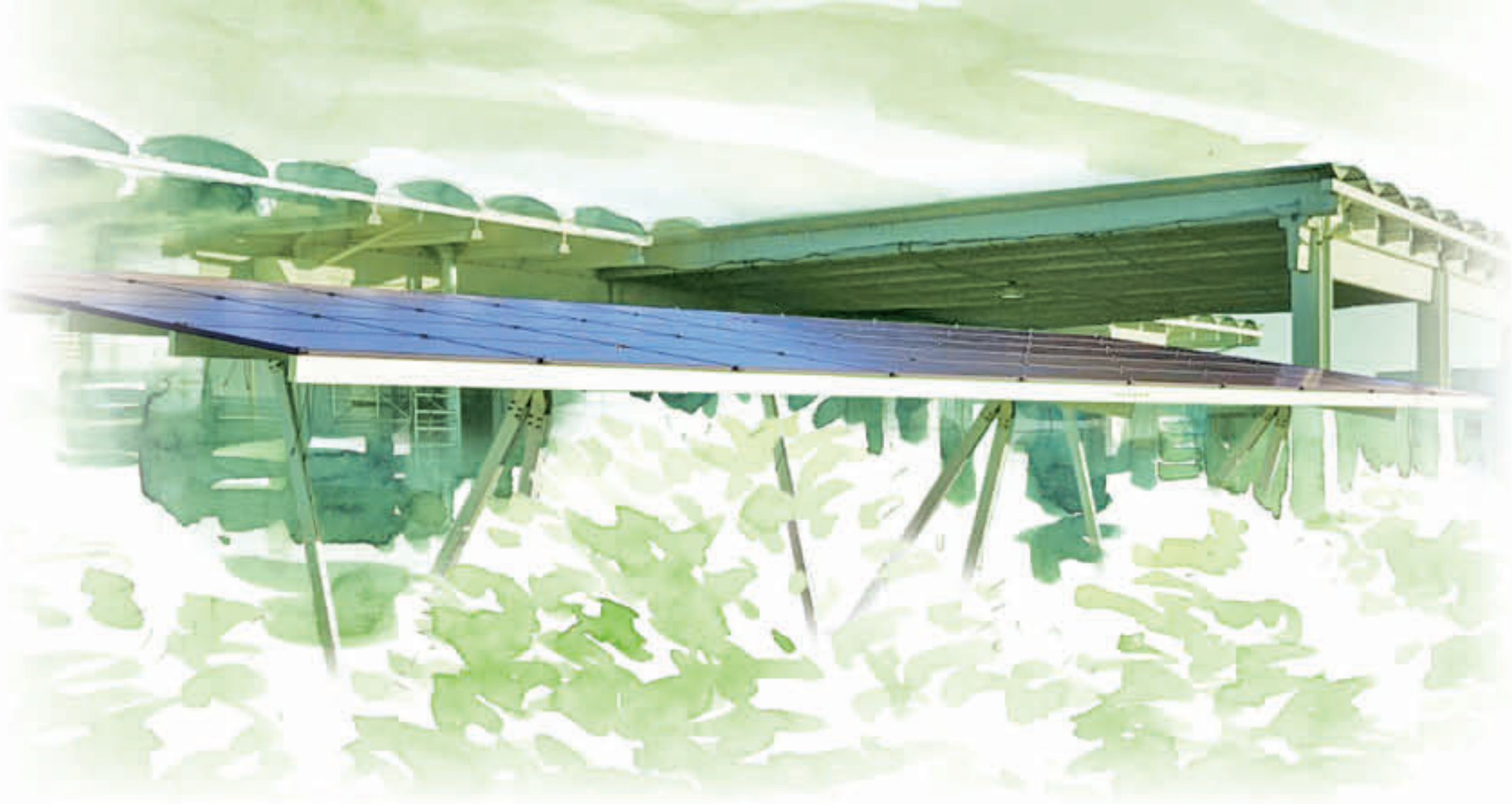







REFERENCES



Obernburg am Main,
German



Zwickau, German



Bad Schlema, German



Sweden



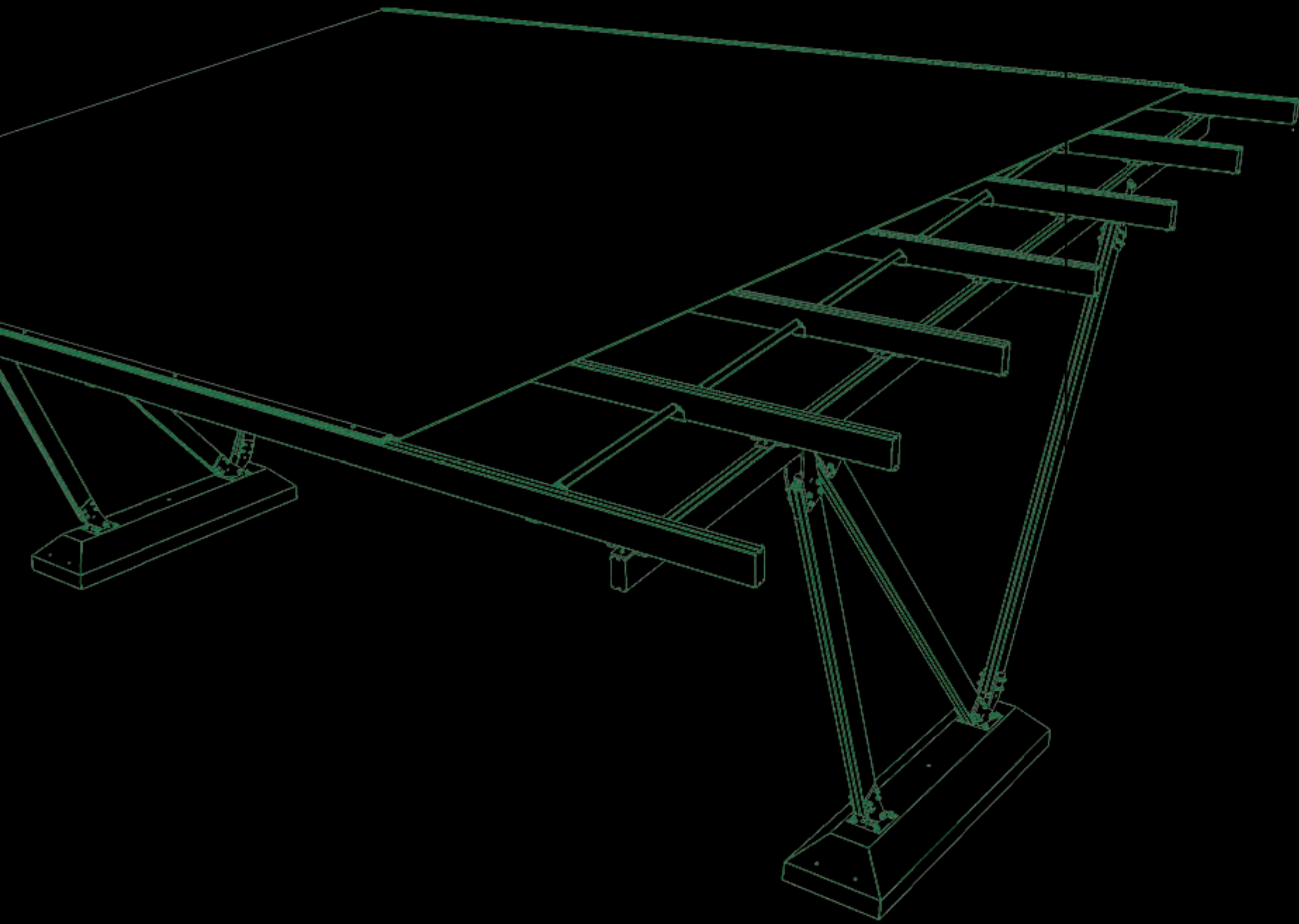

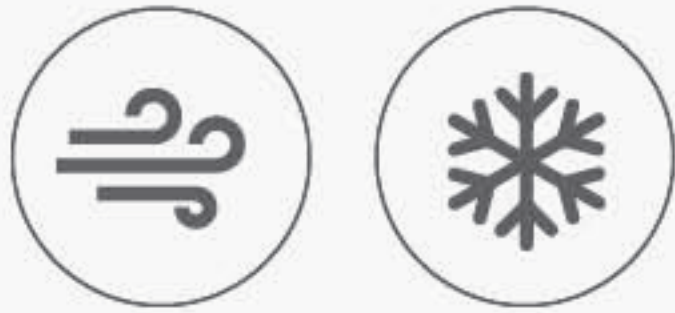

TECHNICAL
DRAWINGS







WIND AND SNOW LOADS

(the following loads are indicative only, for further info please contact the office)

IT - Carico di neve e vento (i dati riportati sono indicativi, per informazioni dettagliate rivolgersi agli uffici commerciali)
 FR - Charges neige et vent (les données présentées sont indicatives, pour d'infos plus détaillées, contacter le département commercial)
 DE - Schnee u. Windlasten (die folgenden Angaben sind unverbindlich. Für detaillierte Informationen bitte nehmen Sie Kontakt mit uns auf)
 ES - Carga de nieve y viento (los siguientes datos son indicativos para obtener informaciones detalladas consulte nuestro departamento comercial)

RESISTANCE OF THE CARPORT TO THE WIND AND SNOW LOADS		
	Pensilauto middle/light Pensilsole middle	Pensilauto Pensilsole
		
Wind load	low wind load	high wind load
Snow load	low snow load	high snow load

FACTORS AFFECTING THE WIND LOAD	
Wind speed	
Location and altitude	
Terrain category	

FACTORS AFFECTING THE SNOW LOAD	
Location and altitude	

D.M. 17/01/2018; EN 1991-1-3

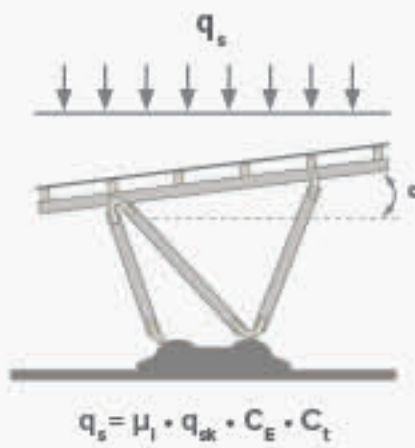

The snow load (q_s) is obtained from the ground snow load (q_{sk}) applied in a vertical direction on the horizontal projection of the inclined roof surface (shape coefficient μ_i). The snow load is also affected by the exposure (C_e) and temperature (C_t) of the roof.

IT - L'azione variabile della neve (q_s) si calcola attraverso il carico neve al suolo (q_{sk}) applicato in direzione verticale rispetto alla proiezione orizzontale della superficie della copertura inclinata (coefficiente di forma μ_i). L'azione della neve varia in base all'esposizione (C_e) ed alla temperatura (C_t) della copertura.

FR - L'action variable de la neige (q_s) est calculée à travers de la charge neige sur le sol (q_{sk}) appliquée en direction vertical par rapport à la projection horizontal de la surface de la couverture inclinée (coefficient de forme μ_i). L'action de la neige varie selon l'exposition (C_e) et la température (C_t) de la couverture.

DE - Die variable Schneewirkung (q_s) wird durch die in vertikaler Richtung aufgebraachte Schneelast (q_{sk}) in Bezug auf die horizontale Projektion der geneigten Dachfläche (μ_i shape coefficient) berechnet. Die Schneewirkung hängt von der Exposition (C_e) und der Temperatur (C_t) des Daches ab.

ES - La acción variable de la nieve (q_s) se obtiene de la carga de nieve sobre el suelo (q_{sk}) aplicada en una dirección vertical con respecto a la proyección horizontal de la superficie inclinada del techo (coeficiente de forma μ_i). La acción de la nieve también varía según la exposición (C_e) y la temperatura (C_t) del techo.

D.M. 17/01/2018; EN 1991-1-4

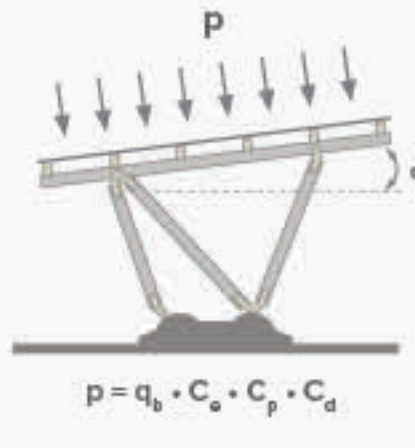

The wind load (p) is given by the kinetic pressure of reference (q_b) which acts perpendicularly on the roof and varies according to the exposure (C_s), shape and orientation (pressure coefficient C_p) and according to the dynamic response (dynamic coefficient C_d) of the frame.

IT - L'azione variabile del vento (p) è data dalla pressione cinetica di riferimento (q_b) che agisce perpendicolarmente sulla superficie della copertura e varia in base all'esposizione (C_s), alla forma e orientamento (coefficiente di pressione C_p) e alla risposta dinamica (coefficiente dinamico C_d) della stessa.

FR - L'action variable du vent (p) est donnée par la pression dynamique de référence (q_b) qui agit perpendiculairement sur la surface de la couverture et varie selon l'exposition (C_s), la forme et l'orientation (coefficient de pression C_p) et la réponse dynamique (coefficient dynamique C_d) de la couverture.

DE - Die variable Wirkung des Windes (p) wird durch den kinetischen Bezugsdruck (q_b) gegeben, der senkrecht auf die Dachoberfläche wirkt und je nach Exposition (C_s), Form und Ausrichtung (Druckkoeffizient C_p) und seinem dynamischen Verhalten (dynamischer Koeffizient C_d) variiert.

ES - La acción variable del viento (p) está dada por la presión cinética de referencia (q_b) que actúa perpendicolarmente en la superficie del techo y varía según la exposición (C_s), la forma y la orientación (coeficiente de presión C_p) y según la respuesta dinámica (coeficiente dinámico C_d) de la misma estructura.



THE STRUCTURES ARE CUSTOMIZABLE IN THE SIZES, COLOURS AND FINISHES, AND CAN ALSO BE EQUIPPED WITH ADVERTISING PANELS

- LE STRUTTURE SONO PERSONALIZZABILI NELLE DIMENSIONI, NEI COLORI E NELLE FINITURE, INOLTRE È POSSIBILE DOTARLE DI PANNELLI PUBBLICITARI
- LES STRUCTURES SONT PERSONNALISABLES DANS LES DIMENSIONS, LES COULEURS ET LES FINITIONS; EN PLUS IL EST POSSIBLE DE LES ÉQUIPER AVEC DE PANNEAUX PUBLICITAIRES
- DIE STRUKTUREN SIND IN GRÖSSE, FARBE UND AUSFÜHRUNG ANPASSBAR, SIE KÖNNEN SIE AUSSERDEM MIT WERBEBANNERN AUSSTATTEN
- LAS DIMENSIONES, COLORES Y ACABADOS DE LAS ESTRUCTURAS SE PUEDEN PERSONALIZAR, TAMBIÉN ES POSIBLE COLOCAR PANELES PUBLICITARIOS

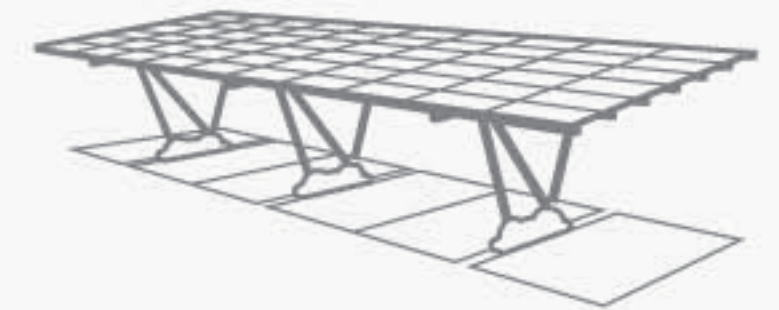

THE COMPANY DOES NOT SUPPLY SOLAR PANELS

- L'impianto fotovoltaico non è fornito dall'azienda
- Le système photovoltaïque n'est pas fourni par la société
- Die Photovoltaikanlage wird nicht von unserer Firma geliefert
- La empresa no suministra la instalación fotovoltaica





STRUCTURE DIMENSIONS

IT - DIMENSIONI DELLA STRUTTURA
FR - DIMENSIONS DE LA STRUCTURE
DE - ABMESSUNGEN DER STRUKTUR
ES - DIMENSIONES DE LA ESTRUCTURA

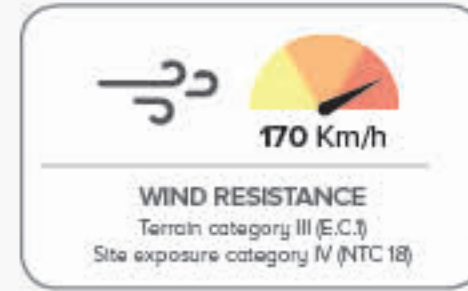

VERSION WITH CONCRETE BALLASTS

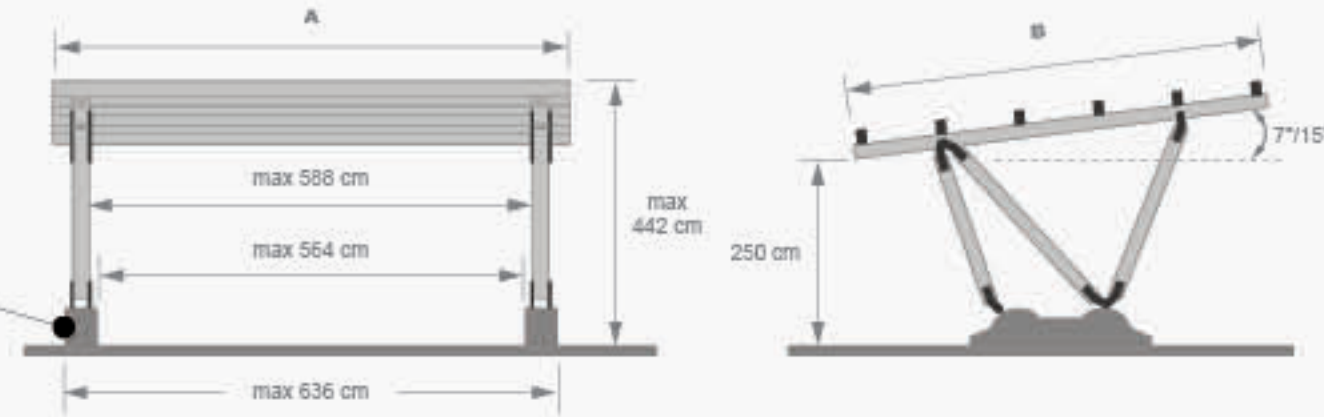

MAX DIMENSIONS	2 PARKING LOTS	3 PARKING LOTS	4 PARKING LOTS	5 PARKING LOTS	6 PARKING LOTS
	2 ballasts	2 ballasts	2 ballasts	3 ballasts	3 ballasts
	24 solar panels	30 solar panels	36 solar panels	48 solar panels	60 solar panels
SIDE A (cm)	670	837	1005	1340	1675
SIDE B (cm)	626	626	626	626	626

VERSION WITH ANCHOR PLATES FOR FIXING INTO CONCRETE SURFACES OR PLINTHS

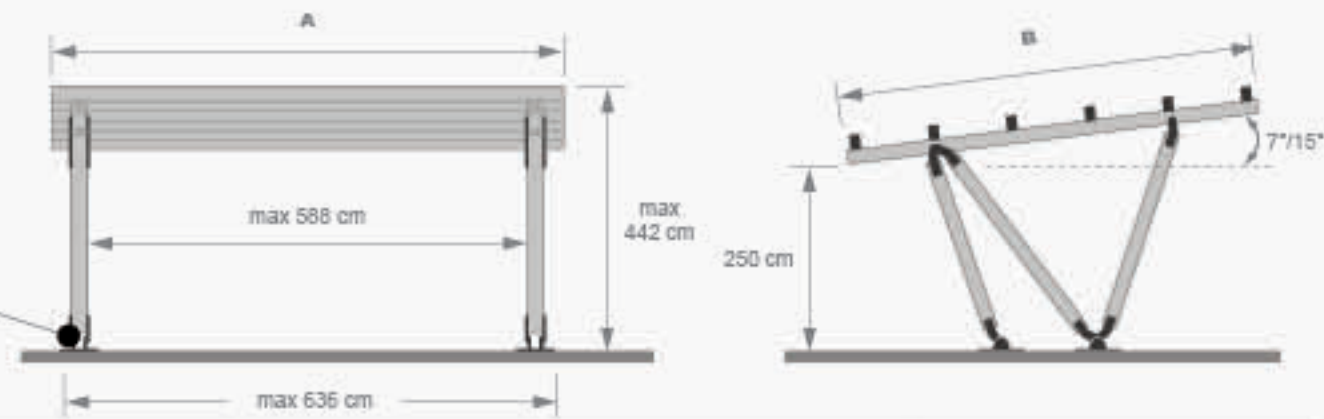
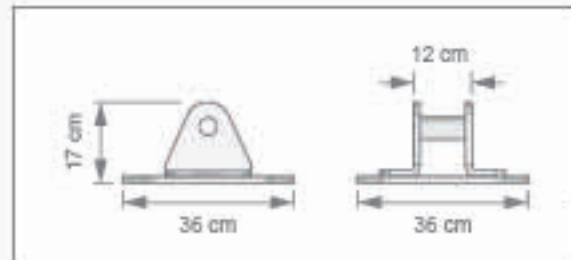

MAX DIMENSIONS	2 PARKING LOTS	3 PARKING LOTS	4 PARKING LOTS	5 PARKING LOTS	6 PARKING LOTS
	4 plates	4 plates	4 plates	6 plates	6 plates
	24 solar panels	30 solar panels	36 solar panels	48 solar panels	60 solar panels
SIDE A (cm)	670	837	1005	1340	1675
SIDE B (cm)	626	626	626	626	626

Note: The dimensions of the structure can be tailored to meet customer's needs. The sizes on the table are based on a panel measuring 1660 mm x 990 mm.
IT - NB: Le dimensioni della struttura sono personalizzabili secondo la richiesta del cliente. Le misure riportate in tabella considerano un pannello fotovoltaico con dimensioni di 1660 mm x 990 mm.
FR - N.B. : Les dimensions de la structure sont personnalisables en fonction de la demande du client. Les mesures indiquées dans le tableau considèrent un panneau photovoltaïque avec dimensions 1660 mm x 990 mm.
DE - Anm: Die Masse der Struktur können auf Kundenwunsch angepasst werden. Die Masse in der Tabelle beziehen sich auf einen Modul 1660 mm x 990 mm.
ES - Nota: Las dimensiones de la estructura son personalizables según la demanda del cliente. Para las medidas en la tabla han sido consideradas las dimensiones de panel 1660 mm x 990 mm.



STRUCTURE DIMENSIONS

IT - DIMENSIONI DELLA STRUTTURA
FR - DIMENSIONS DE LA STRUCTURE
DE - ABMESSUNGEN DER STRUKTUR
ES - DIMENSIONES DE LA ESTRUCTURA

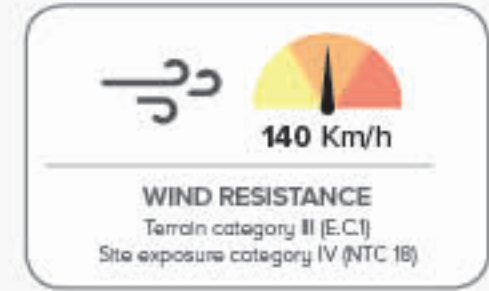

VERSION WITH CONCRETE BALLASTS

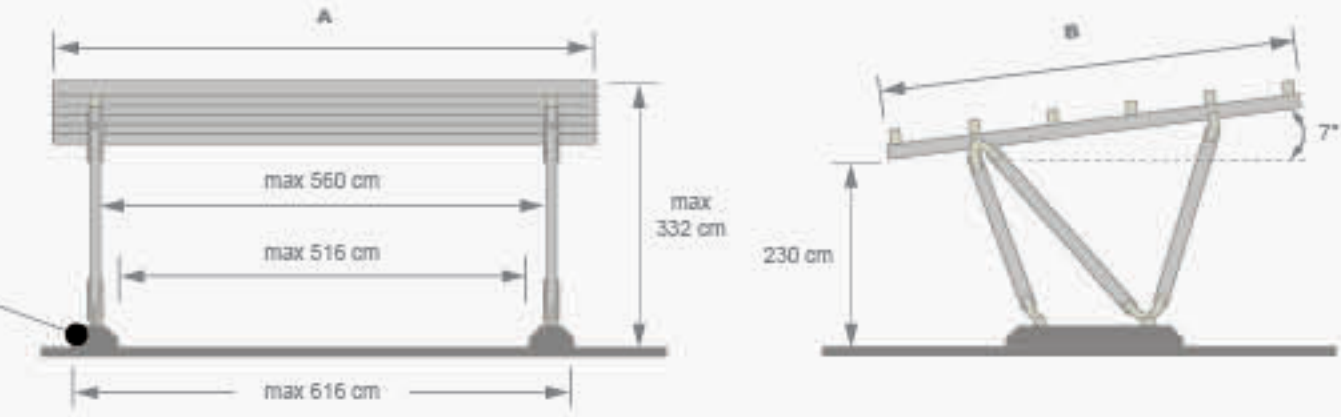
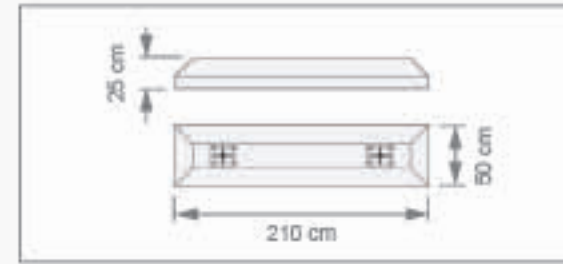

MAX DIMENSIONS	2 PARKING LOTS	3 PARKING LOTS	4 PARKING LOTS	5 PARKING LOTS	6 PARKING LOTS
	2 ballasts	2 ballasts	2 ballasts	3 ballasts	3 ballasts
	24 solar panels	30 solar panels	36 solar panels	54 solar panels	60 solar panels
SIDE A (cm)	670	837	1005	1508	1675
SIDE B (cm)	620	620	620	620	620

VERSION WITH ANCHOR PLATES FOR FIXING INTO CONCRETE SURFACES OR PLINTHS

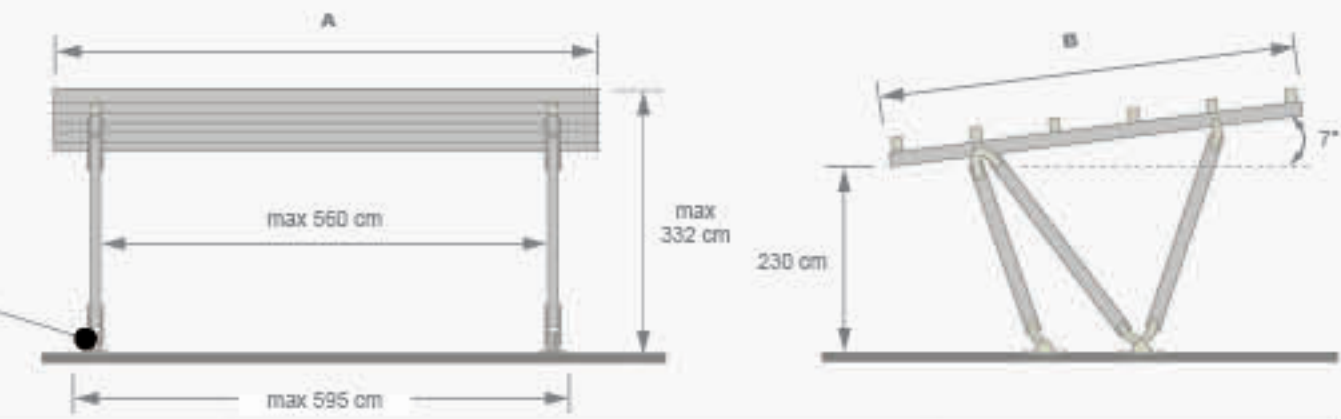
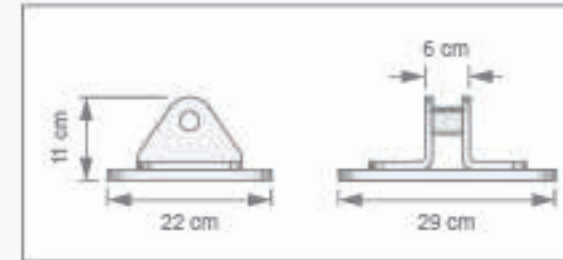

MAX DIMENSIONS	2 PARKING LOTS	3 PARKING LOTS	4 PARKING LOTS	5 PARKING LOTS	6 PARKING LOTS
	4 plates	4 plates	4 plates	6 plates	6 plates
	24 solar panels	30 solar panels	36 solar panels	54 solar panels	60 solar panels
SIDE A (cm)	670	837	1005	1508	1675
SIDE B (cm)	620	620	620	620	620

Note: The dimensions of the structure can be tailored to meet customer's needs. The sizes on the table are based on a panel measuring 1660 mm x 990 mm.
IT - NB: Le dimensioni della struttura sono personalizzabili secondo la richiesta del cliente. Le misure riportate in tabella considerano un pannello fotovoltaico con dimensioni di 1660 mm x 990 mm.
FR - N.B. : Les dimensions de la structure sont personnalisables en fonction de la demande du client. Les mesures indiquées dans le tableau considèrent un panneau photovoltaïque avec dimensions 1660 mm x 990 mm.
DE - Anm: Die Masse der Struktur können auf Kundenwunsch angepasst werden. Die Masse in der Tabelle beziehen sich auf einen Modul 1660 mm x 990 mm.
ES - Nota: Las dimensiones de la estructura son personalizables según la demanda del cliente. Para las medidas en la tabla han sido consideradas las dimensiones de panel 1660 mm x 990 mm.

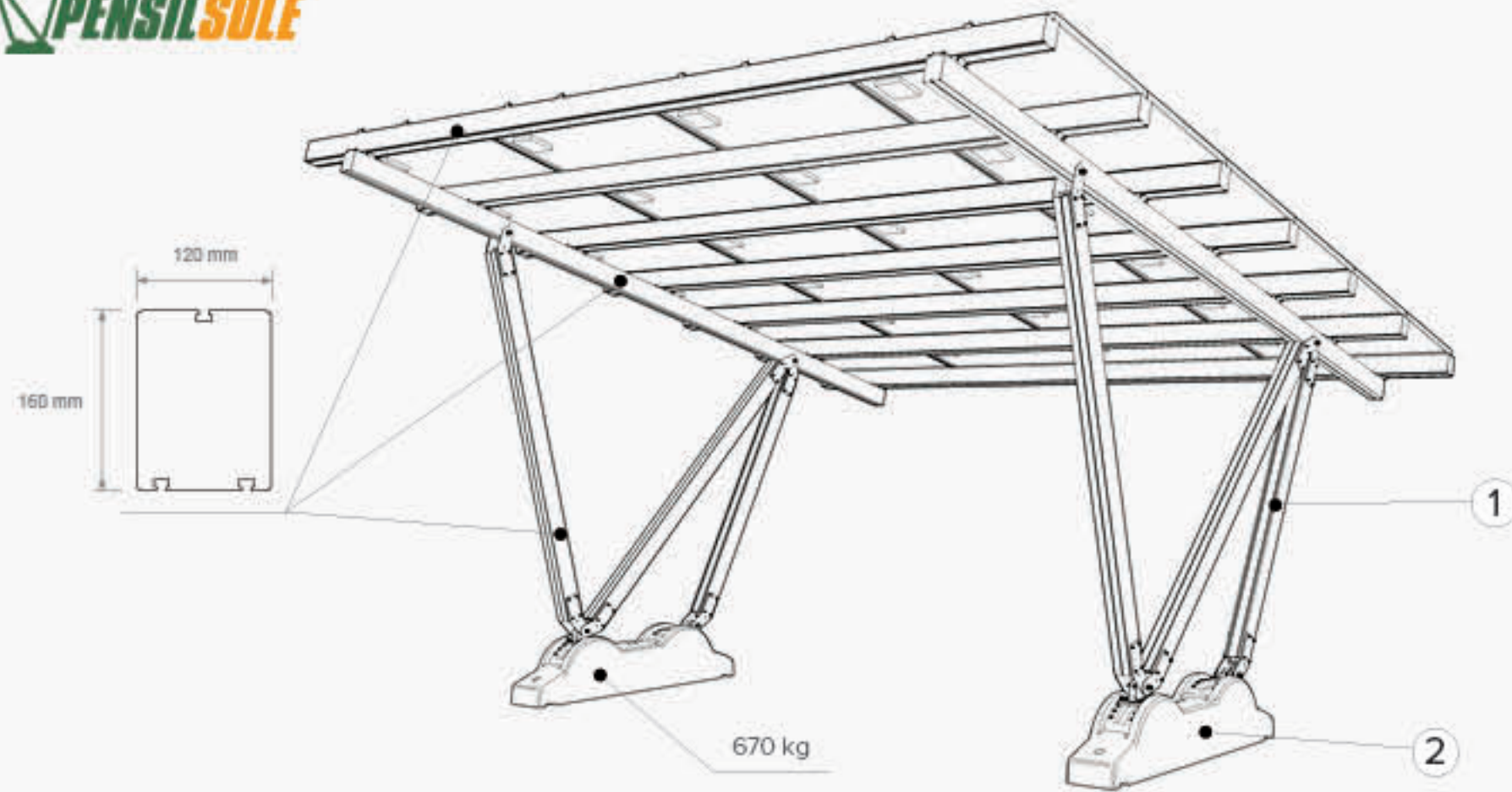

1 STANDARD COLOUR OF THE ALUMINIUM FRAME

IT - Colore standard della struttura in alluminio
 FR - Couleur standard de la structure en aluminium
 DE - Standardfarbe der Struktur in Aluminium
 ES - Color estándar de la estructura de aluminio

Silver anodised

2 CONCRETE BALLASTS WITH SANDBLASTED WHITE GRANITE FINISH

IT - Zavorra in cemento armato con finitura in granito bianco sabbato
 FR - Lestage en béton armé avec finition en granit blanc sablé
 DE - Zementfuss mit weissem, sandgestrahltem Granit-Finish
 ES - Lastre de cemento armado con acabado en granito blanco arenado

VERSION WITH CATAPHORESIS COATED AND VARNISHED ANCHOR PLATES FOR FIXING INTO CONCRETE SURFACES OR PLINTHS

IT - Versione con piastre in acciaio cataforesato e verniciato per ancoraggio su plinto o soletta in cemento
 FR - Version avec plaques d'ancrage au sol en acier laqué soumis à traitement de cataphorèse (anticorrosion) pour fixation sur socle ou semelle en béton armé
 DE - Ausführung mit Bodenankerplatten aus kataphorisiertem und lackiertem Stahl für Sockelverankerung oder Betonplatte
 ES - Versión con placas de acero tratado con cataforesis y esmaltado para anclaje a un plinto o base de cemento

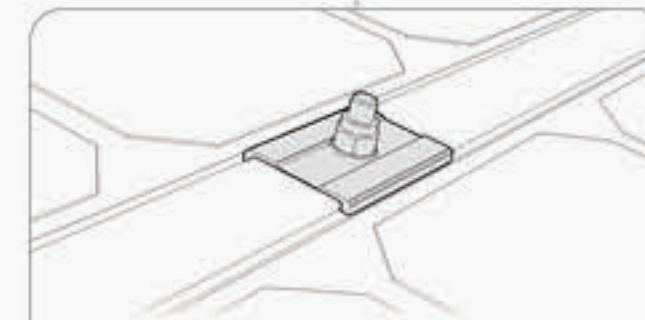
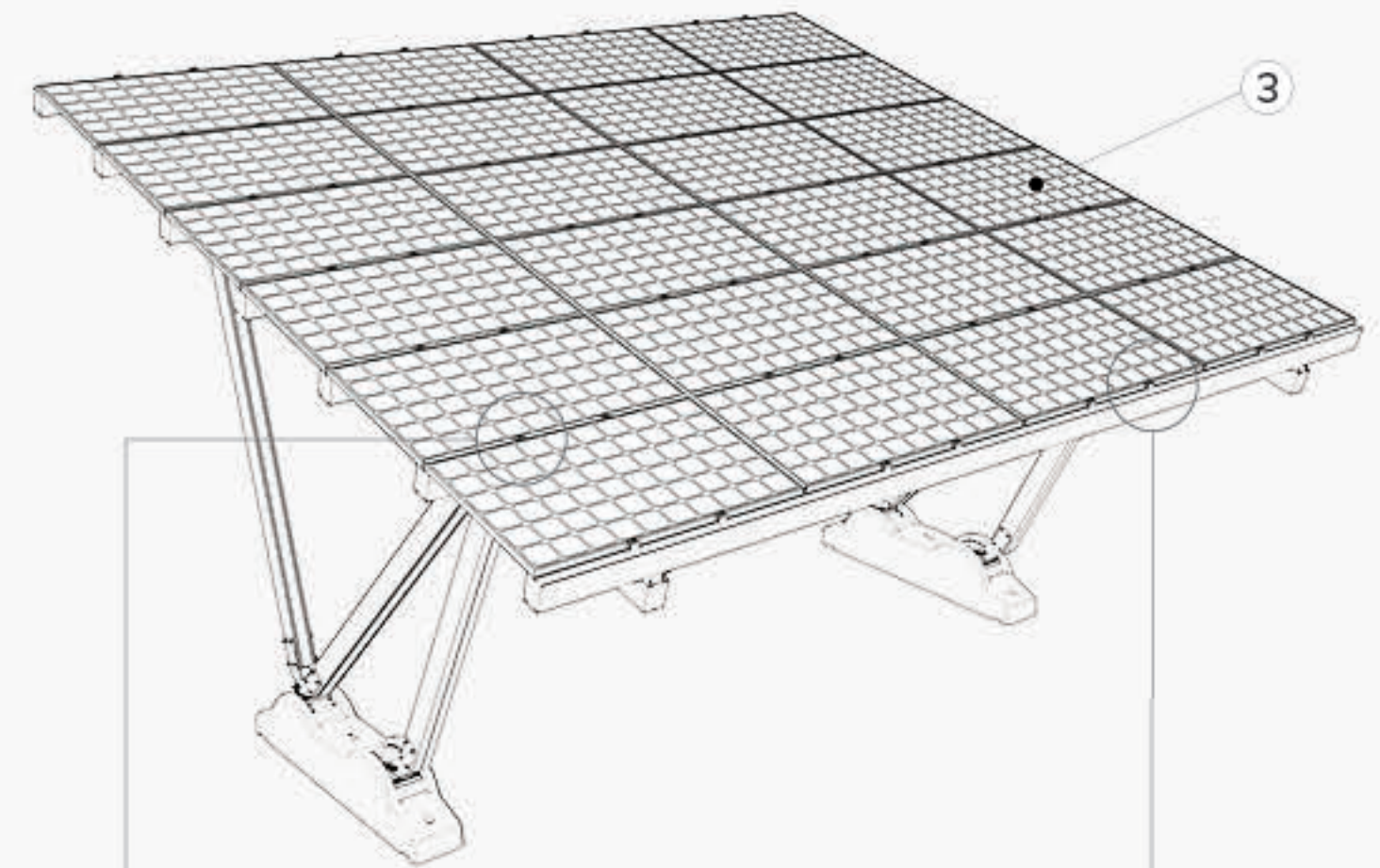
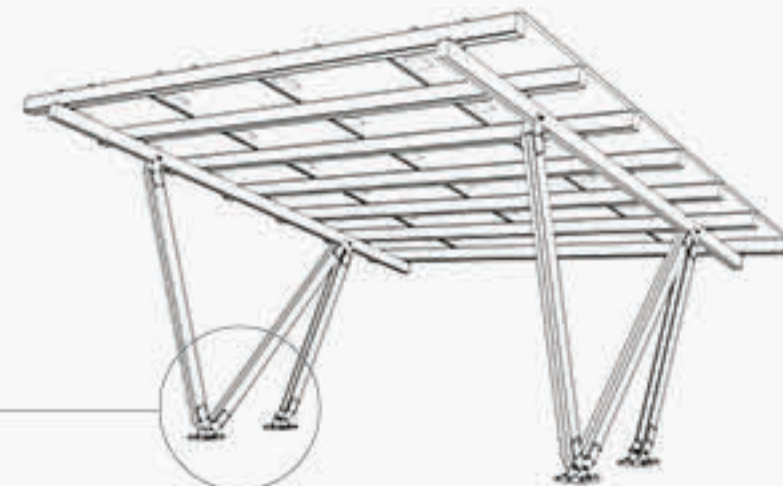

CENTRAL PANEL CLAMP

IT - Morsetto ferma pannello centrale
 FR - Bride de serrage panneau central
 DE - Klemme für zentrale Paneelfixierung
 ES - Abrazadera sujeta-panel central

THE QUICK FIXING SYSTEM FOR THE PANELS IS INCLUDED IN THE PRICE

IT: il sistema di fissaggio rapido dei pannelli è incluso nel prezzo
 FR: Le système de fixation rapide des panneaux est inclus dans le prix
 DE: Das Schnellbefestigungssystem der Paneele ist im Preis inbegriffen
 ES: El sistema de conexión rápida de los paneles va incluido en el precio

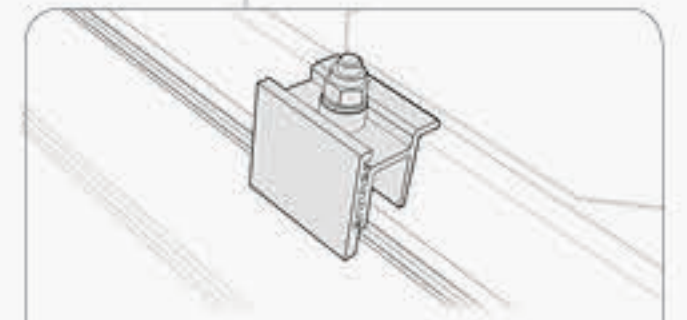

SIDE PANEL CLAMP

IT - Morsetto ferma pannello laterale
 FR - Bride de serrage panneau latéral
 DE - Klemme seitliche Paneelfixierung
 ES - Abrazadera sujeta-panel lateral

3 THE STRUCTURE SUPPORTS ANY MODEL AND SIZE OF SOLAR PANEL DUE TO ITS INTEGRATED QUICK FIXING SYSTEM (THE COMPANY DOES NOT SUPPLY SOLAR PANELS)

IT - La struttura supporta qualsiasi modello e dimensione di pannello fotovoltaico grazie ad un sistema di fissaggio rapido integrato. (L'impianto fotovoltaico non è fornito dall'azienda)
 FR - La structure supporte tous les modèles et dimensions de panneau photovoltaïque (La société ne fournit pas les panneaux photovoltaïques)
 DE - Die Struktur unterstützt jedes Modell und jede Größe von Photovoltaikmodulen durch ein integriertes Schnellbefestigungssystem. (Die Photovoltaikanlage wird nicht von unserer Firma geliefert)
 ES - La estructura sujeta cualquier modelo y tamaño de panel fotovoltaico gracias a un sistema de fijación rápido integrado. (La empresa no suministra la instalación fotovoltaica)

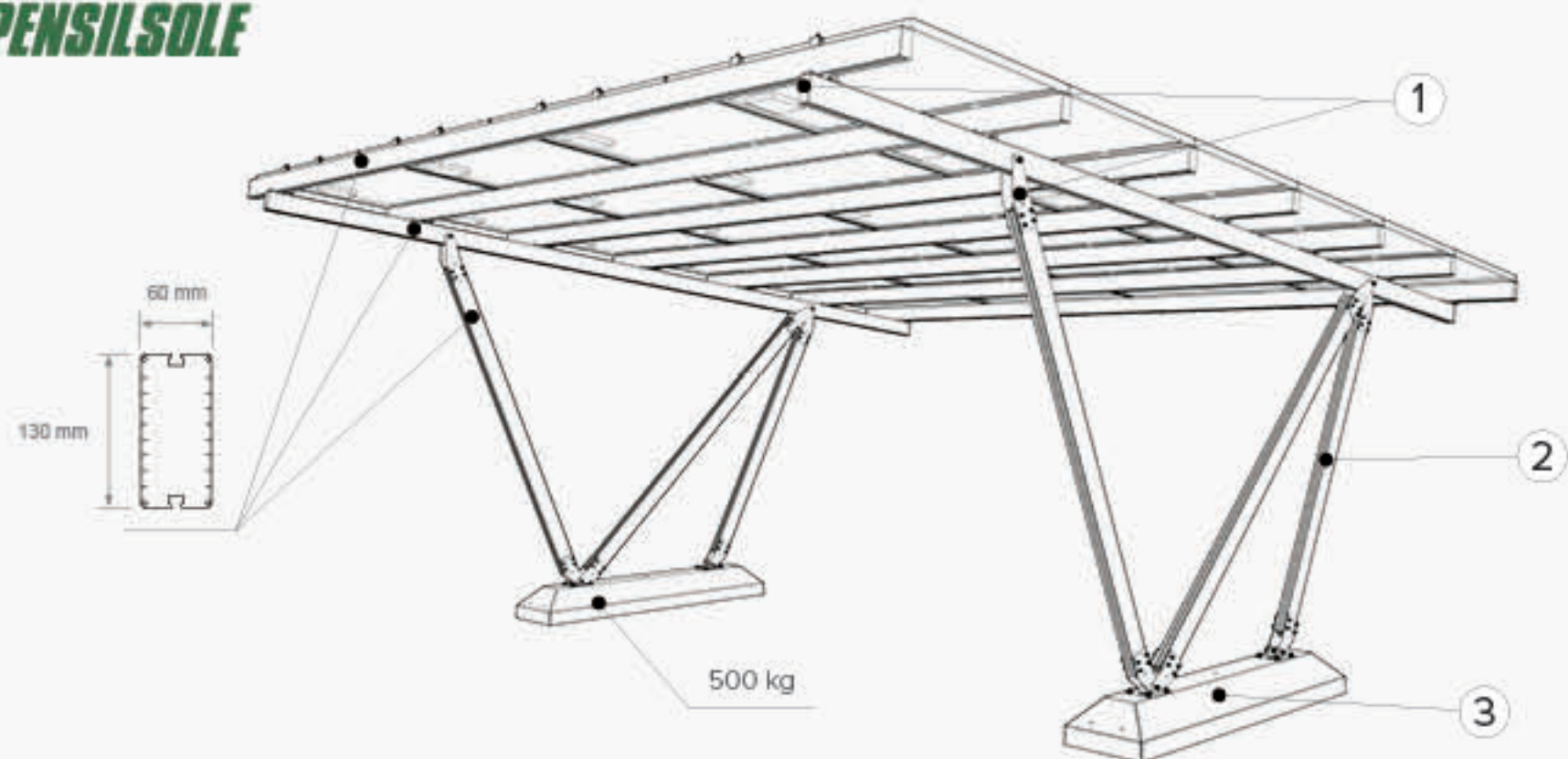

- 1** STANDARD COLOUR OF THE POWDER COATING OF THE ALUMINIUM CAPS AND CATHOPHORESIS TREATED STEEL PLATES
- IT - Colore standard della verniciatura dei tappi in alluminio e delle piastre in acciaio sottoposto a cataforesi
 FR - Couleur standard du laquage des bouchons en aluminium et des plaques en acier soumises à traitement de cathodèse (anticorrosion)
 DE - Standardfarbe von Aluminiumkappen und Stahlplatten kataphoretisch beschichtet und lackiert
 ES - Color estándar de la pintura en polvo de poliéster de los tapones en aluminio y de las placas de acero sometidas a cataforesis
- Ral 7044
- 2** STANDARD COLOUR OF THE ALUMINIUM FRAME
- IT - Colore standard della struttura in alluminio
 FR - Couleur standard de la structure en aluminium
 DE - Standardfarbe der Struktur in Aluminium
 ES - Color estándar de la estructura de aluminio
- Silver anodised
- 3** CONCRETE BALLASTS WITH SANDBLASTED WHITE GRANITE FINISH
- IT - Zavorra in cemento armato con finitura in granito bianco sabbato
 FR - Lestage en béton armé avec finition en granit blanc sablé
 DE - Zementfuss mit weissem, sandgestrahltem Granit-Finish
 ES - Lastre de cemento armado con acabado en granito blanco arenado

VERSION WITH CATHOPHORESIS COATED AND VARNISHED ANCHOR PLATES FOR FIXING INTO CONCRETE SURFACES OR PLINTHS

IT - Versione con piastre in acciaio cataforesato e verniciato per ancoraggio su plinto o soletta in cemento
 FR - Version avec plaques d'ancrage au sol en acier laqué soumis à traitement de cathodèse (anticorrosion) pour fixation sur socle ou semelle en béton armé
 DE - Ausführung mit Bodenankerplatten aus kataphorisiertem und lackiertem Stahl, für Sockelverankerung oder Betonplatte
 ES - Versión con placas de acero tratado con cataforesis y esmaltado para anclaje a un plinto o base de cemento

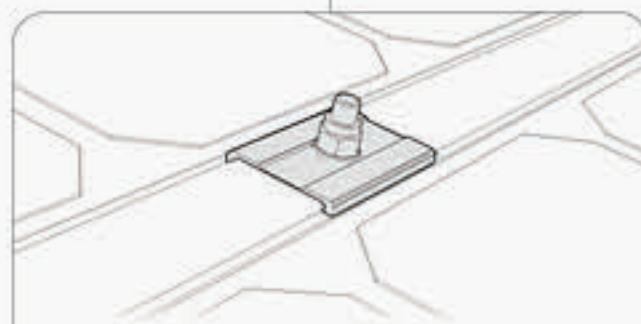
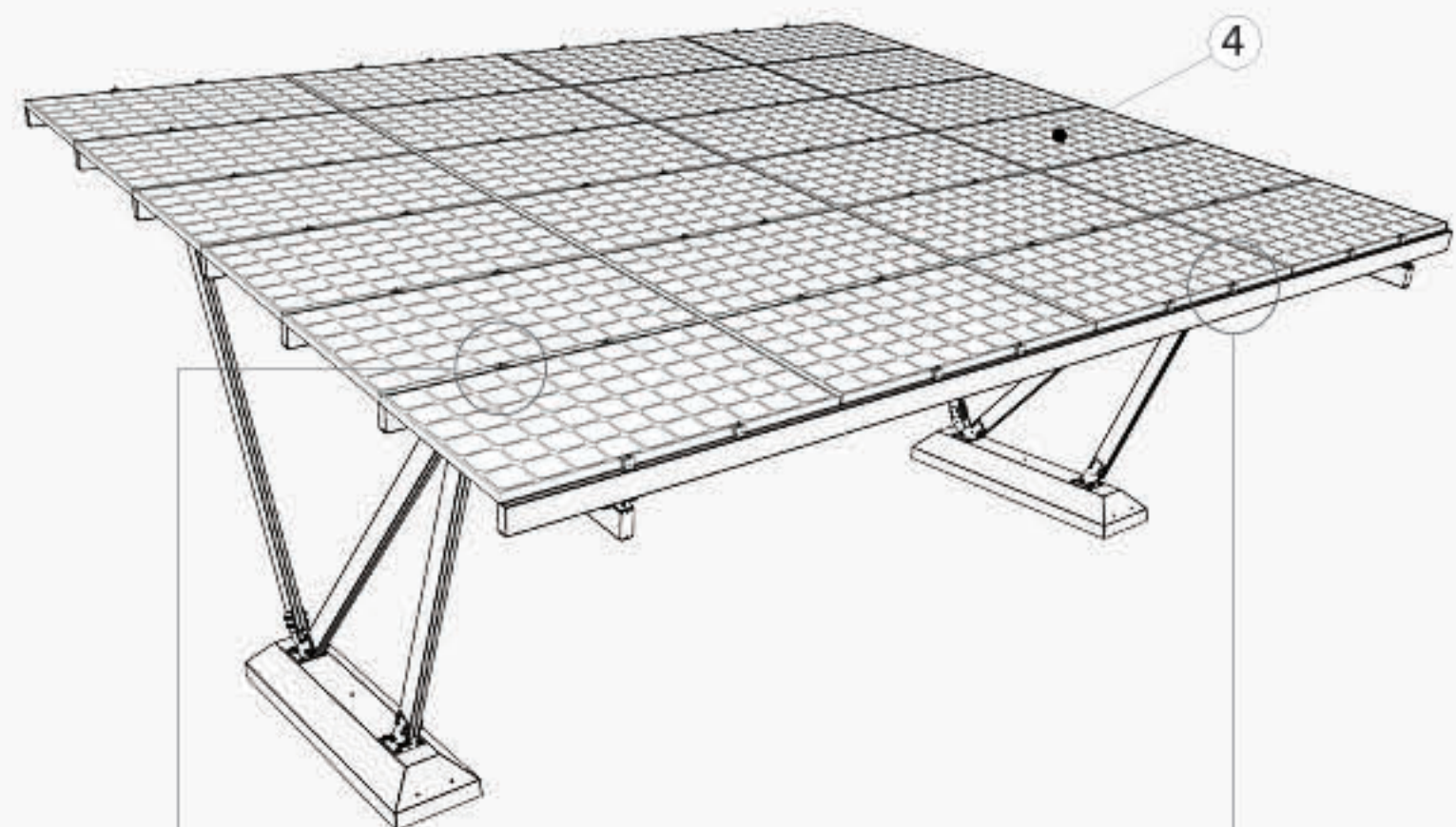
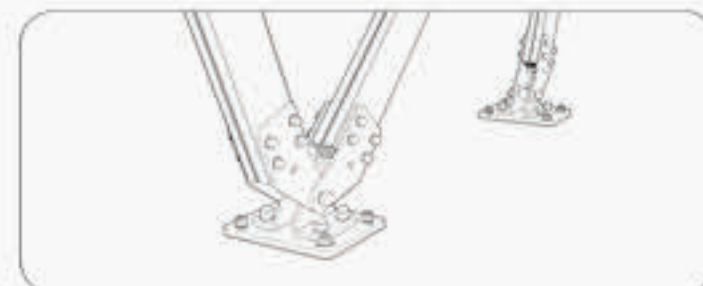

CENTRAL PANEL CLAMP

- IT - Morsetto ferma pannello centrale
 FR - Bride de serrage panneau central
 DE - Klemme für zentrale Paneelfixierung
 ES - Abrazadera sujeta-panel central

THE QUICK FIXING SYSTEM FOR THE PANELS IS INCLUDED IN THE PRICE

- IT: il sistema di fissaggio rapido dei pannelli è incluso nel prezzo
 FR: Le système de fixation rapide des panneaux est inclus dans le prix
 DE: Das Schnellbefestigungssystem der Paneele ist im Preis inbegriffen
 ES: El sistema de conexión rápida de los paneles va incluido en el precio

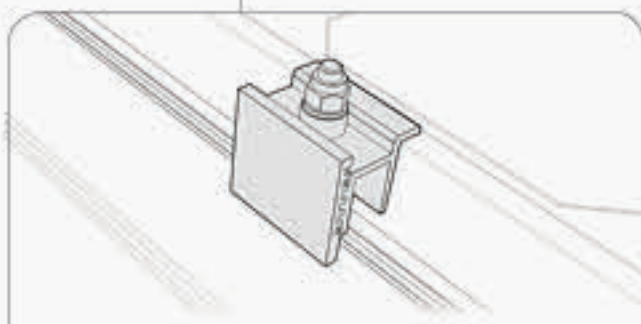

SIDE PANEL CLAMP

- IT - Morsetto ferma pannello laterale
 FR - Bride de serrage panneau latéral
 DE - Klemme seitliche Paneelfixierung
 ES - Abrazadera sujeta-panel lateral

4 THE STRUCTURE SUPPORTS ANY MODEL AND SIZE OF SOLAR PANEL DUE TO ITS INTEGRATED QUICK FIXING SYSTEM (THE COMPANY DOES NOT SUPPLY SOLAR PANELS)

- IT - La struttura supporta qualsiasi modello e dimensione di pannello fotovoltaico grazie ad un sistema di fissaggio rapido integrato. (L'impianto fotovoltaico non è fornito dall'azienda)
 FR - La structure supporte tous les modèles et dimensions de panneau photovoltaïque (La société ne fournit pas les panneaux photovoltaïques)
 DE - Die Struktur unterstützt jedes Modell und jede Größe von Photovoltaikmodulen durch ein integriertes Schnellbefestigungssystem. (Die Photovoltaikanlage wird nicht von unserer Firma geliefert)
 ES - La estructura sujeta cualquier modelo y tamaño de panel fotovoltaico gracias a un sistema de fijación rápido integrado. (La empresa no suministra la instalación fotovoltaica)

1990

100%

MADE IN ITALY

We are proud to have been manufacturing exclusively in Ferrara (Italy) since 1990



Follow Us!

www.giuliobarbieri.it



@GiulioBarbieriSrl



barbieri.coperture



Giulio Barbieri

MADE IN ITALY

Dal 1990 produciamo rigorosamente nel nostro stabilimento di Ferrara, Italia

MADE IN ITALY

Depuis 1990, nous produisons exclusivement dans notre établissement de Ferrara, Italie

MADE IN ITALY

Seit 1990 sind unsere Produkte exklusiv in unseren Werken in Ferrara, Italien produziert

MADE IN ITALY

Desde 1990, fabricamos exclusivamente en nuestra planta de Ferrara (Italia)