

# ELIX

The modern appeal of the flat lines and minimalist design make this family of products the ideal solution to satisfy a variety of needs. Elix comes in various formats and has an elegant perimeter micro frame which snaps open. It is also possible to make the product tamper proof so that the sections cannot be opened ensuring that the information displayed is protected. This versatile product can also be used with paper content.

*La modernità delle linee piatte e il design minimalista fanno di questa famiglia di prodotti la soluzione ideale per soddisfare molteplici esigenze. Disponibile in vari formati Elix si caratterizza per la presenza di una elegante micro cornice perimetrale apribile a scatto. E' altresì possibile dotare il sistema di antimanomissione che, impedendo l'apertura dei profili, garantisce la protezione della informazione presentata. La versatilità del prodotto permette anche la gestione su carta.*

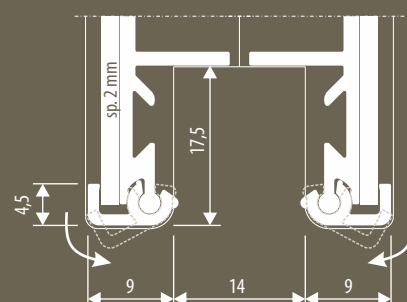
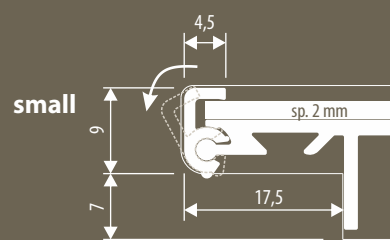
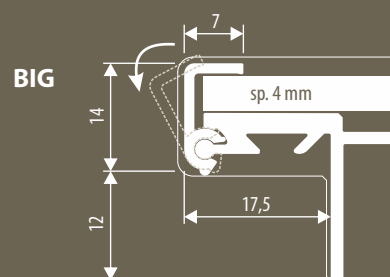

# ELIX

## WALL-MOUNTED PLATES TARGHE A PARETE

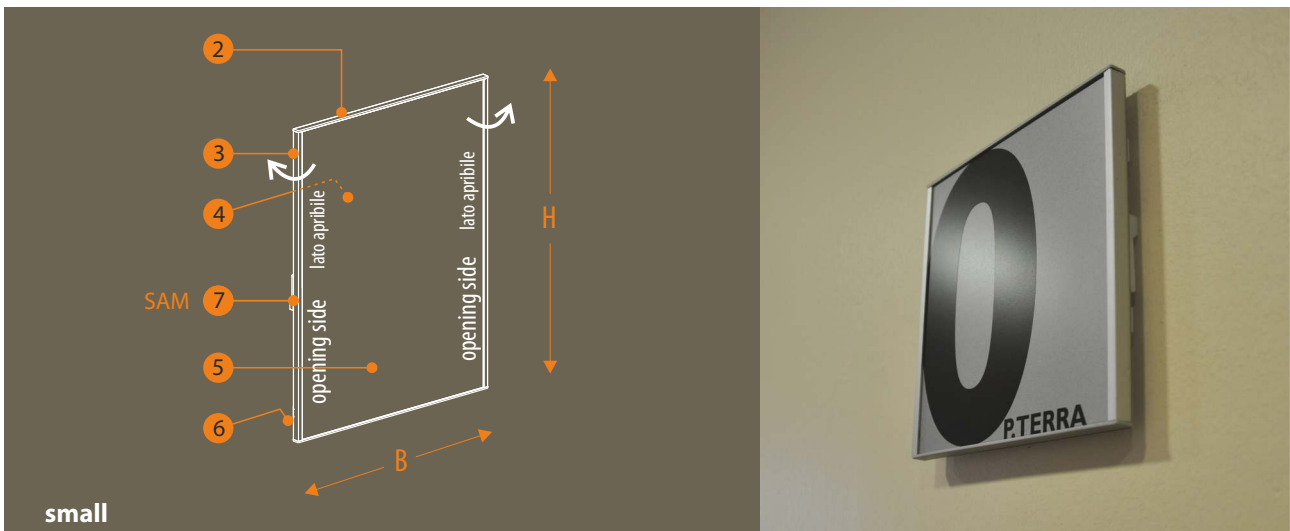
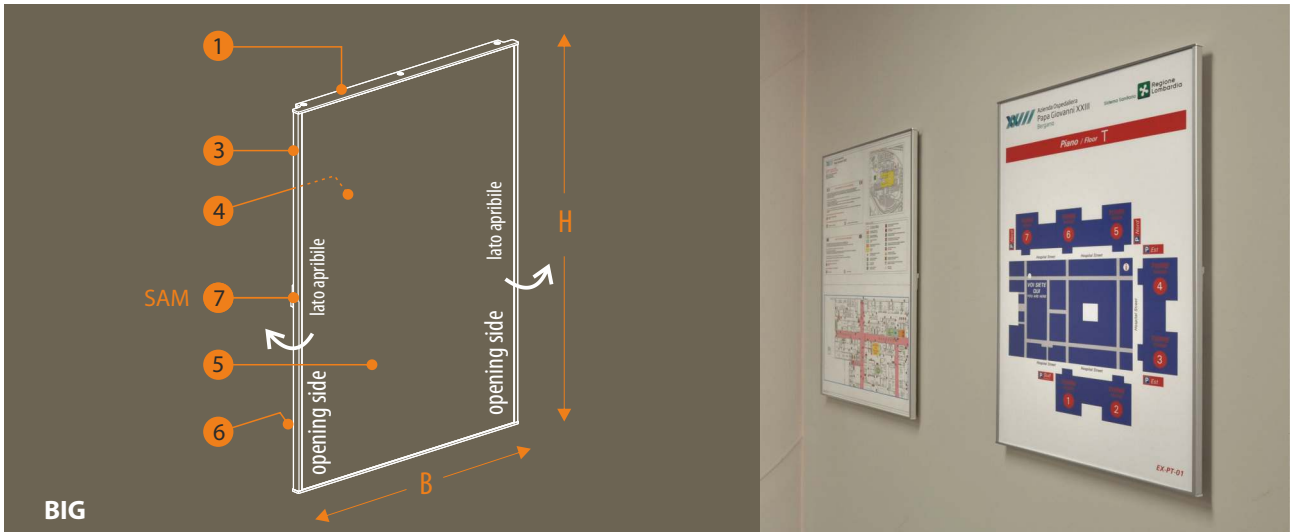

Starting from the base model the plate may be personalized by:

- dividing the panel in modules (A and B)
- applying a vinyl header on the front protection (C)

Partendo dal modello base è possibile personalizzare la targa agendo sulla pannellatura:

- scomponendola moduli (A e B)
- mettendo un'intestazione vinilica sulla protezione anteriore (C)

**A**

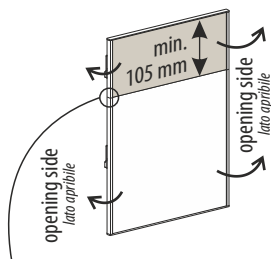

Separate opening profiles.  
Each part can be provided with tamper-proof system.  
**Module not lower than 105 mm in height.**  
*Profili di apertura suddivisi e apribili singolarmente.  
Ogni porzione può essere dotata di antimanomissione.  
Altezza minima per ogni modulo: 105 mm*

**B**

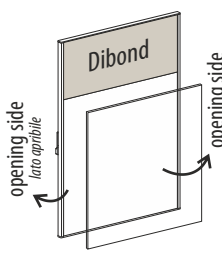

Single opening profile.  
Aluminium Composite sheet (Dibond) glued on the plate.  
*Profilo di apertura unico.  
Modulo in Dibond incollato alla targa.*

**C**

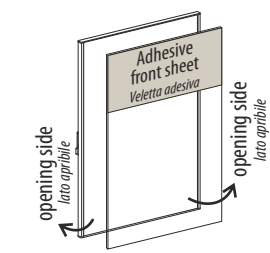

Single opening profile.  
Front protection with adhesive front sheet.  
*Profilo di apertura unico.  
Protezione anteriore con veletta adesiva.*

		Special height on demand (no more than 2100 mm) <i>H personalizzata (max 2100 mm)</i>			
1188		EL4.42120	EL4.60120	EL4.90120* <input type="checkbox"/>	EL4.120120* <input type="checkbox"/>
840		EL4.4290	EL4.6090	EL4.9090* <input type="checkbox"/>	EL4.12090* <input type="checkbox"/>
594		EL4.4260-T <input type="checkbox"/>	EL4.4260 <input type="checkbox"/>	EL4.6060 <input type="checkbox"/>	EL4.9060* <input type="checkbox"/>
420		EL4.3042 <input type="checkbox"/>	EL4.4242 <input type="checkbox"/>	EL4.6042 <input type="checkbox"/>	
297	EL4.1030	EL4.1530	EL4.2130 <input type="checkbox"/>	EL4.3030 <input type="checkbox"/>	EL4.4230 <input type="checkbox"/>
210	EL4.1021	EL4.1521 <input type="checkbox"/>	EL4.2121 <input type="checkbox"/>	EL4.3021 <input type="checkbox"/>	
148	EL4.1015 <input type="checkbox"/>	EL4.1515 <input type="checkbox"/>	EL4.2115 <input type="checkbox"/>	EL4.3015 <input type="checkbox"/>	
105 H	EL4.1010 <input type="checkbox"/>	EL4.1510 <input type="checkbox"/>	EL4.2110 <input type="checkbox"/>	EL4.3010 <input type="checkbox"/>	
		small		BIG	

\* Paper insert not available  
*Grafica su carta non disponibile*

Complete the code adding the suffix:  
*Completare il codice aggiungendo il suffisso:*

- **DB - PX** To choose the requested panel  
*Per identificare la pannellatura richiesta*
- + **SAM** To ask for tamper-proof system  
*Per richiedere il sistema di antimanomissione*

Dimensions refer to paper and panelling size  
*Le dimensioni si riferiscono alle dimensioni della carta o della pannellatura*

mill finish <i>grezzo</i>	white RAL 9016 <i>bianco RAL 9016</i>	silver RAL 9006 <i>silver RAL 9006</i>	silver anodized <i>anodizzato silver</i>
<input checked="" type="checkbox"/>	<input type="checkbox"/>	<input type="checkbox"/>	<input type="checkbox"/>

1	Aluminium end caps (only for BIG version) <i>Terminali in alluminio (solo per versione BIG)</i>				<input checked="" type="checkbox"/>
2	Plastic end caps: polycarbonate + abs (life-blend) (only for small version) <i>Terminali in plastica: policarbonato + ABS (Life-blend) (solo per versione small)</i>			<input checked="" type="checkbox"/>	
3	Aluminium opening profiles <i>Profili apribili in alluminio</i>				<input checked="" type="checkbox"/>
4	Aluminium basic profile (not in sight) <i>Profilo base (non in vista) in alluminio</i>	<input checked="" type="checkbox"/>			
5	- <b>DB</b> Aluminium Composite sheet panel (Dibond)(small: th. 2 mm / BIG th. 3 mm) <i>Pannellatura in dibond (small: sp. 2 mm / BIG sp. 3 mm)</i>		<input checked="" type="checkbox"/> Dibond	<input checked="" type="checkbox"/> Dibond	
	- <b>PX</b> Paper insert + transparent non-reflective polyester (PETG) th. 2 mm front protection + dibond background th. 2 mm <i>Grafica su carta + protezione anteriore in poliestere trasparente antiriflesso (PETG) sp. 2 mm + fondo in dibond sp. 2 mm</i>				
6	Opening springs (not in sight) in white techno-polymer <i>Molle di apertura (non in vista) in tecnopolimero bianco</i>				

# ELIX

## WALL-MOUNTED PLATES - LONG HORIZONTAL TARGHE A PARETE ORIZZONTALI

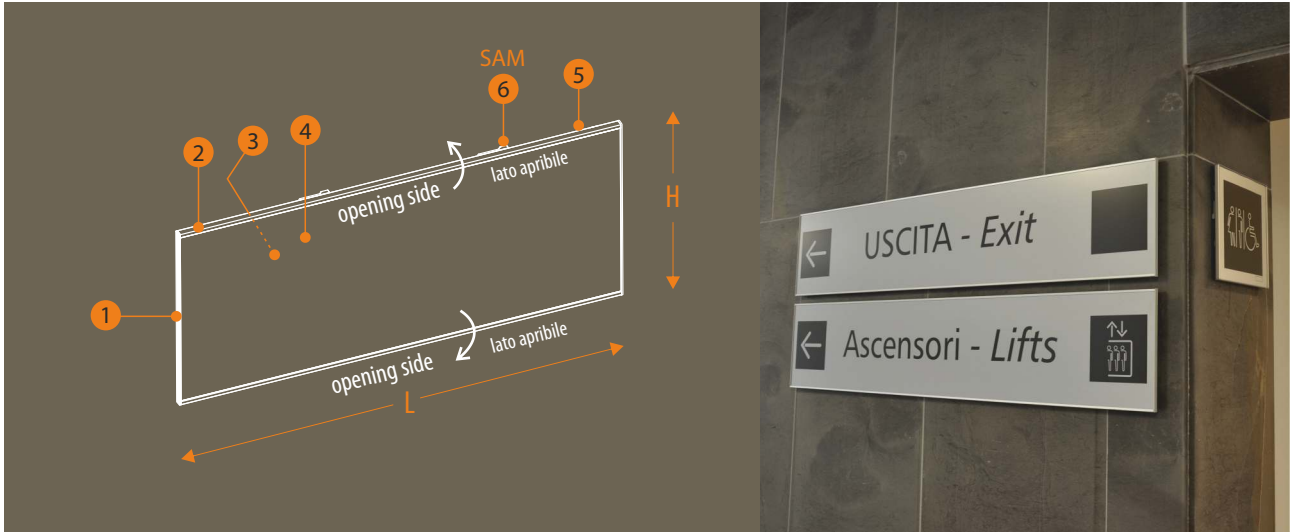

<b>297</b>	EL4.3050	EL4.3070	EL4.30105	<input checked="" type="checkbox"/>
<b>210</b>	EL4.2150	EL4.2170	EL4.21105	<input checked="" type="checkbox"/>
<b>148</b>	EL4.1550	EL4.1570	EL4.15105	<input checked="" type="checkbox"/>
<b>105</b>	EL4.1050	EL4.1070	EL4.10105	<input checked="" type="checkbox"/>

**H**

**L** 500 700 1050

Special lenght on demand  
(no more than 2100 mm)  
L personalizzata (max 2100 mm)

Complete the code adding the suffix:  
Completare il codice aggiungendo il suffisso:

**- DB - PX** To choose the requested panel  
Per identificare la pannellatura richiesta

**+ SAM** To ask for tamper-proof system  
Per richiedere il sistema di antimanomissione

Dimensions refer to paper and panelling size

Le dimensioni si riferiscono alle dimensioni della carta o della pannellatura

		mill finish grezzo	white RAL 9016 bianco RAL 9016	silver RAL 9006 silver RAL 9006	silver anodized anodizzato silver
<b>1</b>	Plastic end caps: polycarbonate + abs (life-blend) Terminali in plastica: policarbonato + ABS (Life-blend)	<input checked="" type="checkbox"/>	<input type="checkbox"/>	<input checked="" type="checkbox"/>	<input checked="" type="checkbox"/>
<b>2</b>	Aluminium opening profiles Profili apribili in alluminio	<input type="checkbox"/>	<input type="checkbox"/>	<input type="checkbox"/>	<input checked="" type="checkbox"/>
<b>3</b>	Aluminium basic profile (not in sight) Profilo base (non in vista) in alluminio	<input checked="" type="checkbox"/>	<input type="checkbox"/>	<input type="checkbox"/>	<input type="checkbox"/>
<b>4</b>	<b>- DB</b> Aluminium Composite sheet panel (Dibond) th. 2 mm Pannellatura in dibond sp. 2 mm	<input type="checkbox"/>	<input checked="" type="checkbox"/> Dibond	<input checked="" type="checkbox"/> Dibond	<input type="checkbox"/>
<b>4</b>	<b>- PX</b> Paper insert + transparent non-reflective polyester (PETG) th. 2 mm front protection + dibond background th. 2 mm Grafica su carta + protezione anteriore in poliestere trasparente antiriflesso (PETG) sp. 2 mm + fondo in dibond sp. 2 mm	<input type="checkbox"/>	<input type="checkbox"/>	<input type="checkbox"/>	<input type="checkbox"/>
<b>5</b>	Opening springs (not in sight) in white techno-polymer Molle di apertura (non in vista) in tecnopolimero bianco	<input type="checkbox"/>	<input type="checkbox"/>	<input type="checkbox"/>	<input type="checkbox"/>

# ELIX

## SUSPENDED PLATES

TARGHE SOSEPSE

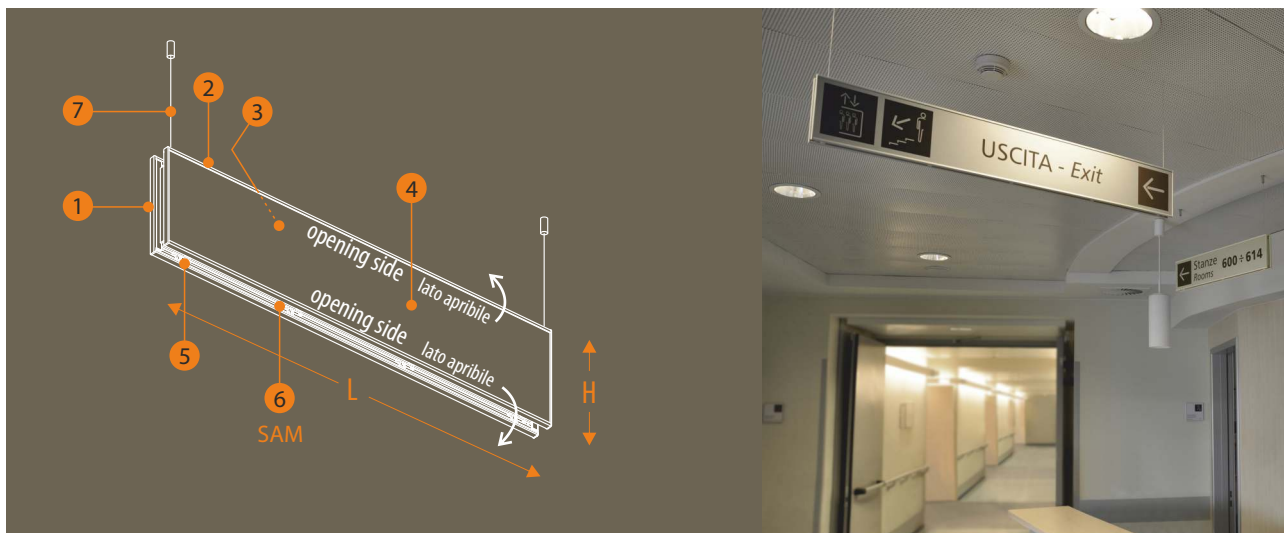

<b>297</b>	EL4.S7030	EL4.S10530	EL4.S12530	EL4.S15030	<input checked="" type="checkbox"/>
<b>210</b>	EL4.S7021	EL4.S10521	EL4.S12521	EL4.S15021	<input checked="" type="checkbox"/>
<b>148</b>	EL4.S7015	EL4.S10515	EL4.S12515	EL4.S15015	<input checked="" type="checkbox"/>
<b>105</b>	EL4.S7010	EL4.S10510	EL4.S12510	EL4.S15010	<input checked="" type="checkbox"/>

**H**

**L 700 1050 1250 1500**

Special lenght on demand (no more than 2100 mm)  
L personalizzata (max 2100 mm)

Complete the code adding the suffix:  
Completare il codice aggiungendo il suffisso:

**- DB - PX** To choose the requested panel  
Per identificare la pannellatura richiesta

**+ SAM** To ask for tamper-proof system  
Per richiedere il sistema di antimanomissione

Dimensions refer to paper and panelling size  
Le dimensioni si riferiscono alle dimensioni della carta o della pannellatura

		mill finish grezzo	white RAL 9016 bianco RAL 9016	silver RAL 9006 silver RAL 9006	silver anodized anodizzato silver
<b>1</b>	Plastic end caps: polycarbonate + abs (life-blend) Terminali in plastica: policarbonato + ABS (Life-blend)	<input checked="" type="checkbox"/>	<input type="checkbox"/>	<input checked="" type="checkbox"/>	<input checked="" type="checkbox"/>
<b>2</b>	Aluminium opening profiles Profili apribili in alluminio	<input type="checkbox"/>	<input type="checkbox"/>	<input type="checkbox"/>	<input checked="" type="checkbox"/>
<b>3</b>	Aluminium basic profile (not in sight) Profilo base (non in vista) in alluminio	<input checked="" type="checkbox"/>	<input type="checkbox"/>	<input type="checkbox"/>	<input type="checkbox"/>
<b>4</b>	<b>- DB</b> Aluminium Composite sheet panel (Dibond) th. 2 mm Pannellatura in dibond sp. 2 mm	<input type="checkbox"/>	<input checked="" type="checkbox"/> Dibond	<input checked="" type="checkbox"/> Dibond	<input type="checkbox"/>
	<b>- PX</b> Paper insert + transparent non-reflective polyester (PETG) th. 2 mm front protection + dibond background th. 2 mm Grafica su carta + protezione anteriore in poliestere trasparente antiriflesso (PETG) sp. 2 mm + fondo in dibond sp. 2 mm	<input type="checkbox"/>	<input type="checkbox"/>	<input type="checkbox"/>	<input type="checkbox"/>
<b>5</b>	Opening springs (not in sight) in white techno-polymer Molle di apertura (non in vista) in tecnopolimero bianco	<input type="checkbox"/>	<input type="checkbox"/>	<input type="checkbox"/>	<input type="checkbox"/>
<b>7</b>	Suspension kit composed by: plasticized steel cables, automatic suspending clamps in chromium brass Kit di sospensione composto da: cavi in acciaio plastificato, morsetti a soffitto automatici in ottone cromato	<input type="checkbox"/>	<input type="checkbox"/>	<input type="checkbox"/>	<input type="checkbox"/>

# ELIX PROJECTING PLATES

## TARGHE A BANDIERA

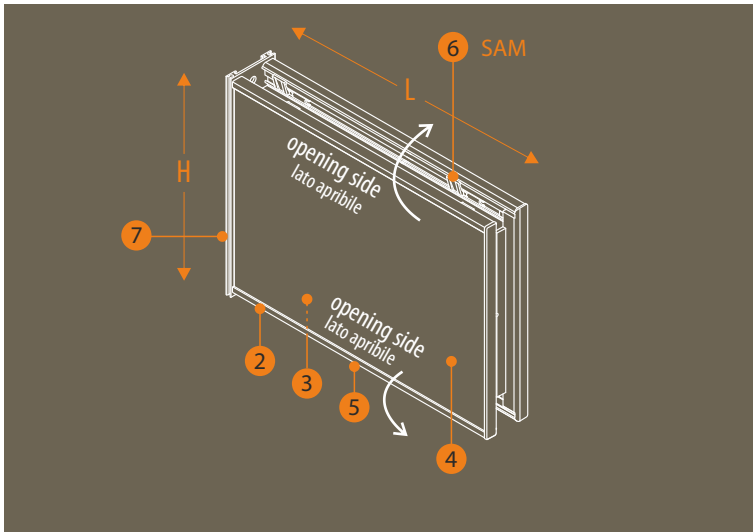

210		A5		A4
	EL4.B1021	EL4.B1521	EL4.B2121	EL4.B3021
148	A6		A5	
	EL4.B1015	EL4.B1515	EL4.B2115	EL4.B3015
105		A6		
	EL4.B1010	EL4.B1510	EL4.B2110	EL4.B3010
H				

Complete the code adding the suffix:  
Completare il codice aggiungendo il suffisso:

- DB - PX To choose the requested panel  
Per identificare la pannellatura richiesta

+ SAM To ask for tamper-proof system  
Per richiedere il sistema di antimanomissione

Dimensions refer to paper and panelling size

Le dimensioni si riferiscono alle dimensioni della carta o della pannellatura

		mill finish grezzo	white RAL 9016 bianco RAL 9016	silver RAL 9006 silver RAL 9006	silver anodized anodizzato silver
1	Plastic end caps: polycarbonate + abs (life-blend) Terminali in plastica: policarbonato + ABS (Life-blend)	<input checked="" type="checkbox"/>	<input type="checkbox"/>	<input checked="" type="checkbox"/>	<input checked="" type="checkbox"/>
2	Aluminium opening profiles Profili apribili in alluminio	<input type="checkbox"/>	<input type="checkbox"/>	<input type="checkbox"/>	<input checked="" type="checkbox"/>
3	Aluminium basic profile (not in sight) Profilo base (non in vista) in alluminio	<input checked="" type="checkbox"/>	<input type="checkbox"/>	<input type="checkbox"/>	<input type="checkbox"/>
4	- DB Aluminium Composite sheet panel (Dibond) th. 2 mm Pannellatura in dibond sp. 2 mm - PX Paper insert + transparent non-reflective polyester (PETG) th. 2 mm front protection + dibond background th. 2 mm Grafica su carta + protezione anteriore in poliestere trasparente antiriflesso (PETG) sp. 2 mm + fondo in dibond sp. 2 mm	<input type="checkbox"/>	<input checked="" type="checkbox"/> Dibond	<input checked="" type="checkbox"/> Dibond	<input type="checkbox"/>
5	Opening springs (not in sight) in white techno-polymer Molle di apertura (non in vista) in tecnopolimero bianco	<input type="checkbox"/>	<input type="checkbox"/>	<input type="checkbox"/>	<input type="checkbox"/>
7	Projecting system coupling in aluminium Supporto a bandiera in alluminio	<input type="checkbox"/>	<input type="checkbox"/>	<input type="checkbox"/>	<input checked="" type="checkbox"/>



# ELIX REPLACEMENT OF THE GRAPHIC / PANELLING

## SOSTITUZIONE DELLA CARTA / PANNELLATURA

To remove the front panel, side profiles must be opened.

If the plate has a tamper-proof system (SAM), please unlock it before opening the side profiles.

Per rimuovere la pannellatura / protezione anteriore è necessario aprire a scatto i profili laterali.

Se il segnale fosse dotato di sistema di antimanomissione (SAM) l'apertura dei profili laterali è consentita solo previo sblocco del SAM.

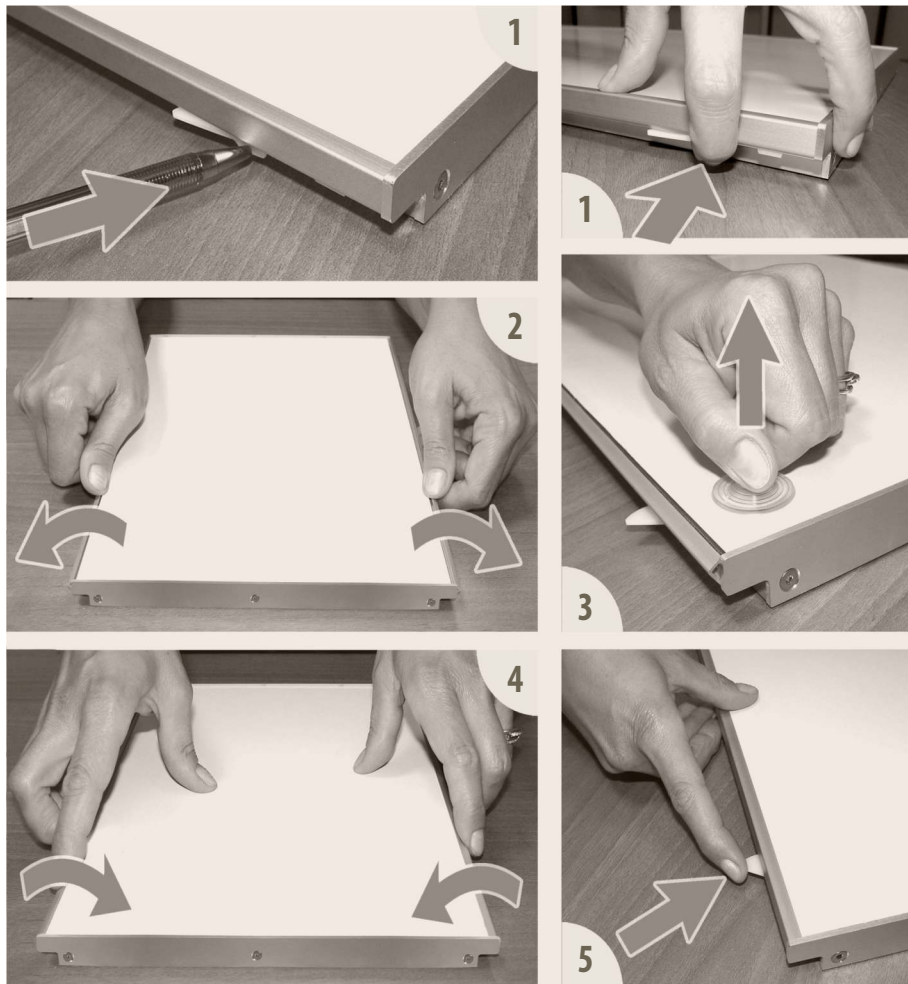

1)  
**UNLOCK THE TAMPER-PROOF SYSTEM**  
pushing the lever and letting it appear.  
If you can't with a finger, use a stiff tool.  
*SBLOCCARE L'ANTIMANOMISSIONE*  
spingendo la leva fino a farla comparire.  
Se non si dovesse riuscire con un dito,  
aiutarsi con un utensile rigido.

2)  
**OPEN THE PLATE**  
acting on side profiles.  
*SBLOCCARE L'ANTIMANOMISSIONE*  
spingendo la leva fino a farla comparire.  
Se non si dovesse riuscire con un dito,  
aiutarsi con un utensile rigido.

3)  
**REMOVE and REPLACE**  
panelling (or paper) with the help  
of a suction pad  
*SBLOCCARE L'ANTIMANOMISSIONE*  
spingendo la leva fino a farla comparire.  
Se non si dovesse riuscire con un dito,  
aiutarsi con un utensile rigido.

4)  
**CLOSE THE PLATE** acting on  
side profiles  
*RICHIUDERE LA TARGA* agendo sui  
profili laterali

5)  
**LOCK THE TAMPER-PROOF SYSTEM**  
pushing the lever towards the plate  
and letting it disappear.  
*INSERIRE L'ANTIMANOMISSIONE*  
spingendo la leva verso la targa fino  
a farla scomparire.

### TAMPER-PROOF SYSTEM (SAM)

A tamper-proof system may be mounted on each size profile to avoid the removal of the front panelling. When it is closed the system is hidden on the back of the plate so only the authorized personnel is able to unlock it. The opening/closing of the SAM is done without any particular tool.

#### SISTEMA DI ANTIMANOMISSIONE

Qualora si necessitasse di protezione contro la rimozione non autorizzata di moduli è possibile dotare ogni profilo laterale di sistema antimanomissione a scomparsa che, se inserito, impedisce l'apertura del profilo stesso e quindi la rimozione della pannellatura frontale. Una volta inserito il sistema di antimanomissione scompare alla vista e quindi solo il personale autorizzato sa dove intervenire per sbloccarlo. Infatti per disinsertirlo è sufficiente spingere la leva nascosta nella zona retrostante; una volta aperto il sistema di antimanomissione diviene visibile così facendo non si rischia che rimanga accidentalmente disinserto.

Per inserirlo è sufficiente respingere la leva verso il profilo laterale. L'inserimento/rimozione del sistema di antimanomissione avviene senza l'ausilio di utensili specifici. Durante queste operazioni tutti i componenti rimangono solidali alla targa.

Sistema di antimanomissione è disponibile su richiesta per tutti i modelli.



Tamper-proof system OFF  
*Antimanomissione DISINSERTITA (targa apribile)*

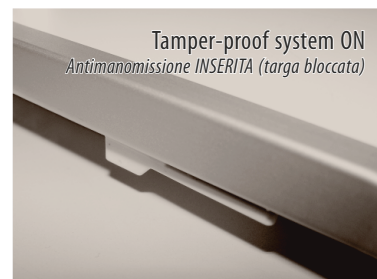

Tamper-proof system ON  
*Antimanomissione INSERITA (targa bloccata)*



# ELIX NF

The modern appeal of the flat lines and minimalist design make this family of products the ideal solution to satisfy a variety of needs. Designed as an expansion of the Elix line, the Elix NF has an elegant fixed perimeter micro frame. It is ideal when the content has to be changed rarely and where paper is not used.

*La modernità delle linee piatte e il design minimalista fanno di questa famiglia di prodotti la soluzione ideale per soddisfare molteplici esigenze. Nata come espansione della linea Elix, Elix NF si caratterizza per la presenza di una elegante micro cornice perimetrale fissa. Ideale quando i contenuti sono soggetti a rare modifiche e dove non è prevista la gestione su carta.*

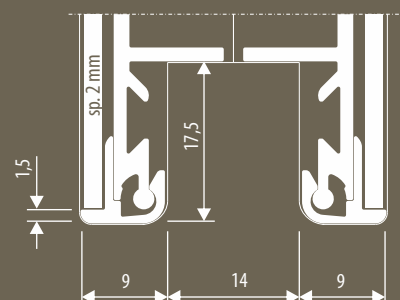
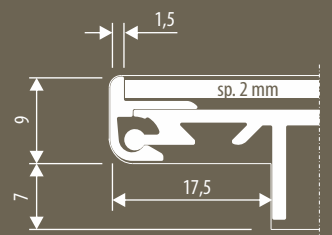

# ELIX NF WALL-MOUNTED PLATES TARGHE A PARETE

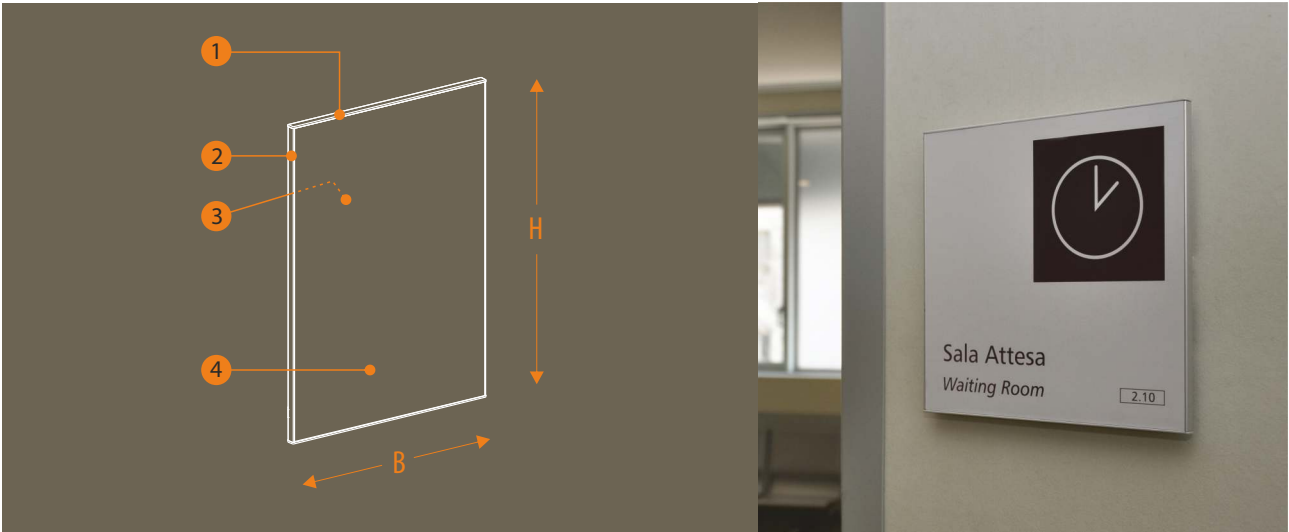

Special height on demand (no more than 2100 mm) <i>H personalizzata (max 2100 mm)</i>				
594				A2 EL4.4260-T-NF
420				A3 EL4.3042-NF
297	EL4.1030-NF	EL4.1530-NF	EL4.2130-NF	A4 EL4.3030-NF
210	EL4.1021-NF	EL4.1521-NF	EL4.2121-NF	A5 EL4.3021-NF
148	EL4.1015-NF	EL4.1515-NF	EL4.2115-NF	A5 EL4.3015-NF
105 H	EL4.1010-NF	EL4.1510-NF	EL4.2110-NF	A6 EL4.3010-NF

**B** 105 148 210 297 420

Dimensions refer to panelling size  
*Le dimensioni si riferiscono alle dimensioni della pannellatura*

The plate is well clipped to end caps and it is also possible to swap one plate with another one. The removal of the plate, in fact, is not a cause of damage neither for end caps nor for the plate itself; this one can be reused and clipped again in another place.

*La targa rimane ben solidale ai terminali, tuttavia è possibile interscambiare le targhe. Infatti la rimozione della targa non danneggia né i terminali né la targa stessa, che potrà essere riutilizzata e riagganciata altrove.*

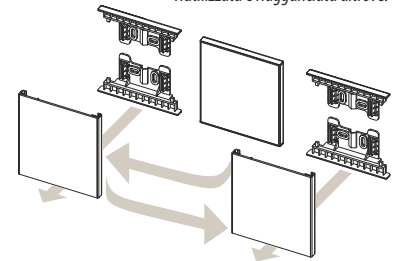

mill finish <i>grezzo</i>	white RAL 9016 <i>bianca RAL 9016</i>	silver RAL 9006 <i>silver RAL 9006</i>	silver anodized <i>anodizzato silver</i>
<input checked="" type="checkbox"/>	<input type="checkbox"/>	<input type="checkbox"/>	<input type="checkbox"/>

1	Plastic end caps: polycarbonate + abs (life-blend) <i>Terminali in plastica: policarbonato + ABS (Life-blend)</i>		<input checked="" type="checkbox"/>	<input checked="" type="checkbox"/>
2	Aluminium side profiles (fixed) <i>Profili laterali fissi in alluminio</i>			<input checked="" type="checkbox"/>
3	Aluminium basic profile (not in sight) <i>Profilo base (non in vista) in alluminio</i>	<input checked="" type="checkbox"/>		
4	Aluminium Composite sheet panel (Dibond) th. 2 mm <i>Pannellatura in dibond sp. 2 mm</i>		<input checked="" type="checkbox"/>	<input checked="" type="checkbox"/>

# ELIX NF WALL-MOUNTED PLATES - LONG HORIZONTAL

## TARGHE A PARETE ORIZZONTALI

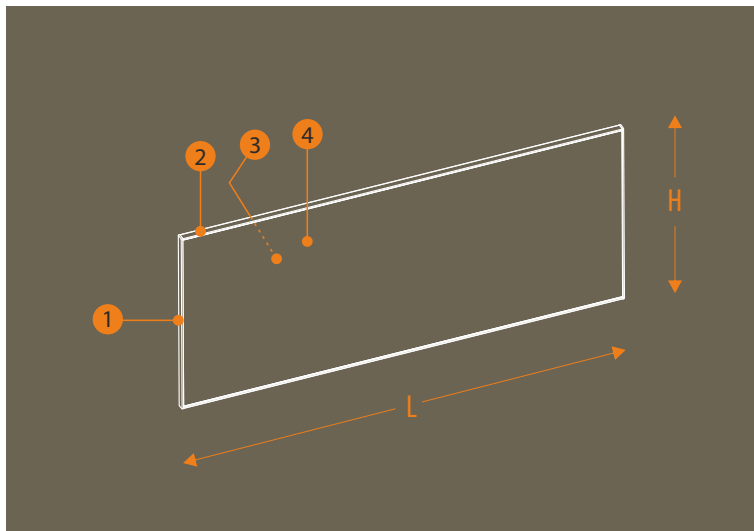

<b>297</b>	EL4.3050-NF	EL4.3070-NF	EL4.30105-NF	<input checked="" type="checkbox"/>
<b>210</b>	EL4.2150-NF	EL4.2170-NF	EL4.21105-NF	<input checked="" type="checkbox"/>
<b>148</b>	EL4.1550-NF	EL4.1570-NF	EL4.15105-NF	<input checked="" type="checkbox"/>
<b>105</b>	EL4.1050-NF	EL4.1070-NF	EL4.10105-NF	<input checked="" type="checkbox"/>

**H**

**L** 500 700 1050

Special length on demand (no more than 2100 mm)  
L personalizzata (max 2100 mm)

Dimensions refer to panelling size  
Le dimensioni si riferiscono alle dimensioni della pannellatura

The plate is well clipped to end caps and it is also possible to swap one plate with another one. The removal of the plate, in fact, is not a cause of damage neither for end caps nor for the plate itself; this one can be reused and clipped again in another place.

La targa rimane ben solidale ai terminali, tuttavia è possibile interscambiare le targhe. Infatti la rimozione della targa non danneggia ne i terminali ne la targa stessa, che potrà essere riutilizzata e riagganciata altrove.

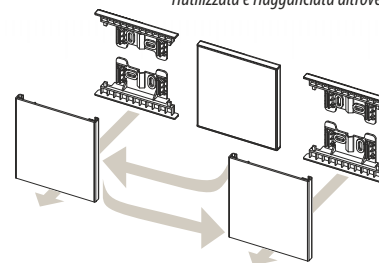

	mill finish grezzo	white RAL 9016 bianco RAL 9016	silver RAL 9006 silver RAL 9006	silver anodized anodizzato silver
<b>1</b> Plastic end caps: polycarbonate + abs (life-blend) Terminali in plastica: policarbonato + ABS (Life-blend)	<input checked="" type="checkbox"/>	<input type="checkbox"/>	<input checked="" type="checkbox"/>	<input checked="" type="checkbox"/>
<b>2</b> Aluminium side profiles (fixed) Profili laterali fissi in alluminio	<input type="checkbox"/>	<input type="checkbox"/>	<input type="checkbox"/>	<input checked="" type="checkbox"/>
<b>3</b> Aluminium basic profile (not in sight) Profilo base (non in vista) in alluminio	<input checked="" type="checkbox"/>	<input type="checkbox"/>	<input type="checkbox"/>	<input type="checkbox"/>
<b>4</b> Aluminium Composite sheet panel (Dibond) th. 2 mm Pannellatura in dibond sp. 2 mm	<input type="checkbox"/>	<input checked="" type="checkbox"/>	<input checked="" type="checkbox"/>	<input type="checkbox"/>

# ELIX NF

## SUSPENDED PLATES

### TARGHE SOSPESE

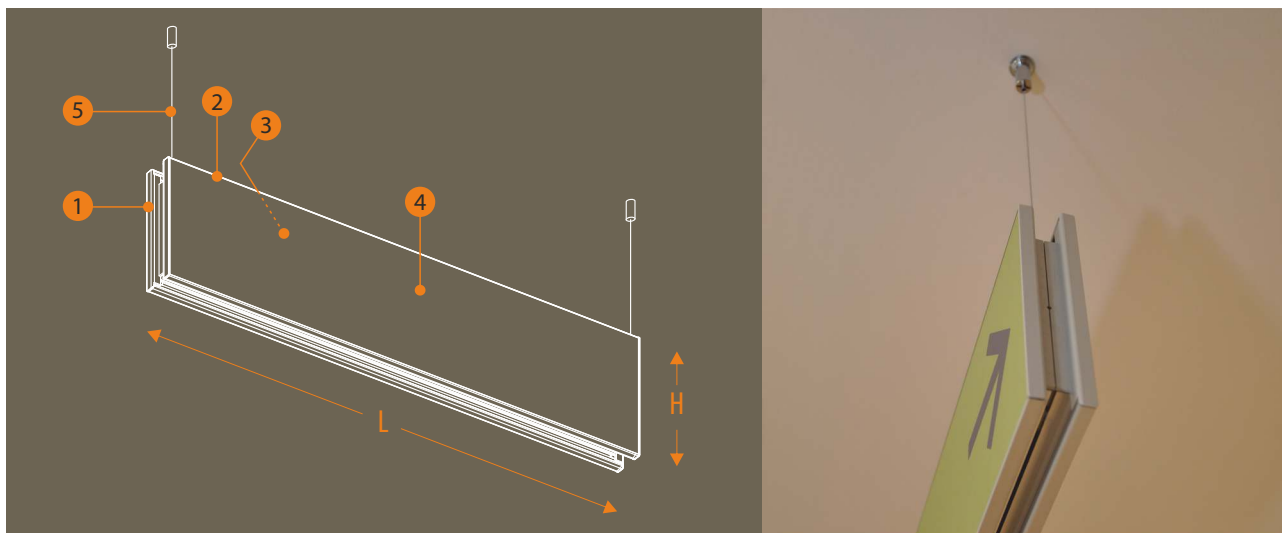

<b>297</b>	EL4.S7030-NF	EL4.S10530-NF	EL4.S12530-NF	EL4.S15030-NF	<input checked="" type="checkbox"/>
<b>210</b>	EL4.S7021-NF	EL4.S10521-NF	EL4.S12521-NF	EL4.S15021-NF	<input checked="" type="checkbox"/>
<b>148</b>	EL4.S7015-NF	EL4.S10515-NF	EL4.S12515-NF	EL4.S15015-NF	<input checked="" type="checkbox"/>
<b>105</b>	EL4.S7010-NF	EL4.S10510-NF	EL4.S12510-NF	EL4.S15010-NF	<input checked="" type="checkbox"/>

**H**

**L**      **700**      **1050**      **1250**      **1500**

Special lenght on demand  
(no more than 2100 mm)  
L personalizzata (max 2100 mm)

Dimensions refer to panelling size

Le dimensioni si riferiscono alle dimensioni della pannellatura

		mill finish grezzo	white RAL 9016 bianco RAL 9016	silver RAL 9006 silver RAL 9006	silver anodized anodizzato silver
<b>1</b>	Plastic end caps: polycarbonate + abs (life-blend) <i>Terminali in plastica: policarbonato + ABS (Life-blend)</i>	<input checked="" type="checkbox"/>	<input type="checkbox"/>	<input checked="" type="checkbox"/>	<input checked="" type="checkbox"/>
<b>2</b>	Aluminium side profiles (fixed) <i>Profili laterali fissi in alluminio</i>	<input type="checkbox"/>	<input type="checkbox"/>	<input type="checkbox"/>	<input checked="" type="checkbox"/>
<b>3</b>	Aluminium basic profile (not in sight) <i>Profilo base (non in vista) in alluminio</i>	<input checked="" type="checkbox"/>	<input type="checkbox"/>	<input type="checkbox"/>	<input type="checkbox"/>
<b>4</b>	Aluminium Composite sheet panel (Dibond) th. 2 mm <i>Pannellatura in dibond sp. 2 mm</i>	<input type="checkbox"/>	<input checked="" type="checkbox"/>	<input checked="" type="checkbox"/>	<input type="checkbox"/>
<b>5</b>	Suspension kit composed by: plasticized steel cables, automatic suspending clamps in chromium brass <i>Kit di sospensione composto da: cavi in acciaio plastificato, morsetti a soffitto automatici in ottone cromato</i>	<input type="checkbox"/>	<input type="checkbox"/>	<input type="checkbox"/>	<input type="checkbox"/>

# ELIX NF PROJECTING PLATES TARGHE A BANDIERA

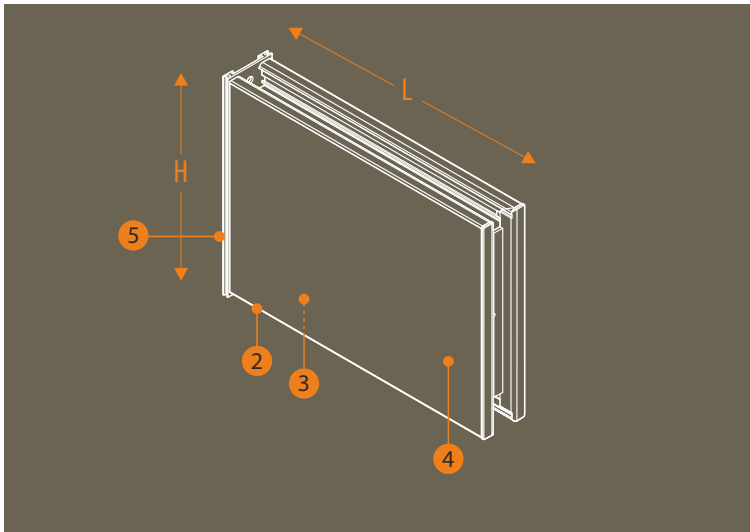

210		A5		A4	
	EL4.B1021-NF	EL4.B1521-NF	EL4.B2121-NF	EL4.B3021-NF	
148	A6		A5		
	EL4.B1015-NF	EL4.B1515-NF	EL4.B2115-NF	EL4.B3015-NF	
105 H		A6			
	EL4.B1010-NF	EL4.B1510-NF	EL4.B2110-NF	EL4.B3010-NF	
L		105	148	210	297

Dimensions refer to panelling size  
Le dimensioni si riferiscono alle dimensioni della pannellatura

The plate is well clipped to end caps and it is also possible to swap one plate with another one. The removal of the plate, in fact, is not a cause of damage neither for end caps nor for the plate itself; this one can be reused and clipped again in another place.

La targa rimane ben solidale ai terminali, tuttavia è possibile interscambiare le targhe. Infatti la rimozione della targa non danneggia né i terminali né la targa stessa, che potrà essere riutilizzata e riagganciata altrove.

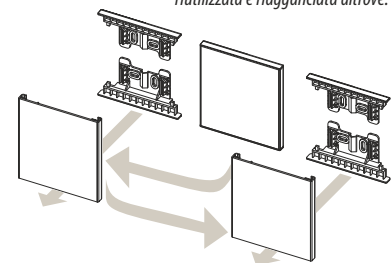

		mill finish grezzo	white RAL 9016 bianco RAL 9016	silver RAL 9006 silver RAL 9006	silver anodized anodizzato silver
1	Plastic end caps: polycarbonate + abs (life-blend) <i>Terminali in plastica: policarbonato + ABS (Life-blend)</i>	<input checked="" type="checkbox"/>	<input type="checkbox"/>	<input checked="" type="checkbox"/>	<input checked="" type="checkbox"/>
2	Aluminium side profiles (fixed) <i>Profili laterali fissi in alluminio</i>	<input type="checkbox"/>	<input type="checkbox"/>	<input type="checkbox"/>	<input checked="" type="checkbox"/>
3	Aluminium basic profile (not in sight) <i>Profilo base (non in vista) in alluminio</i>	<input checked="" type="checkbox"/>	<input type="checkbox"/>	<input type="checkbox"/>	<input type="checkbox"/>
4	Aluminium Composite sheet panel (Dibond) th. 2 mm <i>Pannellatura in dibond sp. 2 mm</i>	<input type="checkbox"/>	<input checked="" type="checkbox"/>	<input checked="" type="checkbox"/>	<input type="checkbox"/>
5	Projecting system coupling in aluminium <i>Supporto a bandiera in alluminio</i>	<input type="checkbox"/>	<input type="checkbox"/>	<input type="checkbox"/>	<input checked="" type="checkbox"/>

# ELIX NF SINGLE POST FREE STANDING for INDOOR

MONOPALO AUTOSTABILE per INTERNO

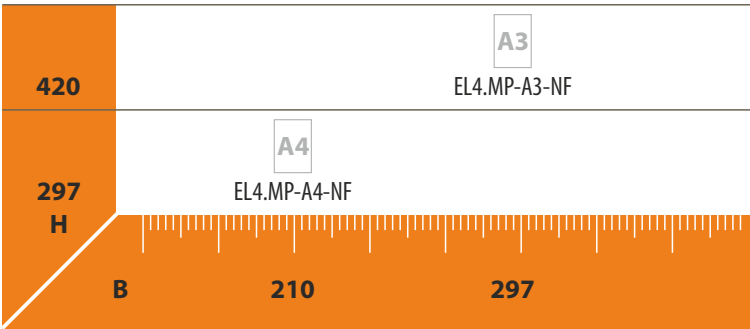
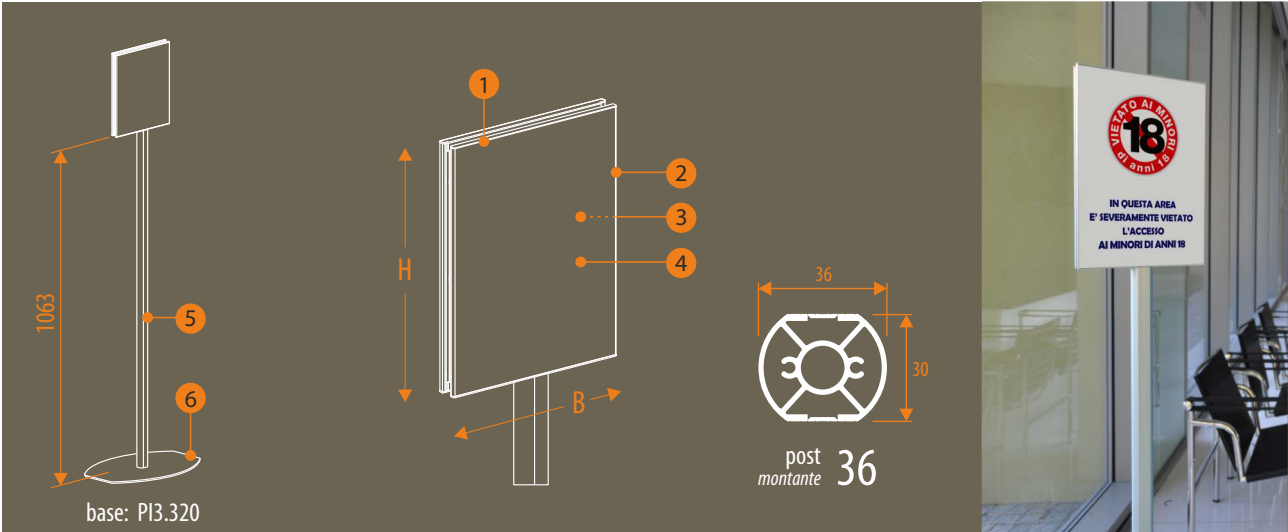

The plate is well clipped to end caps and it is also possible to swap one plate with another one. The removal of the plate, in fact, is not a cause of damage neither for end caps nor for the plate itself; this one can be reused and clipped again in another place.

La targa rimane ben solidale ai terminali, tuttavia è possibile interscambiare le targhe. Infatti la rimozione della targa non danneggia ne i terminali ne la targa stessa, che potrà essere riutilizzata e riagganciata altrove.

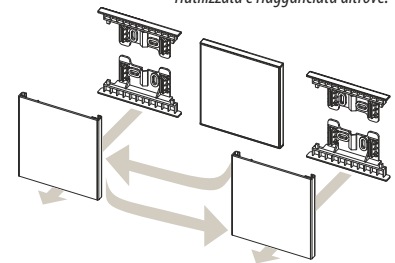

mill finish grezzo	white RAL 9016 bianco RAL 9016	silver RAL 9006 silver RAL 9006	ash grey 007 grigio cenere 007	black 085 nero 085	silver anodized anodizzato silver
<input checked="" type="checkbox"/>	<input type="checkbox"/>	<input checked="" type="checkbox"/>	<input type="checkbox"/>	<input type="checkbox"/>	<input checked="" type="checkbox"/>

1	Plastic end caps: polycarbonate + abs (life-blend) <i>Terminali in plastica: policarbonato + ABS (Life-blend)</i>	<input type="checkbox"/>	<input checked="" type="checkbox"/>	<input type="checkbox"/>	<input type="checkbox"/>	<input checked="" type="checkbox"/>
2	Aluminium side profiles (fixed) <i>Profili laterali fissi in alluminio</i>	<input type="checkbox"/>	<input type="checkbox"/>	<input type="checkbox"/>	<input type="checkbox"/>	<input checked="" type="checkbox"/>
3	Aluminium basic profile (not in sight) <i>Profilo base (non in vista) in alluminio</i>	<input checked="" type="checkbox"/>	<input type="checkbox"/>	<input type="checkbox"/>	<input type="checkbox"/>	<input type="checkbox"/>
4	Aluminium Composite sheet panel (Dibond) th. 2 mm <i>Pannellatura in dibond sp. 2 mm</i>	<input type="checkbox"/>	<input checked="" type="checkbox"/>	<input checked="" type="checkbox"/>	<input type="checkbox"/>	<input type="checkbox"/>
5	Aluminium post <i>Palo in alluminio</i>	<input type="checkbox"/>	<input type="checkbox"/>	<input type="checkbox"/>	<input type="checkbox"/>	<input checked="" type="checkbox"/>
6	Free standing shape base in zincated steel covered with aluminium sheet <i>Base sagomata autostabile in acciaio zincato e rivestita superiormente con alluminio</i>	<input checked="" type="checkbox"/>	<input checked="" type="checkbox"/>	<input checked="" type="checkbox"/>	<input checked="" type="checkbox"/>	<input checked="" type="checkbox"/>

# ELIX M

The modern appeal of the flat lines and their minimalist design make this family of products the ideal solution for a variety of needs. Spin-off from Elix and Elix NF lines, it has been designed to have a magnetic support that can be managed in independent stripes or blocks. An elegant thin frame links this item to the Elix family.

*La modernità delle linee piatte e il design minimalista fanno di questa famiglia di prodotti la soluzione ideale per soddisfare molteplici esigenze. Spin-off delle linee Elix ed Elix NF, nasce per soddisfare la necessità di avere un supporto magnetico gestibile in fasce o blocchi indipendenti gli uni dagli altri. La presenza di una elegante micro cornice perimetrale sottolinea l'appartenenza di questo prodotto alla famiglia Elix.*

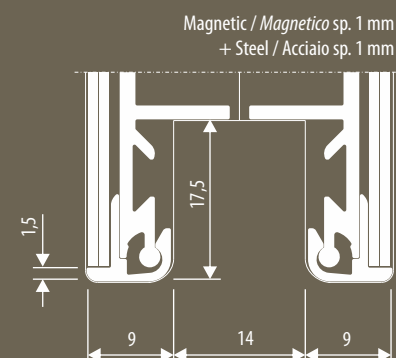
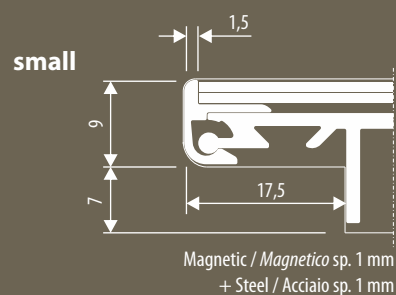
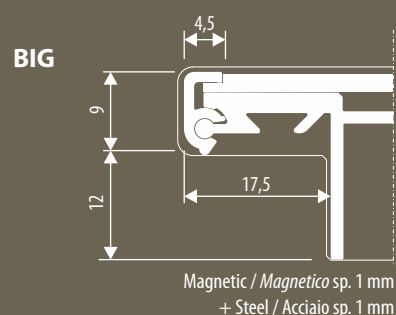

# ELIX M

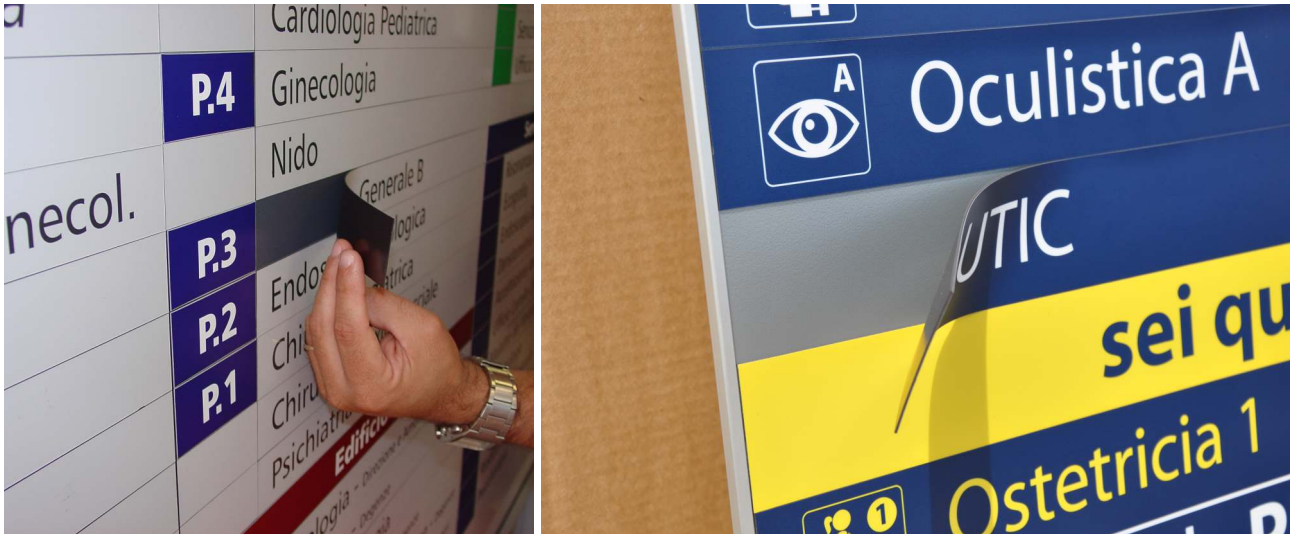

For size and codes see the related type among ELIX plates and. Complete the code adding the suffix **-M**  
 Per dimensioni e codici vedere la relativa tipologia fra le targhe Elix e Elix NF. Completare il codice aggiungendo il suffisso **-M**

## WALL-MOUNTED PLATES (BIG) TARGHE A PARETE (BIG)



### ELIX

WALL-MOUNTED PLATES (BIG)  
TARGHE A PARETE (BIG)

## WALL-MOUNTED PLATES (small) TARGHE A PARETE (small)



### ELIX NF

WALL-MOUNTED PLATES (small)  
TARGHE A PARETE (small)

## WALL-MOUNTED PLATES - LONG HORIZONTAL TARGHE A PARETE ORIZZONTALI



### ELIX NF

WALL-MOUNTED PLATES - LONG HORIZONTAL  
TARGHE A PARETE ORIZZONTALI

## SUSPENDED PLATES TARGHE SOSPESE



### ELIX NF

SUSPENDED PLATES  
TARGHE SOSPESE

## PROJECTING PLATES TARGHE A BANDIERA



### ELIX NF

PROJECTING PLATES  
TARGHE A BANDIERA

## SINGLE POST FREE STANDING for INDOOR MONOPALO AUTOSTABILE per INTERNO



### ELIX NF

SINGLE POST FREE STANDING for INDOOR  
MONOPALO AUTOSTABILE per INTERNO