

GRADOMAX

GRADONE/SOGLIA 120-150



LISTINO N. 6
2025

 **IMERITALIA**[®]
ENGINEERING STONE SOLUTIONS

Made in Italy



TÜV
AUSTRIA
EN ISO 9001:2015
No.: 20001210004370



NATURA, QUALITÀ
ED ECCELLENZA
TECNOLOGICA

NATURE, QUALITY
AND TECHNOLOGY
EXCELLENCE



40 anni di ricerca, di innovazione, di sviluppo...

Abbiamo sempre creduto nell'innovazione, guidati da un'ostinata propensione a creare prodotti di qualità.

È per questo che ogni prodotto firmato IMER rappresenta la più compiuta sintesi di evoluzione visiva e tecnologica che si integra armoniosamente in ogni progetto architettonico.

Grazie al talento delle nostre persone, definiamo tendenze di eleganza e qualità con tecnologie all'avanguardia, per garantire prodotti senza tempo e dalle prestazioni eccezionali, attraverso processi produttivi sostenibili.

40 years of research, innovation, and development...

We have always believed in innovation, driven by an unwavering commitment to creating high-quality products.

This is why every IMER product represents the perfect synthesis of visual and technological evolution, seamlessly integrating into any architectural project.

Thanks to the talent of our people, we set trends in elegance and quality with cutting-edge technologies, ensuring timeless products with exceptional performance, all through sustainable manufacturing processes.

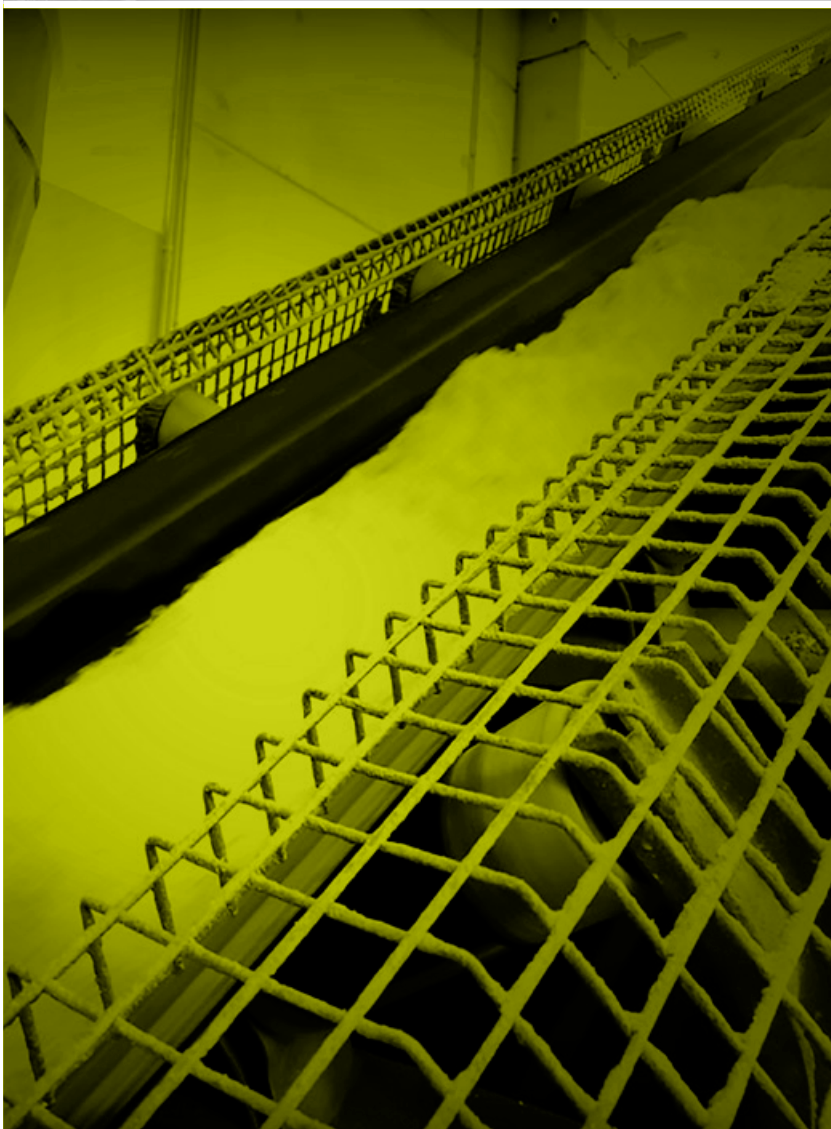



SOSTENIBILITÀ

In IMER ITALIA, la sostenibilità rappresenta un impegno concreto verso un futuro migliore. Utilizziamo materiali di alta qualità e tecnologie avanzate per garantire prodotti duraturi e a basso impatto, ne rispetto dei più rigorosi standard di sostenibilità.

CERTIFICAZIONE CAM (Criteri Ambientali Minimi)

La Certificazione CAM (Criteri Ambientali Minimi), traguardo significativo per la nostra azienda, attesta che i nostri materiali e processi produttivi rispettano i requisiti ambientali definiti dalle normative europee, fondamentali per la realizzazione di progetti edilizi sostenibili. Offriamo prodotti che garantiscono un'elevata sostenibilità durante tutto il ciclo di vita, dalla produzione all'installazione, contribuendo attivamente alla riduzione delle emissioni e degli sprechi.

**Scegliere IMER ITALIA
significa scegliere prodotti certificati e realizzati
con responsabilità, per costruire insieme un
futuro più sostenibile.**

SUSTAINABILITY

At IMER ITALIA, sustainability is a tangible commitment to a better future. We use high-quality materials and advanced technologies to ensure durable, low-impact products that comply with the most stringent sustainability standards.

CAM CERTIFICATION (Minimum Environmental Criteria)

Achieving CAM Certification (Minimum Environmental Criteria) is a significant milestone for our company. It certifies that our materials and production processes meet the environmental requirements set by European regulations, which are essential for the development of sustainable construction projects. Our products are designed to maintain high sustainability standards throughout their entire lifecycle—from production to installation—actively contributing to the reduction of emissions and waste.

Choosing IMER ITALIA means choosing certified products made with responsibility, working together to build a more sustainable future.





2 COLORI 4 FORMATI

2 COLORS
4 SIZES

Biancone
Grigio scuro

MOLTEPLICITÀ DI APPLICAZIONI

Gradoni, soglie, bordo piscina,
davanzali e pensiline

VERSATILE APPLICATIONS

Steps, thresholds, pool edges,
windowsills and canopies

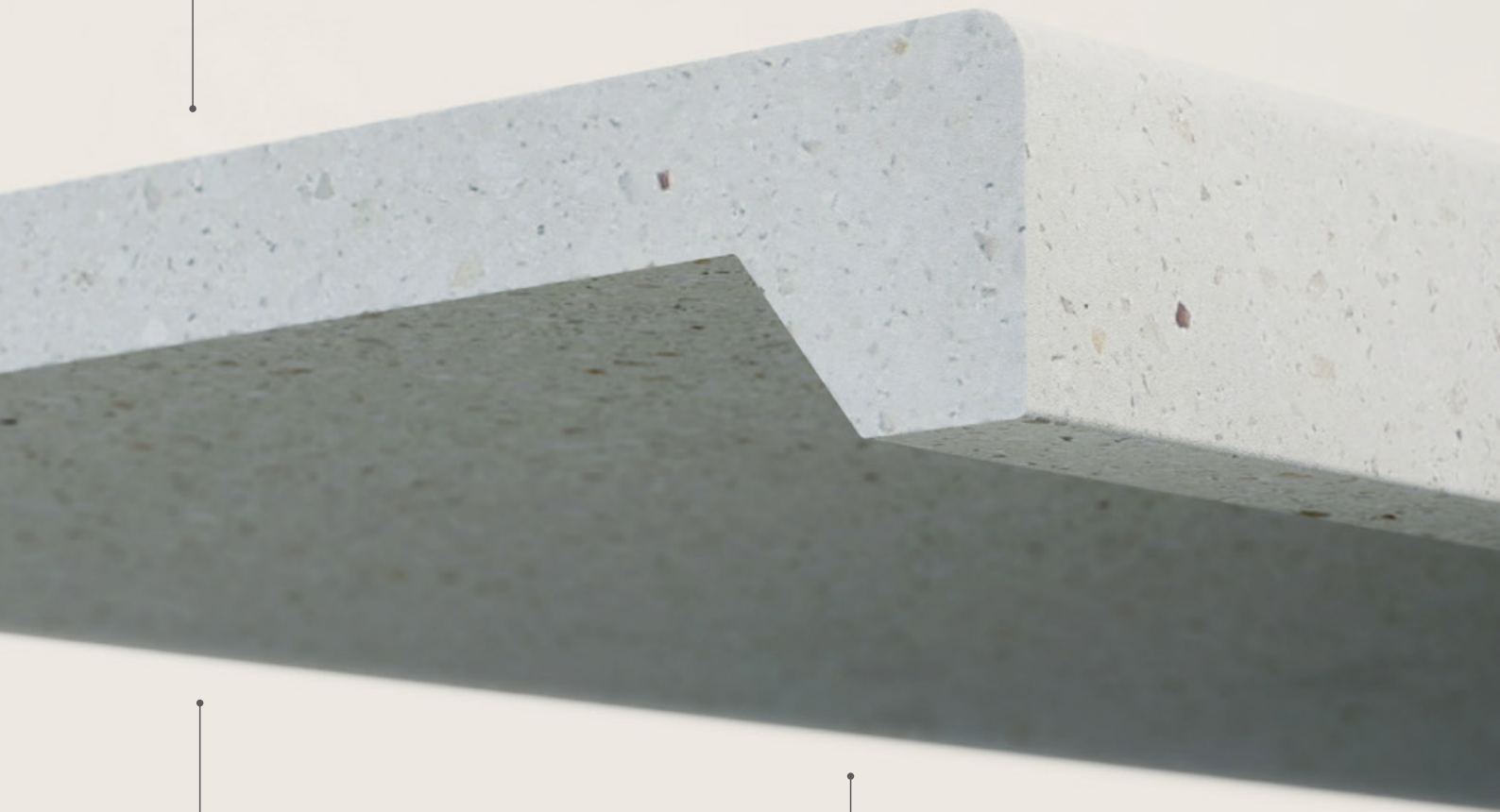

ALTA PERFORMANCE

Resistenza e versatilità
per superfici uniche

HIGH PERFORMANCE

Durability and versatility
for unique surfaces

FINITURA PIETRA

Una nuova espressione
delle pietre calcaree
in versione ipertecnologica

STONE LOOK

A new expression of limestone in a
cutting-edge technological version





GRADOMAX

GRADOMAX

GRADOMAX

GRADOMAX

GRADOMAX



GRADOMAX 120/150

GRADONE - SOGLIA BORDO PISCINA

STEP - THRESHOLD - POOL EDGE



**LUNGHEZZA
120/150 CM**

LENGHT
120/150 CM



**FINITURA
ANTISCIVOLO**

NON-SLIP FINISH



ANTIGELIVO

ANTI-FREEZE



IDROFUGATO

WATER
REPELLENT



SUPER RESISTENTE

SUPER RESISTANT

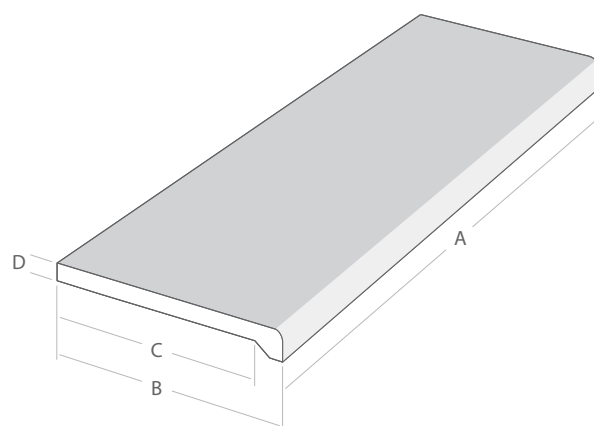
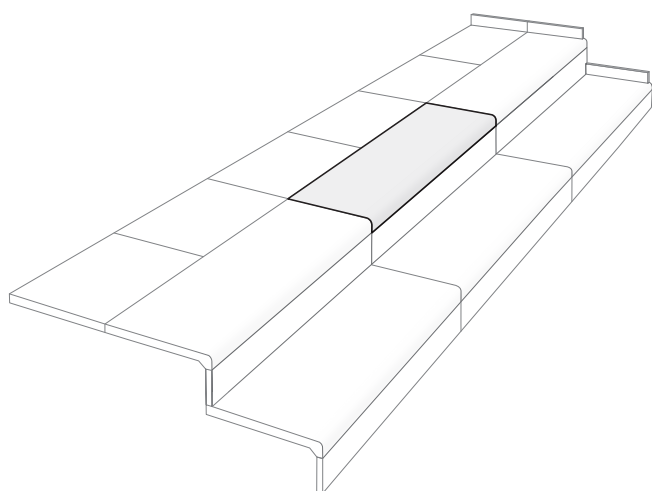

GRADOMAX LEVIGATO GRADOMAX HONED FINISH
In cemento idrofugato Water-repellent concrete

I prezzi si intendono al netto della vigente Iva Vat excluded

Art.	Cod.	Mis. (A)	Mis. est. (B)	Mis. int. (C)	Spessore (D)	Peso per pz.	Pedana	Costo in € per pz	
		Mea	Ext. mea	Int. mea	Depth	Weight per piece	Pallet	Cost in € per pcs	
		Cm	Cm	Cm	Cm	Kg	Pz Pcs	GRIGIO SCURO	BIANCONE
GRADOMAX	GR150/40L	150	40	35	2,5	39,4	28	/	/
GRADOMAX	GR150/35L	150	35	30	2,5	35	28	/	/
GRADOMAX	GR120/40L	120	40	35	2,5	31,5	28	/	/
GRADOMAX	GR120/35L	120	35	30	2,5	28	28	/	/

GRADOMAX BOCCIARDATO SPAZZOLATO GRADOMAX BUSH-HAMMERED AND BRUSHED
In cemento idrofugato Water-repellent concrete

I prezzi si intendono al netto della vigente Iva Vat excluded

Art.	Cod.	Mis. (A)	Mis. est. (B)	Mis. int. (C)	Spessore (D)	Peso per pz.	Pedana	Costo in € per pz	
		Mea	Ext. mea	Int. mea	Depth	Weight per piece	Pallet	Cost in € per pcs	
		Cm	Cm	Cm	Cm	Kg	Pz Pcs	GRIGIO SCURO	BIANCONE
GRADOMAX	GR150/40BS	150	40	35	2,5	39,4	28	/	/
GRADOMAX	GR150/35BS	150	35	30	2,5	35	28	/	/
GRADOMAX	GR120/40BS	120	40	35	2,5	31,5	28	/	/
GRADOMAX	GR120/35BS	120	35	30	2,5	28	28	/	/

Taglio su misura: sovrapprezzo del 30% sul prezzo di listino
 Custom cut: 30% surcharge on the list price

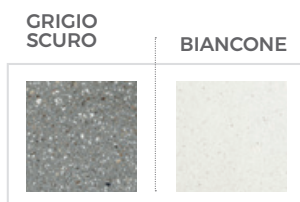

GRADOMAX 120/150

ALZATA

RISER



LUNGHEZZA
120/150 CM

LENGHT
120/150 CM



ANTIGELIVO

ANTI-FREEZE



IDROFUGATO

WATER
REPELLENT



SUPER RESISTENTE

SUPER RESISTANT

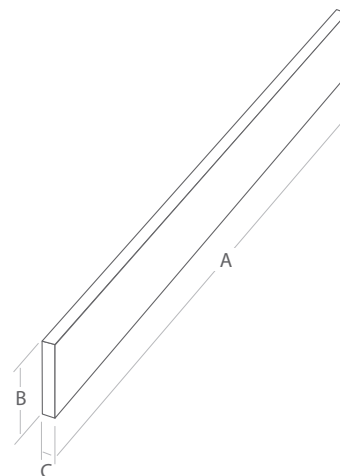
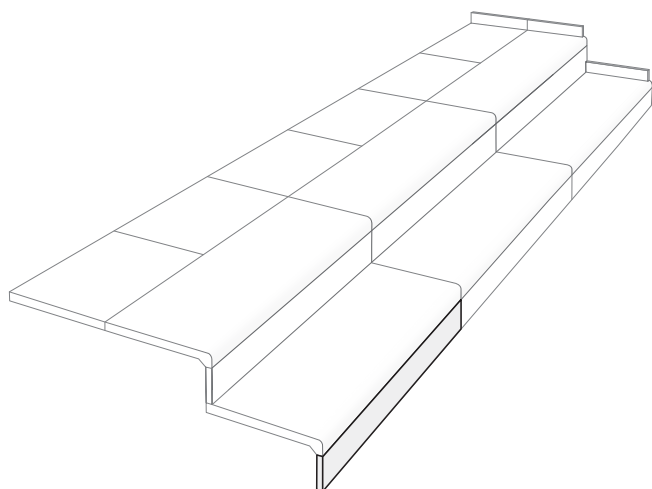

ALZATA GRADOMAX 150 GRADOMAX RISER 150

In cemento idrofugato Water-repellent concrete

I prezzi si intendono al netto della vigente Iva Vat excluded

Art.	Cod.	Mis. (A)	Mis. est. (B)	Spessore (C)	Peso per pz.	Pedana	Costo in € per pz	
		Mea	Ext. mea	Depth	Weight per piece	Pallet	Cost in € per pcs	
		Cm	Cm	Cm	Kg	Pz Pcs	GRIGIO SCURO	BIANCONE
ALZATA GRADOMAX	ALZ/GRD/150	150	12	2,5	11,2	28	/	/
TESTATA ALZATA GRADOMAX	ALZ/GRD/T/150	150	12	2,5	11,2	28	/	/

ALZATA GRADOMAX 120 GRADOMAX RISER 120

In cemento idrofugato Water-repellent concrete

I prezzi si intendono al netto della vigente Iva Vat excluded

Art.	Cod.	Mis. (A)	Mis. est. (B)	Spessore (C)	Peso per pz.	Pedana	Costo in € per pz	
		Mea	Ext. mea	Depth	Weight per piece	Pallet	Cost in € per pcs	
		Cm	Cm	Cm	Kg	Pz Pcs	GRIGIO SCURO	BIANCONE
ALZATA GRADOMAX	ALZ/GRD/120	120	12	2,5	9	28	/	/
TESTATA ALZATA GRADOMAX	ALZ/GRD/T/120	120	12	2,5	9	28	/	/

Taglio su misura: sovrapprezzo del 30% sul prezzo di listino
 Custom cut: 30% surcharge on the list price

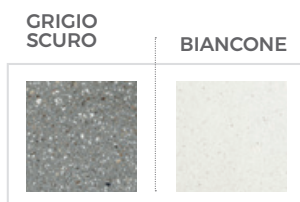

GRADOMAX 120/150

TESTATA BIFACCIALE

DOUBLE-SIDED END PIECE



LUNGHEZZA
120/150 CM

LENGHT
120/150 CM



FINITURA
ANTISCIVOLO

NON-SLIP FINISH



ANTIGELIVO

ANTI-FREEZE



IDROFUGATO

WATER
REPELLENT



SUPER RESISTENTE

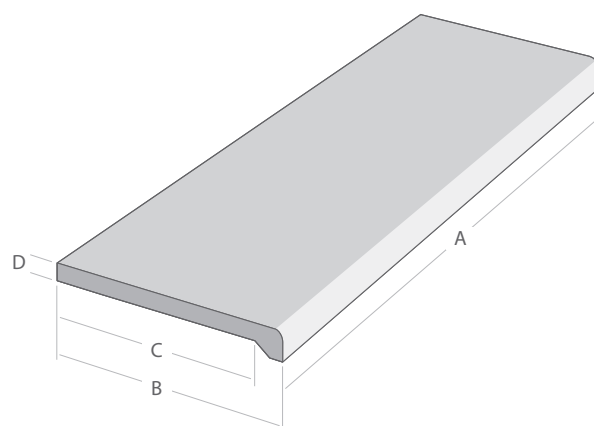
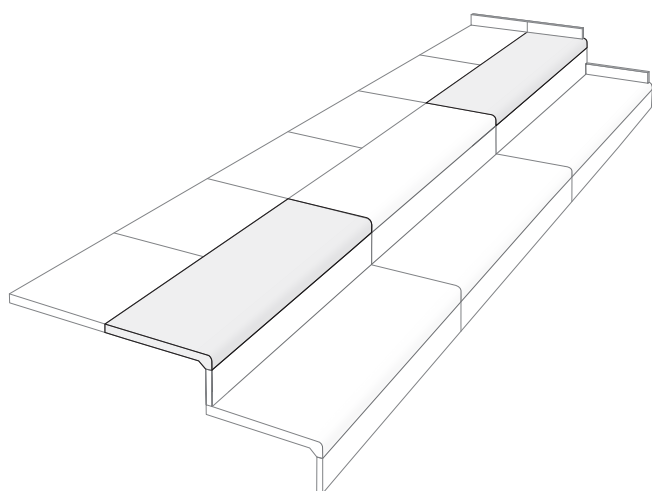

SUPER RESISTANT



TESTATA BIFACCIALE GRADOMAX LEVIGATA GRADOMAX HONED FINISH DOUBLE-SIDED END PIECE

In cemento idrofugato Water-repellent concrete



I prezzi si intendono al netto della vigente Iva Vat excluded

Art.	Cod.	Mis. (A)	Mis. est. (B)	Mis. int. (C)	Spessore (D)	Peso per pz.	Pedana	Costo in € per pz	
		Mea	Ext. mea	Int. mea	Depth	Weight per piece	Pallet	Cost in € per pcs	
		Cm	Cm	Cm	Cm	Kg	Pz Pcs		
TESTATA BIFACCIALE GRADOMAX	TB150/40L	150	40	37,5	2,5	39,4	28	/	/
TESTATA BIFACCIALE GRADOMAX	TB150/35L	150	35	30	2,5	35	28	/	/
TESTATA BIFACCIALE GRADOMAX	TB120/40L	120	40	37,5	2,5	31,5	28	/	/
TESTATA BIFACCIALE GRADOMAX	TB120/35L	120	35	30	2,5	28	28	/	/

TESTATA BIFACCIALE GRADOMAX BOCCIARDATA SPAZZOLATA GRADOMAX BUSH-HAMMERED AND BRUSHED DOUBLE-SIDED END PIECE

In cemento idrofugato Water-repellent concrete

I prezzi si intendono al netto della vigente Iva Vat excluded

Art.	Cod.	Mis. (A)	Mis. est. (B)	Mis. int. (C)	Spessore (D)	Peso per pz.	Pedana	Costo in € per pz	
		Mea	Ext. mea	Int. mea	Depth	Weight per piece	Pallet	Cost in € per pcs	
		Cm	Cm	Cm	Cm	Kg	Pz Pcs		
TESTATA BIFACCIALE GRADOMAX	TB150/40BS	150	40	37,5	2,5	39,4	28	/	/
TESTATA BIFACCIALE GRADOMAX	TB150/35BS	150	35	30	2,5	35	28	/	/
TESTATA BIFACCIALE GRADOMAX	TB120/40BS	120	40	37,5	2,5	31,5	28	/	/
TESTATA BIFACCIALE GRADOMAX	TB120/35BS	120	35	30	2,5	28	28	/	/

Taglio su misura: sovrapprezzo del 30% sul prezzo di listino
Custom cut: 30% surcharge on the list price

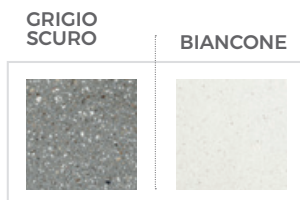

GRADOMAX 120/150

LASTRA PAVIMENTO 2.5

FLOOR SLAB 2.5



**FINITURA
ANTISCIVOLO**

NON-SLIP FINISH



ANTIGELIVO

ANTI-FREEZE



IDROFUGATO

WATER
REPELLENT



SUPER RESISTENTE

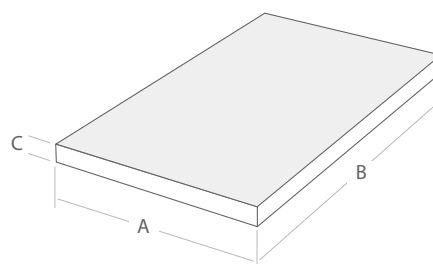
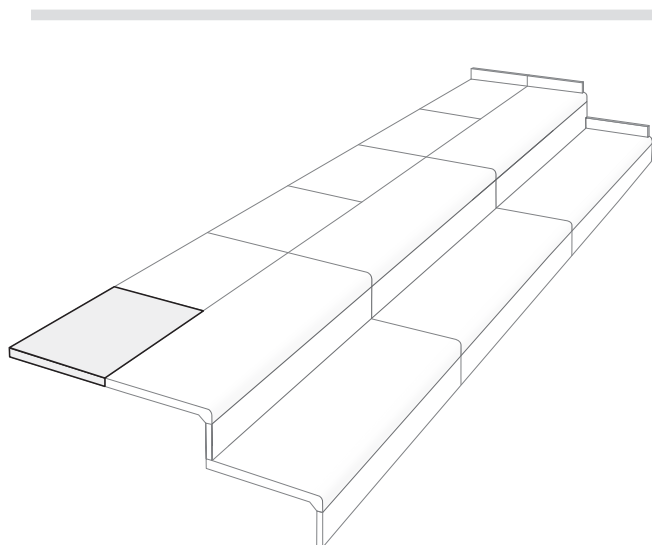

SUPER RESISTANT



LASTRA PAVIMENTO 2.5 LEVIGATA HONED FINISH FLOOR SLAB 2.5

In cemento idrofugato Water-repellent concrete



I prezzi si intendono al netto della vigente Iva Vat excluded

Art.	Cod.	Mis. (A)	Mis. est. (B)	Spessore (C)	Peso per pz.	Pedana Pallet	Costo in € per pz	
		Mea	Ext. mea	Int. mea	Weight per piece		GRIGIO SCURO	BIANCONE
LASTRA PAVIMENTO 2.5	LP60/40L	Cm	Cm	Cm	Kg	Pz Pcs		
		40	60	2,5	12	56	/	/

**LASTRA PAVIMENTO 2.5 BOCCIARDATA SPAZZOLATA
BUSH-HAMMERED AND BRUSHED FLOOR SLAB 2.5**

In cemento idrofugato Water-repellent concrete

I prezzi si intendono al netto della vigente Iva Vat excluded

Art.	Cod.	Mis. (A)	Mis. est. (B)	Spessore (C)	Peso per pz.	Pedana Pallet	Costo in € per pz	
		Mea	Ext. mea	Int. mea	Weight per piece		GRIGIO SCURO	BIANCONE
LASTRA PAVIMENTO 2.5	LP60/40BS	Cm	Cm	Cm	Kg	Pz Pcs		
		40	60	2,5	12	56	/	/

Taglio su misura: sovrapprezzo del 30% sul prezzo di listino
 Custom cut: 30% surcharge on the list price

GRADOMAX 120/150

BATTISCOPA

SKIRTING BOARD



**FINITURA
ANTISCIVOLO**

NON-SLIP FINISH



ANTIGELIVO

ANTI-FREEZE



IDROFUGATO

WATER
REPELLENT



SUPER RESISTENTE

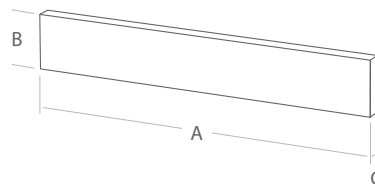
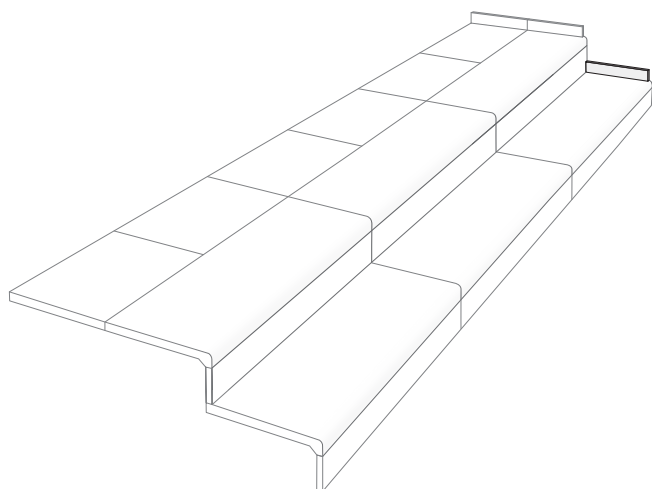

SUPER RESISTANT



BATTISCOPA GRADOMAX LEVIGATO GRADOMAX HONED FINISH SKIRTING BOARD

In cemento idrofugato Water-repellent concrete

I prezzi si intendono al netto della vigente Iva Vat excluded

Art.	Cod.	Mis. (A)	Mis. est. (B)	Spessore (C)	Peso per pz.	Pedana	Costo in € per pz	
		Mea	Ext. mea	Depth	Weight per piece	Pallet	GRIGIO SCURO	BIANCONE
		Cm	Cm	Cm	Kg	Pz Pcs		
BATTISCOPA GRADOMAX	BS40L	40	7	1,5	3	/	/	/

Taglio su misura: sovrapprezzo del 30% sul prezzo di listino
Custom cut: 30% surcharge on the list price



 **IMERITALIA**
ENGINEERING STONE SOLUTIONS

Made in Italy 



REQUISITI GENERALI

Per garantire un'installazione a regola d'arte, è fondamentale verificare le seguenti condizioni preliminari:

- Il sottofondo (massetti, scale o superfici) destinato alla posa dei prodotti GRADOMAX deve essere pulito e asciutto, senza residui di polvere, grassi, cere o vernici.
- Anche gli elementi GRADOMAX devono essere puliti e asciutti prima della posa.
- Se la temperatura dell'ambiente è molto bassa o molto alta, è importante evitare shock termici. Per questo motivo, i prodotti GRADOMAX devono essere acclimatati prima dell'installazione, spostandoli nell'area di posa qualche ora prima del montaggio per uniformare la temperatura.

PAVIMENTI

Per la posa dei pavimenti GRADOMAX, si consiglia l'uso di colle deformabili ed elastiche con presa e idratazione rapide.

L'installazione deve seguire il metodo della doppia spalmatura, garantendo un giunto di dilatazione di 3-5 mm a seconda del formato.

È inoltre essenziale mantenere giunti di dilatazione lungo i perimetri e tra diversi materiali.

Si consiglia di evitare il calpestio per 3-4 giorni dopo la posa, al fine di permettere alla colla di indurirsi correttamente.

Seguire sempre le indicazioni del produttore per adesivi e sigillanti.

SCALE

Per garantire un'installazione sicura ed esteticamente gradevole delle scale, si raccomanda di pulire accuratamente il supporto prima della posa, utilizzare adesivi specifici per il fissaggio ed eseguire una posa a spessore con doppia spalmatura per assicurare un'adesione ottimale.

È fondamentale rispettare le indicazioni tecniche del produttore per garantire stabilità e durata nel tempo.

INDICAZIONI POST-POSA

Per evitare danni ai pavimenti e ai rivestimenti appena posati, è importante proteggerli adeguatamente, evitando il calpestio prima che la colla sia completamente asciutta, utilizzando teli protettivi se si svolgono altri lavori nell'area ed effettuando la pulizia iniziale con prodotti adeguati, evitando detergenti aggressivi.

Per la manutenzione quotidiana, si consiglia di utilizzare prodotti neutri e non abrasivi per preservare la bellezza e la durata delle superfici GRADOMAX.

GENERAL REQUIREMENTS

To ensure a high-quality installation, the substrate (screeds, stairs, or surfaces) intended for the installation of GRADOMAX products must be clean and dry, free from dust, grease, waxes, or paints. GRADOMAX elements must also be clean and dry before installation. If the ambient temperature is very low or very high, thermal shocks must be avoided. To prevent this, GRADOMAX products should be acclimatized before installation by placing them in the installation area a few hours in advance to equalize the temperature.

FLOORING

For the installation of GRADOMAX flooring, the use of deformable and elastic adhesives with fast setting and hydration is recommended.

The installation must follow the double-spread method, ensuring an expansion joint of 3-5 mm, depending on the tile size.

It is also essential to maintain expansion joints along the perimeters and between different materials.

To allow the adhesive to cure properly, avoid foot traffic for 3-4 days after installation. Always follow the manufacturer's recommendations for adhesives and sealants.

STAIRS









For a safe and aesthetically pleasing staircase installation, it is recommended to thoroughly clean the substrate before installation, to use specific adhesives for proper fixation and to apply the double-spread method with a thick-bed installation to ensure optimal adhesion.

Adhering to the manufacturer's technical guidelines is essential to ensure long-term stability and durability.

POST-INSTALLATION GUIDELINES

To prevent damage to newly installed floors and coverings, proper protection is crucial to avoid foot traffic until the adhesive has completely dried, to use protective sheets if additional work is being carried out in the area and to perform the initial cleaning with suitable products, avoiding aggressive detergents.

For daily maintenance, use neutral and non-abrasive products to preserve the beauty and longevity of GRADOMAX surfaces.

CARATTERISTICH TECNICHE TECHNICAL DATA		NORMA NORM	TESTATO LGA LGA TESTED
	Resistenza all'abrasione Resistance to Abrasion	< 30 cm ³ / 50 cm ³	Ø 20 cm ³ / 50 cm ³
	Assorbimento d'acqua Water Absorption	M-% < 8	M-% < 5
	Resistenza alla flessione Flexural Strength	N / mm ² > 5	N / mm ² > 8
	Resistenza alla compressione Resistance to Compression	N / mm ² > 30	N / mm ² > 70
	Carico di rottura Breaking load	KN > 2,5	KN > 3,0
	Peso specifico Density	-	2,40 g / cm ³
	Resistenza allo scivolamento Slippage Resistance	> 6° (R9)	> 8°
	Resistenza al fuoco Fire Resistance	A1	A1 non infiammabile <i>fire resistant</i>
	Resistenza al gelo Frost Resistance	-	Klasse 2/B - 3/D



Made in Italy 



IMER srl

Zona Industriale
73024 Maglie (Le) - ITALY

Tel. / Fax +39 0836 423507

Tel. +39 0836 315814

info@imeritalia.it

imeritalia.it

Azienda certificata
UNI EN ISO 9001:2015

