

# 04



E' il chiudiporta Speedy "entry level" che offre un buon prezzo in rapporto alle sue prestazioni.

E' un chiudiporta particolarmente adatto ad installazioni dove è richiesta una minima profondità di scasso. E' stato studiato e realizzato per essere utilizzato in installazioni interne laddove esiste un riscaldamento a pavimento o dove sono presenti rinforzi strutturali nella soletta.

Date le dimensioni ridotte dei suoi componenti ed in particolare del pistone non è consigliabile l'utilizzo in luoghi ad alta frequenza di passaggio.

7 viti garantiscono un bloccaggio efficace all'interno della cassetta a cementare.

Viene fornito in dotazione con un anello di acciaio inossidabile della stessa finitura del coperchio che ne garantisce continuità di finitura.

Mecanica molto affidabile. Rendimenti superiori al 65%.

Una sola forza (predefinita in fabbrica) si adatta perfettamente al 90% delle porte.

Due circuiti d'olio completamente indipendenti per la programmazione delle velocità di chiusura desiderate con due valvole di regolazione. Una da ca. 115° a 15° e l'altra da ca. 15° a 0°.

Il fissaggio del coperchio alla cassetta a cementare con due posizioni predefinite permette di installare il chiudiporta con qualsiasi interesse di rotazione senza dover modificare in cantiere il coperchio.

Blocco corsa di serie a 120°.



This is the Speedy "entry level" door closer that offers an excellent price in relation to its performance.

This door closer is particularly suitable for installations that require a minimum depth of excavation for thin slab applications. It was designed and built to be installed inside where there is underfloor heating or where there are structural reinforcement in the slab.

Due to the small size of its parts, especially the piston, it is not recommended for high traffic areas use.

7 screws guarantee an effective blocking within the cement case.

A stainless steel ring in the same finish of the cover, is supplied to guarantee the cover uniformity finish.

Highly reliable mechanics. Efficiency higher than 65%.

A single strength (pre-set in factory) perfectly suits to 90% of doors.

Two completely independent oil circuits for to program the desired closing speed with two regulating valves. One from about 115° to 15° and the other from about 15° to 0°.

The fixing of the cover to the cement case with two pre-set positions allows the door closer installation without cutting the cover on site.

Back stop standard at 120°.



Es el cierrapuertas Speedy "entry level" que ofrece una excelente relación calidad-precio.

Es un cierrapuertas adaptado especialmente a instalaciones donde se requiera una mínima profundidad para colocar la caja. Ha estado estudiado y realizado con el fin de ser instalado en interiores allí donde existe un sistema de calefacción de suelo o donde haya refuerzos estructurales en el suelo.

Dadas las reducidas dimensiones de sus componentes y en particular del pistón, no es aconsejable su uso en lugares con alta afluencia.

7 tornillos garantizan una eficaz fijación en el interior de la caja a cementar.

Se suministra de serie un pequeño anillo de acero inoxidable del mismo acabado que la tapa que garantiza un perfecto acabado estético.

Mecánica muy fiable. Rendimientos superiores al 65%.

Una sola fuerza (predefinita en fábrica) se adapta perfectamente al 90% de las puertas.

Dos circuitos de aceite totalmente independientes para la programación de la velocidad de cierre deseada con dos válvulas de regulación. Una de aprox. 115° a 15° y la otra de aprox. 15° a 0°.

La fijación de la tapa a la caja a cementar con dos posiciones predefinidas permite instalar el cierrapuertas en cualquier posición de rotación sin necesidad de modificar la tapa en taller.

Bloqueo de la carrera de serie a 120°.



speedy

M68

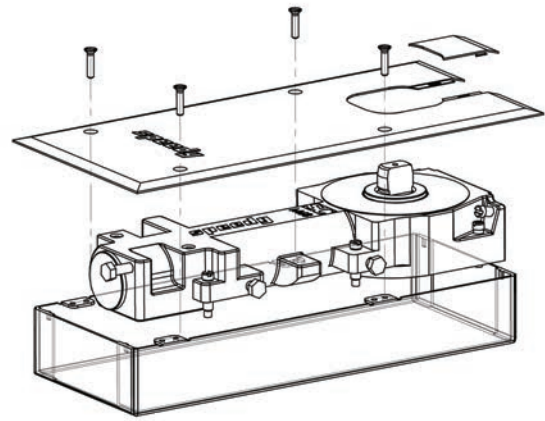

04.M68

## DATI TECNICI

### Technical Data / Datos Técnicos

<p>✓ <b>LARGHEZZA MASSIMA PORTA</b> MAXIMUM DOOR WIDTH ANCHO MÁXIMO DE LA PUERTA</p>	<p>Esterni Exterior Externos</p>	<p>Interni Interior Internos</p>
<p>Forza Rossa Red Strength Fuerza Roja</p>	<p>85 cm</p>	<p>95 cm</p>
<p>✓ <b>PESO DELLA PORTA SOSTENIBILE</b> DOORS WEIGHT UP TO PESO DE LA PUERTA SOSTENIBLE</p>	<p>100 Kg</p>	
<p>✓ <b>DIM. DELLA CASSETTA A CEMENTARE</b> DIM. OF CEMENT CASE DIM. DE LA CAJA A CEMENTAR</p>	<p>110 x 280 x 43</p>	
<p>✓ <b>PESO DELLA CONFEZIONE</b> WEIGHT OF PACKAGE PESO DE LA CONFECCIÓN</p>	<p>5.0 Kg</p>	

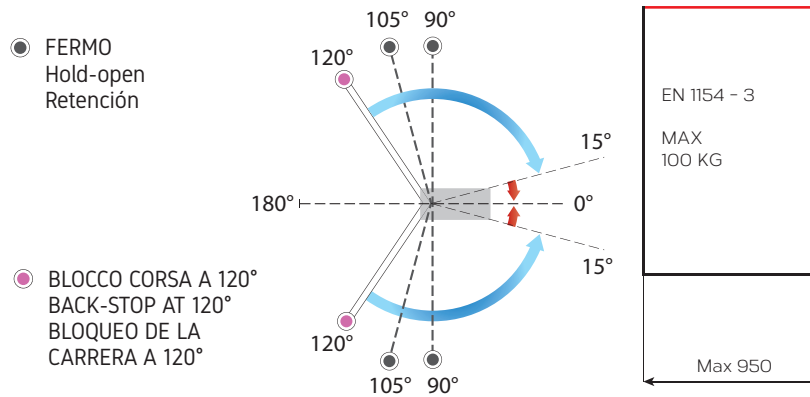
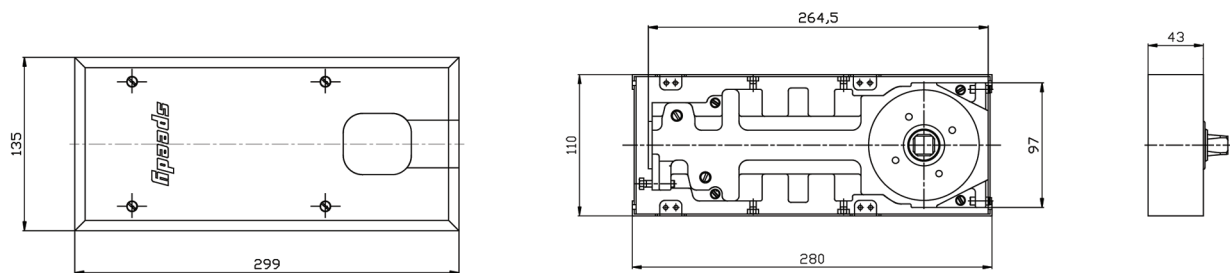

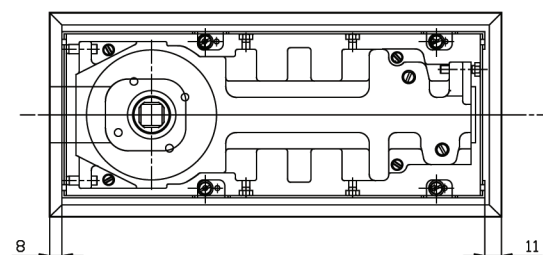
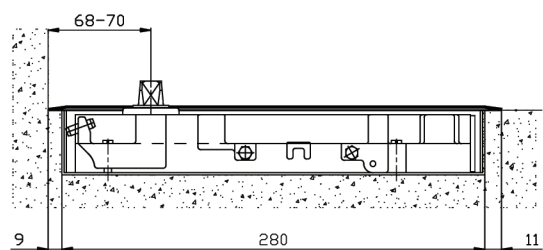
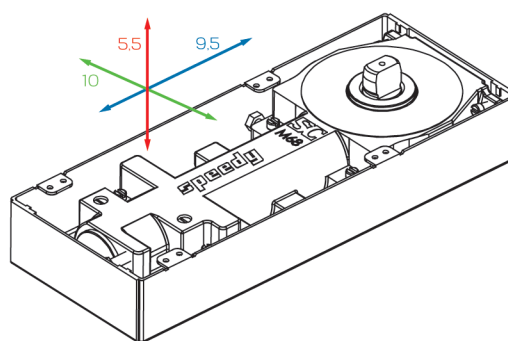
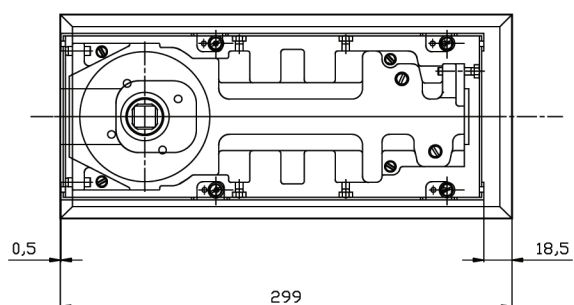
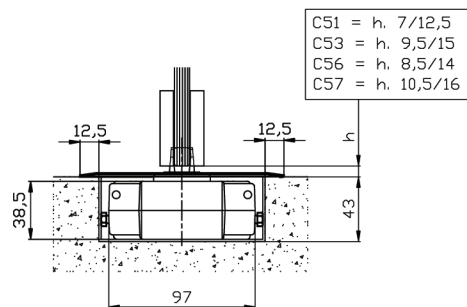
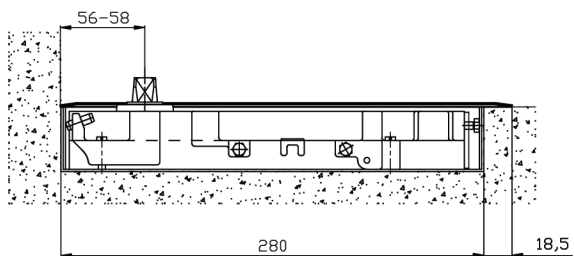

**FINITURE STANDARD**  
Standard finishes/Acabados estándar

Acciaio inox/stainless steel/acero inoxidable

