

TECHNO JUMP



**SARTORI**
AMUSEMENT RIDES

Rides manufacturer since 1957

TECHNICAL SPECIFICATIONS

Park Model / On Trailer

TECHNO JUMP

10

12

14

Base Size:	~ Ø 15 m - 49.2 ft	~ Ø 15 m - 49.2 ft	~ Ø 15 m - 49.2 ft
Height:	~ 5.8 m - 19 ft	~ 5.8 m - 19 ft	~ 5.8 m - 19 ft
Speed:	~ 9 rpm	~ 9 rpm	~ 9 rpm
Vehicles:	10	12	14
Seats/Vehicle:	3 seats/each	3 seats/each	3 seats/each
Seats capacity:	30 seats	36 seats	42 seats
Th. Capacity:	~ 600 passengers/h	~ 750 passengers/h	~ 850 passengers/h
Lighting:	~ 10 kW	~ 11 kW	~ 12 kW
Moving Power:	~ 85 kW	~ 85 kW	~ 100 kW

TECHNICAL SPECIFICATIONS

Structure

DESIGN

The Techno Jump Amusement ride is available both in park model (on self-standing basement) and in carnival model (on semi-trailer) configuration.

TRAILER MODEL

The carnival model version is based on a 13,60Lx2,55Wx4,00H meters semi-trailer with two fixed axles. Each axle has a twin wheels with ABS system and air suspension, Pirelli tires 265 / 19.5 and a hydraulic levelling.

STRUCTURE

The ride is composed by a center rotation hub where the 10/12/14 arms are installed free to move up and down through high performances pneumatic cylinders.

The arms are operated safely by a pneumatic system in conjunction with an electronic system.

The entire set of ride arms movements/jumps are coordinated by a safety PLC and sensors which allows the ride to perform various figure choreographs making the ride very exciting for the rider and attractive for the viewing customer.

TOP VIEW

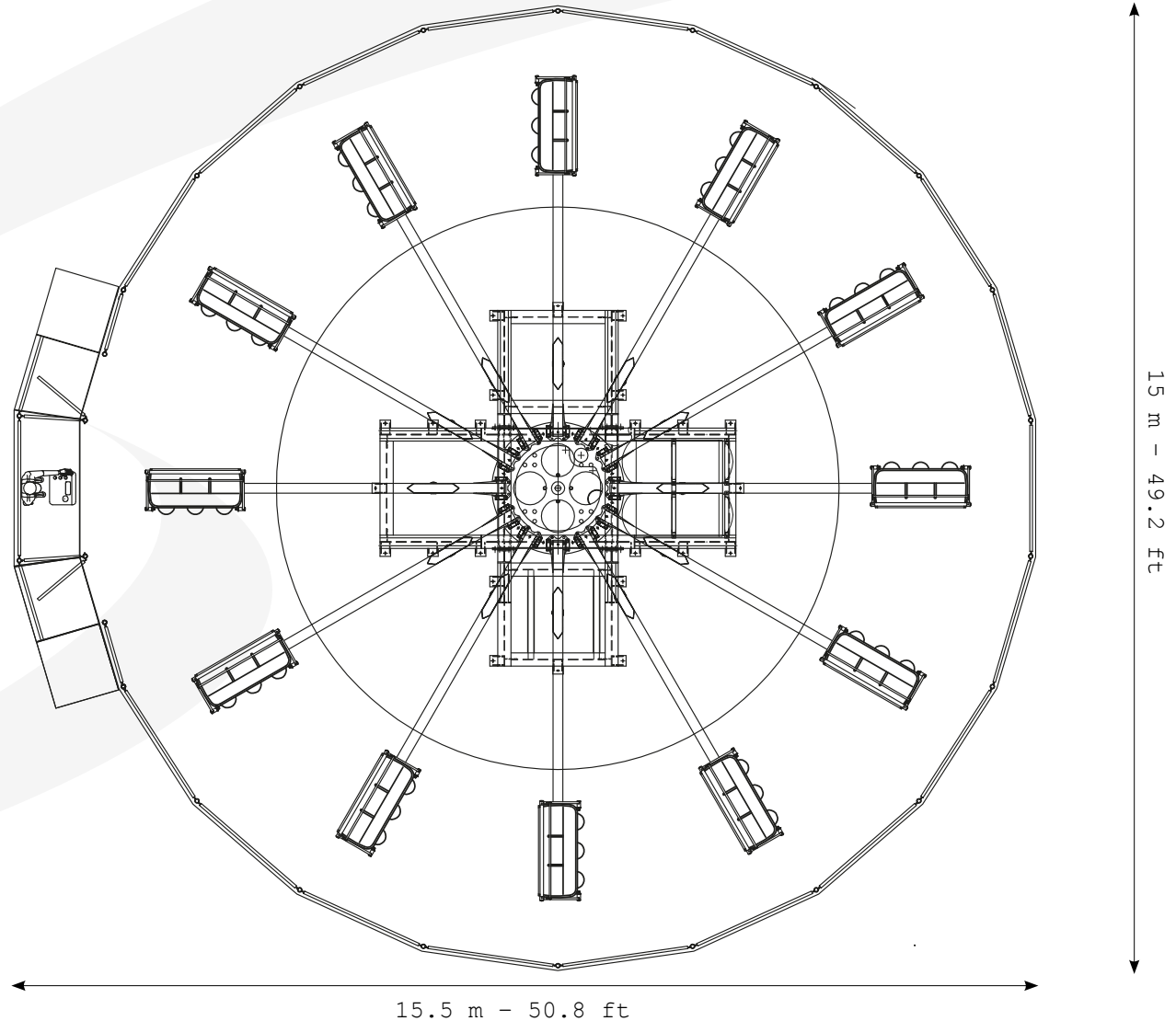

TECHNICAL SPECIFICATIONS

Structure

SIDE VIEW

SPECIFICATION

The ride foot print is the same between the three ride version 10/12/14 arms. Each arms has a 3 seat gondola so the full load capacity is 30/36/42 passengers (depending on the number of arms).

GONDOLAS

The gondolas are decorated and they are all supplied with galvanized iron footboard, aluminum plated; safety locking devices made by safety belts and a lap bars.

OPERATION SYSTEM

The ride is controlled by a safety PLC and can be operated in manual or automatic mode.

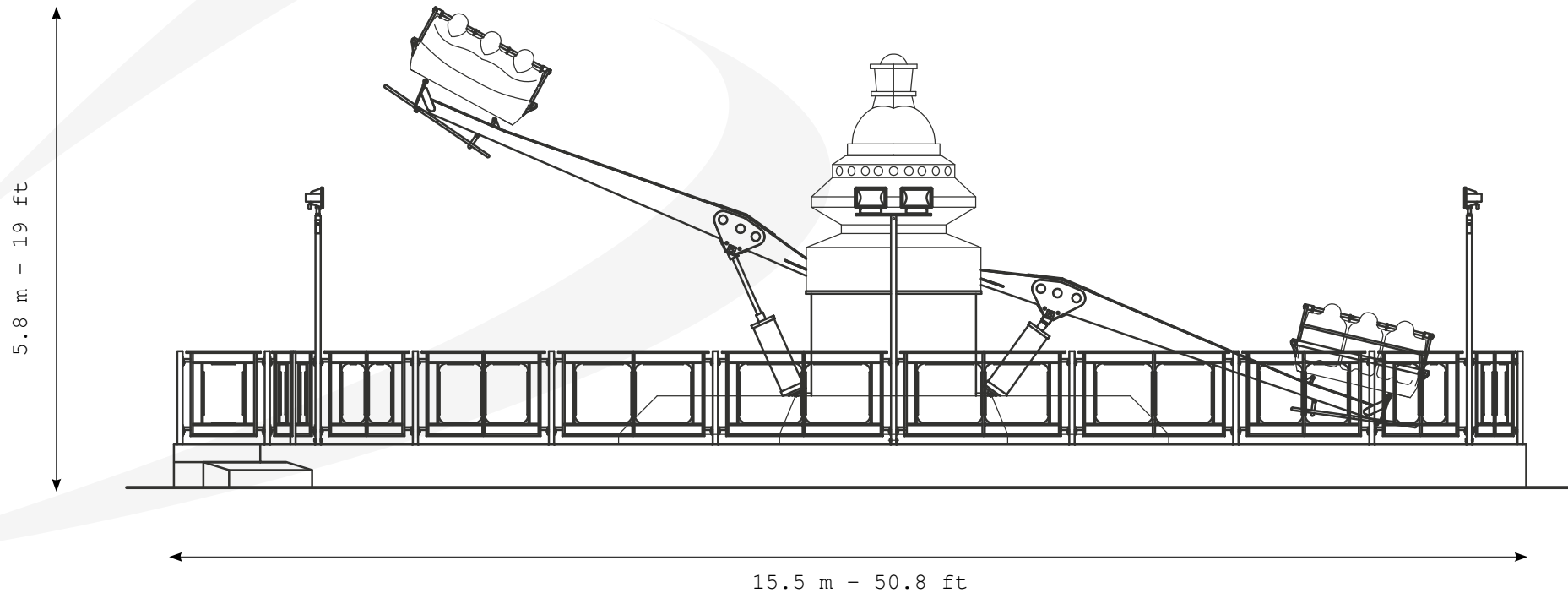

TECHNICAL SPECIFICATIONS

Structure

TRAILER

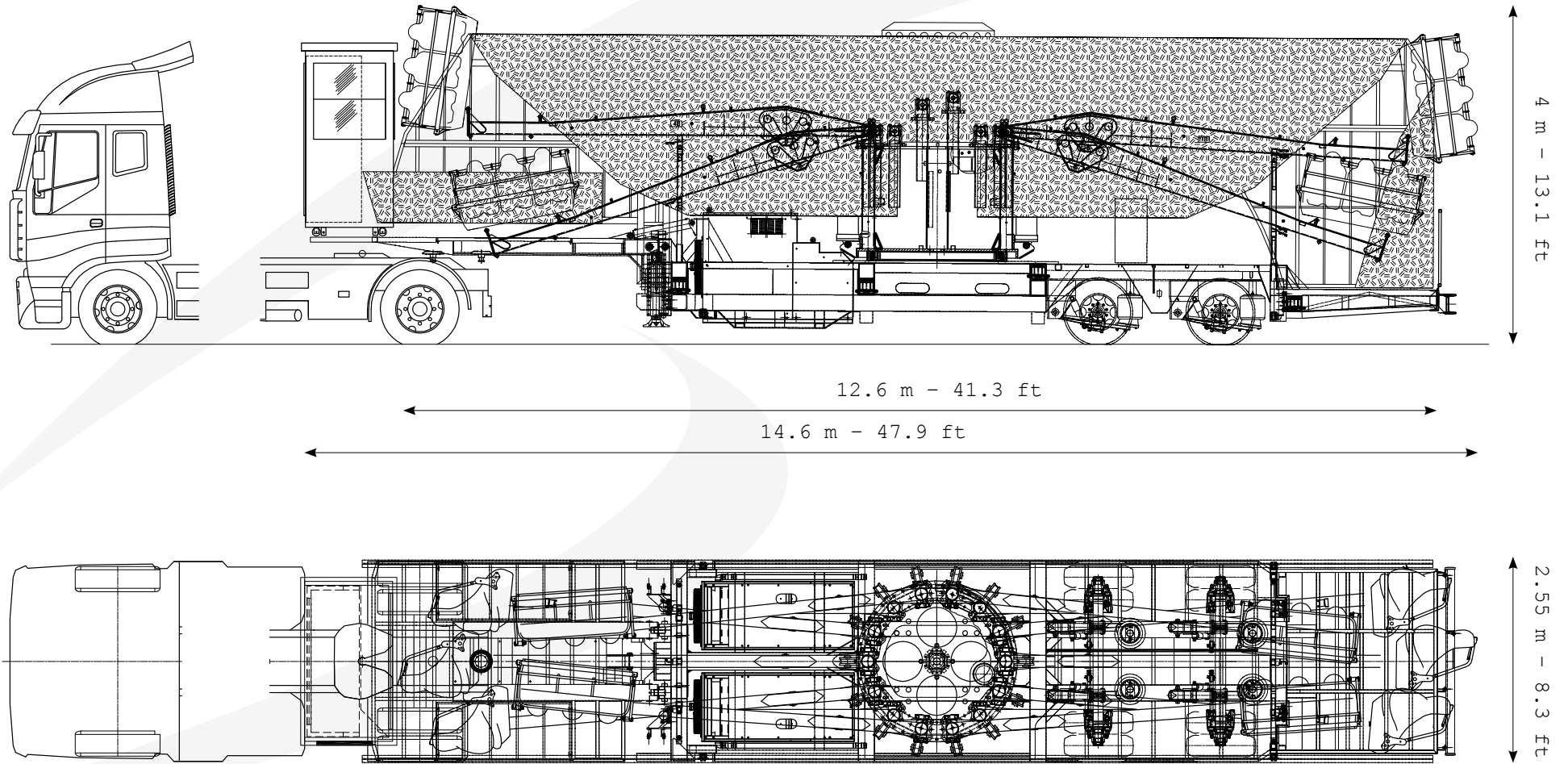

SARTORI
AMUSEMENT RIDES







SARTORI
AMUSEMENT RIDES



