



Tribute to the most famous sound design in the world

Unique hi-fi stereo system, radio & turntable

BRIONVEGA



The story of *“Primo”*

radiofonografo Noce Canaletto



the Story

The “*Primo*”

It is difficult to talk about the *radiofonografo*, (which has become a cult object in many countries of the world), without telling the story of how it was born, and in what form it presented itself for “*Primo*”; with the furniture and wooden loudspeakers, the work of skilled craftsmen, never the same, never “perfect”, always splendid and unique.

“*Primo*” was the first model made with the noble materials of that time, wood and aluminum ..It was designed for an audience of refined and design-conscious consumers.

"The stereophonic *radiofonografo* rr126, modular mobile musical robot of expressive physiognomy, has an exceptional reputation for ease of use, playful formal sobriety and rigor of details..." (Sergio Polano in *Castiglioni*).

the Story

The Selection

Reborn today for the first time, in just **100 units total**, each one signed and numbered.

Each unit is different from the other due to the flame or grain of the wood, and the work of the skilled craftsmen. This is never the same, never "perfect", always splendid and unique.

A careful selection of the "**flames**" of the wood and a maniacal attention to detail combined with a warm and seductive color that only "canaletto walnut" can give, lead this object to become a unique solution for furnishing the most refined environments with music.





the Story

The Function

"Objects must keep company" is one of Achille Castiglioni's most famous phrases, and the *radiofonografo* has been for many years the "companion" of famous musicians such as **David Bowie**.

This confirms the very concept for this unique object that "**it was designed to do company**" and not just perform the function of playing music well.

the Story

The Value

We at **Brionvega** firmly believe in this simple but extraordinary concept that leads us to make only products that last over time, in the function of use and in the beauty of form.

Objects that not only keep company for a whole life, but are past on to following generations as works of art.



radiofonografo
“Primo”



Designers

A. & P.G. Castiglioni



Designers

Achille Castiglioni

Born in Milan in 1918.

As early as 1940 he dedicated himself to testing industrial production with brothers Livio (1911-1979) and Pier Giacomo (1913-1968). After graduating in architecture in 1944, he began research into shapes, techniques and new materials, aimed at developing an integral design process.

Designers

Pier Giacomo Castiglioni

Born in Milan in 1913.

In 1937, he established the “Architecture, Urban Buildings and Research into Industrial Design” practice with his brother Livio. In 1952 Livio left; another brother, Achille joined the practice in 1944. He graduated from the Department of Architecture at Milan Polytechnic in 1937 and co-wrote a libel on the Milan Town Planning Scheme: “Fifty Significant Squares in the Milan of the Future” with the architect Carlo Pagani in 1938.



the Castiglioni

Family, studio & friends



the Castiglioni

The Family

The three brothers **Livio**, **Pier Giacomo** and **Achille** are the sons of Livia Bolla and of the renowned sculptor Giannino Castiglioni from Milan. They are among the fathers of Italian industrial design, co-founders of the ADI (Italian Design Association), winner of 13 "Compasso d'Oro" prizes. Their work includes hundreds of original products. They used to work with Brionvega, giving a crucial contribution to making it a worldwide renowned company.

the Castiglioni

Achille & Pier Giacomo

Their cooperation begins in 1946 and they immediately reach international recognitions and achievements, while contributing to the success of companies such as **Brionvega**, Cassina and Flos. They get several awards, taking the Italian design right on top of the international attention. In 1965 they jointly designed *radiofonografo* which will become a symbol of Italian handcrafting.





the Castiglioni

The Studio

Four rooms and a big mirror in a corner to see the whole studio. One window looking to the Castello Sforzesco appearing in the middle of Sempione park. Inside the studio, which is today open for tours as a **museum**, the visitors can find some brothers' projects, Achille's collection of anonymous objects and many photos of friends and collaborators which dealt with the brothers during the years.

the Castiglioni

The Friends

The brothers' **studio** became soon the landmark for companies and worldwide renowned designers which tightened strong friendship and collaborations with the Castiglioni. Among such relationships is worth remembering Massimo Vignelli who worked as a designer, the great friend and collaborator Max Huber, Vico Magistretti, Bruno Munari, Enzo mari and many other.



the Product

Idea & Project

the Product

The Idea

“That was the important thing, the stereo sound. So we needed to have the two speakers far away”. This is the concept at the base of radiofonografo. **Mobility, dynamism** to an object which used to be static in essence. Together with **minimalistic shape** research, the essence of the project, or the “main engineering component” as the Castiglioni loved to define it.

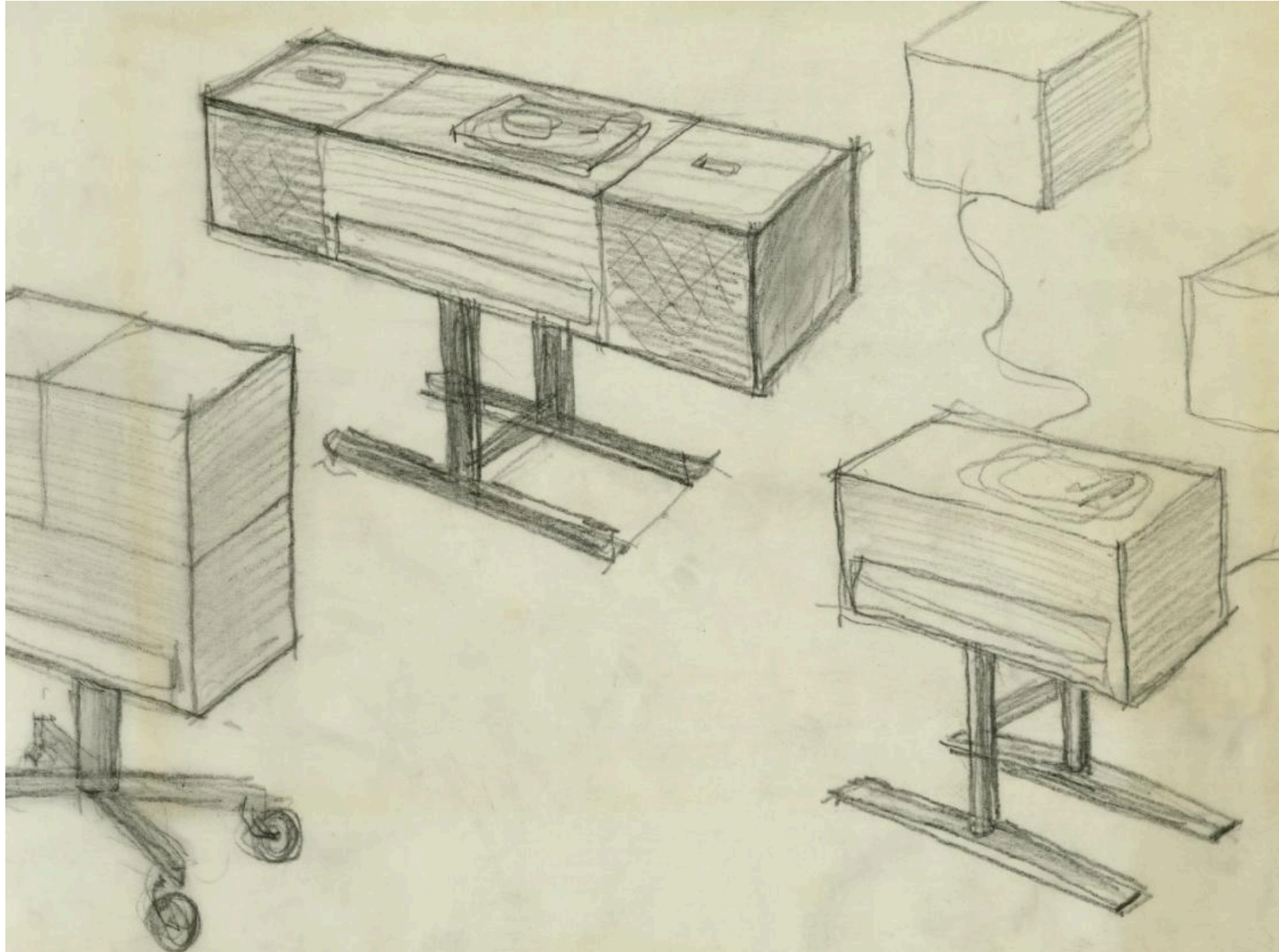

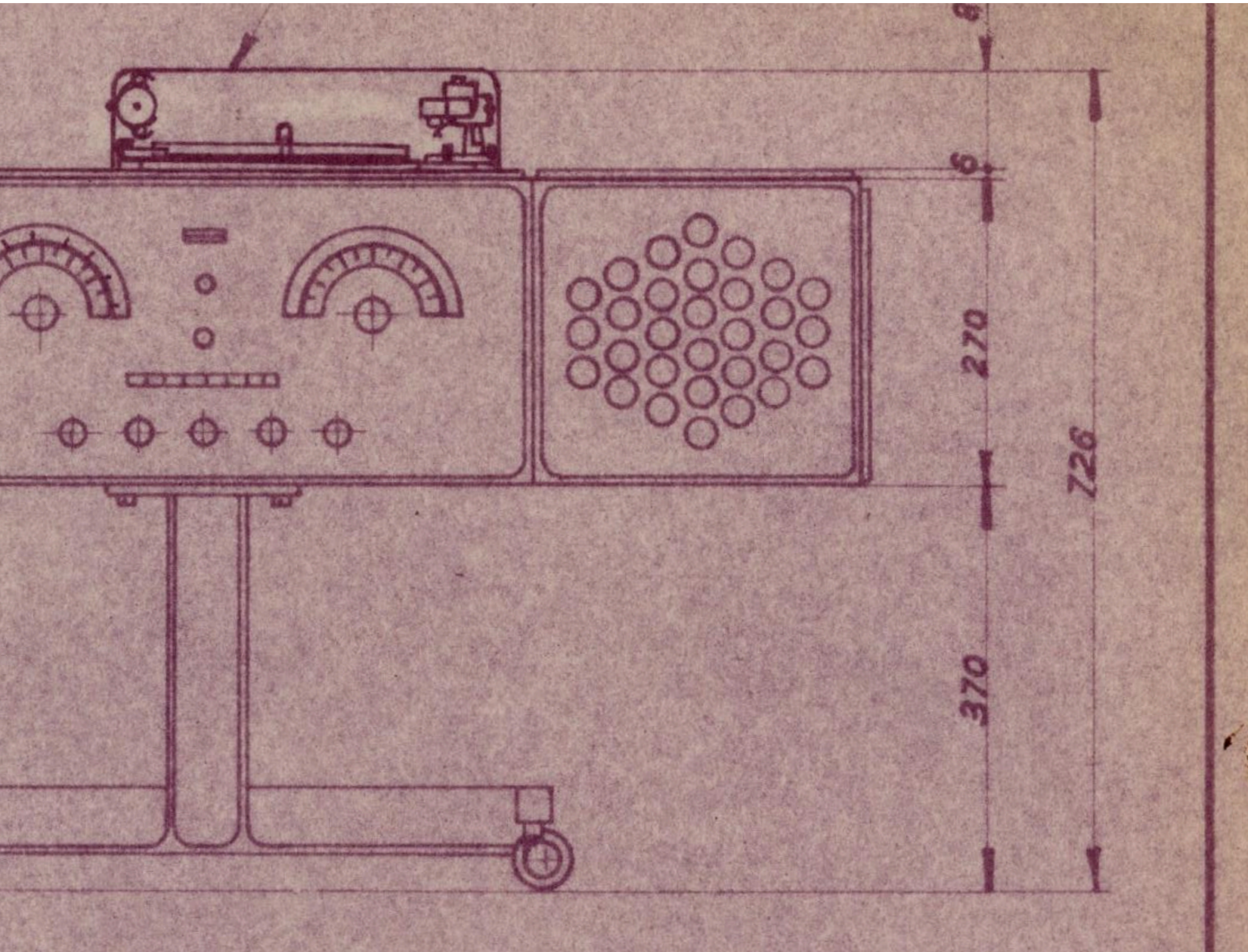

the Product

The Project

Mobility, three different configurations, freely speakers placement, wheels for moving the device to any place in the house. Everything is put to use in delivering the best possible listening experience. Finally the unmistakable “smile” turning it into a friendly object, a musical pet, getting technology closer to the user. Achille itself will define it as “**expressionist object**”.

the Product

The *radiofonografo*

A modular game, a moving object, two speakers with several possible combinations. Over the central body with minimal encumbrance for listening to the radio. On the sides to listen to vinyl records. Detached and placed around the room in order to better appreciate the stereo sound.

Radiofonografo is such, the charm of simplicity.



the Manufacturing

Precision, craftsmanship & quality



the Manufacturing

Precision

Every radiofonografo is an **unique handwork**, but at its origin there is a cutting edge manufacturing process, with buttons and chassis made by CNC milling machines, a stand melted in a single piece from a sand mould and then painted with high technology equipments.

the Manufacturing

Craftsmanship

The capable hands of our artisans turn the precision machineries semifinished products into truly **unique products**. Wood panels sanding, components assembly, stand finishing and silk screen printing are all processes allowing the **italian craftsmanship tradition** to make each radiofonografo unique.

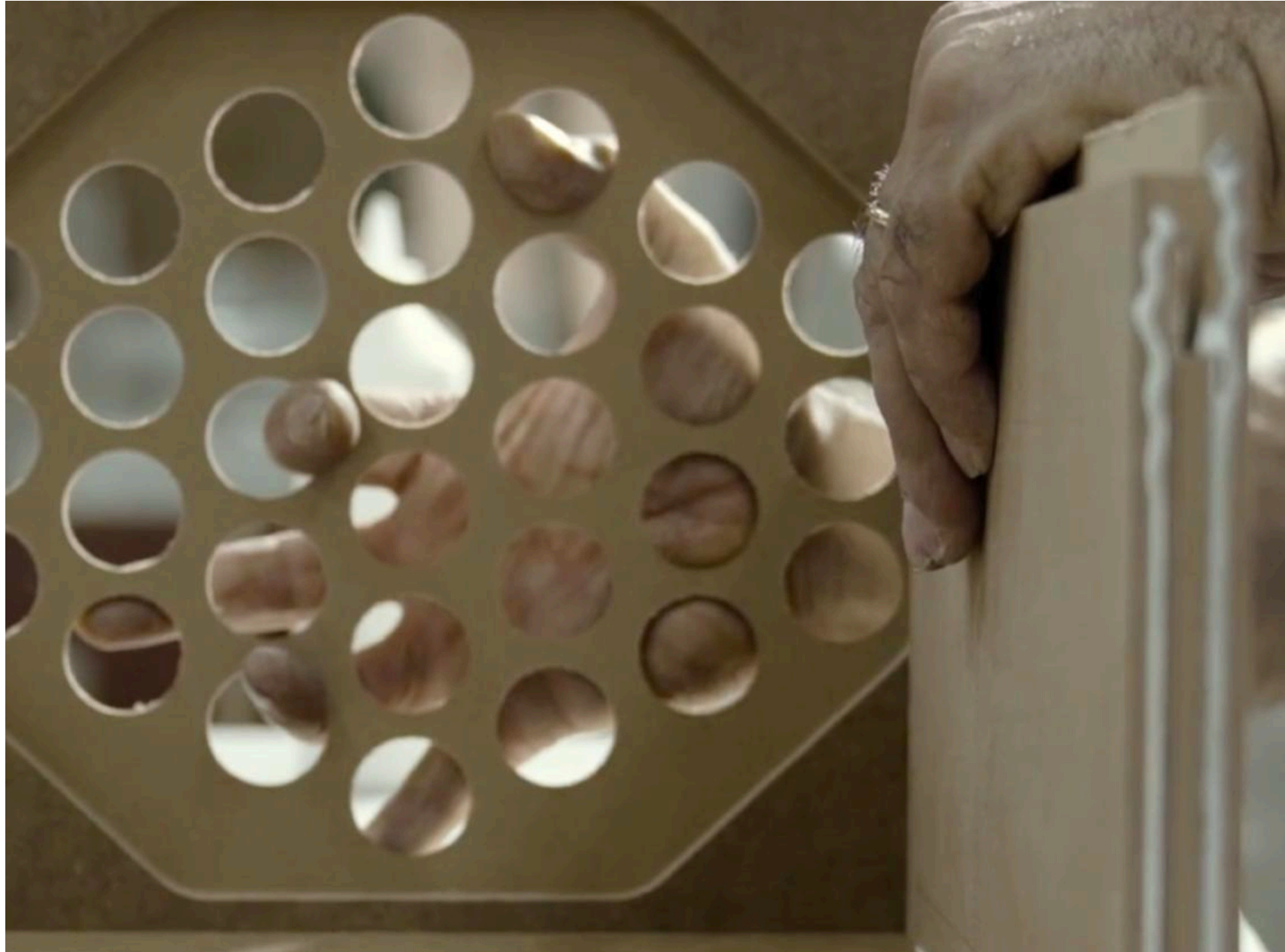



the Manufacturing

Finishing

The typical tobacco colour, hand made stand polishing, CNC milled buttons, Loudspeakers holes hand painted in several layers. The finishing of the many elements composing the *radiofonografo* make for a **timeless quality object**.

the Manufacturing

Quality

Every single element composing radiofonografo undergo a careful quality check in order to ensure the highest quality for each product. From the stand to the speakers, from the main body to the smallest component.

For this reason with each radiofonografo comes a certificate of quality, **authenticity** and **fidelity** to the original project.



radiofonografo
rr226-fo-st

White, orange & red

radiofonografo rr226-fo-st

White - tobacco







radiofonografo rr226-fo-st

Orange - tobacco



radiofonografo rr226-fo-st

Red - tobacco





Technical specifications

radiofonografo rr226-fo-st



radiofonografo rr226-fo-st

Technical Specifications

- *AM/FM Radio*
- *Pro-Ject turntable*
- *125+125W audio amplifier with auto-limitation*
- *2 RCA audio jacks for external sources*
- *1 RCA audio output for connecting to an external amplification system*
- *1 RCA audio output for connecting to an external subwoofer*
- *1 6.3 millimetre preamp audio jack for headphones*
- *Power supply 220v 50Hz (on request 110v 60Hz)*
- *Rests on a cart with forged aluminum wheels*
- *Dimensions: 122 x 30,5 x H 61 cm*
- *Colours: White-tobacco, Orange-tobacco, Red-tobacco & Noce Canaletto*

Technical drawings

radiofonografo rr226-fo-st

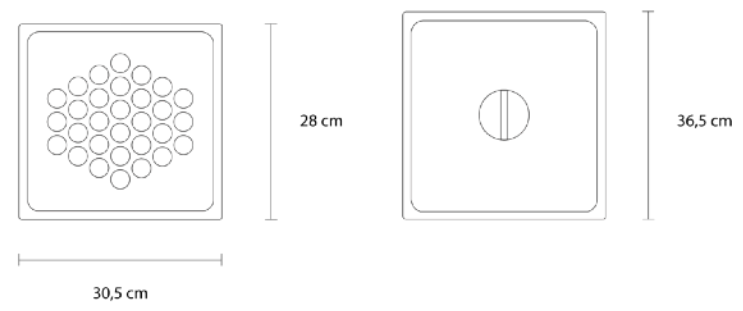
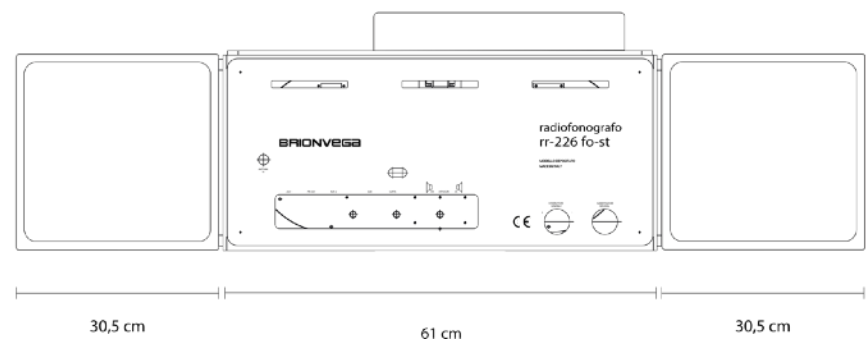
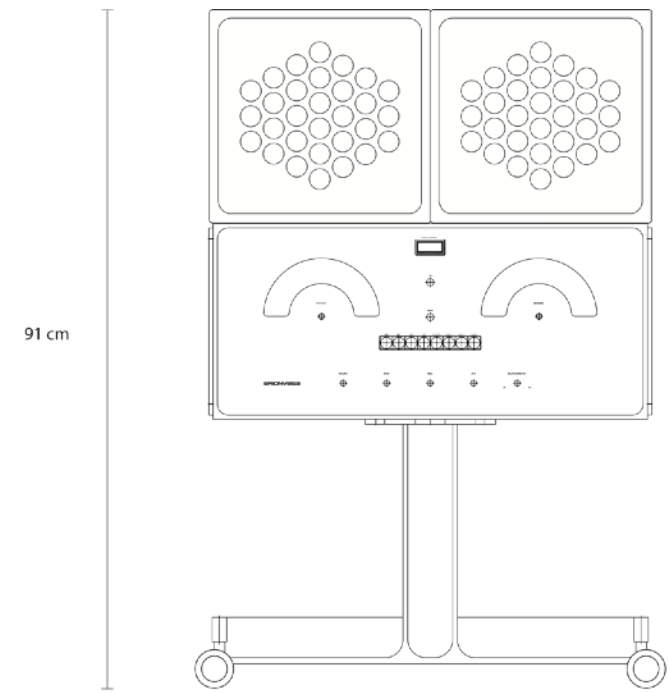
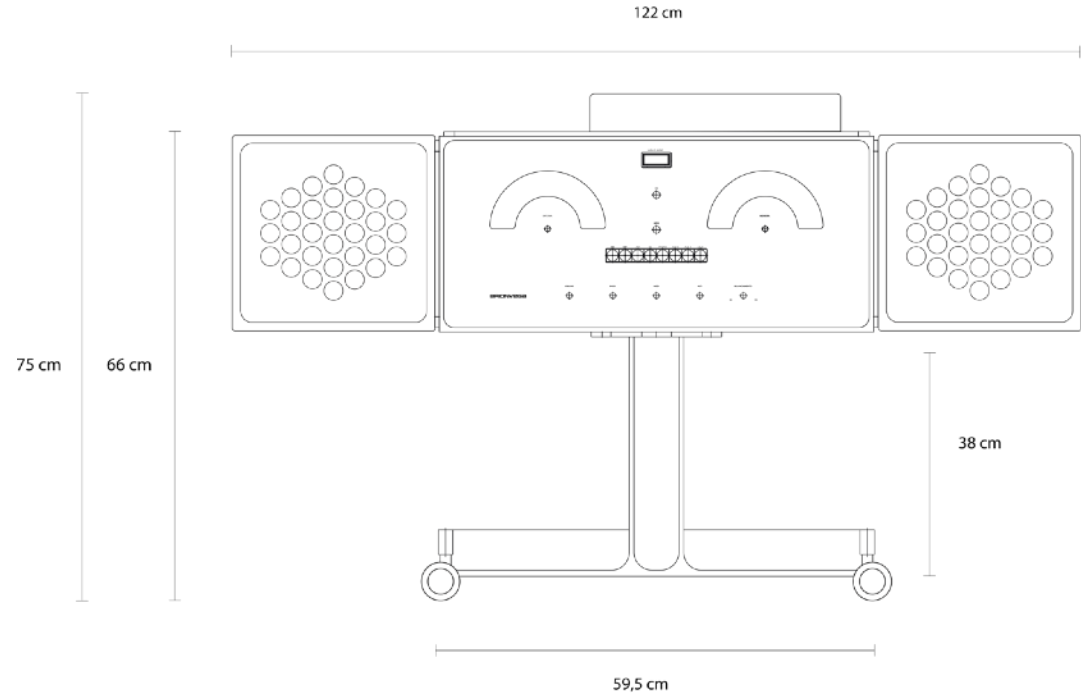

BRIONVEGA

BV2 S.r.l.
MILANO Italy
The BRIONVEGA ART Products Company

Registered office:
Via Marco Ulpio Traiano 33, 20149 Milano (MI)

Operations:
Via Udine 59, 33061 Rivignano (UD)

Mail: info@brionvega.it

Tel. 0434 383283

www.brionvega.it

