

touché A

vassoio | *tray*
Martina Bartoli 2018

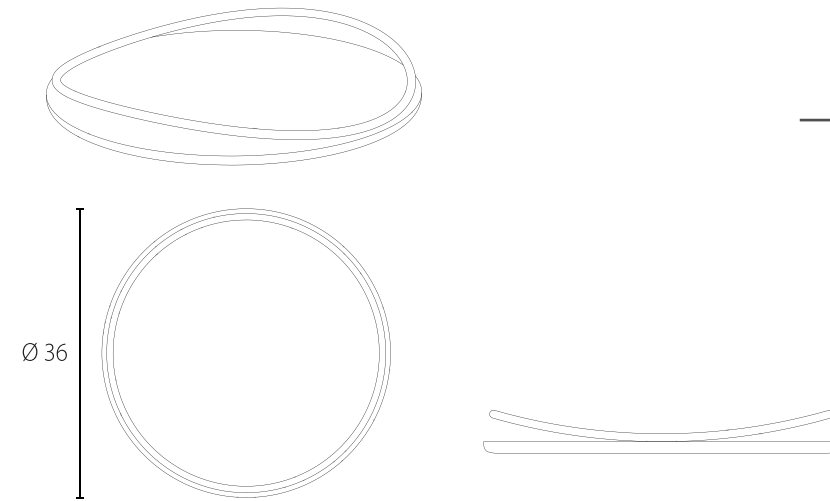

Un leggero tondino in metallo che si appoggia sul piano per poi risollevarsi, sembra sfiorare la superficie con un rapido tocco, definendo i manici dei vassoi Touché.
La forma morbida della base, tonda o ovale, dialoga con il sottile tubolare dando l'impressione di un moto ondulatorio perpetuo, che sembra svanire quando si osservano i vassoi in pianta.

*A light metal rod that rests on the surface and then lifts up seems to touch the surface with a quick tap, defining the handles of Touché trays.
The organic shape of the base, round or oval, combines with the thin tubular giving the impression of a perpetual undulating motion, which seems to vanish when the trays are looked at from above.*



finitura | *finishings:*

M-E.160.001 tortora | *taupe*

M-E.160.003 terracotta | *cotto*

M-E.160.004 bordeaux | *burgundy*

M-E.160.005 verde salvia | *sage green*

M-E.160.006 verde petrolio | *petrol green*

finitura tondino | *handle finish:*

oro 24k opaco | *24k matte gold*

mason
editions

touché B

vassoio | *tray*
Martina Bartoli 2018

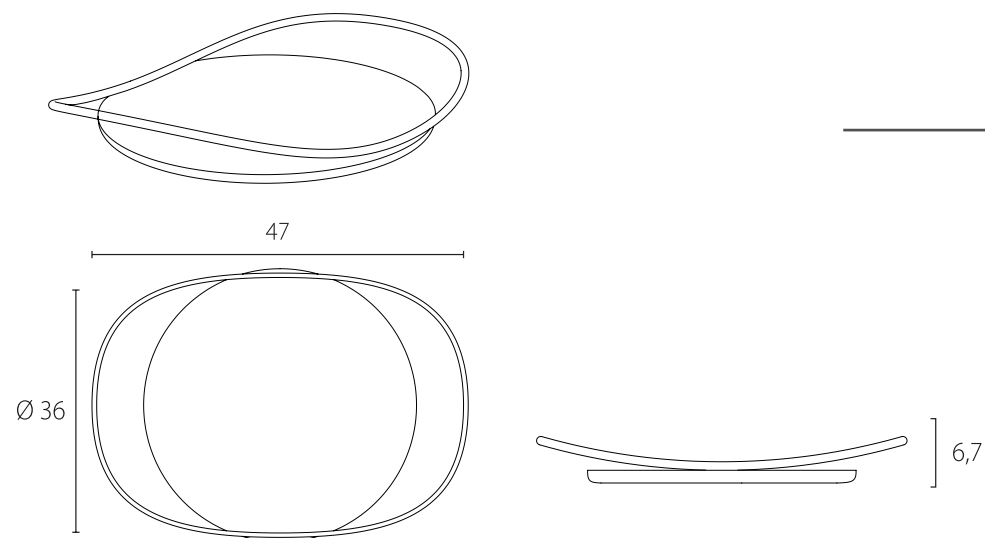

Un leggero tondino in metallo che si appoggia sul piano per poi risollevarsi, sembra sfiorare la superficie con un rapido tocco, definendo i manici dei vassoi Touché.

La forma morbida della base, tonda o ovale, dialoga con il sottile tubolare dando l'impressione di un moto ondulatorio perpetuo, che sembra svanire quando si osservano i vassoi in pianta.

A light metal rod that rests on the surface and then lifts up seems to touch the surface with a quick tap, defining the handles of Touché trays.

The organic shape of the base, round or oval, combines with the thin tubular giving the impression of a perpetual undulating motion, which seems to vanish when the trays are looked at from above.



finitura | *finishings:*

- M-E.161.001 tortora | *taupe*
- M-E.161.003 terracotta | *cotto*
- M-E.161.004 bordeaux | *burgundy*
- M-E.161.005 verde salvia | *sage green*
- M-E.161.006 verde petrolio | *petrol green*

finitura tondino | *handle finish:*

oro 24k opaco | *24k matte gold*

touché C

vassoio | *tray*
Martina Bartoli 2018

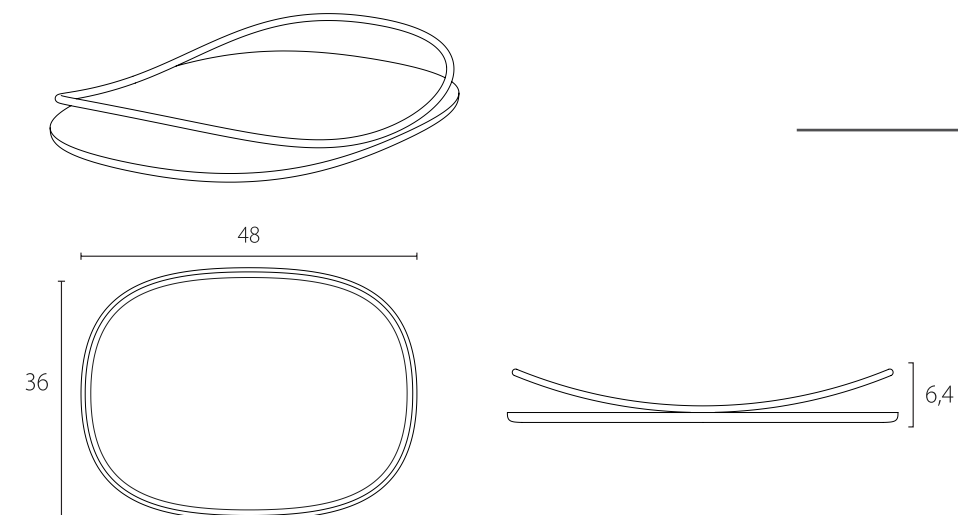

Un leggero tondino in metallo che si appoggia sul piano per poi risollevarsi, sembra sfiorare la superficie con un rapido tocco, definendo i manici dei vassoi Touché.

La forma morbida della base, tonda o ovale, dialoga con il sottile tubolare dando l'impressione di un moto ondulatorio perpetuo, che sembra svanire quando si osservano i vassoi in pianta.

A light metal rod that rests on the surface and then lifts up seems to touch the surface with a quick tap, defining the handles of Touché trays.

The organic shape of the base, round or oval, combines with the thin tubular giving the impression of a perpetual undulating motion, which seems to vanish when the trays are looked at from above.



finitura | *finishings:*

- M-E.162.001 tortora | *taupe*
- M-E.162.003 terracotta | *cotto*
- M-E.162.004 bordeaux | *burgundy*
- M-E.162.005 verde salvia | *sage green*
- M-E.162.006 verde petrolio | *petrol green*

finitura tondino | *handle finish:*

oro 24k opaco | *24k matte gold*

touché D

vassoio | *tray*
Martina Bartoli 2018

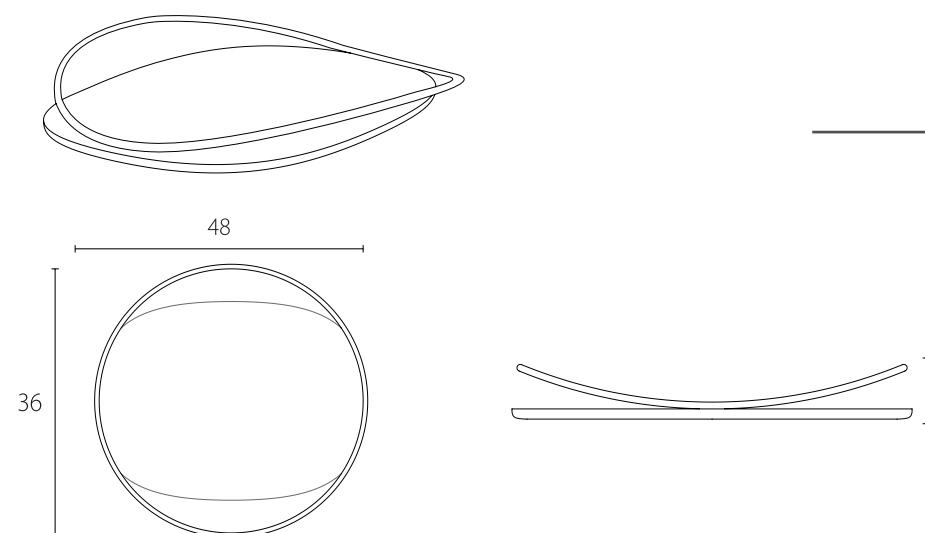

Un leggero tondino in metallo che si appoggia sul piano per poi risollevarsi, sembra sfiorare la superficie con un rapido tocco, definendo i manici dei vassoi Touché.

La forma morbida della base, tonda o ovale, dialoga con il sottile tubolare dando l'impressione di un moto ondulatorio perpetuo, che sembra svanire quando si osservano i vassoi in pianta.

A light metal rod that rests on the surface and then lifts up seems to touch the surface with a quick tap, defining the handles of Touché trays.

The organic shape of the base, round or oval, combines with the thin tubular giving the impression of a perpetual undulating motion, which seems to vanish when the trays are looked at from above.



finitura | *finishings:*

- M-E.163.001 tortora | *taupe*
- M-E.163.003 terracotta | *cotto*
- M-E.163.004 bordeaux | *burgundy*
- M-E.163.005 verde salvia | *sage green*
- M-E.163.006 verde petrolio | *petrol green*

finitura tondino | *handle finish:*

oro 24k opaco | *24k matte gold*

touché E

vassoio | *tray*
Martina Bartoli 2018

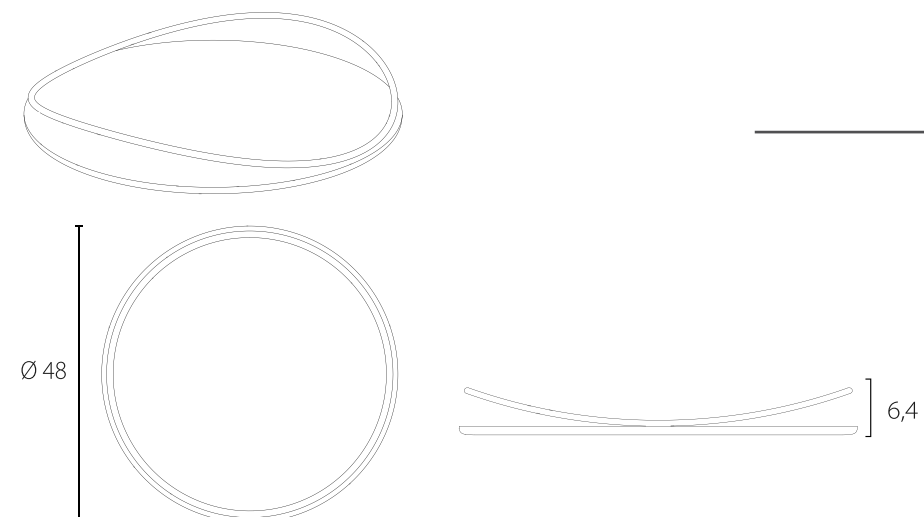

Un leggero tondino in metallo che si appoggia sul piano per poi risollevarsi, sembra sfiorare la superficie con un rapido tocco, definendo i manici dei vassoi Touché.

La forma morbida della base, tonda o ovale, dialoga con il sottile tubolare dando l'impressione di un moto ondulatorio perpetuo, che sembra svanire quando si osservano i vassoi in pianta.

A light metal rod that rests on the surface and then lifts up seems to touch the surface with a quick tap, defining the handles of Touché trays.

The organic shape of the base, round or oval, combines with the thin tubular giving the impression of a perpetual undulating motion, which seems to vanish when the trays are looked at from above.



finitura | *finishings:*

- M-E.164.001 tortora | *taupe*
- M-E.164.003 terracotta | *cotto*
- M-E.164.004 bordeaux | *burgundy*
- M-E.164.005 verde salvia | *sage green*
- M-E.164.006 verde petrolio | *petrol green*

finitura tondino | *handle finish:*

oro 24k opaco | *24k matte gold*