

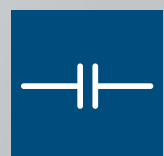

INSTANT SAVING OF ENERGY BILLS AND
ELECTRICAL NETWORKS EFFICIENCY IMPROVEMENT

LV POWER FACTOR CORRECTION SYSTEMS



GENERAL SALES CONDITIONS
downloadable from our website



ABOUT ORTEA



Founded in 1969, ORTEA SpA is a leading company in manufacturing and engineering Power Quality solutions.

Fifty years in the business and ongoing technical research have made of ORTEA SpA a competitive and technologically advanced company.

Close co-operation between design, production and marketing enables to meet the requirements of a constantly growing number of customers.

Beside standard production, ORTEA SpA can be extremely flexible in developing and manufacturing special equipment according to User's specification. All this thanks to the experience gained over many years of applied technological development. Such development includes IT tools that enable the technical staff to elaborate electrical and mechanical designs for each "custom product" on a quick and cost-effective basis.

The ORTEA SpA products are installed and working in a large number of countries, and, thanks to strategically positioned offices and distributors, guarantee rapid and competent support.



QUALITY CERTIFIED



The belief that product quality and Customer satisfaction are the core of a modern organisation, led to the implementation of a certified Company Managing System.

A modern Company that wants to accept the challenge of today's business scenario cannot do so without conforming to standardized organizational criteria.

Customer satisfaction, product quality and responsible occupational practices are the basis on which the Company's activities can be consolidated. ORTEA SpA understood this a long time ago: the first ISO 9001 approval dates back to 1996.

Today ORTEA SpA Integrated Managing System is approved by Lloyd's Register according to the main Standards:

- ISO9001 (Quality management systems).
- ISO14001 (Environmental management systems).
- ISO45001 (Occupational health & safety management systems).

This means that ORTEA SpA can ensure that its performance is optimized in terms of internal process management, commitment towards environmental issues and attention to health & safety at work within the frame of a single Managing System.



ORTEA POWER QUALITY SOLUTIONS

Companies are more and more sensitive to Power Quality issues because they can cause troubles and damages to equipments and processes, up to interrupting the production cycle.

ORTEA SpA, with his brands ORTEA, ICAR and ENERSOLVE, offers a unique range of products and services for Power Quality and Energy Efficiency of low voltage electrical networks: voltage stabilisers, sag compensator, power factor correction systems, transformers and active harmonic filters.

VOLTAGE VARIATION

VOLTAGE STABILISERS



SAGs/DIPs

SAG COMPENSATOR



EXCESSIVE REACTIVE POWER

POWER FACTOR CORRECTION SYSTEMS



UNPROTECTED LOADS

LV TRANSFORMERS



HARMONIC POLLUTION

ACTIVE HARMONIC FILTERS



WASTE OF ENERGY

ENERGY EFFICIENCY
SMART DEVICES



THE 4 REASONS TO HAVE POWER FACTOR CORRECTIONS



Electricity Authorities.

The Electricity Authorities, force companies distributing electricity to apply financial penalties to utilities that have a substantial contractual power and low energy cos phi (generally 0,9). The correct power factor of the electric plant allows you to avoid those penalties, which often are not reflected in the bill, and then are paid by the final user without even realizing it.



Economic convenience.

Economical benefits due to penalties elimination and current reduction, with consequent optimized dimensioning of the components and increased life expectancy.



Energy efficiency.

The power factor correction reduces the “useless” inductive currents required by the loads and that impacts the entire electric network, both in the generation, transmission and distribution stages.

Power factor correction is therefore an important contribution to the energy efficiency of both the user’s electrical system and the electricity grid.



Power Quality.

In many industrial electric plants supplied by MT there is a tension considerably distorted, due often to excessive load of MV/LV transformer.

The correct Power Factor Correction with a consequent load reduction by the transformer allow to bring it back to the operating conditions within the linearity limits, substantially reducing the voltage distortion.

Furthermore the proper Power Factor reduces the presence of harmonic currents.

SERVICES

It is particularly convenient to install an effective power factor correction system, correctly sized

It is essential to monitor the proper functioning because if you do not keep them in perfect working order, they "lose power", and you are likely to pay penalties.

With proper maintenance you can avoid wasting money and unnecessary power dissipation in the electric plant cables and transformers that undergoes premature aging.

It is also important a proper maintenance and use of original spare parts since capacitors, when worn or of poor quality, are likely to burst causing damage to electrical equipment, plant shutdowns due to protection tripping, or even real fire.

We offer a wide range of services to help you in all situations that must be addressed from the choice of the correct power factor correction system, to commissioning, to management, to replacement.

The measurements can be made with an instrument compliant with IEC 61000-4-30 class A, able to check the energy quality according to the indications of the IEC 50160 standard.



Commissioning.



Design and production according to User's specification.



Design and production for complex plants.



Technical training.



Check-up of existing systems.



Make your own measurement and let us know.



Local support.



Energy Quality Analysis.



Revamping solutions, original spare parts.

GLOSSARY

Cos phi

Simplifying, in an electrical system is appointed with phi (ϕ), the phase shift between the voltage and the electric current at the fundamental frequency of the system (50Hz). The cos phi is therefore a dimensionless number between 0 and 1, and varies from moment to moment.

Typically, an industrial electrical system has an inductive cos phi, which value depends on the characteristics of the user plant.

Power factor

In an electrical system means, with power factor, the ratio between the active power and the apparent power. Also the power factor is a dimensionless quantity between 0 and 1, which varies from moment to moment. However, the cos phi and the power factor coincide only in systems devoid of sinusoidal harmonic currents. In a system with harmonic, the power factor is always less than the cos phi.

Monthly average power factor

Electricity bills often show the monthly average power factor, obtained from the ratio between the active power consumed by the user and the apparent power transited the point of delivery. Typically, the average monthly power factor is calculated separately on different time slots.

Isolation level

For a capacitor that complies with IEC 60831-1, the isolation level is indicative of the voltage pulse that can withstand.

Insulation voltage

For a power factor correction system that complies with the IEC 61439-1/2, the isolation voltage is indicative of the maximum voltage that can withstand the entire system.

Nominal voltage of the capacitor U_N

It is the rated voltage of the capacitor, at which its output rated power is calculated.

Maximum operating voltage U_{MAX}

It is the maximum voltage that the capacitor can withstand, for the time indicated by the IEC 60831-1/2.

The following relation applies $U_{MAX} = 1,1 U_N$

Rated operational voltage U_e

It is the rated voltage of the power factor correction system, which guarantees proper use. A capacitor with a rated voltage can have on board capacitors with voltage $U_N > U_e$.

It may never happen otherwise.

Short-circuit current I_{cc}

As indicated in the IEC 61439-1, is the prospective short-circuit current that the cabinet can endure for a specified time. It's a value stated by the manufacturer of the cabinet on the basis of laboratory tests. The short-circuit current of the cabinet can be increased, in case of need, by installing fuses. In this case the declared data must be accompanied by the words "fuse conditioning short-circuit current".

Resonance

In a LV plant, resonance is the amplification phenomenon of harmonic currents generated by one or more non-linear Loads. The LC circuit is responsible for the amplification, consisting of the MV/LV Power Transformer, that feeds that portion of installation, and by the PF improving capacitor bank. To avoid this phenomenon, wherever there is the risk it might happen, the capacitor bank must be equipped with Harmonic Blocking Reactors.

Steps

They are the physical units of power factor bank, each controlled by a dedicated switching device (static switch or contactor). A rack may be constituted by a single step (as typically occurs in detuned bank) or more steps. For example, the MULTIRack HP10 from 150kvar/400V consists of 6 steps: 2 from 15kvar and 4 from 30kvar. It is easily verified by counting the number of contactors present on the front of the drawer. More step can be merged to achieve larger power steps: in these cases they are controlled by the same controller contact of the reactive power regulator.

Electrical steps

It is the internal configurations number which proposes a particular automatic power factor corrector, as a function of the steps (number and power) that has on board. For example, a power factor corrector of 280kvar with steps 40-80-160kvar offers 7 combinations: 40-80-120-160-200-240-280kvar. The greater the number of possible combinations, the better "accuracy" and the flexibility to use the power factor correction bank.

THD (Total Harmonic Distorsion)

For a periodic non-sinusoidal wave, the THD is the ratio between the rms of all harmonic components value and the rms value of the fundamental at 50Hz/60Hz.

THDI_C

It is the maximum THD that a capacitor can withstand, with regard to the current passing through it. It is a characteristic value of each capacitor, indicative of its robustness: much higher is the THDI_C more robust is the capacitor.

The THDI_C is the most significant value to compare different capacitors, together with the maximum temperature of use.

THDI_R

It is the maximum THD bearable by the capacitor relatively to the current that circulates in the plant to be corrected. It is an empirical fact, which is based on the used construction technology and experience of the manufacturer. There is no theoretical link between THDI_R and THDI_C valid for all plants. The THDI_R can also be very different for capacitors with the same THDI_C as made by different manufacturers.

THDV_R

It is the maximum voltage THD on the net and also represents the maximum value bearable by a power factor correction bank with harmonic blocking reactors.

f_D

It is the detuning frequency between inductance and capacitance of a detuned capacitor bank, that is a capacitor bank equipped with harmonic blocking reactors.

The detuning frequency is the most objective parameter for detuned capacitor bank comparison; the lower the detuning frequency is the sounder the capacitor bank is. In particular an 180Hz detuned capacitor bank is sounder and more reliable than another with 189Hz detuning frequency f_D .

As of Ferranti effect, detuned capacitor bank capacitors are exposed to a voltage that is higher than the rated system voltage; for this reason these capacitors are rated for higher voltage compared to the mains voltage.

The according frequency can also be expressed, indirectly, by indicating the detuning factor p%.

POWER FACTOR CORRECTION: QUALITY AND SAFETY

We define safety the absence of dangers for people and things while the good is in use or stored in a warehouse. This means to identify stresses, risks and potential damages and the relevant elimination and to keep them under control so that to reduce the risk to a reasonable level.

Power capacitors and capacitor banks shall NOT be used:

- For uses other than Power Factor Correction and for AC or DC plants.
- As tuned or detuned filters unless specifically approved in written by ORTEA SpA.

General requirement

The capacitors are constructed in accordance with IEC - CEI EN methods, parameters and tests. The low voltage capacitors are assembled with the required protection devices and assembled into banks to give a quality product which will operate safely.

They are not considered as the indication that the capacitors and the power factor correction equipments are suitable for a use in the same conditions of the tests. The user has to verify that the capacitor and power factor correction equipment are of the correct voltage and frequency suitable for values of the network on which they are installed. The user has to verify that the installation of the capacitors and/or the power factor correction equipment is in accordance with the catalogue and the instructions of use. Capacitors and power factor correction equipment must not be exposed to damaging action of chemical substance or to attacks of flora and/or fauna.

Capacitors and power factor correction equipments must be protected against risks of mechanical damaging to which could be exposed during normal working conditions or during the installation.

Capacitors and power factor correction equipments that were mechanically or electrically damaged for any reason during the transport, the storage or the installation must not be used and these that breakdown during use must be immediately removed.

Additional instructions about power factor correction equipments

Definition

Power factor correction equipment means:

- One or more groups of capacitors that can be connected and disconnected on the network automatically or

manually using suitable operating devices (contactors, circuit breakers, load-break switch...).

- Operating devices.
- Control, protection and measure systems.
- Connections.

The equipment could be open or closed inside a metal enclosure.

General requirement

Follow ORTEA instructions in the documentation attached to equipments considering the safe distance, the connection standard criteria, working standards and the instructions for the controls and the maintenance.

Compatibility

It must be paid attention to the electromagnetic interferences with the near by equipments.

Contactors

It is advisable to adopt capacitor duty contactors (category AC6-b) because they are equipped with pre charge resistors that substantially reduce the inrush currents while capacitors are switched on.

The early switching on of these resistors in respect to the closing or the contactor contacts, allows:

- To avoid main contacts melting.
- To avoid capacitor damage.

Recommendations for installation

Fixing and connection

To fix the power factor correction equipments it is advised to use these types of screws:

- SUPERRiphaso with M10 screw.
- MICROmatic and MICROfix wall-mounted with Fischer 8.
- MINImatic wall-mounted and floor-mounted with M8 screw.
- MULTImatic and MINImatic floor-mounted with M12 screw.

The installation of the power factor correction equipment is for indoor application; for different use call ORTEA technical department.

Protection devices

Operating devices (load-break switch) or operation and protection (circuit-breakers if the cables are longer than 3m) must be dimensioned to withstand capacitive currents (about 1.43 times nominal current), the inrush currents, the number of operations and they must be re-strike free.

The capacitors are made of polypropylene that is a flammable material. Even if a fire doesn't begin from capacitors or inside the panel, they could however spread it creating dangerous gasses. If a danger exists from the presence of an explosive or flammable atmosphere, the IEC standard; "Electric equipment with explosion and fire danger", shall be strictly followed.

The protection device must never be opened when the panel is in operation with one or more racks inserted.

Danger for people

When we install power factor correction equipment we must pay attention that the parts which could be exposed to voltage are correctly protected from accidental contacts in accordance with IEC standards.

Before the commissioning verify the tightening of the terminal and of all the bolts is correct.

Protections

Overpressure devices

All the capacitors have an overpressure device which when operated, as in the case of breakdown, disconnects the element from use. This device is not a substitution for the fuses or external circuit-breakers that are specified in our power factor correction equipment.

Limit conditions

The influence of each factor below has not to be considered individually, but in combination and with the influence of other factors.

Voltage

Capacitor and capacitor bank nominal voltage is intended as the design and testing voltage.

The safe and proper use of power factor correction capacitors and capacitor banks, implies that the working voltage is not higher than the nominal voltage.

In special conditions, excluding the installation phases, higher over voltage are allowed as per below table (ref. IEC 60831).

Overvoltage factor (x U _{N eff})	Max duration	Observation
1	Continuous	Highest average value during any period of capacitor energization. For period less than 24h, exceptions apply as indicated below
1,10	8h every 24h	System voltage regulation and fluctuation
1,15	30 min every 24h	System voltage regulation and fluctuation
1,20	5 min	Voltage rise due to light loads
1,30	1 min	

Note: for voltage without harmonics.

The life expectancy of capacitors and power factor correction equipment is greatly reduced when operating in overload conditions.

The choice of the nominal voltage is determined by the following considerations:

- On some networks working voltage could be very different from nominal voltage.
- Power factor correction equipment in parallel could cause an increase of the voltage at the connection point.
- The voltage increases with the presence of harmonics on the network and/or cosφ of in advance.
- The voltage at the capacitor terminals increases when capacitors are in series with reactors for harmonic blocking.
- If the power factor correction equipment is connected to a motor and not sized correctly, when we disconnect it from the network we may have a phenomena caused by the inertia that makes the motor to work as a self-excited generator consequently increasing of the voltage level at the terminals of the equipment.
- The remaining voltage caused by the self-excited after that the equipment has been disconnected from the network is dangerous for the generators.
- If the power factor correction equipment is connected to a motor with a star-delta starting device we have to pay attention to not cause the overvoltage when this device is working.

- All the power factor correction equipments exposed to overvoltage caused by atmospheric lightning must be protected in correct way.

If surge arresters are used they should be placed as close as possible to the equipment.

Working temperature

Working temperature of power factor correction equipment is a fundamental parameter for safe operation. As a consequence it is very important that heat generated is dissipated correctly and that the ventilation is such that the heat losses in the capacitors do not exceed the ambient temperature limits.

The highest workings temperature in normal service conditions between two capacitors is measured at a point 2/3 of the capacitors height and at a distance of 1 cm from them. The capacitor temperature must not exceed the temperature limits showed in the following table.

Symbol	Ambient temperatures [°C]		
	Maximum	Highest mean over any period of:	
		24h	1 year
A	40	30	20
B	45	35	25
C	50	40	30
D	55	45	35

Mechanical Limits

The user has not to expose the equipment to exaggerated mechanical limits of operation. The user has to pay attention to the electrical and geometrical dimensioning of the connections to avoid exceeding the mechanical limits which may be reached by temperature variation.

Other considerations for working safety

Discharge device

Every capacitor must have a discharge device that can discharge it within 3 minutes.

The discharge time is calculated from the starting peak of voltage equal to $\sqrt{2}V_N$ until 75V.

Between the capacitor and the discharge system there shall not be a circuit-breaker, fuses or other sectioning devices. This doesn't relief to short-circuit the capacitor terminals and earth every time it is required to handle the capacitor.

Residual voltage

When the capacitor is placed under tension its residual voltage must not exceed 10% of the rated voltage. This condition is generally satisfied when the power factor correction equipment is calibrated properly, the reactive power controller, reconnection time shall be appropriate to the discharge time.

Enclosure connection

To keep capacitors enclosure at fix voltage and to discharge fault current toward the case itself, they are grounded by connecting to earth the capacitors supporting frame.

Altitude

Power factor correction equipment must not be used above an altitude of 2000m. On the contrary please contact technical assistance.

Particular ambient conditions

Power factor correction equipment are not suitable for the applications in places where there are conditions as follows:

- Fast generation of mould.
- Caustic and saline atmosphere.
- Presence of explosive materials or very flammable.
- Vibrations

For environments with these characteristics: high relative humidity, high concentration of dust and atmospheric pollution, please contact technical assistance.

Maintenance

After the disconnection of the bank, prior to accessing the terminals of the capacitors wait 5 minutes and then shortcircuit the terminals and earth. Periodically make these procedures:

Once every 6 months:

- Cleanliness by blast of air of the internal part of the power factor correction equipment and of the air filter anytime there is a cooling system.
- Visual control.
- Control of the ambient temperature.

Once a year:

- Control of the surfaces condition: painting or other treatments.

- Control of the correct tightening of the screw (this operation must be done before the commissioning).
- Checking the contactors status.
- Checking the capacitors and chokes (if present) status.

If there are concerns about any environmental conditions an appropriate maintenance program must be established (for example in a dusty environment could be necessary to clean using blasts of air more frequently).

Storage and handling

The power factor correction equipment handling must be made carefully avoiding the mechanical stresses and shocks. The equipment in highest cabinet may be hard to handle, because the center of gravity may be very high and decentralized.

Upon receipt of new equipment, make sure that the packaging is not damaged, although mild.

Always make sure that the equipment has not been damaged by transportation: take away the packaging and make a visual inspection with open door. If you discover some damage, write it on the delivery note (carrier copy) the reason for refusal or reserve.

The capacitors and power factor correction awaiting installation storage must be done leaving them in their original packaging, in a covered and dry place.



EXPERIENCE

Founded in 1969, ORTEA SpA has gained experience and know-how that enabled continuous growth and evolution. This never-ending process has allowed the Company to assume a leading role worldwide in designing and manufacturing Power Quality solutions.



RELIABILITY

Thanks also to its long-established Quality System, ORTEA SpA can ensure the production of reliable and long lasting products, each one of them accurately tested.



FLEXIBILITY

In addition to the standard production, the extremely flexible organization of ORTEA SpA is able to develop and manufacture cost-effective special equipment based on the Customer's specification.



QUALITY

Aiming at providing for the best quality, the manufacturing process includes checks during production and detail test sessions for each equipment. The certified Integrated Managing System ensures the control of every manufacturing phase, starting from checking the components at reception and ending with the best package in relation to the transport type.



RESEARCH & DEVELOPMENT

ORTEA SpA constantly collaborates with Universities and Business Partners in the research and development of new products and new technologies.



SYNERGY

By working together, marketing, design, production and after-sales service allow the Company to meet the necessities set forth by an increasingly globalised and competitive market.



EXPERTISE

ORTEA SpA pre- and after-sales organization is able to intervene quickly, analyzing the problems and providing the correct solution.



CUSTOMER SERVICE

The continuous monitoring and analysis of requests and claims carried out by the after-sales service enables the improvement the quality of both products and service to the Customer.

INDEX

CHAPTER 1	Pag.
SIZING AND SELECTION CRITERIA	14
CALCULATION OF POWER FACTOR CORRECTION STARTING FROM ENERGY BILL	15
CAPACITORS MODELS AND PERFORMANCES WITHIN POWER CORRECTION SOLUTIONS	17
SOLUTIONS AND COMPONENTS OF AUTOMATIC POWER FACTOR CORRECTION BANKS	18
CHAPTER 2	Pag.
POWER FACTOR CORRECTION SOLUTIONS WITH HIGH GRADIENT METALLIZED POLYPROPYLENE CAPACITORS	27
CHAPTER 3	Pag.
POWER FACTOR CORRECTION SOLUTIONS WITH HIGH GRADIENT METALLIZED POLYPROPYLENE PLUS CAPACITORS	43
CHAPTER 4	Pag.
REACTIVE POWER REGULATOR	58
CHAPTER 5	Pag.
DIMENSIONS	63
CHAPTER 6	Pag.
TECHNICAL NOTES	73
APPENDIX	Pag.
TABLE	78

SIZING AND SELECTION CRITERIA

To correctly correct power factor of a LV electrical system we must start from the target we want to achieve.

Meaning:

- A higher power factor as measured "at the energy counter" compared to that imposed by the energy authority for excess of reactive energy consumption, so to avoid penalties and / or risk detachment from the network.
- The reduction of currents (and therefore of joules losses and voltage drops) in longer and intensively loaded plant sections.

Depending on the electrical loads features present in the system (working cycle, power, power factor), topology (radial, ring, etc) and the extension of the plant itself, once calculated the power factor correction requirement, it will be clear how to size the capacitor bank.

LV PFC methods

The most common methods are distributed power factor correction (each of the utilities is equipped with its own unit for power factor correction, typically fixed) and centralized power factor correction (a single automatic PFC system is installed and dedicated to the whole plant). It is also possible to create "mixed" solutions according to the peculiarity of the plant.

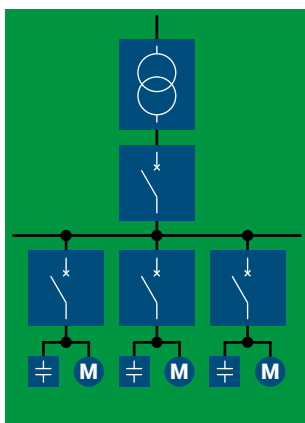

Distributed power factor correction

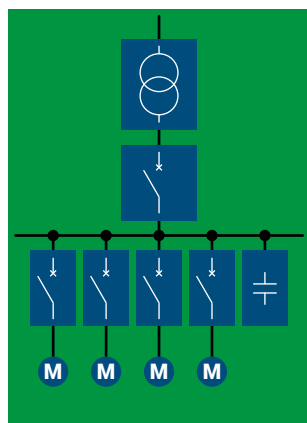

Centralized power factor correction

PF improvement of an asynchronous motor

Typical application of distributed power factor correction is that for a three-phase asynchronous motor. The PFC unit is chosen from tables, remembering to pay attention to the self-excitation risk.

Motor power		Required reactive power [kvar]				
HP	KW	3000 rpm	1500 rpm	1000 rpm	750 rpm	500 rpm
0,4	0,55	–	–	0,5	0,5	–
1	0,73	0,5	0,5	0,6	0,6	–
2	1,47	0,8	0,8	1	1	–
3	2,21	1	1	1,2	1,6	–
5	3,68	1,6	1,6	2	2,5	–
7	5,15	2	2	2,5	3	–
10	7,36	3	3	4	4	5
15	11	4	5	5	6	6
30	22,1	10	10	10	12	15
50	36,8	15	20	20	25	25
100	73,6	25	30	30	30	40
150	110	30	40	40	50	60
200	147	40	50	50	60	70
250	184	50	60	60	70	80

PF improvement of a Power Transformer

In MV electrical systems it is useful to compensate for the reactive power of the MV/LV transformer that supplies the LV part of the system. The required power is worked out starting from the percentage of no-load current (10%). In the absence of this data, the following table can be used.

Power transformer [kVA]	Standard		Low losses	
	Oil [kvar]	Resin [kvar]	Oil [kvar]	Resin [kvar]
10	1	1,5	–	–
20	2	1,7	–	–
50	4	2	–	–
75	5	2,5	–	–
100	5	2,5	1	2
160	7	4	1,5	2,5
200	7,5	5	2	2,5
250	8	7,5	2	3
315	10	7,5	2,5	3,5
400	12,5	8	2,5	4
500	15	10	3	5
630	17,5	12,5	3	6
800	20	15	3,5	6,5
1000	25	17,5	3,5	7
1250	30	20	4	7,5
1600	35	22	4	8
2000	40	25	4,5	8,5
2500	50	35	5	9
3150	60	50	6	10

CALCULATION OF POWER FACTOR CORRECTION STARTING FROM ENERGY BILL

The calculation of the size of power factor correction required for the system depends on active power (P), from the value of $\cos \varphi$ that we want to achieve ($\cos \varphi_2$), and from the existing value of $\cos \varphi$ of the system ($\cos \varphi_1$).

This evaluation can be carried out either from the project data or, for existing plants, from the values shown on the monthly energy bill (for the active power data, refer to the maximum demand active power, or to the contractual active power; or energies consumed in each time band).

In general, the power factor in the F1 and F2 bands is shown on the consumption bill; if not present it can be calculated from the values of active energy E_a and reactive energy E_r :

$$\cos \varphi_1 = \frac{E_a}{\sqrt{(E_a^2 + E_r^2)}}$$

Once the $\cos \varphi_1$ of the system is known, it should be known which is the target ($\cos \varphi_2$) and according to these two data it is possible to identify in table 1 the coefficient with which to multiply the active contract power, so identifying the necessary reactive power. If there would be a PFC system in the system to be replaced, the reactive power value found must be appropriately increased.

Starting power factor	Target power factor							
	0,90	0,91	0,92	0,93	0,94	0,95	0,96	0,97
0,67	0,624	0,652	0,682	0,713	0,745	0,779	0,816	0,857
0,68	0,594	0,623	0,652	0,683	0,715	0,750	0,787	0,828
0,69	0,565	0,593	0,623	0,654	0,686	0,720	0,757	0,798
0,70	0,536	0,565	0,594	0,625	0,657	0,692	0,729	0,770
0,71	0,508	0,536	0,566	0,597	0,629	0,663	0,700	0,741
0,72	0,480	0,508	0,538	0,569	0,601	0,635	0,672	0,713
0,73	0,452	0,481	0,510	0,541	0,573	0,608	0,645	0,686

Extract from Table 1 (See the full table in the APPENDIX).

Example

System with contractual power:

$$P = 300\text{kW}$$

The Energy bill shows a consumption:

$$E_a = 32.170\text{kWh}$$

$$E_r = 32.652\text{kvarh}$$

We calculate the value of $\cos \varphi_1$:

$$\cos \varphi_1 = \frac{32170}{\sqrt{(32170^2 + 32652^2)}} = 0,7$$

In the table, by choosing 0.70 as the initial power factor and 0.97 as the final power factor, we identify a coefficient equal to 0.77.

The reactive power requirement is therefore equal to:

$$Q_c = 0,77 * 300 = 231\text{kvar}$$

In the plant there is an old PFC system of 190kvar rated power, but now able to supply 100kvar only (measured with ammeter clamps).

The actual reactive power requirement is therefore equal to 331 kvar.

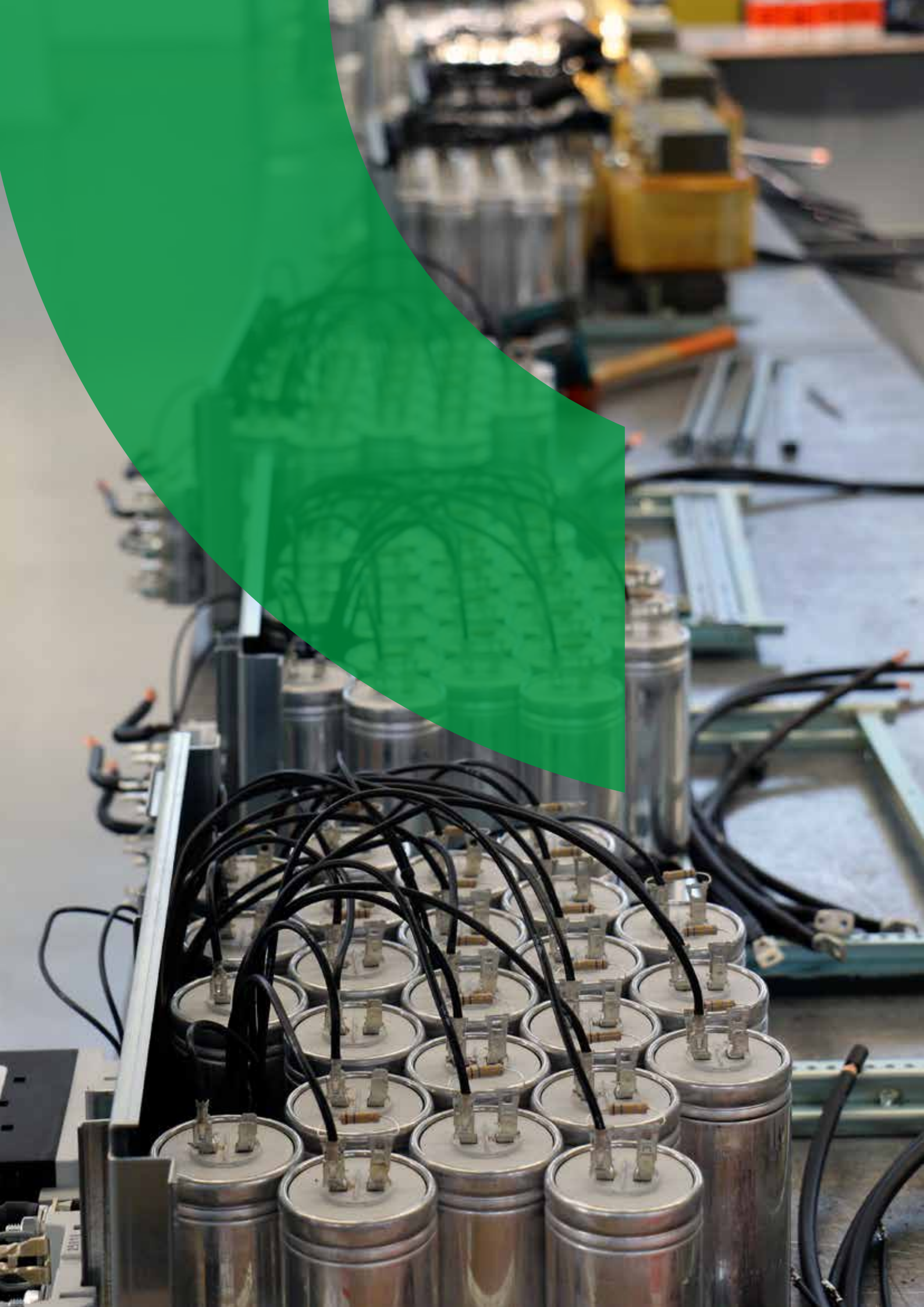

CAPACITORS MODELS AND PERFORMANCES WITHIN POWER CORRECTION SOLUTIONS

Once defined the power factor correction required for the plant and the type to be applied (centralized, distributed, mixed), it is a matter of choosing the equipment according to the market offer.

The main element of a power correction system is the capacitor: it is therefore important to choose it strong and of good quality.



High gradient metallized polypropylene capacitors



They are dry capacitors made by wrapping a high gradient metallized polypropylene film with metal layer thickness modulated and filled with resin.

The metallization thickness modulation allows to greatly improve the capacitors in terms of:

- Increase in power density (kvar/dm³) with a consequent power size reduction of the power factor correction systems.
- Robustness improvement against voltage surges, for greater reliability even in systems with the presence of voltage fluctuations due to the network or maneuvers on the system.
- Improved behavior of the internal short circuit withstand.



High gradient metallized polypropylene plus capacitors



They are dry capacitors made by wrapping a high gradient metallized polypropylene film realised with “wavy cut” technology with metal layer thickness modulated and filled with resin. The thickness of the polypropylene film is greater than for standard capacitors. The constructive characteristics allow the operation even at high ambient temperatures, as shown in the table below. They are used in power factor correction systems particularly suitable for heavy duty use.

Main features of the different types of capacitors

Main features of the different types of capacitors	High gradient metallized polypropylene capacitors		High gradient metallized polypropylene plus capacitors	
	-25/D		-25/+70 °C	
Temperature category (IEC 60831-1)*				
Max overload	1,3xIn	continuous	1,3xIn	continuous
	2xIn	380s every 60 min.	2xIn	500s every 60 min.
	3xIn	150s every 60 min.	3xIn	180s every 60 min.
	4xIn	70s every 60 min.	4xIn	90s every 60 min.
	5xIn	45s every 60 min.	5xIn	50s every 60 min.
Life expectancy at temperature cat. -25/D	100.000h		150.000h	
Life expectancy at climatic category	100.000h		100.000h	

* Max operating temperature: it is the one measured in the environment surrounding the capacitor.

SOLUTIONS AND COMPONENTS OF AUTOMATIC POWER FACTOR CORRECTION BANKS

In the majority of industrial plants the power factor correction system is centralized, with high capacity capacitor banks usually equipped with harmonic blocking reactors to protect capacitors from harmonics in the current.

When choosing a capacitor bank, it is necessary to pay attention not only to the quality of the capacitors inside the cabinet, but also to the quality of the other components and to the different solutions adopted by the manufacturer, in order to choose a device which will be efficient, long-lasting and easy to maintain.

Internal structure

ORTEA SpA manufactures all ICAR APFC with removable rack. It is preferable to choose a capacitor bank with removable racks: it's the best way to reduce time and problems during maintenance.

Regulator

It is the intelligent element, which controls the capacitor bank, so it is very important. The regulators on board the ICAR APFC are all microprocessor-based, with several measuring and alarm functions: they will help you understand how the APFC works and how the electrical system to be rephased behaves. You will appreciate it a lot during the capacitor bank's life and in particular when there will be problematic situations.

Contactors

In order to guarantee excellent long life and reliability, ORTEA SpA uses only good well-executed contactors. For standard PFC systems, contactors have to be with damping resistors to limit capacitors inrush current (AC6-b). For detuned PFC systems are enough standard contactors (the function of the peak smoothing it is performed by the blocking reactance).

Load break switch

It is the operation element, the one which has to bear the current of the capacitor bank also in case of overload. According to IEC 60831-1 regulation it has to be dimensioned with a nominal current which is at least 1.43 times the nominal current of the capacitor bank.

Steps

ORTEA SpA manufactures ICAR APFC with a step-by-step that can ensure good accuracy in the correction of the power factor. Typically ICAR realizes its APFC with linear steps, which allows the optimization of the number of electrical combinations obtainable.

Harmonic blocking reactors

In detuned APFC, intended for plants with distorted currents and/or resonance risks, the reactors are intended to defend capacitors from harmonic currents, which would damage them. ORTEA SpA designs and builds most of the reactors used in its ICAR APFC, based on the considerable experience gained.

Ventilation

The ICAR APFC are all made with forced ventilation. This reduces the thermal stress of the on-board capacitors, whether electrically (harmonic overload) and/or ambient (high temperature in the cabin).

Filters for the ventilation system

They protect the capacitor bank from the entrance of dust and foreign bodies, which could worsen its thermal situation. During the commissioning, especially if with cable arrival from below, it must be carefully placed so that inbound there are no alternative routes for cooling air: this occurs through the opening of cables passage, if it is not sealed appropriately with ad hoc shaped sets or foams.



Fix power factor correction systems



SUPERriphaso

Fixed Power factor correction for three-phase systems, modular plastic housing with IP40 protection degree. The modularity of the family SUPERriphaso allows to obtain the necessary power composing more modules with a simple and quick electrical and mechanical connection.

For powers from 5 to 50kvar at 400V.

The SUPERriphaso can only be installed in a vertical position.



MICROfix

Power factor correction for fixed three-phase systems, in metal enclosure with IP3X protection degree. MICROfix is equipped with an integrated door lock isolating switch, signal lamps and fuses.

For power up to 50kvar at 400V.

Automatic power factor correction systems



MICROmatic

It is the smaller size of automatic power factor correction bank, suitable for small users power factor correction. It is made with modular concept (MICROrack) to simplify the management of spare parts and maintenance. For reactive power up to 64kvar at 400V in very small dimensions. Allows you to have up to 19 steps for optimal power factor correction in the presence of highly variable loads or characterized by long periods of "no load" operation.



MINImatic

For small/medium powers automatic power factor correction, can deliver up to 225kvar 400V, depending on the version. It is made with completely removable rack (MINIRack) to simplify management and maintenance.

Very flexible Framework, allows the realization of many variations as shown in the available options table. MINImatic is also available in a version with harmonic blocking reactors and cable entry from bottom.



MIDImatic

Automatic power factor correction medium power, can deliver up to 450kvar at 400V depending on the version. It is made with easily removable racks, and is also available in the detuned version.

It shares many components (including racks) with the mirrored MULTImatic families, for greater robustness and ease of regaining spare parts.

Choice of cable entry (top/bottom).



MULTImatic

MULTImatic Power factor correction automatic for large users, allows systems of up to several Mvar, with master-slave logic.

MULTImatic is made with rack (MULTIrack) for easy replacement and maintenance.

It is available also in SPEED series (for fast loads), detuned, IP55 (where IP4X wasn't enough), with cable entry from top or bottom.

The distribution of power is with robust aluminium bars (copper on request).

Frameworks of standard equipments made from multiple columns side by side are equipped with a disconnector and a cable entry in each column. Available framework on multiple columns with one single cable entry (consult us).

Note: All fixed and automatic systems must only be mounted in a vertical position.

Automatic Capacitor Banks:

Standard features

These are the common features to all automatic banks: PFC regulator with temperature control, RAL 7035 colour, working voltage U_e of 400V (for different voltage consult us).

	MICRO matic	MINI matic	MIDI matic	MULTI matic
Cable incoming	top/bottom	top	bottom	bottom*
Ventilation	forced	forced	forced	forced
PFC regulator	5LGA	5LGA	8LGA**	8BGA
Degree of protection	IP3X	IP3X	IP3X	IP4X

* MULTImatic has, in standard, a disconnecter and a cable entry for each column. For versions of multiple columns with single cable entry consult us.

** MIDImatic FH20 is equipped with 8BGA.

Option

The banks can be made with the following optional equipment: consult us.

	MICRO matic	MINI matic	MIDI matic	MULTI matic
Cable incoming top/bottom	yes	yes (4)	yes (4)	yes (4)
IP55 Degree (cable incoming)	no	yes (bottom)	no	yes
Remote communication (1)	no	no	yes	yes
Control and protection module MCP5	no	no	yes (FH20)	yes (2)
Other paint color (upon request)	yes	yes	yes	yes
Automatic circuit breaker	no	yes (5)	yes	yes
Fuse melting signaling	no	yes	no	yes
Other Short Circuit fault withstand level	no	no	no	yes
Thyristor Switched bank (3)	no	no	no	yes
Controller Remote Software	yes	yes	yes	yes
Modem for Remote Control	no	no	no	yes
Fused main Switch	no	yes	yes	yes

(1) The regulator can be equipped with additional modules to communicate.

(2) For better protection of power factor correction system against max THD and max Temp. MULTImatic of FH20, FH30, FV25, FV25V, FV35 "detuned" families are equipped in standard with integrated MCP5 in the RPC 8BGA controller.

(3) The static switches replace the normal electromechanical contactors and allow the $\cos \varphi$ adjustment even in the presence of loads with sudden changes in absorption.

(4) To be specified in the order.

(5) Contact us.

Thyristor Switched Capacitor Banks (speed)

The MULTImatic series can be made with thyristor switches (SPEED version). Compared to traditional power factor correction systems, enables obtaining interesting performances thanks to the reaction speed of thyristors, (SCR) that control capacitors banks/steps.

By this solution the following performances are available:

- Switching speed: all the reactive power of the bank can be switched in about 60 ms. This is particularly suitable for plants characterized by fast changing loads (mixers, robots, welders) that could create problems to traditional electromechanical contactors used in standard power factor correction banks.
- Capacitor switching with minimization of the transient current peak. Particularly suitable for plants which power factor correction banks has to perform a great numbers of maneuvers and in presence of devices sensitive to transient over voltage/currents.
- Silence: with no mechanical components on the move, the real time capacitor banks are really suitable for applications where the installation of the power factor correction switchboard occurs near places which require minimum noises (banks, data elaboration centres, theatres, cinemas, libraries, schools, etc).
- Reduced maintenance: the lack of mechanical parts reduces the stress on the switchboard which therefore needs a little periodical maintenance compare to systems with traditional electromechanical contactors. This characteristic is really useful in rooms with conducting powder that could through the conductors into crises.



Power Factor Correction Tuned Filters

MINImatic, MIDImatic and MULTImatic can be used for perform harmonic filtering. They are banks with reactance connected in series to the capacitors. The LC circuit made in this way, has a network resonant frequency that is different from the network frequency (50Hz) and depending on the electric values of the components used (resistance, capacity, inductance) are obtained "detuned" filters or "absorption" filters. These are preferable solutions for those plants characterized by the presence of harmonics due to distorting loads (lighting, power electronics, induction ovens, welders etc), for the reasons described below.

Blocking (detuned) filters

The detuned filters are designed to power factor correction of a system characterized by the presence of harmonics, "protecting" the capacitors that would be damaged. The addition of the filter does not change the system harmonic content: the harmonics will continue to flow without "enter" into power factor corrector.

The blocking filters have a tuning frequency f_D lower than that of the harmonic current that circulates in the system with lower order (typically the 5th): a blocking filter is much more robust the lower its tuning frequency. Typically, the tuning frequency f_D is 180-190Hz, but in systems with particularly high harmonic content, we realize blocking filters tuned to 135-140Hz and therefore particularly sound. The tuning frequency of a barrier filter can also be expressed with other indicators:

- Order of harmonicity N.
- Barrier factor p (also called "relative impedance" in the IEC 61642 art 2.5), which is usually expressed as a percentage.

Here are the relationships that link these quantities, indicating with f the network frequency, X_C the capacitive impedance of the capacitors and X_L the inductive impedance:

$$f_D = \frac{X_L}{X_C} \quad N = \frac{f_D}{f} \quad f_D = \frac{f}{\sqrt{p}}$$

Due to the Ferranti effect, in the detuned systems the voltage which insists on the capacitors (U_C) is higher than that of the network U according to the following relation:

$$U_C = \frac{U}{1-p}$$

For this reason the capacitors in detuned systems have to be selected with a suitably high nominal voltage.

Absorption passive filters

Absorption filters are meant for plant power factor correction capacitors and, at the same time, totally or partially solve the problem of plant harmonics. The filter is tuned near the harmonic frequency to be eliminated and, consequently, that current will almost completely flow in the filter, leaving the electric circuit "clean".



Selection criteria depending on the type of plant

The choice of power factor correction equipment must be made by evaluating the design data of the system or, better yet, your electricity bills.

The choice of the power factor correction type must be carried out according to the following table, which shows on the ordinate the rate of harmonic distortion of the plant current (THDI_R%) and in abscissa the ratio between the reactive power Q_c (kvar) of the PFC bank and LV/MV transformer apparent power A_T (kVA).

In light of these data, it identifies the box with proposed families, starting from the family that ensures the proper functioning with the best quality/price ratio.

So you choose the automatic power factor corrector series. The fixed power factor correction must have the same electrical characteristics of the automatic.

The table was made starting from the following assumptions:

- Network voltage 400V.
- Initial power factor of the plant 0.7 inductive.
- Power factor target 0.95 inductive.
- Non linear load with 5°-7°-11°-13° harmonics current. High frequency harmonics are not allowed.

The hypotheses used are general and valid in the most of cases. In particular situations (harmonics coming from other branch of network, presence of rank equal to or a multiple of 3 harmonics) previous considerations may be invalid. In these cases, the guarantee of a correct choice of the equipment occurs only as a result of a measurement campaign of harmonic analysis of the network and/or the appropriate calculations.

ORTEA SpA disclaims any responsibility for incorrect choice of the product.

PFC systems selection guidelines

	Q _c / A _T ≤ 0,05		0,05 < Q _c / A _T ≤ 0,1		0,1 < Q _c / A _T ≤ 0,15		0,15 < Q _c / A _T ≤ 0,2		0,2 < Q _c / A _T ≤ 0,25		Q _c / A _T > 0,25	
THDI _R % > 27	HP10	VP10	FH20 FH30	FV25	FH20 FH30	FV25	FH20 FH30	FV25	FH20 FH30	FV25	FH20 FH30	FV25
20 < THDI _R % ≤ 27	HP10	VP10	FH20 FH30	FV25	FH20 FH30	FV25	HP20	VP20	HP30	VP20	FH20 FH30	FV25
12 < THDI _R % ≤ 20	HP10	VP10	FH20 FH30	FV25	FH20 FH30	FV25	HP20	VP20	HP30	VP20	FH20 FH30	FV25
THDI _R % ≤ 12	HP10	VP10	HP20 HP30	VP20	HP30	VP20	HP20	VP10	HP30	VP20	FH20 FH30	FV25

The table relates to standard power factor correction for 400V networks. For networks with different voltages, consult us.

Application example

For example, consider a MV connected system through a MV/LV 1000kVA transformer, and with a THDI_R% equal to 25%.

Assuming that the power factor correction system to be installed has a reactive power of 220kvar, the ratio Q_c/A_T is equal to 0.22.

The recommended power factor correction is therefore that in the box identified from the abscissa 0.2 < Q_c/A_T ≤ 0.25 and the ordinate 20 < THDI_R% ≤ 27%.





You can choose an HP30 family device, or go to the VP20 family.

The choice of the power factor correction unit needed for the installation must be made by evaluating the design data of the installation or, even better, the electricity bills.

Standard power factor correction

The standard power factor correction is used in those plants where there are no current heavily deformed (verify the THD% data of the system current, which must be less than $THDI_r\%$ of the selected power factor correction family) or resonance problems (see the table selection criteria).

If the harmonics presence in the plant is not negligible, are preferred solutions with reinforced capacitors (i.e. with an higher nominal voltage than that of the network).

Capacitor construction technology	Range and nominal values	FIX		AUTOMATIC				
		SUPER riphaso	MICRO fix	MICRO matic	MINI matic	MIDI matic	MULTI matic	
 High gradient metallized polypropylene	HP10	$THDI_r \leq 12\%$ $THDI_c \leq 50\%$ $U_N = 415V$		✓	✓	✓	✓	✓
 High gradient metallized polypropylene	HP20	$THDI_r \leq 20\%$ $THDI_c \leq 70\%$ $U_N = 460V$		✓	✓	✓	✓	✓
 High gradient metallized polypropylene	HP30	$THDI_r \leq 27\%$ $THDI_c \leq 85\%$ $U_N = 550V$	✓			✓		✓
 High gradient metallized polypropylene plus	VP10	$THDI_r \leq 27\%$ $THDI_c \leq 85\%$ $U_N = 400V$	✓	✓	✓	✓		✓
 High gradient metallized polypropylene plus	VP20	$THDI_r \leq 27\%$ $THDI_c \leq 90\%$ $U_N = 460V$	✓			✓		✓

The table relates to standard power factor correction for 400V networks. For networks with different voltages, consult us.

Power factor correction with blocking reactors

The power factor correction with blocking reactors (this solution is called in different ways in the technical literature such as "blocking filters", or "detuned filters", or "detuned power factor correctors", etc.) is a solution used when a current flows in the electric system with a high harmonic content (THD) and / or with the resonance risk with the MV/LV transformer.

In these cases, the installation of a "normal" power factor corrector, devoid of blocking reactors, can cause the rapid degradation of the capacitors and cause dangerous electrical and mechanical stresses in the components of power plant (cables, busbars, switches, transformers).





Chokes protect the capacitors by harmonics and at the same time exclude the resonances risk; leave without sacrificing the harmonic content of the current system (if you want to reduce the system harmonic content, you must install active or passive filters. Consult us).

This type of power factor correction is therefore to be preferred for systems with important non-linear loads (lighting not luminescent, power electronics, VSD, soft starters, induction furnaces, welding machines...).

ORTEA SpA offers two types of solutions with power factor correction with blocking reactors: one with 180Hz blocking frequency (detuned to 3.6 times the line frequency) and another one with 135Hz (2.7).

It's correct noting that the lower the tuning frequency is the more robust is the cabinet, because the reactor should have a larger iron core.

ORTEA SpA power factor correction solutions with blocking reactor, are made with inductors produced in-house. In addition are used only capacitors with rated voltage higher than that of the network, to ensure strength and durability counteracting the Ferranti effect (permanent overvoltage on the capacitor due to the blocking inductance).

Capacitor construction technology	Range and nominal values	FIX		AUTOMATIC				
		SUPER riphaso	MICRO fix	MICRO matic	MINI matic	MIDI matic	MULTI matic	
 High gradient metallized polypropylene	FH20	$THDI_r < 100\%$ $THDV_r \leq 6\%$ $U_N = 550V$ $f_D = 180Hz (n=3,6)$		✓		✓	✓	✓
 High gradient metallized polypropylene	FH30	$THDI_r < 100\%$ $THDV_r \leq 6\%$ $U_N = 550V$ $f_D = 135Hz (n=2,7)$				✓		✓
 High gradient metallized polypropylene plus	FV25	$THDI_r < 100\%$ $THDV_r \leq 6\%$ $U_N = 460V$ $f_D = 180Hz (n=3,6)$		✓				✓
 High gradient metallized polypropylene plus	FV25V	$THDI_r < 100\%$ $THDV_r \leq 8\%$ $U_N = 460V$ $f_D = 180Hz (n=3,6)$						✓
 High gradient metallized polypropylene plus	FV35	$THDI_r < 100\%$ $THDV_r \leq 6\%$ $U_N = 550V$ $f_D = 135Hz (n=2,7)$						✓

The table relates to standard power factor correction for 400V networks. For networks with different voltages, consult us.

Selection of the CT, its position and how to connect it to the APFC bank

The electronic regulator installed on the capacitor bank calculates the power factor of the plant that has to be corrected by measuring a phase to phase voltage and the related 90° lagging current.

The wiring which is necessary to obtain the signal is realized inside the APFC bank, therefore for a correct operation it is necessary to properly choose, position and wire the CT, which is not included in the capacitor bank.

The CT has to be chosen according to the characteristics of the load that has to be compensated and to the distance between its point of installation and the regulator:

- The primary of the CT has to be chosen according to the current absorbed by the loads that have to be compensated; it does not depend on the power of the APFC bank. The primary has to be approximately the same (or slightly higher) of the maximum current which can be absorbed by the load. However it is better not to choose a CT with an excessive primary: if this happens, when the load will absorb a limited current the CT will supply to the secondary a current which will be too weak to be calculated by the regulator. For example, if the load that has to be compensated has a maximum absorption of 90A, it is advisable to choose a CT with a 100A primary.

- The secondary of the CT must be 5A. If you want to use a CT with 1A secondary you will have to parameterize the regulator.
- The performance of the CT (apparent power) must be chosen taking into consideration the dissipation of the cable which connects the CT to the APFC bank. The table below shows how many VA are dissipated for each linear meter of a cable with different sections: to correctly calculate the wiring dissipation you need to consider the total route of the cable (way there and way back).

Cable section [mm ²]	VA for each meter of cable at 20°C ¹
2,5	0,410
4	0,254
6	0,169
10	0,0975
16	0,0620

¹. For each 10°C of temperature variation, the VA absorbed by the cables increase by 4%, the above values are extracted from the typical resistance of flexible class 5 cables.

- The precision of the CT is very important to avoid problems of bad functioning of the APFC bank. Choose class 1 CT or, even better, class 0,5.

The wiring has to be carried out with an appropriate section, to not excessively weaken the signal coming from the secondary of the CT: choose a 2,5mm² cable section only if the wiring between the CT and regulator is 1 m max. Use cable section at least 4mm² for wirings up to 10m, 6mm² up to 20m and 10 mm² for more than 20m wirings (however not recommended).

Connect to earth one of the two clamps of the CT. It is strongly recommended to use a dedicated CT for the APFC bank, to avoid to put in series more than one device (ammeter, multimeter) on the same CT.

Position of the CT

As before mentioned, the electronic regulator installed on the APFC bank accurately calculates the cosφ of the plant if it can measure a phase to phase voltage and the related 90° lagging current.

Since the wiring is already internally carried out on the APFC bank on L2 and L3 phases downstream the load break switch (clamps 9 and 10, see the scheme), the CT must be positioned on phase L1 of the power cable upstream the APFC bank (below image, in green). The side of the CT with P1 (or K) mark has to be oriented to the line (upstream). The wiring of the secondary of the CT (clamps S1 and S2) to the APFC bank (clamps L and K) is made by the customer, according to the instructions in the previous points.

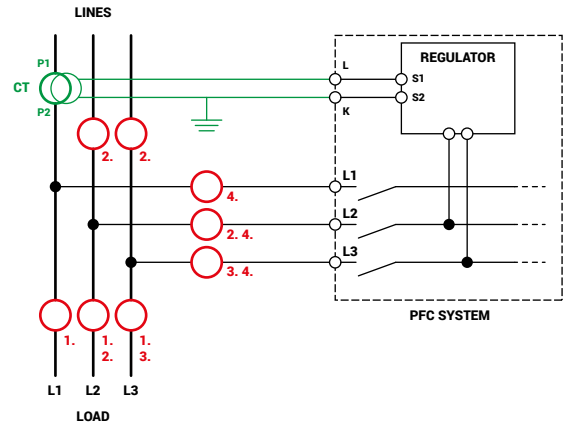

Please note that possible positions here below indicated in red are wrong because:

1. the CT is downstream the APFC bank
2. the CT is on the wrong phase (L2)
3. the CT is on the wrong phase (L3)
4. the CT is installed on the cable goes to the APFC bank.

For further information read the regulator's manual.

Selection of APFC bank protection device

The low Voltage APFC bank equipped with self-healing capacitors are compliant with IEC EN 60831-1/2 (capacitors) and IEC EN 61439-1/2, IEC EN 61921 (complete devices) regulations.

According the above-mentioned regulations, the capacitor bank must be able to work in continuous supporting an rms value of 1.3 times the nominal current (this regulation takes into consideration that, when harmonics are present in the system, capacitors are overloaded).

Known this, and considering that APFC banks can have a tolerance on the nominal reactive power up to 10% more than nominal one, it is possible to indicate the calculation necessary for the choice and setup of the protection device to be installed upstream the APFC bank (Circuit Breaker or Fused Load Break Switch).

Calculation of the current

Maximum absorbed current:

$$I_{n_{\max}} = 1,3 \times 1,1 \times \frac{Q_n}{\sqrt{3} \times V_n} = 1,43 I_n$$

Where I_n is the nominal current of the device calculated with the data present on the label, that is to say V_n (nominal voltage of the network) and Q_n (nominal reactive power of the APFC bank at the nominal voltage of the network). It is therefore necessary to choose and install a protection device (Circuit Breaker or Fused Load Break Switch) with current $\geq I_{n_{\max}}$ value according to which it has to be dimensioned the cable (or bars) which supply the APFC bank.



On board capacitors technology:

- High gradient metallized polypropylene
- High gradient metallized polypropylene plus

Available solutions

Main technical characteristics

Common technical characteristics

CHAPTER 2

HPO

Automatic PFC system

MICROmatic - MINImatic - MIDImatic - MULTImatic

U _e	U _n	U _{max} *	f	THDI _n %	THDI _e %**
415V	415V	455V	50Hz	≤12%	≤50%

* Maximum admissible value according to IEC 60831-1.
** Attention: in this conditions of load network harmonic amplification phenomena is possible.

Technical characteristics

Rated operational voltage U_e=400-415V

Rated frequency 50Hz

Max current overload in (bank) 1,3 In

Max current overload in (capacitors @40°C)
 1,3 In (continuous)
 2 In (x380s every 60 minutes)
 3 In (x150s every 60 minutes)
 4 In (x70s every 60 minutes)
 5 In (x45s every 60 minutes)

Max overload Vn (banks) 1,1xU_n

Max overload Vn (capacitors) 3xU_n (per 1 minute)

Insulation voltage 690V

Temperature class (bank) -5/+40°C

Temperature class (capacitors) -25/+55°C

Discharge device mounted on each bank

Installation indoor

Service continuous

Internal connection delta

Operation devices capacitors contactors (AC6b)

Total losses ~2W/kvar

Inner surface finish zinc passivation

Standards (bank) IEC 61439-1/2, IEC 61921

Standards (capacitors) IEC 60831-1/2

Generalities

- Zink-passivated metallic enclosure painted with epoxidic dust paint, colour RAL 7035.
- Auxiliary transformer to separate power and auxiliary circuit parts (110V).
- Load-break switch with door interlock.
- Special contactors with damping resistors to limit capacitors inrush current (AC6b).
- FS17 450/750V self-extinguish cable according to EN 50525 - EN 50575 - EN 50575/A1.
- Microprocessor Power Factor Correction relay.
- CRM25 single phase self-healing metallized polypropylene capacitor with U_n=415V rated voltage.

Part number	Power [kvar]		Steps U _e =400V	Electrical steps number	Banks		LBS ¹ [A]	I _{sc} ² [kA]	PFC ratio	Weight [kg]	Dimensions (see chap. 6)		
	U _e =415V	U _e =400V			[kvar]	[A]					[kg]	[F3X]	[IP4X]
MICROmatic													
ICDAKF214050652	14	12,6	1,8-3,6-7,2	7	1,8-3,6-7,2	63	50	SLGA	12	49	-	-	
ICDAKF22050652	20	18	3,6-7,2-14,4	5	3,6-7,2-14,4	80	50	SLGA	13	49	-	-	
ICDAKF22050652	22	19,8	1,8-3,6-2x7,2	11	1,8-3,6-2x7,2	80	50	SLGA	16	50	-	-	
ICDAKF228050652	28	25,2	3,6-7,2-14,4	7	3,6-7,2-14,4	80	50	SLGA	14	49	-	-	
ICDAKF23050652	30	27	1,8-3,6-7,2-14,4	15	1,8-3,6-7,2-14,4	80	50	SLGA	17	50	-	-	
ICDAKF236050652	36	32,4	3,6-2x7,2-14,4	9	3,6-2x7,2-14,4	100	50	SLGA	18	50	-	-	
ICDAKF238050652	38	34,2	1,8-3,6-2x7,2-14,4	19	1,8-3,6-2x7,2-14,4	100	50	SLGA	20	50	-	-	
ICDAKF244050652	44	39,6	3,6-7,2-2x14,4	11	3,6-7,2-2x14,4	100	50	SLGA	22	50	-	-	
ICDAKF252050652	52	46,8	3,6-7,2-14,4-21,6	13	3,6-2x7,2-2x14,4	125	50	SLGA	24	50	-	-	
ICDAKF260050652	60	54	3,6-7,2-14,4-28,8	15	3,6-7,2-3x14,4	125	50	SLGA	26	50	-	-	
ICDAKF272050652	72	64,8	7,2-2x14,4-28,8	9	7,2-4x14,4	160	50	SLGA	28	50	-	-	
IFDAKF280050652	80	75	7,5-15-22,5-30	10	7,5	250	9	SLGA	41	55	-	60	
IFDAKF3112050652	112	105	7,5-15-22,5-2x30	14	30x7,5	250	9	SLGA	47	56	-	60	
IFDAKF3136050652	136	125	7,5-15-22,5-30-52,5	17	52,5-7,5	315	9	SLGA	51	56	-	60	
IFDAKF316050652	160	150	15-30-45-60	10	2x7,5	315	9	SLGA	54	56	-	60	
IFDAKF3192050652	192	180	15-30-60-75	12	30-2x7,5	400	9	SLGA	60	57	-	60	
IFDAKF3216050652	216	200	15-30-60-90	13	52,5-2x7,5	500	9	SLGA	65	57	-	60	
IFDAKF324050652	240	225	15-30-60-120	15	3x7,5	500	9	SLGA	69	57	-	60	
ILDFKF327550884	275	255	15-2x30-3x60	17	105-150	630	25	BLGA	170	64	-	-	
ILDFKF32920884	320	300	2x30-4x60	10	2x150	800	30	BLGA	185	64	-	-	
ILDFKF340050884	400	375	2x30-4x75	10	75-2x150	800	30	BLGA	200	64	-	-	
ILDFKF348050884	480	450	2x45-4x90	10	3x150	1000	30	BLGA	220	64	-	-	
INDAKF32050700	320	300	2x30-4x60	10	2x150	800	50	BBGA	190	-	72	75	
INDAKF340050700	400	375	2x37,5-4x75	10	75-2x150	1050	50	BBGA	210	-	72	75	
INDAKF348050700	480	450	2x45-4x90	10	3x150	1250	50	BBGA	230	-	72	75	
INDAKF356050700	560	525	2x52,5-4x105	10	75-3x150	1250	50	BBGA	270	-	74	81	
INDAKF364050700	640	600	2x60-4x120	10	4x150	2x600	50	BBGA	420	-	92	83	
INDAKF372050700	720	675	2x67,5-4x135	10	75-4x150	2x1250	50	BBGA	500	-	92	83	
INDAKF380050700	800	750	2x75-4x150	10	6x150	2x1250	50	BBGA	520	-	92	83	
INDAKF388050700	880	825	2x82,5-4x165	10	75-5x150	2x1250	50	BBGA	560	-	92	83	
INDAKF396050700	960	900	2x90-4x180	10	6x150	2x1250	50	BBGA	600	-	92	83	
INDAKF410450700	1040	975	2x97,5-4x195	10	75-6x150	2x1250	50	BBGA	620	-	94	85	
INDAKF41250700	1120	1050	2x105-4x210	10	2x75-6x150	2x1250	50	BBGA	660	-	94	85	

1. M/LTomatic of several columns have a disconnector and a cable entry for each column. See page 22.
2. Other values upon request. For MICROmatic and MIDImatic series short circuit withstand current conditioned by the upstream protective device.
3. For part numbers contact ORTEA SpA.

33

Range

Short description

Part numbers and detailed technical features, divided by family device size and cutting in kvar

POWER FACTOR CORRECTION SOLUTIONS WITH HIGH GRADIENT METALLIZED POLYPROPYLENE CAPACITORS



Range	Fix PFC systems	Automatic PFC systems	Racks	Nominal voltage U_e	Capacitors voltage U_N	THDI _R %	THDI _C %	I_{250Hz} %	THDV _R %	f_D
HP10	✓	✓	✓	400-415V	415V	≤12%	≤50%	–	–	–
HP20	✓	✓	✓	400-415V	460V	≤20%	≤70%	–	–	–
HP30	✓	✓	✓	400-415V	550V	≤27%	≤85%	–	–	–
FH20*	✓	✓	✓	400-415V	550V	100%	–	≤25%	≤6%	180Hz
FH30*		✓	✓	400-415V	550V	100%	–	>25%	≤6%	135Hz

* Also available in the /S version thyristor switched (see page 22).

Used capacitor

CRM25-1



Generalities

- High gradient metallized polypropylene capacitors.
- Metallic case with protection degree IP00.
- Internal overpressure protection system.
- Resin filling.

Technical characteristics

Rated operational voltage	Ue=415-460-550V
Rated frequency	50Hz
Max current overload I_n	1,3 I _n (continuous) 2 I _n (x380s every 60 minutes) 3 I _n (x150s every 60 minutes) 4 I _n (x70s every 60 minutes) 5 I _n (x45s every 60 minutes)
Max voltage overload V_n	3xU _N (for 1 minute)
Temperature class	-25/D
Life expectancy	100.000h
Capacitance tolerance	-5% ÷ +10%
Service	continuous
Construction type	high gradient polypropylene
Standards	IEC 60831-1/2

Range	Part number	Rated voltage U _N [V]	MAX voltage U _{MAX} [V]	Power [kvar]	Capacitance [μF]	Dimensions Ø x h [mm]	Weight [kg]	Pcs/box
HP10	6DCRM00069A50	415	455	0,69	12,2	60x90	0,25	36
	6DCRM00138A50	415	455	1,38	25,4	60x90	0,25	36
	6DCRM00275A50	415	455	2,75	50,8	60x140	0,5	36
	6DCRM00550A50	415	455	5,5	101,6	60x140	0,5	36
HP20	6DCRM00069B50	460	500	0,69	10,4	60x90	0,25	36
	6DCRM00138B50	460	500	1,38	20,7	60x90	0,25	36
	6DCRM00275B50	460	500	2,75	41,4	60x140	0,5	36
	6DCRM00550B50	460	500	5,5	82,7	60x140	0,5	36
HP30 FH20 FH30	6DCRM00069C50	550	600	0,69	7,2	60x90	0,25	36
	6DCRM00138C50	550	600	1,38	14,5	60x90	0,25	36
	6DCRM00275C50	550	600	2,75	28,9	60x140	0,5	36
	6DCRM00550C50	550	600	5,5	57,9	60x140	0,5	36
kit* HP10	ICRM25069415	415	455	0,69	12,2	310x70x120	1	3
	ICRM25138415	415	455	1,38	25,4	310x70x120	1	3
	ICRM25275415	415	455	2,75	50,8	310x70x120	1,5	3
	ICRM25550415	415	455	5,5	101,6	310x70x120	1,5	3
kit* HP20	ICRM25069460	460	500	0,69	10,4	310x70x120	1	3
	ICRM25138460	460	500	1,38	20,7	310x70x120	1	3
	ICRM25275460	460	500	2,75	41,4	310x70x120	1,5	3
	ICRM25550460	460	500	5,5	82,7	310x70x120	1,5	3
kit* HP30	ICRM25275550	550	600	2,75	28,9	310x70x120	1,5	3
	ICRM25550550	550	600	5,5	57,9	310x70x120	1,5	3

* Kit consists of 3 capacitors, nuts and washers, discharge resistors.

HP10

Fix PFC system MICROfix

U _e	U _N	U _{MAX} *	f	THDI _R %	THDI _C %**
400-415V	415V	455V	50Hz	≤12%	≤50%

* Maximum admissible value according to IEC 60831-1.

** Attention: in this conditions of load network harmonic amplification phenomena is possible.

Generalities

- Zink-passivated metallic enclosure painted with epossidic dust paint, colour RAL 7035.
- Load-break switch with door interlock.
- Fuses with high breaking power NH00-gG.
- FS17 450/750V self-extinguish cable according to EN 50525 - EN 50575 - EN 50575/A1.
- IP3X protection degree.
- CRM25 single phase self-healing metallized polypropylene capacitor with U_N=415V rated voltage.
- Discharge resistance.
- Signal lamp power on.

Technical characteristics

Rated operational voltage	U _e =400-415V
Rated frequency	50Hz
Max current overload I_n (bank)	1,3 I _n 1,3 I _n (continuous) 2 I _n (x380s every 60 minutes) 3 I _n (x150s every 60 minutes) 4 I _n (x70s every 60 minutes) 5 I _n (x45s every 60 minutes)
Max current overload I_n (capacitors @40°C)	
Max overload V_n (bank)	1,1xU _e
Max overload V_n (capacitors)	3xU _N (for 1 minute)
Insulation voltage	690V
Temperature class (bank)	-5/+40°C
Temperature class (capacitors)	-25/+55°C
Discharge device	mounted on each bank
Installation	indoor
Service	continuous
Internal connection	delta
Total losses	~ 2W/kvar
Inner surface finish	zinc passivation
Standards (bank)	IEC 61439-1/2, IEC 61921
Standards (capacitors)	IEC 60831-1/2

	Part number	Power [kvar]		LBS [A]	I _{cc} ¹ [kA]	Weight [kg]	Dimensions (see chap. 5)
		U _e =415V	U _e =400V				
MICROfix	IB3DKK211050987	11	10	40	50	9	43
	IB3DKK216550987	16,5	15	40	50	12	43
	IB3DKK222050987	22	20	80	50	13	43
	IB3DKK233050987	33	30	80	50	15	43
	IB3DKK243050987	43	40	125	50	18	44
	IB3DKK254050987	54	50	125	50	20	44

1. Altri valori a richiesta. Corrente di corto circuito condizionata da dispositivo di protezione da installarsi a monte.



Automatic PFC system

MICROmatic - MINImatic - MIDImatic - MULTImatic

U _e	U _N	U _{MAX} *	f	THDI _R %	THDI _C %**
400-415V	415V	455V	50Hz	≤12%	≤50%

* Maximum admissible value according to IEC 60831-1.

** Attention: in this conditions of load network harmonic amplification phenomena is possible.

Generalities

- Zink-passivated metallic enclosure painted with eposidic dust paint, colour RAL 7035.
- Auxiliary transformer to separate power and auxiliary circuit parts (110V).
- Load-break switch with door interlock.
- Special contactors with damping resistors to limit capacitors inrush current (AC6b).
- FS17 450/750V self-extinguish cable according to EN 50525 - EN 50575 - EN 50575/A1.
- Microprocessor Power Factor Correction relay.
- CRM25 single phase self-healing metallized polypropylene capacitor with U_N=415V rated voltage.

Technical characteristics

Rated operational voltage	U _e =400-415V
Rated frequency	50Hz
Max current overload I _n (bank)	1,3 I _n 1,3 I _n (continuous) 2 I _n (x380s every 60 minutes) 3 I _n (x150s every 60 minutes) 4 I _n (x70s every 60 minutes) 5 I _n (x45s every 60 minutes)
Max current overload I _n (capacitors @40°C)	
Max overload V _n (bank)	1,1xU _e
Max overload V _n (capacitors)	3xU _N (for 1 minute)
Insulation voltage	690V
Temperature class (bank)	-5/+40°C
Temperature class (capacitors)	-25/+55°C
Discharge device	mounted on each bank
Installation	indoor
Service	continuous
Internal connection	delta
Operation devices	capacitors contactors (AC6b)
Total losses	~ 2W/kvar
Inner surface finish	zinc passivation
Standards (bank)	IEC 61439-1/2, IEC 61921
Standards (capacitors)	IEC 60831-1/2

	Part number	Power [kvar]		Steps U _e =400V	Electrical steps number	Banks [kvar]	LBS ¹ [A]	I _{cc} ² [kA]	PFC relay	Weight [kg]	Dimensions (see chap. 5)		
		U _e =415V	U _e =400V								IP3X	IP4X	IP55 ³
MICROmatic	IC0AKF214050652	14	12,6	1,8-3,6-7,2	7	1,8-3,6-7,2	63	50	5LGA	12	49	-	-
	IC0AKF220050652	20	18	3,6-7,2-7,2	5	3,6-7,2-7,2	63	50	5LGA	13	49	-	-
	IC0AKF228050652	28	25,2	3,6-7,2-14,4	7	3,6-7,2-14,4	80	50	5LGA	14	49	-	-
	IC0AKF236050652	36	32,4	3,6-2x7,2-14,4	9	3,6-2x7,2-14,4	100	50	5LGA	18	50	-	-
	IC0AKF244050652	44	39,6	3,6-7,2-2x14,4	11	3,6-7,2-2x14,4	100	50	5LGA	22	50	-	-
	IC0AKF252050652	52	46,8	3,6-7,2-14,4-21,6	13	3,6-2x7,2-2x14,4	125	50	5LGA	24	50	-	-
	IC0AKF260050652	60	54	3,6-7,2-14,4-28,8	15	3,6-7,2-3x14,4	125	50	5LGA	26	50	-	-
MINImatic	IC0AKF272050652	72	64,8	7,2-2x14,4-28,8	9	7,2-4x14,4	160	50	5LGA	28	50	-	-
	IF0AKF280050652	80	75	7,5-15-22,5-30	10	75	250	9	5LGA	41	55	-	60
	IF0AKF311250652	112	105	7,5-15-22,5-2x30	14	30-75	250	9	5LGA	47	56	-	60
	IF0AKF313650652	136	125	7,5-15-22,5-30-52,5	17	52,5-75	315	9	5LGA	51	56	-	60
	IF0AKF316050652	160	150	15-30-45-60	10	2x75	315	9	5LGA	54	56	-	60
	IF0AKF319250652	192	180	15-30-60-75	12	30-2x75	400	9	5LGA	60	57	-	60
	IF0AKF321650652	216	200	15-30-60-90	13	52,5-2x75	500	9	5LGA	65	57	-	60
MIDImatic	IF0AKF324050652	240	225	15-30-60-120	15	3x75	500	9	5LGA	69	57	-	60
	IL0FKF327550884	275	255	15-2x30-3x60	17	105-150	630	25	8LGA	170	64	-	-
	IL0FKF332050884	320	300	2x30-4x60	10	2x150	800	30	8LGA	185	64	-	-
	IL0FKF340050884	400	375	2x38-4x75	10	75-2x150	800	30	8LGA	200	64	-	-
	IL0FKF348050884	480	450	2x45-4x90	10	3x150	1000	30	8LGA	220	64	-	-
	IN0AKF332050700	320	300	2x30-4x60	10	2x150	800	50	8BGA	190	-	72	75
	IN0AKF340050700	400	375	2x37,5-4x75	10	75-2x150	1250	50	8BGA	210	-	72	75
MULTImatic	IN0AKF348050700	480	450	2x45-4x90	10	3x150	1250	50	8BGA	230	-	72	75
	IN0AKF356050700	560	525	2x52,5-4x105	10	75-3x150	1250	50	8BGA	270	-	74	81
	IN0AKF364050700	640	600	2x60-4x120	10	4x150	2x800	50	8BGA	420	-	92	83
	IN0AKF372050700	720	675	2x67,5-4x135	10	75-4x150	2x1250	50	8BGA	500	-	92	83
	IN0AKF380050700	800	750	2x75-4x150	10	5x150	2x1250	50	8BGA	520	-	92	83
	IN0AKF388050700	880	825	2x82,5-4x165	10	75-5x150	2x1250	50	8BGA	560	-	92	83
	IN0AKF396050700	960	900	2x90-4x180	10	6x150	2x1250	50	8BGA	580	-	92	83
	IN0AKF410450700	1040	975	2x97,5-4x195	10	75-6x150	2x1250	50	8BGA	620	-	94	85
	IN0AKF411250700	1120	1050	2x105-4x210	10	2x75-6x150	2x1250	50	8BGA	660	-	94	85

1. MULTImatic of several columns have a disconnector and a cable entry for each column.

2. Other values upon request. For MICROmatic and MIDImatic series short-circuit withstand current conditioned by the upstream protective device.

3. For part numbers contact ORTEA SpA.

HP10

Racks

MICROrack - MINIRack - MULTIRack

U _e	U _N	U _{MAX} *	f	THDI _R %	THDI _C %**
400-415V	415V	455V	50Hz	≤12%	≤50%

* Maximum admissible value according to IEC 60831-1.

** Attention: in this conditions of load network harmonic amplification phenomena is possible.

Generalities

- Special contactors with damping resistors to limit capacitors inrush current (AC6b).
- FS17 450/750V self-extinguish cable according to EN 50525 - EN 50575 - EN 50575/A1.
- Fuses with high breaking power NH00-gG.
- CRM25 single phase self-healing metallized polypropylene capacitor with U_N=415V rated voltage.
- Discharge devices.

Racks can be used as spare parts in ICAR power factor correction systems properly maintained and in suitably ventilated / conditioned third-party electrical panels (max internal temperature 55°C).

MULTI-rack can also be used on MIDImatic systems from the production date 1st of June, 2016.

Technical characteristics

Rated operational voltage	U _e =400-415V
Rated frequency	50Hz
Max current overload I_n (rack)	1,3 I _n
Max current overload I_n (capacitors @40°C)	1,3 I _n (continuous) 2 I _n (x380s every 60 minutes) 3 I _n (x150s every 60 minutes) 4 I _n (x70s every 60 minutes) 5 I _n (x45s every 60 minutes)
Max overload V_n (rack)	1,1xU _e
Max overload V_n (capacitors)	3xU _N (for 1 minute)
Insulation voltage	690V
Temperature class (rack)	-5/+40°C
Temperature class (capacitors)	-25/+55°C
Discharge device	mounted on each bank
Installation	indoor
Service	continuous
Internal connection	delta
Total losses	~ 2W/kvar
Inner surface finish	zinc passivation
Standards (rack)	IEC 61439-1/2, IEC 61921
Standards (capacitors)	IEC 60831-1/2

	Part number	Power [kvar]		Steps U _e =400V	Weight	Dimensions
		U _e =415V	U _e =400V	[kvar]	[kg]	(see chap. 5)
MICRO rack	IC1DKK120050000	2	1,8	1.8	1.7	109
	IC1DKK140050000	4	3,6	3.6	2	109
	IC1DKK180050000	8	7,2	7.2	2	109
	IC1DKK216050000	16	14,4	14,4	2.3	109
MINI rack	IWOAKK216050000	16	15	15	4	110
	IWOAKK232050000	32	30	30	6	110
	IWOAKK256050000	56	52,5	22.5-30	11	110
	IWOAKK280050268	80	75	15-30-30	13	110
	IWOAKK280050000	80	75	7.5-15-22.5-30	14	110
MULTI rack	IXOAKK280050000	80	75	2x7.5-4x15	19	120
	IXOAKK316050000	160	150	2x15-4x30	27	120

HP20

Fix PFC system MICROfix

U _e	U _N	U _{MAX} *	f	THDI _R %	THDI _C %**
400-415V	460V	500V	50Hz	≤20%	≤70%

* Maximum admissible value according to IEC 60831-1.

** Attention: in this conditions of load network harmonic amplification phenomena is possible.

Generalities

- Zink-passivated metallic enclosure painted with epossidic dust paint, colour RAL 7035.
- Load-break switch with door interlock.
- Fuses with high breaking power NH00-gG.
- FS17 450/750V self-extinguish cable according to EN 50525 - EN 50575 - EN 50575/A1.
- IP3X protection degree.
- CRM25 single phase self-healing metallized polypropylene capacitor with U_N=460V rated voltage.
- Discharge resistance.
- Signal lamp power on.

Technical characteristics

Rated operational voltage	U _e =400-415V
Rated frequency	50Hz
Max current overload I_n (bank)	1,3 I _n 1,3 I _n (continuous) 2 I _n (x380s every 60 minutes) 3 I _n (x150s every 60 minutes) 4 I _n (x70s every 60 minutes) 5 I _n (x45s every 60 minutes)
Max current overload I_n (capacitors @40°C)	
Max overload V_n (bank)	1,1xU _e
Max overload V_n (capacitors)	3xU _N (for 1 minute)
Insulation voltage	690V
Temperature class (bank)	-5/+40°C
Temperature class (capacitors)	-25/+55°C
Discharge device	mounted on each bank
Installation	indoor
Service	continuous
Internal connection	delta
Total losses	~ 2W/kvar
Inner surface finish	zinc passivation
Standards (bank)	IEC 61439-1/2, IEC 61921
Standards (capacitors)	IEC 60831-1/2

	Part number	Power [kvar]			LBS [A]	I _{cc} ¹ [kA]	Weight [kg]	Dimensions (see chap. 5)
		U _N =460V	U _e =415V	U _e =400V				
MICROfix	IB3NLK170050987	7	6	5	40	50	8	43
	IB3NLK214050987	14	11	10	40	50	9	43
	IB3NLK219050987	19	16	15	40	50	12	43
	IB3NLK227050987	27	22	20	80	50	13	43
	IB3NLK241050987	41	33	30	80	50	15	44
	IB3NLK254050987	54	44	40	125	50	18	44
	IB3NLK266050987	66	54	50	125	50	20	44

1. Other values upon request. Short-circuit withstand current conditioned by the upstream protective device.



Automatic PFC system

MICROmatic - MINImatic - MIDImatic - MULTImatic

U _e	U _N	U _{MAX} *	f	THDI _R %	THDI _C %**
400-415V	460V	500V	50Hz	≤20%	≤70%

* Maximum admissible value according to IEC 60831-1.

** Attention: in this conditions of load network harmonic amplification phenomena is possible.

Generalities

- Zink-passivated metallic enclosure painted with epossidic dust paint, colour RAL 7035.
- Auxiliary transformer to separate power and auxiliary circuit parts (110V).
- Load-break switch with door interlock.
- Special contactors with damping resistors to limit capacitors inrush current (AC6b).
- FS17 450/750V self-extinguish cable according to EN 50525 - EN 50575 - EN 50575/A1.
- Microprocessor Power Factor Correction relay.
- CRM25 single phase self-healing metallized polypropylene capacitor with U_N=460V rated voltage.

Technical characteristics

Rated operational voltage	U _e =400-415V
Rated frequency	50Hz
Max current overload I _n (bank)	1,3 I _n 1,3 I _n (continuous) 2 I _n (x380s every 60 minutes) 3 I _n (x150s every 60 minutes) 4 I _n (x70s every 60 minutes) 5 I _n (x45s every 60 minutes)
Max current overload I _n (capacitors @40°C)	
Max overload V _n (bank)	1,1xU _e
Max overload V _n (capacitors)	3xU _N (for 1 minute)
Insulation voltage	690V
Temperature class (bank)	-5/+40°C
Temperature class (capacitors)	-25/+55°C
Discharge device	mounted on each bank
Installation	indoor
Service	continuous
Internal connection	delta
Operation devices	capacitors contactors (AC6b)
Total losses	~ 2W/kvar
Inner surface finish	zinc passivation
Standards (bank)	IEC 61439-1/2, IEC 61921
Standards (capacitors)	IEC 60831-1/2

	Part number	Power [kvar]			Steps U _e =400V	Electrical steps number	Banks [kvar]	LBS ¹ [A]	I _{cc} ² [kA]	PFC relay	Weight [kg]	Dimensions (see chap. 5)		
		U _N =460V	U _e =415V	U _e =400V								IP3X	IP4X	IP55 ³
MICROmatic	IC0JLF214050652	14	11	10,5	1,5-3-6	7	1,5-3-6	63	50	5LGA	12	49	-	-
	IC0JLF222050652	22	18	16,5	1,5-3-2x6	11	1,5-3-2x6	80	50	5LGA	16	50	-	-
	IC0JLF230050652	30	24	22,5	1,5-3-6-12	15	1,5-3-6-12	80	50	5LGA	17	50	-	-
	IC0JLF238050652	38	31	28,5	1,5-3-2x6-12	19	1,5-3-2x6-12	80	50	5LGA	20	50	-	-
	IC0JLF244050652	44	36	33	3-6-2x12	11	3-6-2x12	100	50	5LGA	22	50	-	-
	IC0JLF252050652	52	42	39	3-6-12-18	13	3-2x6-2x12	100	50	5LGA	24	50	-	-
	IC0JLF260050652	60	49	45	3-6-12-24	15	3-6-3x12	100	50	5LGA	26	50	-	-
MINImatic	IC0JLF272050652	72	58	54	6-2x12-24	9	6-4x12	125	50	5LGA	29	50	-	-
	IF0JLF280050652	80	65	60	6-12-18-24	10	60	250	9	5LGA	41	55	-	60
	IF0JLF311250652	112	91	84	6-12-18-2x24	14	24-60	250	9	5LGA	47	56	-	60
	IF0JLF313650652	136	110	102	6-12-18-24-42	17	42-60	250	9	5LGA	51	56	-	60
	IF0JLF316050652	160	130	120	12-24-36-48	10	2x60	315	9	5LGA	54	56	-	60
	IF0JLF319250652	192	155	144	12-24-48-60	12	24-2x60	315	9	5LGA	60	57	-	60
	IF0JLF321650652	216	168	156	12-24-48-72	13	42-2x60	400	9	5LGA	65	57	-	60
MIDImatic	IF0JLF324050652	240	194	180	12-24-48-96	15	3x60	400	9	5LGA	69	57	-	60
	IF0JLF327250652	272	220	204	24-2x48-84	8	24-3x60	500	9	5LGA	74	58	-	61
	IL0ULF332050884	320	259	240	2x24-4x48	10	2x120	630	25	8LGA	230	64	-	-
	IL0ULF340050884	400	324	300	2x30-4x60	10	60-2x120	800	30	8LGA	250	64	-	-
	IL0ULF348050884	480	389	360	2x36-4x72	10	3x120	800	30	8LGA	280	64	-	-
	INONLF332050700	320	259	240	2x24-4x48	10	2x120	630	25	8BGA	252	-	72	75
	INONLF340050700	400	324	300	2x30-4x60	10	60-2x120	800	50	8BGA	274	-	72	75
MULTImatic	INONLF348050700	480	389	360	2x36-4x72	10	3x120	800	50	8BGA	300	-	72	75
	INONLF356050700	560	454	420	2x42-4x84	10	60-3x120	1250	50	8BGA	320	-	74	81
	INONLF364050700	640	518	480	2x48-4x96	10	4x120	1250	50	8BGA	340	-	74	81
	INONLF372050700	720	583	540	2x54-4x108	10	60-4x120	1250	50	8BGA	526	-	70	73
	INONLF380050700	800	648	600	2x60-4x120	10	5x120	2x800	50	8BGA	552	-	92	83
	INONLF388050700	880	713	660	2x66-4x132	10	60-5x120	2x800	50	8BGA	574	-	92	83
	INONLF396050700	960	778	720	2x72-4x144	10	6x120	2x800	50	8BGA	600	-	92	83
	INONLF410450700	1040	842	780	2x78-4x156	10	60-6x120	2x1250	50	8BGA	620	-	94	85
	INONLF411250700	1120	907	840	2x84-4x168	10	7x120	2x1250	50	8BGA	640	-	94	85
	INONLF412050700	1200	972	900	2x90-4x180	10	60-7x120	2x1250	50	8BGA	670	-	94	85
INONLF412850700	1280	1037	960	2x96-4x192	10	8x120	2x1250	50	8BGA	690	-	94	85	
INONLF413650700	1360	1102	1020	2x102-4x204	10	60-8x120	2x1250	50	8BGA	710	-	90	93	
INONLF414450700	1440	1166	1080	2x108-4x216	10	2x60-8x120	2x1250	50	8BGA	730	-	90	93	

1. MULTImatic of several columns have a disconnecter and a cable entry for each column.

2. Other values upon request. For MICROmatic and MIDImatic series short-circuit withstand current conditioned by the upstream protective device.

3. For part numbers contact ORTEA SpA.

HP20

Racks

MICROrack - MINIRack - MULTIRack

U _e	U _N	U _{MAX} *	f	THDI _R %	THDI _C %**
400-415V	460V	500V	50Hz	≤20%	≤70%

* Maximum admissible value according to IEC 60831-1.

** Attention: in this conditions of load network harmonic amplification phenomena is possible.

Generalities

- Special contactors with damping resistors to limit capacitors inrush current (AC6b).
- FS17 450/750V self-extinguish cable according to EN 50525 - EN 50575 - EN 50575/A1.
- Fuses with high breaking power NH00-gG.
- CRM25 single phase self-healing metallized polypropylene capacitor with U_N=460V rated voltage.
- Discharge devices.

Racks can be used as spare parts in ICAR power factor correction systems properly maintained and in suitably ventilated / conditioned third-party electrical panels (max internal temperature 55°C).

MULTI-rack can also be used on MIDImatic systems from the production date 1st of June, 2016.

Technical characteristics

Rated operational voltage	U _e =400-415V
Rated frequency	50Hz
Max current overload I_n (rack)	1,3 I _n
Max current overload I_n (capacitors @40°C)	1,3 I _n (continuous) 2 I _n (x380s every 60 minutes) 3 I _n (x150s every 60 minutes) 4 I _n (x70s every 60 minutes) 5 I _n (x45s every 60 minutes)
Max overload V_n (rack)	1,1xU _e
Max overload V_n (capacitors)	3xU _N (for 1 minute)
Insulation voltage	690V
Temperature class (rack)	-5/+40°C
Temperature class (capacitors)	-25/+55°C
Discharge device	mounted on each bank
Installation	indoor
Service	continuous
Internal connection	delta
Total losses	~ 2W/kvar
Inner surface finish	zinc passivation
Standards (rack)	IEC 61439-1/2, IEC 61921
Standards (capacitors)	IEC 60831-1/2

	Part number	Power [kvar]			Steps U _e =400V	Weight	Dimensions
		U _N =460V	U _e =415V	U _e =400V	[kvar]	[kg]	(see chap. 5)
MICRO rack	IC1JLK120050000	2	1.6	1.5	1.5	1.7	109
	IC1JLK140050000	4	3.2	3	3	2	109
	IC1JLK180050000	8	6.5	6	6	2	109
	IC1JLK216050000	16	13	12	12	2.3	109
MINI rack	IW0JLK216050000	16	13	12	12	4	110
	IW0JLK232050000	32	26	24	24	6	110
	IW0JLK256050000	56	45	42	18-24	11	110
	IW0JLK280050268	80	65	60	12-2x24	13	110
	IW0JLK280050000	80	65	60	6-12-18-24	14	110
	IX0NLK280050000	80	65	60	2x6-4x12	19	120
MULTI rack	IX0NLK316050000	160	129	120	2x12-4x24	27	120



HP30

Fix PFC system SUPERriphaso

U _e	U _N	U _{MAX} *	f	THDI _R %	THDI _C %**
400-415V	550V	600V	50Hz	≤27%	≤85%

* Maximum admissible value according to IEC 60831-1.

** Attention: in this conditions of load network harmonic amplification phenomena is possible.

Generalities

- Self-extinguishing plastic enclosure painted with epossidic dust paint, colour RAL7030.
- IP40 protection degree.
- CRM25 single phase self-healing metallized polypropylene capacitor with U_N=550V rated voltage.
- Discharge resistance.
- SUPERriphaso HP30 modules can be combined, with the mechanical and electrical connection elements supplied, to make monoblocks of up to 5 units (50kvar to 415V).

Technical characteristics

Rated operational voltage	U _e =400-415V
Rated frequency	50Hz
Max current overload I_n (capacitors @40°C)	1,3 I _n (continuous) 2 I _n (x380s every 60 minutes) 3 I _n (x150s every 60 minutes) 4 I _n (x70s every 60 minutes) 5 I _n (x45s every 60 minutes)
Max overload V_n	3xU _N (for 1 minute)
Insulation voltage	3/8kV - U _e ≤ 660V
Temperature class	-25/+55°C
Discharge device	mounted on each bank
Installation	indoor
Service	continuous
Internal connection	delta
Total losses	~ 0,4W/kvar
Standards	IEC 60831-1/2

Part number	Power [kvar]			Modules [Nr.]	Weight [kg]	Dimensions IP40 (see chap. 5)
	U _N =550V	U _e =415V	U _e =400V			
IA3DRK182550001	8,25	5	4.4	1	1.7	21
IA3DRK216550001	16,5	10	8.8	1	2.1	21

HP30

Automatic PFC system MINImatic - MULTImatic

U _e	U _N	U _{MAX} *	f	THDI _R %	THDI _C %**
400-415V	550V	600V	50Hz	≤27%	≤85%

* Maximum admissible value according to IEC 60831-1.

** Attention: in this conditions of load network harmonic amplification phenomena is possible.

Generalities

- Zink-passivated metallic enclosure painted with epossidic dust paint, colour RAL 7035.
- Auxiliary transformer to separate power and auxiliary circuit parts (110V).
- Load-break switch with door interlock.
- Special contactors with damping resistors to limit capacitors inrush current (AC6b).
- FS17 450/750V self-extinguish cable according to EN 50525 - EN 50575 - EN 50575/A1.
- Microprocessor Power Factor Correction relay.
- CRM25 single phase self-healing metallized polypropylene capacitor with U_N=550V rated voltage.

Technical characteristics

Rated operational voltage	U _e =400-415V
Rated frequency	50Hz
Max current overload I _n (bank)	1,3 I _n 1,3 I _n (continuous) 2 I _n (x380s every 60 minutes) 3 I _n (x150s every 60 minutes) 4 I _n (x70s every 60 minutes) 5 I _n (x45s every 60 minutes)
Max current overload I _n (capacitors @40°C)	
Max overload V _n (bank)	1,1xU _e
Max overload V _n (capacitors)	3xU _N (for 1 minute)
Insulation voltage	690V
Temperature class (bank)	-5/+40°C
Temperature class (capacitors)	-25/+55°C
Discharge device	mounted on each bank
Installation	indoor
Service	continuous
Internal connection	delta
Operation devices	capacitors contactors (AC6b)
Total losses	~ 2W/kvar
Inner surface finish	zinc passivation
Standards (bank)	IEC 61439-1/2, IEC 61921
Standards (capacitors)	IEC 60831-1/2

	Part number	Power [kvar]			Steps U _e =400V	Electrical steps number	Banks	LBS ¹	I _{cc} ²	PFC relay	Weight [kg]	Dimensions (see chap. 5)		
		U _N =460V	U _e =415V	U _e =400V			[kvar]	[A]	[kA]			IP3X	IP4X	IP55 ³
MINImatic	IF0TRF280050652	80	49	45	4,5-9-13,5-18	10	45	125	9	5LGA	41	55	-	60
	IF0TRF311250652	112	68	63	4,5-9-13,5-2x18	14	18-45	125	9	5LGA	47	56	-	60
	IF0TRF313650652	136	82	76	4,5-9-13,5-18-31,5	17	32-45	250	9	5LGA	51	56	-	60
	IF0TRF316050652	160	97	90	9-18-27-36	10	2x45	250	9	5LGA	54	56	-	60
	IF0TRF319250652	192	117	108	9-18-36-45	12	18-2x45	250	9	5LGA	60	57	-	60
	IF0TRF321650652	216	126	117	9-18-36-54	13	32-2x45	315	9	5LGA	65	57	-	60
	IF0TRF324050652	240	146	135	9-18-36-72	15	3x45	315	9	5LGA	69	57	-	60
	IF0TRF327250652	272	165	153	18-2x36-63	8	18-3x45	400	9	5LGA	78	58	-	61
	IF0TRF332050652	320	194	180	18-36-54-72	10	4x45	400	9	5LGA	88	58	-	61
	IN2DRF332050700	320	194	180	2x18-4x36	10	2x90	400	25	8BGA	252	-	72	75
IN2DRF340050700	400	243	225	2x22,5-4x45	10	45-2x90	630	25	8BGA	274	-	72	75	
IN2DRF348050700	480	292	270	2x27-4x54	10	3x90	630	25	8BGA	300	-	72	75	
IN2DRF356050700	560	340	315	2x31,5-4x63	10	45-3x90	800	50	8BGA	320	-	74	81	
IN2DRF364050700	640	389	360	2x36-4x72	10	4x90	800	50	8BGA	340	-	74	81	
IN2DRF372050700	720	437	405	2x40,5-4x81	10	45-4x90	1250	50	8BGA	526	-	70	73	
IN2DRF380050700	800	486	450	2x45-4x90	10	5x90	1250	50	8BGA	552	-	70	73	
IN2DRF388050700	880	535	495	2x49,5-4x99	10	45-5x90	1250	50	8BGA	574	-	71	78	
IN2DRF396050700	960	583	540	2x54-4x108	10	6x90	1250	50	8BGA	600	-	71	78	
IN2DRF410450700	1040	632	585	2x58,5-4x117	10	45-6x90	2x800	50	8BGA	620	-	94	85	
IN2DRF411250700	1120	680	630	2x63-4x126	10	7x90	2x800	50	8BGA	640	-	94	85	
IN2DRF412050700	1200	729	675	2x67,5-4x135	10	45-7x90	2x800	50	8BGA	660	-	94	85	
IN2DRF412850700	1280	778	720	2x72-4x144	10	8x90	2x800	50	8BGA	680	-	94	85	
IN2DRF413650700	1360	826	765	2x76,5-4x153	10	45-8x90	2x1250	50	8BGA	705	-	90	93	
IN2DRF414450700	1440	875	810	2x81-4x162	10	9x90	2x1250	50	8BGA	730	-	90	93	
IN2DRF415250700	1520	923	855	2x85,5-4x171	10	45-9x90	2x1250	50	8BGA	755	-	90	93	
IN2DRF416050700	1600	972	900	2x90-4x180	10	10x90	2x1250	50	8BGA	780	-	90	93	
IN2DRF416850700	1680	1021	945	2x94,5-4x189	10	45-10x90	2x1250	50	8BGA	805	-	91	98	
IN2DRF417650700	1760	1069	990	2x99-4x198	10	11x90	2x1250	50	8BGA	830	-	91	98	
IN2DRF418450700	1840	1118	1035	2x103,5-4x207	10	45-11x90	2x1250	50	8BGA	855	-	91	98	
IN2DRF419250700	1920	1166	1080	2x108-4x216	10	12x90	2x1250	50	8BGA	880	-	91	98	

1. MULTImatic of several columns have a disconnecter and a cable entry for each column.

2. Other values upon request. For MICROmatic and MIDImatic series short-circuit withstand current conditioned by the upstream protective device.

3. For part numbers contact ORTEA SpA.

HP30

Racks

MINIrack - MULTIrack

U _e	U _N	U _{MAX} *	f	THDI _R %	THDI _C %**
400-415V	550V	600V	50Hz	≤27%	≤85%

* Massimo valore ammissibile secondo IEC 60831-1.

* Maximum admissible value according to IEC 60831-1.

** Attention: in this conditions of load network harmonic amplification phenomena is possible.

Generalities

- Special contactors with damping resistors to limit capacitors inrush current (AC6b).
- FS17 450/750V self-extinguish cable according to EN 50525 - EN 50575 - EN 50575/A1.
- Fuses with high breaking power NH00-gG.
- CRM25 single phase self-healing metallized polypropylene capacitor with U_N=550V rated voltage.
- Discharge devices.

Racks can be used as spare parts in ICAR power factor correction systems properly maintained and in suitably ventilated / conditioned third-party electrical panels (max internal temperature 55°C).

Technical characteristics

Rated operational voltage	U _e =400-415V
Rated frequency	50Hz
Max current overload I_n (rack)	1,3 I _n 1,3 I _n (continuous) 2 I _n (x380s every 60 minutes) 3 I _n (x150s every 60 minutes) 4 I _n (x70s every 60 minutes) 5 I _n (x45s every 60 minutes)
Max current overload I_n (capacitors @40°C)	
Max overload V_n (rack)	1,1xU _e
Max overload V_n (capacitors)	3xU _N (for 1 minute)
Insulation voltage	690V
Temperature class (rack)	-5/+40°C
Temperature class (capacitors)	-25/+55°C
Discharge device	mounted on each bank
Installation	indoor
Service	continuous
Internal connection	delta
Total losses	~ 2W/kvar
Inner surface finish	zinc passivation
Standards (rack)	IEC 61439-1/2, IEC 61921
Standards (capacitors)	IEC 60831-1/2

	Part number	Power [kvar]			Steps U _e =400V	Weight	Dimensions
		U _N =460V	U _e =415V	U _e =400V	[kvar]	[kg]	(see chap. 5)
MINI rack	IW0SRK216050000	16	9,5	9	9	4	110
	IW0SRK232050000	32	19	18	18	6	110
	IW0SRK256050000	56	34	32	14-18	11	110
	IW0SRK280050268	80	47	45	9-2x18	13	110
	IW0SRK280050000	80	47	45	4.5-9-14-18	14	110
MULTI rack	IX2DRK280050000	80	47	45	2x4.5-4x9	19	120
	IX2DRK316050000	160	95	90	2x9-4x18	27	120

FH20

Detuned fix PFC system MICROfix

U _e	U _N	U _{MAX} *	f	THDI _R %	I _{250Hz} %**	THDV _R %	f _D
400-415V	550V	600V	50Hz	100%	≤25%	≤6%	180Hz

* Maximum admissible value according to IEC 60831-1.

** Percent current of 5th harmonic.

Generalities

- Zink-passivated metallic enclosure painted with epossidic dust paint, colour RAL 7035.
- Load-break switch with door interlock.
- Fuses with high breaking power NH00-gG.
- FS17 450/750V self-extinguish cable according to EN 50525 - EN 50575 - EN 50575/A1.
- IP3X protection degree.
- CRM25 single phase self-healing metallized polypropylene capacitor with U_N=550V rated voltage.
- Discharge resistance.
- Three phase detuning choke with tuning frequency f_D=180Hz (N=3.6-p%=7.7%).

Technical characteristics

Rated operational voltage	U _e =400-415V
Rated frequency	50Hz
Max current overload I_n (bank)	1,3 I _n 1,3 I _n (continuous) 2 I _n (x380s every 60 minutes) 3 I _n (x150s every 60 minutes) 4 I _n (x70s every 60 minutes) 5 I _n (x45s every 60 minutes)
Max current overload I_n (capacitors @40°C)	
Max overload V_n (bank)	1,1xU _e
Max overload V_n (capacitors)	3xU _N (for 1 minute)
Insulation voltage	690V
Temperature class (bank)	-5/+40°C
Temperature class (capacitors)	-25/+55°C
Discharge device	mounted on each bank
Installation	indoor
Service	continuous
Internal connection	delta
Total losses	~ 6W/kvar
Inner surface finish	zinc passivation
Standards (bank)	IEC 61439-1/2, IEC 61921
Standards (capacitors)	IEC 60831-1/2

	Part number	Power [kvar]		LBS [A]	I _{cc} ¹ [kA]	Weight [kg]	Dimensions (see chap. 5)
		U _e =415V	U _e =400V				
MICROfix	IB4FFK212550988	13,5	12,5	40	50	30	45
	IB4FFK225050988	27	25	80	50	36	45
	IB4FFK250050988	54	50	125	50	41	45
	IB4FFK275050988	81	75	250	50	54	45

1. Other values upon request. Short-circuit withstand current conditioned by the upstream protective device.



Detuned automatic PFC system MINImatic - MIDImatic - MULTImatic

U _e	U _N	U _{MAX} *	f	THDI _R %	I _{250Hz} %**	THDV _R %	f _D
400-415V	550V	600V	50Hz	100%	≤25%	≤6%	180Hz

* Maximum admissible value according to IEC 60831-1.

** Percent current of 5th harmonic.

Generalities

- Zink-passivated metallic enclosure painted with epossidic dust paint, colour RAL 7035.
- Auxiliary transformer to separate power and auxiliary circuit parts (110V).
- Load-break switch with door interlock.
- Contactors for capacitive loads.
- FS17 450/750V self-extinguish cable according to EN 50525 - EN 50575 - EN 50575/A1.
- Microprocessor Power Factor Correction relay.
- Control and protection multimeter MCP5, integrated in 8BGA controller (MIDImatic and MULTImatic version).
- CRM25 single phase self-healing metallized polypropylene capacitor with U_N=550V rated voltage.
- Three phase detuning choke with tuning frequency f_D=180Hz (N=3.6-p%=7.7%).

The MULTImatic version is also available in the /S version thyristor switched for fast changing loads and / or where high noise is required.

Technical characteristics

Rated operational voltage	U _e =400-415V
Rated frequency	50Hz
Max current overload In (bank)	1,3 In
	1,3 In (continuous)
	2 In (x380s every 60 minutes)
	3 In (x150s every 60 minutes)
	4 In (x70s every 60 minutes)
	5 In (x45s every 60 minutes)
Max current overload In (capacitors @40°C)	
Max overload Vn (bank)	1,1xU _e
Max overload Vn (capacitors)	3xU _N (for 1 minute)
Insulation voltage	690V
Temperature class (bank)	-5/+40°C
Temperature class (capacitors)	-25/+55°C
Discharge device	mounted on each bank
Installation	indoor
Service	continuous
Internal connection	delta
Total losses	~ 6W/kvar
Inner surface finish	zinc passivation
Standards (bank)	IEC 61439-1/2, IEC 61921
Standards (capacitors)	IEC 60831-1/2

	Part number	Power [kvar]		Steps U _e =400V	Electrical steps number	Banks [kvar]	LBS ¹ [A]	I _{cc} ² [kA]	PFC relay	Weight [kg]	Dimensions (see chap. 5)		
		U _e =415V	U _e =400V								IP3X	IP4X	IP55 ³
MINImatic	IF7AFF210050662	11	10	2x2.5-5	4	2x5	125	9	5LGA	41	56	-	60
	IF7AFF220050662	21	20	2x2.5-5-10	8	5-15	125	9	5LGA	47	56	-	60
	IF7AFF230050662	31	30	2x5-2x10	6	2x15	125	9	5LGA	57	56	-	60
	IF7AFF240050662	42	40	2x5-10-20	8	2x10-20	125	9	5LGA	74	57	-	60
	IF7AFF250050662	52	50	2x5-2x10-20	10	10-2x20	125	9	5LGA	78	57	-	60
	IF7AFF260050662	62	60	2x10-2x20	6	3x20	250	9	5LGA	100	57	-	60
	IF7AFF270050662	73	70	10-3x20	7	10-3x20	250	9	5LGA	112	58	-	61
MIDImatic	IL4FFF280050662	83	80	2x10-3x20	8	4x20	250	9	5LGA	126	58	-	61
	IL4FFF311050892	116	110	10-20-2x40	11	50-60	250	15	8BGA	205	64	-	-
	IL4FFF315050892	158	150	10-20-3x40	15	40-50-60	400	20	8BGA	245	64	-	-
	IL4FFF318050892	194	180	20-2x40-80	9	40-60-80	400	20	8BGA	285	64	-	-
MULTImatic	IL4FFF322050892	235	220	20-40-2x80	11	60-2x80	630	20	8BGA	300	64	-	-
	IN7AFF310050701	107	100	20-2x40	5	40-60	250	17	8BGA	220	-	72	75
	IN7AFF314050701	150	140	20-40-80	7	60-80	400	25	8BGA	260	-	72	75
	IN7AFF318050701	194	180	20-2x40-80	9	40-60-80	400	25	8BGA	300	-	72	75
	IN7AFF322050701	235	220	20-40-2x80	11	60-2x80	630	25	8BGA	325	-	72	75
	IN7AFF326050701	278	260	20-2x40-2x80	13	40-60-2x80	630	25	8BGA	365	-	74	82
	IN7AFF330050701	321	300	20-40-3x80	15	60-3x80	800	50	8BGA	385	-	74	82
	IN7AFF334050701	364	340	20-2x40-3x80	17	40-60-3x80	800	50	8BGA	415	-	70	76
	IN7AFF338050701	407	380	20-40-4x80	19	60-4x80	1250	50	8BGA	445	-	70	76
	IN7AFF342050701	450	420	20-2x40-2x80-160	21	40-60-4x80	1250	50	8BGA	475	-	71	77
	IN7AFF346050701	492	460	20-40-3x80-160	23	60-5x80	1250	50	8BGA	505	-	71	77
	IN7AFF350050701	535	500	20-2x40-80-2x160	25	40-60-5x80	2x630	25	8BGA	775	-	94	86
	IN7AFF356050701	600	560	80-3x160	7	7x80	2x800	50	8BGA	800	-	94	86
	IN7AFF364050701	685	640	2x80-3x160	8	8x80	2x800	50	8BGA	860	-	94	86
	IN7AFF372050701	770	720	80-4x160	9	9x80	2x1250	50	8BGA	920	-	90	96
IN7AFF380050701	856	800	2x80-4x160	10	10x80	2x1250	50	8BGA	980	-	90	96	
IN7AFF388050701	942	880	80-5x160	11	11x80	2x1250	50	8BGA	1040	-	91	95	
IN7AFF396050701	1027	960	2x80-3x160-320	12	12x80	2x1250	50	8BGA	1100	-	91	95	

1. MULTImatic of several columns have a disconnecter and a cable entry for each column.

2. Other values upon request. For MICROMatic and MIDImatic series short-circuit withstand current conditioned by the upstream protective device.

3. For part numbers contact ORTEA SpA.

FH20

Detuned racks MINIrack - MULTIrack

U _e	U _N	U _{MAX} *	f	THDI _R %	I _{250Hz} %**	THDV _R %	f _D
400-415V	550V	600V	50Hz	100%	≤25%	≤6%	180Hz

* Maximum admissible value according to IEC 60831-1.

** Percent current of 5th harmonic.

Generalities

- Contactors for capacitive loads.
- FS17 450/750V self-extinguish cable according to EN 50525 - EN 50575 - EN 50575/A1.
- Fuses with high breaking power NH00-gG.
- CRM25 single phase self-healing metallized polypropylene capacitor with U_N=550V rated voltage.
- Discharge devices.
- Three phase detuning choke with tuning frequency f_D=180Hz (N=3.6-p%=7.7%).

Racks can be used as spare parts in ICAR power factor correction systems properly maintained and in suitably ventilated / conditioned third-party electrical panels (max internal temperature 55°C).

MULTI-rack can also be used on MIDImatic systems from the production date 1st of June, 2016.

The MULTIrack version is also available in the /S version thyristor switched for fast changing loads and / or where high noise is required.

Technical characteristics

Rated operational voltage	U _e =400-415V
Rated frequency	50Hz
Max current overload I_n (rack)	1,3 I _n
	1,3 I _n (continuous)
	2 I _n (x380s every 60 minutes)
	3 I _n (x150s every 60 minutes)
	4 I _n (x70s every 60 minutes)
	5 I _n (x45s every 60 minutes)
Max current overload I_n (capacitors @40°C)	
Max overload V_n (rack)	1,1xU _e
Max overload V_n (capacitors)	3xU _N (for 1 minute)
Insulation voltage	690V
Temperature class (rack)	-5/+40°C
Temperature class (capacitors)	-25/+55°C
Discharge device	mounted on each bank
Installation	indoor
Service	continuous
Internal connection	delta
Total losses	~ 6W/kvar
Inner surface finish	zinc passivation
Standards (rack)	IEC 61439-1/2, IEC 61921
Standards (capacitors)	IEC 60831-1/2

	Part number	Power [kvar]		Steps U _e =400V	Weight	Dimensions
		U _e =415V	U _e =400V	[kvar]	[kg]	(see chap. 5)
MINI rack	IW7TFK155050010	5,5	5	2x2.5	14	135
	IW7TFK210050274	11	10	2x5	19	135
	IW7TFK210050010	11	10	10	15	135
	IW7TFK215050010	16	15	5-10	22	135
	IW7TFK220050248	21	20	2x10	24	135
	IW7TFK220050010	21	20	20	20	135
MULTI rack	IX7TFF220050010	21	20	20	25	130
	IX7TFF240050010	42	40	40	38	130
	Contattateci	53	50	10-40	56	130
	IX7TFF260050010	63	60	20-40	63	130
	IX7TFF280050010	84	80	80	54	130



Detuned automatic PFC system MINImatic - MULTImatic

U _e	U _N	U _{MAX} *	f	THD _{I_R} %	I _{250Hz} %**	THD _{V_R} %	f _D
400-415V	550V	600V	50Hz	100%	>25%	≤6%	135Hz

* Maximum admissible value according to IEC 60831-1.

** Percent current of 5th harmonic.

Generalities

- Zink-passivated metallic enclosure painted with epossidic dust paint, colour RAL 7035.
- Auxiliary transformer to separate power and auxiliary circuit parts (110V).
- Load-break switch with door interlock.
- Contactors for capacitive loads.
- FS17 450/750V self-extinguish cable according to EN 50525 - EN 50575 - EN 50575/A1.
- Microprocessor Power Factor Correction relay.
- Control and protection multimeter MCP5, integrated in 8BGA controller (MULTImatic version).
- CRM25 single phase self-healing metallized polypropylene capacitor with U_N=550V rated voltage.
- Three phase detuning choke with tuning frequency f_D=135Hz (N=2.7-p%=13.7%)

The MULTImatic version is also available in the /S version thyristor switched for fast changing loads and / or where high noise is required.

Technical characteristics

Rated operational voltage	U _e =400-415V
Rated frequency	50Hz
Max current overload I_n (bank)	1,3 I _n 1,3 I _n (continuous) 2 I _n (x380s every 60 minutes) 3 I _n (x150s every 60 minutes) 4 I _n (x70s every 60 minutes) 5 I _n (x45s every 60 minutes)
Max current overload I_n (capacitors @40°C)	
Max overload V_n (bank)	1,1xU _e
Max overload V_n (capacitors)	3xU _N (for 1 minute)
Insulation voltage	690V
Temperature class (bank)	-5/+40°C
Temperature class (capacitors)	-25/+55°C
Discharge device	mounted on each bank
Installation	indoor
Service	continuous
Internal connection	delta
Total losses	~ 8W/kvar
Inner surface finish	zinc passivation
Standards (bank)	IEC 61439-1/2, IEC 61921
Standards (capacitors)	IEC 60831-1/2

	Part number	Power [kvar]		Steps U _e =400V	Electrical steps number	Banks [kvar]	LBS ¹ [A]	I _{cc} ² [kA]	PFC relay	Weight [kg]	Dimensions (see chap. 5)		
		U _e =415V	U _e =400V								IP3X	IP4X	IP55 ³
MINImatic	IF7JFF210050671	11	10	2x2.5-5	4	2x5	125	9	5LGA	41	56	-	60
	IF7JFF220050671	21	20	2x2.5-5-10	8	5-15	125	9	5LGA	47	56	-	60
	IF7JFF230050671	31	30	2x5-2x10	6	2x15	125	9	5LGA	57	56	-	60
	IF7JFF240050671	42	40	2x5-10-20	8	2x10-20	125	9	5LGA	74	57	-	60
	IF7JFF250050671	52	50	2x5-2x10-20	10	3x10-20	125	9	5LGA	78	58	-	61
	IF7JFF260050671	62	60	2x10-2x20	6	2x10-2x20	250	9	5LGA	100	58	-	61
	IF7JFF270050671	73	70	10-3x20	7	10-3x20	250	9	5LGA	112	58	-	61
	IN7JFF310050702	107	100	20-2x40	5	40-60	250	17	8BGA	220	-	72	75
	IN7JFF314050702	150	140	20-40-80	7	60-80	400	25	8BGA	260	-	72	75
	IN7JFF318050702	194	180	20-2x40-80	9	40-60-80	400	25	8BGA	300	-	72	75
MULTImatic	IN7JFF322050702	235	220	20-40-2x80	11	60-2x80	630	25	8BGA	325	-	72	75
	IN7JFF326050702	278	260	20-2x40-2x80	13	40-60-2x80	630	25	8BGA	365	-	74	82
	IN7JFF330050702	321	300	20-40-3x80	15	60-3x80	800	50	8BGA	385	-	74	82
	IN7JFF334050702	364	340	20-2x40-3x80	17	40-60-3x80	800	50	8BGA	415	-	70	76
	IN7JFF338050702	407	380	20-40-4x80	19	60-4x80	1250	50	8BGA	445	-	70	76
	IN7JFF342050702	450	420	20-2x40-2x80-160	21	40-60-4x80	1250	50	8BGA	475	-	71	77
	IN7JFF346050702	492	460	20-40-3x80-160	23	60-5x80	1250	50	8BGA	505	-	71	77
	IN7JFF350050702	535	500	20-2x40-80-2x160	25	40-60-5x80	2x630	25	8BGA	775	-	94	86
	IN7JFF356050702	600	560	80-3x160	7	7x80	2x800	50	8BGA	800	-	94	86
	IN7JFF364050702	685	640	2x80-3x160	8	8x80	2x800	50	8BGA	860	-	94	86
IN7JFF372050702	770	720	80-4x160	9	9x80	2x1250	50	8BGA	920	-	90	96	
IN7JFF380050702	856	800	2x80-4x160	10	10x80	2x1250	50	8BGA	980	-	90	96	
IN7JFF388050702	942	880	80-5x160	11	11x80	2x1250	50	8BGA	1040	-	91	95	
IN7JFF396050702	1027	960	2x80-3x160-320	12	12x80	2x1250	50	8BGA	1100	-	91	95	

1. MULTImatic of several columns have a disconnector and a cable entry for each column.

2. Other values upon request.

3. For part numbers contact ORTEA SpA.

FH30

Detuned racks MINItrack - MULTItrack

U _e	U _N	U _{MAX} *	f	THDI _R %	I _{250Hz} %**	THDV _R %	f _D
400-415V	550V	600V	50Hz	100%	>25%	≤6%	135Hz

* Maximum admissible value according to IEC 60831-1.

** Percent current of 5th harmonic.

Generalities

- Contactors for capacitive loads.
- FS17 450/750V self-extinguish cable according to EN 50525 - EN 50575 - EN 50575/A1.
- Fuses with high breaking power NH00-gG.
- CRM25 single phase self-healing metallized polypropylene capacitor with U_N=550V rated voltage.
- Discharge devices.
- Three phase detuning choke with tuning frequency f_D=135Hz (N=2.7-p%=13.7%)

Racks can be used as spare parts in ICAR power factor correction systems properly maintained and in suitably ventilated / conditioned third-party electrical panels (max internal temperature 55°C).

The MULTItrack version is also available in the /S version thyristor switched for fast changing loads and / or where high noise is required.

Technical characteristics

Rated operational voltage	U _e =400-415V
Rated frequency	50Hz
Max current overload I_n (rack)	1,3 I _n
Max current overload I_n (capacitors @40°C)	1,3 I _n (continuous) 2 I _n (x380s every 60 minutes) 3 I _n (x150s every 60 minutes) 4 I _n (x70s every 60 minutes) 5 I _n (x45s every 60 minutes)
Max overload V_n (rack)	1,1xU _e
Max overload V_n (capacitors)	3xU _N (for 1 minute)
Insulation voltage	690V
Temperature class (rack)	-5/+40°C
Temperature class (capacitors)	-25/+55°C
Discharge device	mounted on each bank
Installation	indoor
Service	continuous
Internal connection	delta
Total losses	~ 8W/kvar
Inner surface finish	zinc passivation
Standards (rack)	IEC 61439-1/2, IEC 61921
Standards (capacitors)	IEC 60831-1/2

	Part number	Power [kvar]		Steps U _e =400V	Weight	Dimensions
		U _e =415V	U _e =400V	[kvar]	[kg]	(see chap.5)
MINI rack	IW7JFK155050009	5.5	5	2x2.5	14	135
	IW7JFK210050249	11	10	2x5	21	135
	IW7JFK210050009	11	10	10	17	135
	IW7JFK215050009	16	15	5-10	24	135
	IW7JFK220050009	21	20	20	22	135
MULTI rack	IX7JFF220050009	21	20	20	27	130
	IX7JFF240050009	42	40	40	40	130
	IX7JFF260050009	63	60	20-40	65	130
	IX7JFF280050009	84	80	80	56	130

POWER FACTOR CORRECTION SOLUTIONS WITH HIGH GRADIENT METALLIZED POLYPROPYLENE PLUS CAPACITORS



Range	Fix PFC systems	Automatic PFC systems	Racks	Nominal voltage U_e	Capacitors voltage U_N	THDI _R %	THDI _C %	$I_{250\text{Hz}}$ %	THDV _R %	f_D
VP10	✓	✓	✓	400V	400V	≤27%	≤85%	–	–	–
VP20	✓	✓	✓	400-415V	460V	≤27%	≤90%	–	–	–
FV25	✓	✓	✓	400V	460V	100%	–	≤25%	≤6%	180Hz
FV25V		✓	✓	400V	460V	100%	–	≤25%	≤8%	180Hz
FV35		✓	✓	400V	550V	100%	–	>25%	≤6%	135Hz

Used capacitor

CRM25-1



Generalities

- High gradient metallized polypropylene capacitors with increased thickness (plus).
- Metallic case with protection degree IP00.
- Internal overpressure protection system.
- Resin filling.

Technical characteristics

Rated operational voltage	U _e =400-460V
Rated frequency	50Hz
Max current overload I_n	1,3 I _n (continuous) 2 I _n (x500s every 60 minutes) 3 I _n (x180s every 60 minutes) 4 I _n (x90s every 60 minutes) 5 I _n (x50s every 60 minutes)
Max voltage overload V_n	3xU _N (for 1 minute)
Temperature class	-25/70°C
Life expectancy	100.000h
Capacitance tolerance	-5% ÷ +10%
Service	continuous
Construction type	high gradient polypropylene with increased thickness (plus)
Standards	IEC 60831-1/2

Range	Part number	Rated voltage U _N [V]	MAX voltage U _{MAX} [V]	Power [kvar]	Capacitance [μF]	Dimensions Ø x h [mm]	Weight [kg]	Pcs/box
VP10	6DCRM00250D50	400	440	2.5	50	60x140	0,5	36
VP20 FV25 FV25V	6DCRM00250B50	460	500	2.5	37	60x140	0,5	36
FV35	6DCRM00250C50	550	600	2.5	28	60x140	0,5	36
kit* VP10	ICRM25250400	400	440	2.5	50	310x70x220	1,5	3
kit* VP20	ICRM25250460	460	500	2.5	37	310x70x220	1,5	3
kit* FV35	ICRM25250550	550	600	2.5	28	310x70x220	1,5	3

* Kit consists of 3 capacitors, nuts and washers, discharge resistors.



Fix PFC system

SUPERriphaso - MICROfix

U _e	U _N	U _{MAX} *	f	THDI _R %	THDI _C %**
400V	400V	440V	50Hz	≤27%	≤85%

* Maximum admissible value according to IEC 60831-1.

** Attention: in this conditions of load network harmonic amplification phenomena is possible.

SUPERriphaso

Generalities

- Self-extinguishing plastic enclosure painted with epossidic dust paint, colour RAL7030.
- IP40 protection degree.
- CRM25 single phase self-healing metallized polypropylene capacitor with increased thickness and U_N=400V rated voltage.
- Discharge resistance.

SUPERriphaso VP10 modules can be combined, with the mechanical and electrical connection elements supplied, to make monoblocks of up to 6 units (45kvar to 400V).

Technical characteristics

Rated operational voltage	U _e =400V
Rated frequency	50Hz
Max current overload I_n (capacitors @40°C)	1,3 I _n (continuous) 2 I _n (x500s every 60 minutes) 3 I _n (x180s every 60 minutes) 4 I _n (x90s every 60 minutes) 5 I _n (x50s every 60 minutes)
Max overload V_n	3xU _N (for 1 minute)
Insulation voltage	3/8kV - U _e ≤ 660V
Temperature class	-5/+40°C
Discharge device	mounted on each bank
Installation	indoor
Service	continuous
Internal connection	delta
Total losses	~ 0,6W/kvar
Standards	IEC 60831-1/2

Part number	Power [kvar]	Modules	Weight	Dimensions IP40 (see chap. 5)
	U _e =400V	[Nr.]	[kg]	
IA3VFF175050001	7,5	1	2.1	21

MICROfix

Generalities

- Zinc-passivated metallic enclosure painted with epossidic dust paint, colour RAL 7035.
- Load-break switch with door interlock.
- Fuses with high breaking power NH00-gG.
- FS17 450/750V self-extinguish cable according to EN 50525 - EN 50575 - EN 50575/A1.
- IP3X protection degree.
- CRM25 single phase self-healing metallized polypropylene capacitor with increased thickness and U_N=400V rated voltage.
- Discharge resistance.
- Signal lamp power on.

Technical characteristics

Rated operational voltage	U _e =400V
Rated frequency	50Hz
Max current overload I_n (bank)	1,3 I _n 1,3 I _n (continuous) 2 I _n (x500s every 60 minutes) 3 I _n (x180s every 60 minutes) 4 I _n (x90s every 60 minutes) 5 I _n (x50s every 60 minutes)
Max current overload I_n (capacitors @40°C)	
Max overload V_n (bank)	1,1xU _e
Max overload V_n (capacitors)	3xU _N (for 1 minute)
Insulation voltage	690V
Temperature class (bank)	-5/+40°C
Temperature class (capacitors)	-25/+70°C
Discharge device	mounted on each bank
Installation	indoor
Service	continuous
Internal connection	delta
Total losses	~ 2W/kvar
Inner surface finish	zinc passivation
Standards (bank)	IEC 61439-1/2, IEC 61921
Standards (capacitors)	IEC 60831-1/2

Part Number	Power [kvar]	LBS	I _{cc} ¹	Weight	Dimensions IP3X (see chap. 5)
	U _e =400V	[A]	[kA]	[kg]	
IB5VFF215050987	15	40	50	12	43
IB5VFF222550987	22,5	80	50	15	44
IB5VFF230050987	30	80	50	18	44

1. Other values upon request. Short-circuit withstand current conditioned by the upstream protective device.



Automatic PFC system

MICROmatic - MINImatic - MULTImatic

U _e	U _N	U _{MAX} *	f	THDI _R %	THDI _C %**
400V	400V	440V	50Hz	≤27%	≤85%

* Maximum admissible value according to IEC 60831-1.

** Attention: in this conditions of load network harmonic amplification phenomena is possible.

Generalities

- Zink-passivated metallic enclosure painted with eposidic dust paint, colour RAL 7035.
- Auxiliary transformer to separate power and auxiliary circuit parts (110V).
- Load-break switch with door interlock.
- Special contactors with damping resistors to limit capacitors inrush current (AC6b).
- FS17 450/750V self-extinguish cable according to EN 50525 - EN 50575 - EN 50575/A1.
- Microprocessor Power Factor Correction relay.
- CRM25 single phase self-healing metallized polypropylene capacitor with increased thickness and U_N=400V rated voltage.

Technical characteristics

Rated operational voltage	U _e =400V
Rated frequency	50Hz
Max current overload I _n (bank)	1,3 I _n 1,3 I _n (continuous) 2 I _n (x500s every 60 minutes) 3 I _n (x180s every 60 minutes) 4 I _n (x90s every 60 minutes) 5 I _n (x50s every 60 minutes)
Max current overload I _n (capacitors @40°C)	
Max overload V _n (bank)	1,1xU _e
Max overload V _n (capacitors)	3xU _N (for 1 minute)
Insulation voltage	690V
Temperature class (bank)	-5/+40°C
Temperature class (capacitors)	-25/+70°C
Discharge device	mounted on each bank
Installation	indoor
Service	continuous
Internal connection	delta
Operation devices	capacitors contactors (AC6b)
Total losses	~ 2W/kvar
Inner surface finish	zinc passivation
Standards (bank)	IEC 61439-1/2, IEC 61921
Standards (capacitors)	IEC 60831-1/2

	Part number	Power [kvar]	Steps U _e =400V	Electrical steps number	Banks	LBS ¹	I _{cc} ²	PFC relay	Weight [kg]	Dimensions (see chap. 5)		
		U _e =400V			[kvar]	[A]	[kA]			IP3X	IP4X	IP55 ³
MICROmatic	IC2VFF222050652	22	2-4-2x8	11	2-4-2x8	63	50	5LGA	16	50	-	-
	IC2VFF230050652	30	2-4-8-16	15	2-4-3x8	80	50	5LGA	17	50	-	-
	IC2VFF236050652	36	4-2x8-16	9	4-4x8	100	50	5LGA	22	50	-	-
MINImatic	IF2VFF237550652	37,5	7,5-2x15	5	37,5	125	9	5LGA	81	55	-	60
	IF2VFF252550652	52,5	7,5-15-30	7	15-37,5	125	9	5LGA	84	56	-	60
	IF2VFF275050652	75	7,5-15-22,5-30	10	2x37,5	250	9	5LGA	94	56	-	60
	IF2VFF290050652	90	7,5-15-30-38	12	15-2x37,5	250	9	5LGA	106	57	-	60
	IF2VFF311250652	112,5	7,5-15-30-60	15	3x37,5	250	9	5LGA	115	57	-	60
	IF2VFF313550652	135	15-2x30-60	9	22,5-3x37,5	400	9	5LGA	126	58	-	61
MULTImatic	IF2VFF315050652	150	15-30-45-60	10	4x37,5	400	9	5LGA	132	58	-	61
	IN2VFF316550700	165	15-5x30	11	2x82,5	400	25	8BGA	240	-	72	75
	IN2VFF320650700	206	19-5x38	11	41-2x83	630	25	8BGA	280	-	72	75
	IN2VFF324850700	248	23-5x45	11	3x82,5	630	25	8BGA	300	-	72	75
	IN2VFF328950700	289	26-5x53	11	41,25-3x82,5	630	25	8BGA	340	-	74	81
	IN2VFF333050700	330	30-5x60	11	4x82,5	800	50	8BGA	360	-	74	81
	IN2VFF337150700	371	34-5x68	11	41,25-4x82,5	800	50	8BGA	400	-	70	73
	IN2VFF341350700	413	38-5x75	11	5x82,5	1250	50	8BGA	420	-	70	73
	IN2VFF345450700	454	41-5x83	11	41,25-5x82,5	1250	50	8BGA	490	-	71	78
	IN2VFF349550700	495	45-5x90	11	6x82,5	1250	50	8BGA	505	-	71	78
	IN2VFF353650700	536	49-5x98	11	41,25-6x82,5	2x630	25	8BGA	640	-	94	85
	IN2VFF357850700	578	53-5x105	11	7x82,5	2x800	50	8BGA	660	-	94	85
	IN2VFF361950700	619	56-5x113	11	41,25-7x82,5	2x800	50	8BGA	700	-	94	85
	IN2VFF366050700	660	60-5x120	11	8x82,5	2x800	50	8BGA	720	-	94	85
	IN2VFF370150700	701	64-5x128	11	41,25-8x82,5	2x800	50	8BGA	740	-	90	93
	IN2VFF374350700	743	68-5x135	11	9x82,5	2x1250	50	8BGA	760	-	90	93
	IN2VFF378450700	784	71-5x143	11	41,25-9x82,5	2x1250	50	8BGA	820	-	90	93
	IN2VFF382550700	825	75-5x150	11	10x82,5	2x1250	50	8BGA	840	-	90	93
	IN2VFF390850700	908	83-5x165	11	11x82,5	2x1250	50	8BGA	980	-	91	98
	IN2VFF399050700	990	90-5x180	11	12x82,5	2x1250	50	8BGA	1010	-	91	98

1. MULTImatic of several columns have a disconnecter and a cable entry for each column.

2. Other values upon request. For MICROmatic series short-circuit withstand current conditioned by the upstream protective device.

3. For part numbers contact ORTEA SpA.



Racks

MICROrack - MINIRack - MULTIRack

U _e	U _N	U _{MAX} *	f	THDI _R %	THDI _C %**
400V	400V	440V	50Hz	≤27%	≤85%

* Maximum admissible value according to IEC 60831-1.

** Attention: in this conditions of load network harmonic amplification phenomena is possible.

Generalities

- Special contactors with damping resistors to limit capacitors inrush current (AC6b).
- FS17 450/750V self-extinguish cable according to EN 50525 - EN 50575 - EN 50575/A1.
- Fuses with high breaking power NH00-gG.
- CRM25 single phase self-healing metallized polypropylene capacitor with increased thickness and U_N=400V rated voltage.
- Discharge devices.

Racks can be used as spare parts in ICAR power factor correction systems properly maintained and in suitably ventilated / conditioned third-party electrical panels (max internal temperature 55°C).

Technical characteristics

Rated operational voltage	U _e =400V
Rated frequency	50Hz
Max current overload I _n (rack)	1,3 I _n 1,3 I _n (continuous) 2 I _n (x500s every 60 minutes) 3 I _n (x180s every 60 minutes) 4 I _n (x90s every 60 minutes) 5 I _n (x50s every 60 minutes)
Max current overload I _n (capacitors @40°C)	
Max overload V _n (rack)	1,1xU _e
Max overload V _n (capacitors)	3xU _N (for 1 minute)
Insulation voltage	690V
Temperature class (rack)	-5/+40°C
Temperature class (capacitors)	-25/+70°C
Discharge device	mounted on each bank
Installation	indoor
Service	continuous
Internal connection	delta
Total losses	~ 2W/kvar
Inner surface finish	zinc passivation
Standards (rack)	IEC 61439-1/2, IEC 61921
Standards (capacitors)	IEC 60831-1/2

	Part number	Power [kvar]	Steps U _e =400V	Weight	Dimensions
		U _e =400V	[kvar]	[kg]	(see chap. 5)
MICRO rack	IC2LFF120050000	2	2	2	109
	IC2LFF140050000	4	4	2	109
	IC2LFF180050000	8	8	2	109
	IW2VFF175050000	7,5	7,5	10	110
MINI rack	IW2VFF215050000	15	15	11	110
	IW2VFF222550000	22,5	7,5-15	13	110
	IW2VFF230050000	30	2x15	14	110
	IW2VFF237550000	37,5	7,5-2x15	16	110
MULTI rack	IX2VFF241250000	41,25	3,75-5x7,5	19	120
	IX2VFF282550000	82,5	7,5-5x15	27	120



Fix PFC system SUPERriphaso

U _e	U _N	U _{MAX} *	f	THDI _R %	THDI _C %**
400-415V	460V	500V	50Hz	≤27%	≤90%

* Maximum admissible value according to IEC 60831-1.

** Attention: in this conditions of load network harmonic amplification phenomena is possible.

Generalities

- Self-extinguishing plastic enclosure painted with epossidic dust paint, colour RAL7030.
- IP40 protection degree.
- CRM25 single phase self-healing metallized polypropylene capacitor with increased thickness and U_N=460V rated voltage.
- Discharge resistance.

SUPERriphaso VP20 modules can be combined, with the mechanical and electrical connection elements supplied, to make monoblocks of up to 6 units (36kvar to 415V).

Technical characteristics

Rated operational voltage	U _e =400-415V
Rated frequency	50Hz
Max current overload I_n (capacitors @40°C)	1,3 I _n (continuous) 2 I _n (x500s every 60 minutes) 3 I _n (x180s every 60 minutes) 4 I _n (x90s every 60 minutes) 5 I _n (x50s every 60 minutes)
Max overload V_n	3xU _N (for 1 minute)
Insulation voltage	3/8kV - U _e ≤ 660V
Temperature class	-5/+40°C
Discharge device	mounted on each bank
Installation	indoor
Service	continuous
Internal connection	delta
Total losses	~ 0,5W/kvar
Standards	IEC 60831-1/2

Part number	Power [kvar]		Modules [Nr.]	Weight [kg]	Dimensions IP40 (see chap. 5)
	U _N =460V	U _e =400V			
IA3ZLK175050001	7.5	5.5	1	2.1	21



Automatic PFC system MINImatic - MULTImatic

U _e	U _N	U _{MAX} *	f	THDI _R %	THDI _C %**
400-415V	460V	500V	50Hz	≤27%	≤90%

* Maximum admissible value according to IEC 60831-1.

** Attention: in this conditions of load network harmonic amplification phenomena is possible.

Generalities

- Zink-passivated metallic enclosure painted with epossidic dust paint, colour RAL 7035.
- Auxiliary transformer to separate power and auxiliary circuit parts (110V).
- Load-break switch with door interlock.
- Special contactors with damping resistors to limit capacitors inrush current (AC6b).
- FS17 450/750V self-extinguish cable according to EN 50525 - EN 50575 - EN 50575/A1.
- Microprocessor Power Factor Correction relay.
- CRM25 single phase self-healing metallized polypropylene capacitor with increased thickness and U_N=460V rated voltage.

Technical characteristics

Rated operational voltage	U _e =400-415V
Rated frequency	50Hz
Max current overload I _n (bank)	1,3 I _n 1,3 I _n (continuous) 2 I _n (x500s every 60 minutes) 3 I _n (x180s every 60 minutes) 4 I _n (x90s every 60 minutes) 5 I _n (x50s every 60 minutes)
Max current overload I _n (capacitors @40°C)	
Max overload V _n (bank)	1,1xU _e
Max overload V _n (capacitors)	3xU _N (for 1 minute)
Insulation voltage	690V
Temperature class (bank)	-5/+40°C
Temperature class (capacitors)	-25/+70°C
Discharge device	mounted on each bank
Installation	indoor
Service	continuous
Internal connection	delta
Operation devices	capacitors contactors (AC6b)
Total losses	~ 2W/kvar
Inner surface finish	zinc passivation
Standards (bank)	IEC 61439-1/2, IEC 61921
Standards (capacitors)	IEC 60831-1/2

	Part number	Power [kvar]			Steps U _e =400V	Electrical steps number	Banks [kvar]	LBS ¹ [A]	I _{cc} ² [kA]	PFC relay	Weight [kg]	Dimensions (see chap. 5)		
		U _N =460V	U _e =415V	U _e =400V								IP3X	IP4X	IP55 ³
MINImatic	IF2ZLF237550652	37,5	30	28	5,6-2x11,2	5	28	125	9	5LGA	81	55	-	60
	IF2ZLF252550652	52,5	42	39	5,6-11,2-22,4	7	11-28	125	9	5LGA	84	56	-	60
	IF2ZLF275050652	75	60	56	5,6-11,2-16,8-22,4	10	2x28	250	9	5LGA	94	56	-	60
	IF2ZLF290050652	90	73	68	5,6-11,2-22,4-28	12	11-2x28	250	9	5LGA	106	57	-	60
	IF2ZLF311250652	112,5	90	84	5,6-11,2-22,4-44,8	15	3x28	250	9	5LGA	115	57	-	60
	IF2ZLF313550652	135	108	101	11,2-22,4-22,4-44,8	9	16,8-3x28	400	9	5LGA	126	58	-	61
MULTImatic	IF2ZLF315050652	150	120	112	11,2-22,4-33,6-44,8	10	4x28	400	9	5LGA	132	58	-	61
	IN2ZLF316550700	165	133	124	11-5x22	11	2x62	400	25	8BGA	240	-	72	75
	IN2ZLF320650700	206	166	155	14-5x28	11	31-2x62	400	25	8BGA	280	-	72	75
	IN2ZLF324850700	248	199	186	17-5x34	11	3x62	630	25	8BGA	300	-	72	75
	IN2ZLF328950700	289	232	217	20-5x40	11	31-3x62	630	25	8BGA	340	-	74	81
	IN2ZLF333050700	330	265	248	22,5-5x45	11	4x62	630	25	8BGA	360	-	74	81
	IN2ZLF337150700	371	297	278	25-5x50	11	31-4x62	630	25	8BGA	400	-	70	73
	IN2ZLF341350700	413	331	309	28-5x56	11	5x62	800	50	8BGA	420	-	70	73
	IN2ZLF345450700	454	364	340	31-5x62	11	31-5x62	800	50	8BGA	490	-	71	78
	IN2ZLF349550700	495	397	371	33-5x66	11	6x62	800	50	8BGA	505	-	71	78
	IN2ZLF353650700	536	430	402	36-5x72	11	31-6x62	2x630	25	8BGA	640	-	94	85
	IN2ZLF357850700	578	463	433	39-5x78	11	7x62	2x630	25	8BGA	660	-	94	85
	IN2ZLF361950700	619	496	464	42-5x84	11	31-7x62	2x630	25	8BGA	700	-	94	85
	IN2ZLF366050700	660	530	495	45-5x90	11	8x62	2x630	25	8BGA	720	-	94	85
	IN2ZLF370150700	701	563	526	48-5x96	11	31-8x62	2x630	25	8BGA	740	-	90	93
	IN2ZLF374350700	743	596	557	51-5x102	11	9x62	2x800	50	8BGA	760	-	90	93
	IN2ZLF378450700	784	628	587	53-5x106	11	31-9x62	2x800	50	8BGA	820	-	90	93
	IN2ZLF382550700	825	662	619	56-5x112	11	10x62	2x800	50	8BGA	840	-	90	93
IN2ZLF390850700	908	730	682	62-5x124	11	11x62	2x800	50	8BGA	980	-	91	98	
IN2ZLF399050700	990	796	744	67-5x134	11	12x62	2x800	50	8BGA	1010	-	91	98	

1. MULTImatic of several columns have a disconnecter and a cable entry for each column.

2. Other values upon request.

3. For part numbers contact ORTEA SpA.



Racks

MINIrack - MULTIrack

U _e	U _N	U _{MAX} *	f	THDI _R %	THDI _C %**
400-415V	460V	500V	50Hz	≤27%	≤90%

* Maximum admissible value according to IEC 60831-1.

** Attention: in this conditions of load network harmonic amplification phenomena is possible.

Generalities

- Special contactors with damping resistors to limit capacitors inrush current (AC6b).
- FS17 450/750V self-extinguish cable according to EN 50525 - EN 50575 - EN 50575/A1.
- Fuses with high breaking power NH00-gG.
- CRM25 single phase self-healing metallized polypropylene capacitor with increased thickness and U_N=460V rated voltage.
- Discharge devices.

Racks can be used as spare parts in ICAR power factor correction systems properly maintained and in suitably ventilated / conditioned third-party electrical panels (max internal temperature 55°C).

Technical characteristics

Rated operational voltage	U _e =400-415V
Rated frequency	50Hz
Max current overload I _n (rack)	1,3 I _n 1,3 I _n (continuous) 2 I _n (x500s every 60 minutes) 3 I _n (x180s every 60 minutes) 4 I _n (x90s every 60 minutes) 5 I _n (x50s every 60 minutes)
Max current overload I _n (capacitors @40°C)	
Max overload V _n (rack)	1,1xU _e
Max overload V _n (capacitors)	3xU _N (for 1 minute)
Insulation voltage	690V
Temperature class (rack)	-5/+40°C
Temperature class (capacitors)	-25/+70°C
Discharge device	mounted on each bank
Installation	indoor
Service	continuous
Internal connection	delta
Operation devices	capacitors contactors (AC6b)
Total losses	~ 2W/kvar
Inner surface finish	zinc passivation
Standards (rack)	IEC 61439-1/2, IEC 61921
Standards (capacitors)	IEC 60831-1/2

	Part number	Power [kvar]			Steps U _e =400V	Weight	Dimensions
		U _N =460V	U _e =415V	U _e =400V	[kvar]	[kg]	(see chap. 5)
MINI rack	IW2ZLF175050000	7.5	6	5.6	5.6	10	110
	IW2ZLF215050000	15	12	11.2	11.2	11	110
	IW2ZLF222550000	22.5	18	16.8	5.6-11.2	13	110
	IW2ZLF230050000	30	24	22.4	2x11.2	14	110
	IW2ZLF237550000	37.5	32	30	5.6-2x11.2	16	110
MULTI rack	IX2ZLF241250000	41.25	33	31	2.8-5x5.6	19	120
	IX2ZLF282550000	82.5	70	62	5.6-5x11.2	27	120

FV25

Detuned fix PFC system

MICROfix

U _e	U _N	U _{MAX} *	f	THDI _R %	I _{250Hz} %**	THDV _R %	f _D
400V	460V	500V	50Hz	100%	≤25%	≤6%	180Hz

* Maximum admissible value according to IEC 60831-1.

** Percent current of 5th harmonic.

Generalities

- Zink-passivated metallic enclosure painted with epossidic dust paint, colour RAL 7035.
- Load-break switch with door interlock.
- Fuses with high breaking power NH00-gG.
- FS17 450/750V self-extinguish cable according to EN 50525 - EN 50575 - EN 50575/A1.
- IP3X protection degree.
- CRM25 single phase self-healing metallized polypropylene capacitor with increased thickness and U_N=460V rated voltage.
- Discharge resistance.
- Three phase detuning choke with tuning frequency f_D=180Hz (N=3.6-p%=7.7%).

Technical characteristics

Rated operational voltage	U _e =400V
Rated frequency	50Hz
Max current overload I_n (bank)	1,3 I _n 1,3 I _n (continuous) 2 I _n (x500s every 60 minutes) 3 I _n (x180s every 60 minutes) 4 I _n (x90s every 60 minutes) 5 I _n (x50s every 60 minutes)
Max current overload I_n (capacitors @40°C)	
Max overload V_n (bank)	1,1xU _e
Max overload V_n (capacitors)	3xU _N (for 1 minute)
Insulation voltage	690V
Temperature class (bank)	-5/+40°C
Temperature class (capacitors)	-25/+70°C
Discharge device	mounted on each bank
Installation	indoor
Service	continuous
Internal connection	delta
Total losses	~ 6W/kvar
Inner surface finish	zinc passivation
Standards (bank)	IEC 61439-1/2, IEC 61921
Standards (capacitors)	IEC 60831-1/2

	Part Number	Power [kvar]	LBS	I _{cc} ¹	Weight	Dimensions
		U _e =400V	[A]	[kA]	[kg]	(see chap. 5)
MICROfix	IB5AFF212550988	12,5	40	50	30	45
	IB5AFF225050988	25	80	50	36	45
	IB5AFF250050988	50	125	50	41	45

1. Other values upon request. Short-circuit withstand current conditioned by the upstream protective device.

FV25

Detuned automatic PFC system

MULTImatic

U _e	U _N	U _{MAX} *	f	THD _{I_R} %	I _{250Hz} %**	THD _{V_R} %	f _D
400V	460V	500V	50Hz	100%	≤25%	≤6%	180Hz

* Maximum admissible value according to IEC 60831-1.

** Percent current of 5th harmonic.

Generalities

- Zink-passivated metallic enclosure painted with eposidic dust paint, colour RAL 7035.
- Auxiliary transformer to separate power and auxiliary circuit parts (110V).
- Load-break switch with door interlock.
- Contactors for capacitive loads.
- FS17 450/750V self-extinguish cable according to EN 50525 - EN 50575 - EN 50575/A1.
- Microprocessor Power Factor Correction relay.
- Control and protection multimeter MCP5, integrated in 8BGA controller.
- CRM25 single phase self-healing metallized polypropylene capacitor with increased thickness and U_N=460V rated voltage.
- Three phase detuning choke with tuning frequency f_D=180Hz (N=3.6-p%=7.7%).

Technical characteristics

Rated operational voltage	U _e =400V
Rated frequency	50Hz
Max current overload I_n (bank)	1,3 I _n 1,3 I _n (continuous) 2 I _n (x500s every 60 minutes) 3 I _n (x180s every 60 minutes) 4 I _n (x90s every 60 minutes) 5 I _n (x50s every 60 minutes)
Max current overload I_n (capacitors @40°C)	
Max overload V_n (bank)	1,1xU _e
Max overload V_n (capacitors)	3xU _N (for 1 minute)
Insulation voltage	690V
Temperature class (bank)	-5/+40°C
Temperature class (capacitors)	-25/+70°C
Discharge device	mounted on each bank
Installation	indoor
Service	continuous
Internal connection	delta
Total losses	~ 6W/kvar
Inner surface finish	zinc passivation
Standards (bank)	IEC 61439-1/2, IEC 61921
Standards (capacitors)	IEC 60831-1/2

	Part number	Power [kvar]	Steps U _e =400V	Electrical steps number	Banks	LBS ¹	I _{cc} ²	PFC relay	Weight	Dimensions (see chap. 5)	
		U _e =400V			[kvar]	[A]	[kA]		[kg]	IP4X	IP55 ³
MULTImatic	IN5VFF288050701	88	12,5-25-50	7	37,5-50	250	17	8BGA	250	72	75
	IN5VFF313850701	138	12,5-25-2x50	11	37,5-2x50	400	25	8BGA	315	72	75
	IN5VFF317550701	175	25-3x50	7	25-3x50	400	25	8BGA	380	74	81
	IN5VFF322550701	225	25-4x50	9	25-4x50	630	25	8BGA	460	70	76
	IN5VFF327550701	275	25-5x50	11	25-5x50	630	25	8BGA	520	71	77
	IN5VFF335050701	350	2x25-2x50-2x100	14	2x25-6x50	2x400	25	8BGA	740	94	85
	IN5VFF340050701	400	2x50-3x100	8	8x50	2x630	25	8BGA	800	94	85
	IN5VFF345050701	450	50-4x100	9	9x50	2x630	25	8BGA	860	90	96
	IN5VFF350050701	500	2x50-4x100	10	10x50	2x630	25	8BGA	920	90	96
	IN5VFF355050701	550	50-5x100	11	11x50	2x800	50	8BGA	980	91	95
	IN5VFF360050701	600	2x50-3x100-200	12	12x50	2x800	50	8BGA	1040	91	95
	IN5VFF365050701	650	50-4x100-200	13	13x50	3x630	25	8BGA	1330	101	103
	IN5VFF370050701	700	2x50-2x100-2x200	14	14x50	3x630	25	8BGA	1355	101	103
	IN5VFF375050701	750	50-3x100-2x200	15	15x50	3x630	25	8BGA	1380	101	103
	IN5VFF380050701	800	2x50-100-3x200	16	16x50	3x800	50	8BGA	1495	102	104
	IN5VFF385050701	850	3x50-3x100-2x200	17	17x50	3x800	50	8BGA	1525	102	104
	IN5VFF390050701	900	3x100-3x200	9	18x50	3x800	50	8BGA	1560	102	104

1. MULTImatic of several columns have a disconnecter and a cable entry for each column.

2. Other values upon request.

3. For part numbers contact ORTEA SpA.

FV25

Detuned racks MULTItrack

U _e	U _N	U _{MAX} *	f	THD _R %	I _{250Hz} %**	THDV _R %	f _D
400V	460V	500V	50Hz	100%	≤25%	≤6%	180Hz

* Maximum admissible value according to IEC 60831-1.

** Percent current of 5th harmonic.

Generalities

- Contactors for capacitive loads.
- FS17 450/750V self-extinguish cable according to EN 50525 - EN 50575 - EN 50575/A1.
- CRM25 single phase self-healing metallized polypropylene capacitor with increased thickness and U_N=460V rated voltage.
- Discharge devices.
- Three phase detuning choke with tuning frequency f_D=180Hz (N=3.6-p%=7.7%).

Racks can be used as spare parts in ICAR power factor correction systems properly maintained and in suitably ventilated / conditioned third-party electrical panels (max internal temperature 55°C).

Technical characteristics

Rated operational voltage	U _e =400V
Rated frequency	50Hz
Max current overload I_n (rack)	1,3 I _n
Max current overload I_n (capacitors @40°C)	1,3 I _n (continuous) 2 I _n (x500s every 60 minutes) 3 I _n (x180s every 60 minutes) 4 I _n (x90s every 60 minutes) 5 I _n (x50s every 60 minutes)
Max overload V_n (rack)	1,1xU _e
Max overload V_n (capacitors)	3xU _N (for 1 minute)
Insulation voltage	690V
Temperature class (rack)	-5/+40°C
Temperature class (capacitors)	-25/+70°C
Discharge device	mounted on each bank
Installation	indoor
Service	continuous
Internal connection	delta
Total losses	~ 6W/kvar
Inner surface finish	zinc passivation
Standards (rack)	IEC 61439-1/2, IEC 61921
Standards (capacitors)	IEC 60831-1/2

	Part number	Power [kvar]	Steps U _e =400V	Weight	Dimensions
		U _e =400V	[kvar]	[kg]	(see chap. 5)
MULTI rack	IX5VFF225050010	25	25	32	130
	IX5VFF237550010	37.5	12.5-25	35	130
	IX5VFF250050010	50	50	46	130

FV25V

Detuned automatic PFC system MULTImatic

U _e	U _N	U _{MAX} *	f	THDI _R %	I _{250Hz} %**	THDV _R %	f _D
400V	460V	500V	50Hz	100%	≤25%	≤8%	180Hz

* Maximum admissible value according to IEC 60831-1.

** Percent current of 5th harmonic.

Generalities

- Zink-passivated metallic enclosure painted with epossidic dust paint, colour RAL 7035.
- Auxiliary transformer to separate power and auxiliary circuit parts (110V).
- Load-break switch with door interlock.
- Contactors for capacitive loads.
- FS17 450/750V self-extinguish cable according to EN 50525 - EN 50575 - EN 50575/A1.
- Microprocessor Power Factor Correction relay.
- Control and protection multimeter MCP5, integrated in 8BGA controller.
- CRM25 single phase self-healing metallized polypropylene capacitor with increased thickness and U_N=460V rated voltage.
- High Linearity three phase copper detuning choke with tuning frequency f_D=180Hz (N=3.6-p%=7.7%).

Technical characteristics

Rated operational voltage	U _e =400V
Rated frequency	50Hz
Max current overload I_n (bank)	1,3 I _n 1,3 I _n (continuous) 2 I _n (x500s every 60 minutes) 3 I _n (x180s every 60 minutes) 4 I _n (x90s every 60 minutes) 5 I _n (x50s every 60 minutes)
Max current overload I_n (capacitors @40°C)	
Max overload V_n (bank)	1,1xU _e
Max overload V_n (capacitors)	3xU _N (for 1 minute)
Insulation voltage	690V
Temperature class (bank)	-5/+40°C
Temperature class (capacitors)	-25/+70°C
Discharge device	mounted on each bank
Installation	indoor
Service	continuous
Internal connection	delta
Total losses	~ 6W/kvar
Inner surface finish	zinc passivation
Standards (bank)	IEC 61439-1/2, IEC 61921
Standards (capacitors)	IEC 60831-1/2

	Part number	Power [kvar]	Steps U _e =400V	Electrical steps number	Banks	LBS ¹	I _{cc} ²	PFC relay	Weight	Dimensions (see chap. 5)	
		U _e =400V			[kvar]	[A]	[kA]		[kg]	IP4X	IP55 ³
MULTImatic	IN5ZFF288050703	88	12,5-25-50	7	37.5-50	250	17	8BGA	250	72	75
	IN5ZFF313850703	138	12,5-25-2x50	11	37.5-2x50	400	25	8BGA	315	72	75
	IN5ZFF317550703	175	25-3x50	7	25-3x50	400	25	8BGA	380	74	81
	IN5ZFF322550703	225	25-4x50	9	25-4x50	630	25	8BGA	460	70	76
	IN5ZFF327550703	275	25-5x50	11	25-5x50	630	25	8BGA	520	71	77
	IN5ZFF335050703	350	2x25-2x50-2x100	14	2x25-6x50	2x400	25	8BGA	740	94	85
	IN5ZFF340050703	400	2x50-3x100	8	8x50	2x630	25	8BGA	800	94	85
	IN5ZFF345050703	450	50-4x100	9	9x50	2x630	25	8BGA	860	90	96
	IN5ZFF350050703	500	2x50-4x100	10	10x50	2x630	25	8BGA	920	90	96
	IN5ZFF355050703	550	50-5x100	11	11x50	2x800	50	8BGA	980	91	95
	IN5ZFF360050703	600	2x50-3x100-200	12	12x50	2x800	50	8BGA	1040	91	95

1. MULTImatic of several columns have a disconnecter and a cable entry for each column.

2. Other values upon request.

3. For part numbers contact ORTEA SpA.

FV25V

Detuned racks MULTrack

U _e	U _N	U _{MAX} *	f	THDI _R %	I _{250Hz} %**	THDV _R %	f _D
400V	460V	500V	50Hz	100%	≤25%	≤8%	180Hz

* Maximum admissible value according to IEC 60831-1.

** Percent current of 5th harmonic.

Generalities

- Contactors for capacitive loads.
- FS17 450/750V self-extinguish cable according to EN 50525 - EN 50575 - EN 50575/A1.
- CRM25 single phase self-healing metallized polypropylene capacitor with increased thickness and U_N=460V rated voltage.
- Discharge devices.
- High Linearity three phase copper detuning choke with tuning frequency f_D=180Hz (N=3.6-p%=7.7%).

Racks can be used as spare parts in ICAR power factor correction systems properly maintained and in suitably ventilated / conditioned third-party electrical panels (max internal temperature 55°C).

Technical characteristics

Rated operational voltage	U _e =400V
Rated frequency	50Hz
Max current overload I_n (rack)	1,3 I _n
Max current overload I_n (capacitors @40°C)	1,3 I _n (continuous) 2 I _n (x500s every 60 minutes) 3 I _n (x180s every 60 minutes) 4 I _n (x90s every 60 minutes) 5 I _n (x50s every 60 minutes)
Max overload V_n (rack)	1,1xU _e
Max overload V_n (capacitors)	3xU _N (for 1 minute)
Insulation voltage	690V
Temperature class (rack)	-5/+40°C
Temperature class (capacitors)	-25/+70°C
Discharge device	mounted on each bank
Installation	indoor
Service	continuous
Internal connection	delta
Total losses	~ 6W/kvar
Inner surface finish	zinc passivation
Standards (rack)	IEC 61439-1/2, IEC 61921
Standards (capacitors)	IEC 60831-1/2

Part number	Power [kvar]	Steps U _e =400V	Weight	Dimensions
	U _e =400V	[kvar]	[kg]	(see chap. 5)
IX5ZFF250050526	50	50	46	130

FV35

Detuned automatic PFC system MULTImatic

U _e	U _N	U _{MAX} *	f	THDI _R %	I _{250Hz} %**	THDV _R %	f _D
400V	550V	600V	50Hz	100%	>25%	≤6%	135Hz

* Maximum admissible value according to IEC 60831-1.

** Percent current of 5th harmonic.

Generalities

- Zink-passivated metallic enclosure painted with epossidic dust paint, colour RAL 7035.
- Auxiliary transformer to separate power and auxiliary circuit parts (110V).
- Load-break switch with door interlock.
- Contactors for capacitive loads.
- FS17 450/750V self-extinguish cable according to EN 50525 - EN 50575 - EN 50575/A1.
- Microprocessor Power Factor Correction relay.
- Control and protection multimeter MCP5, integrated in 8BGA controller.
- CRM25 single phase self-healing metallized polypropylene capacitor with increased thickness and U_N=460V rated voltage.
- Three phase detuning choke with tuning frequency f_D=135Hz (N=2.7-p%=13.7%).

Technical characteristics

Rated operational voltage	U _e =400V
Rated frequency	50Hz
Max current overload In (bank)	1,3 In
	1,3 In (continuous)
	2 In (x500s every 60 minutes)
	3 In (x180s every 60 minutes)
	4 In (x90s every 60 minutes)
	5 In (x50s every 60 minutes)
Max current overload In (capacitors @40°C)	
Max overload Vn (bank)	1,1xU _e
Max overload Vn (capacitors)	3xU _N (for 1 minute)
Insulation voltage	690V
Temperature class (bank)	-5/+40°C
Temperature class (capacitors)	-25/+70°C
Discharge device	mounted on each bank
Installation	indoor
Service	continuous
Internal connection	delta
Total losses	~ 6W/kvar
Inner surface finish	zinc passivation
Standards (bank)	IEC 61439-1/2, IEC 61921
Standards (capacitors)	IEC 60831-1/2

	Part number	Power [kvar]	Steps U _e =400V	Electrical steps number	Banks	LBS ¹	I _{cc} ²	PFC relay	Weight	Dimensions (see chap. 5)	
		U _e =400V			[kvar]	[A]	[kA]		[kg]	IP4X	IP55 ³
MULTImatic	IN5LFF260050702	60	20-40	3	20-40	250	17	8BGA	250	72	75
	IN5LFF310050702	100	20-2x40	5	20-2x40	250	17	8BGA	315	72	75
	IN5LFF314050702	140	20-3x40	7	20-3x40	400	25	8BGA	380	74	81
	IN5LFF320050702	200	5x40	5	5x40	630	25	8BGA	460	70	76
	IN5LFF324050702	240	6x40	6	6x40	630	25	8BGA	520	71	77
	IN5LFF328050702	280	40-3x80	7	7x40	2x400	25	8BGA	740	94	85
	IN5LFF332050702	320	2x40-3x80	8	8x40	2x630	25	8BGA	800	94	85
	IN5LFF336050702	360	40-4x80	9	9x40	2x630	25	8BGA	860	90	96
	IN5LFF340050702	400	2x40-4x80	10	10x40	2x630	25	8BGA	920	90	96
	IN5LFF344050702	440	40-5x80	11	11x40	2x800	25	8BGA	980	91	95
	IN5LFF348050702	480	2x40-3x80-160	12	12x40	2x800	25	8BGA	1040	91	95

1. MULTImatic of several columns have a disconnecter and a cable entry for each column.

2. Other values upon request.

3. For part numbers contact ORTEA SpA.

FV35

Detuned racks MULTrack

U _e	U _N	U _{MAX} *	f	THDI _R %	I _{250Hz} %**	THDV _R %	f _D
400V	550V	600V	50Hz	100%	>25%	≤6%	135Hz

* Maximum admissible value according to IEC 60831-1.

** Percent current of 5th harmonic.

Generalities

- Contactors for capacitive loads.
- FS17 450/750V self-extinguish cable according to EN 50525 - EN 50575 - EN 50575/A1.
- CRM25 single phase self-healing metallized polypropylene capacitor with increased thickness and U_N=460V rated voltage.
- Discharge devices.
- Three phase detuning choke with tuning frequency f_D=135Hz (N=2.7-p%=13.7%).

Racks can be used as spare parts in ICAR power factor correction systems properly maintained and in suitably ventilated / conditioned third-party electrical panels (max internal temperature 55°C).

Technical characteristics

Rated operational voltage	U _e =400V
Rated frequency	50Hz
Max current overload I_n (rack)	1,3 I _n
	1,3 I _n (continuous)
	2 I _n (x500s every 60 minutes)
	3 I _n (x180s every 60 minutes)
	4 I _n (x90s every 60 minutes)
	5 I _n (x50s every 60 minutes)
Max current overload I_n (capacitors @40°C)	
Max overload V_n (rack)	1,1xU _e
Max overload V_n (capacitors)	3xU _N (for 1 minute)
Insulation voltage	690V
Temperature class (rack)	-5/+40°C
Temperature class (capacitors)	-25/+70°C
Discharge device	mounted on each bank
Installation	indoor
Service	continuous
Internal connection	delta
Total losses	~ 6W/kvar
Inner surface finish	zinc passivation
Standards (rack)	IEC 61439-1/2, IEC 61921
Standards (capacitors)	IEC 60831-1/2

	Part number	Power [kvar]	Steps U _e =400V	Weight	Dimensions
		U _e =400V	[kvar]	[kg]	(see chap. 5)
MULTI rack	IX5LFF220050009	20	20	38	130
	IX5LFF240050009	40	40	62	130

REACTIVE POWER REGULATOR

The reactive power regulator is, together with the capacitors and reactors (in detuned filter cabinets), the key component of the automatic power factor correction system.

It is in fact the “intelligent” element, responsible for the verification of the power factor of the load, in function of which controls the switching on and off of the capacitors batteries in order to maintain the power factor of the system beyond the target.

The reactive power regulators RPC used in ICAR branded automatic power factor correction systems are designed to provide the desired power factor while minimizing the wearing on the banks of capacitors, accurate and reliable in measuring and control functions are simple and intuitive in installation and consultation.

By purchasing a branded ICAR automatic power factor correction system you receive it ready for commissioning. In fact the controller is already set, you just need to connect it to the line CT and set the value of the primary current. The controller automatically recognizes the current direction of the CT secondary, to correct any wiring errors.

The flexibility of regulators allows you to modify all the parameters to customize its operation to fit the actual characteristics of the system to be corrected (threshold power factor, sensitivity of step switching, reconnecting time of the steps, presence of photovoltaics, etc.).

As described below, the regulators offer important features as for the maintenance and management of the power factor correction bank, aimed at identifying and solving problems, which could lead to its damage with consequent life expectancy reduction.



RPC 5LGA



RPC 8LGA



RPC 8BGA

System	Regulator
MICROmatic	RPC 5LGA
MINImatic	RPC 5LGA
MIDImatic	RPC 8LGA
MIDImatic <i>(with detuning reactor)</i>	RPC 8BGA + MCP5
MULTImatic	RPC 8BGA + MCP5 (optional)
MULTImatic <i>(with detuning reactor)</i>	RPC 8BGA + MCP5

Reactive power regulators RPC 5LGA and RPC 8LGA

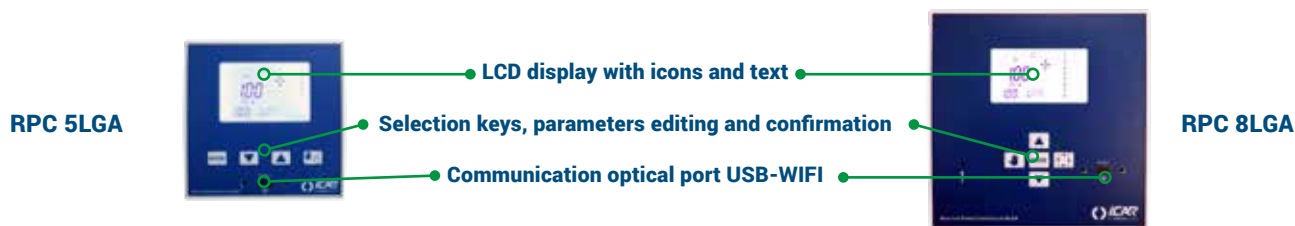

The reactive power regulator RPC 5LGA equips MICROMatic and MINImatic automatic power factor correction systems, while the new regulator RPC 8LGA equips MIDImatic. Both are managed by a microprocessor and offer many features maintaining a simple user interface locally or from a PC.

They are characterized by a large LCD display with text messages (in 6 languages: ITA, ENG, FRA, SPA, POR, GER) and icons for quick and intuitive navigation.

The regulators are very flexible: they are in fact able to adjust the power factor between 0.5 inductive and 0.5 capacitive, to operating with power from 100 to 440 VAC, to run on the 4 quadrants for cogeneration installations, to accept in Input CT secondary 5A or 1A.

The regulators have standard temperature control and the ability to configure one of the available relays for activating visual alarms sound at a distance; also control the distortion of current and voltage.

Regulators RPC 5LGA-8LGA can operate in automatic or manual mode: in the first case in complete autonomy by switching batteries available up to the desired power factor; in the second case it will be the operator to force the insertion and disconnection of the battery: the regulator still oversee operations to prevent potential damage to the capacitors (for example by assessing compliance of discharge times before a subsequent insertion).

Measurement functions

Regulators RPC 5LGA and 8LGA provide many standard measurements in order to check and monitor the correct electrical and temperature conditions of the power factor correction system.

Display shows the following values: power factor, voltage, current, delta kvar (reactive power missing to reach the target power factor), average weekly power factor, total harmonic distortion of the current system (THDI_r%) with detailed harmonic for harmonic from 2nd to 15th, total harmonic distortion of the voltage (THDV_r%) with detail for harmonic from 2nd to 15th, total harmonic distortion in the current % (THDI_c%) capacitor, temperature.

The controller stores and makes available for consultation the maximum value of each of these variables, to evaluate the most severe stress suffered by the automatic power factor correction since the last reset: the temperature, the voltage and the total harmonic distortion have a strong impact on the capacitors as if they hold more than the nominal values can drastically reduce the service life.

Alarms

The ICAR RPC regulators offer many different alarms as standard, which help in the correct operation of the system. The alarms are set to the following values:

- Under-compensation: the alarm is activated if, with all the steps of power factor correction switched on, the power factor is lower than the desired value.
- Over-compensation: the alarm is activated if, with all the steps of power factor correction switched off, the power

factor is greater than the desired value.

- Minimum and maximum current: to assess the condition of the system load.
- Minimum and maximum voltage: to evaluate the stresses due to the variations of the supply voltage.
- Maximum THD%: to assess the pollution of network as regards to harmonic current.
- Maximum temperature in the enclosure: to monitor the capacitor climatic conditions.
- Short voltage interruptions.

Alarms are programmable (enable, threshold, time of activation / deactivation).

Display Indications

The LCD display icons and text provides the following information for quick identification of the state of the system:

- Operating mode automatic/manual.
- Status of each battery (on / off).
- Recognition power factor inductive / capacitive.
- Type of value displayed.
- Active alarm code, and explanatory text (in a language of choice among the 6 available: ITA, ENG, FRA, SPA, POR, GER).

Safety

The RPC 5LGA and 8LGA controllers have passwords to prevent not authorized access.

A backup copy of the factory settings is always available in memory.

Contacts

The regulators RPC 5LGA and 8LGA have power contacts for controlling the steps, to control the eventual cooling fan and for the activation of alarms to distance; contacts are NO and have a range of 5A at 250Vac or 1.5A at 440Vac.

A contact is in exchange for alarm functions (NO or NC).

Additional module

The regulator RPC 5LGA has the ability to accommodate, in the back slot, an additional module.

The regulator RPC 8LGA has two rear slots to accommodate up to two additional modules.

Once installed an additional module, the controller recognizes and activates the menu for its programming.

Additional modules can be installed even in the bank already in service. Slots for additional module may be already used to implement necessary functions to the context in which the controller is mounted. If you decide to add a module to an already operating, ensure that there is an available slot.

- **OUT2NO** two digital outputs module for additional step control (two 5A 250Vac relays)
- **COM232** isolated RS232 interface
- **COM485** isolated RS485 interface
- **WEBETH** Ethernet interface (only for RPC 8LGA)



Data sheet	RPC 5LGA	RPC 8LGA
Control	microprocessor	
Auxiliary supply voltage	100÷440Vac	
Frequency	50Hz/60Hz	
Voltage measuring input	100÷600V	
Current measuring input	5A (1A programmable)	
Current reading range	from 25mA to 6A (from 25mA to 1.2A)	
Automatic current way sensing	yes	
Operation in systems with cogeneration	yes	
Power consumption	9.5VA	
Output relay	5A - 250Vac	
Cosp adjustment	from 0.5 ind. to 0.5 cap.	
Step switching time	1s ÷ 1000s	
Alarm relay	yes	
Degree of protection	IP54 on front, IP20 at terminals	
Operating temperature	from -20°C to +60°C	
Storage temperature	from -30°C to + 80°C	
Front optical port	for communication USB or WIFI with dedicated accessories	
Compliance with the standards	IEC 61010-1; IEC 61000-6-2; IEC 61000-6-4; UL508; CSA C22-2 nr.14	
Output relay number	5 (expandable up to 7)	8 (expandable up to 12)
Dimensions	96x96mm	144x144mm
Weight	0.35kg	0.65kg
Part number	6CF46411050	6CF025

Reactive power regulators RPC 8BGA



The RPC 8BGA reactive power regulator equips MULTImatic automatic power factor correction systems. It is a very innovative controller, with exclusive features:

- High electrical performance
- Extended Capabilities
- Graphic display
- Advanced communication
- Upgradability, even after installation
- Powerful supervision software
- Choice language (10 languages available on board).

More details below, referring to the following page tables and manuals for further information.

High electrical performance

The 8BGA controller is equipped with powerful hardware, which allows a considerable electrical performances: it can be connected to the CT secondary 5A or 1A, it can work on networks with voltages from 100 to 600Vac with a measuring range from 75Vac to 760Vac, it can be connected to a single CT (typical configuration of the power factor correction) or three-CTs (for a more accurate measurement of the power factor, and this fact makes the 8BGA controller to refocus and to be a multimeter as well).

Extended Capabilities

The 8BGA reactive power regulator is controlled by a powerful microprocessor that allows a set of new functions to solve problems even in complex plant. 8BGA can work master-slave functions, handles up to 10 languages simultaneously, can be used in MV systems managing the transformation ratio of the VT, it can support multiple inputs and outputs via optional modules, it can handle target cos phi from 0.5 inductive to 0.5 capacitive. 8BGA can build a network of 4 wired units (one master three slaves) to be able to handle up to 32 steps of power factor correction in a consistent and uniform way.

Graphical display with high readability

Forget the regulators with small displays and difficult to read: 8BGA will amaze you with its display matrix graphic LCD 128x80 pixels. The detail and sharpness allow intuitive navigation between the different menus, represented with text and icons.

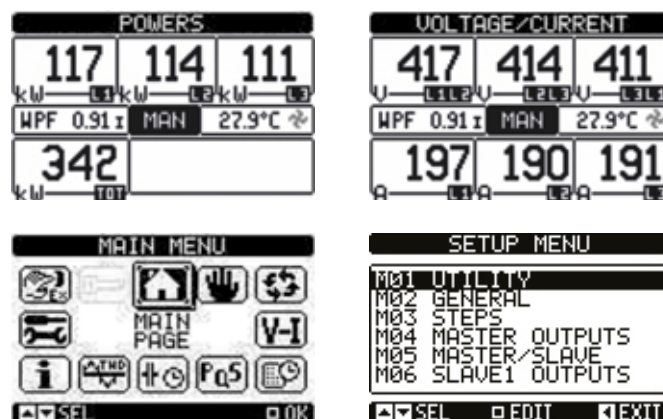
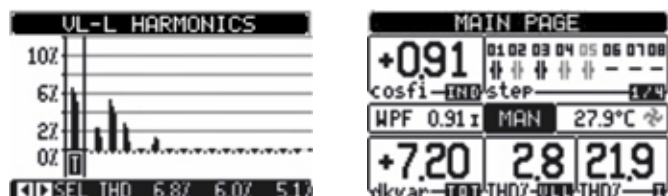

Advanced communication

8BGA born to be a regulator able to communicate in a manner in line with the latest technology: Ethernet, RS485, USB, WIFI.

Now you can see the information of the company cos phi, without having to go in front of the regulator. Now you can consult it by a PC.

The information about the cos phi is important, because it impacts heavily on the company's income statement.

Evolutivity

The "basic" 8BGA regulator can be enhanced with up to four additional modules "plug and play" which greatly expands its performance.

It is possible to add additional control relays (up to a total of 16), even for a static control (thyristors), digital and analog inputs, analog outputs, communication modules.

Your controller can become a small PLC, and the PFC system can become a point of data aggregation, for remote communication.

Measurement functions and help to maintain

8BGA is a real evolved multimeter, thanks also to the graphic display of excellent readability and to the powerful microprocessor.

The measured parameters are the basic ones (cos ϕ , PF, V, I, P, Q, A, Ea, Er) with the addition of the distortion of the voltage and current (THD, histogram of the value of each harmonic, waveform graphic visualization).

If 8BGA is connected to three CT, the harmonic analysis is detailed for each phase, in order to identify any anomalies of single phase loads. 8BGA measure and count values that can help in ruling the PFC (temperature, number of switching of each step). 8BGA also suggests the maintenance to be carried out by means of simple messages on the display. Keep efficient capacitor becomes much easier. 8BGA stores the maximum values of current, voltage, temperature, each associated with the date and time of the event for a better analysis of what happened.

Alarms

The set of alarms (maximum and minimum voltage, maximum and minimum current, over and undercompensation, overload of the capacitors, maximum temperature, microinterruption) associated with the readability of the messages on the display allows a better understanding of what happened.

Even alarm programming (enable / disable, delay, relapse etc.) is easier and faster.

Data sheet	RPC 8BGA
Controllo	a microprocessore
Auxiliary supply voltage	100÷440Vac
Frequency	50Hz/60Hz
Voltage measuring input	100÷600V (-15% / +10%)
Current measuring input	5A (1A programmable)
Current reading range	from 25mA to 6A (from 10mA to 1.2A)
Automatic current way sensing	yes
Operation in systems with cogeneration	yes
Power consumption	12VA (10.5W)
Output relay	5A - 250Vac
Cosφ adjustment	from 0.5 ind. to 0.5 cap. (tan φ da -1.732 a +1.732)
Step switching time	1s ÷ 1000s (20ms with STR4NO module)
Alarm relay	yes
Degree of protection	IP55 on front, IP20 at terminals
Operating temperature	from -30°C to +70°C
Storage temperature	from -30°C to + 80°C
Front optical port	for communication USB or WIFI with dedicated accessories
Temperature control	from -30°C to +85°C
Compliance with the standards	IEC 61010-1; IEC 61000-6-2; IEC 61000-6-3; UL508; CSA C22-2 nr.14
Output relay number	8 (expandable up to 16)
Dimensions	144x144mm
Weight	0.98kg
Part number	6CF46411000

Additional modules

The RPC 8BGA controller accommodates up to 4 additional modules "plug & play". Once you have added an additional module, the controller recognizes and activates the menu for its programming. Additional modules can also be installed retrospectively (consult us).

Digital inputs and outputs

These modules allow you to increase the contacts funding for control of the steps contactors (OUT2NO module) or thyristors (STR4NO module) switched banks, or to add inputs and / or digital / analog acquisition of parameters and implementing simple logic.

- **OUT2NO** module 2 digital outputs to control additional steps (two relays 5A 250 Vac)
- **STR4NO** module 4 static outputs for thyristor control steps (range SPEED)
- **INP40C** module 4 digital inputs

Protection functions

The control and protection module MCP5 allows a more detailed inspection of the electrical parameter and temperature that can damage the capacitors.

Thanks to algorithms particularly suitable for automatic equipment consisting of capacitors and reactors.

- **MCP5** module for protection and control for additional safety of capacitors, especially suitable in the detuned banks

MULTImatic detuned systems are equipped with RPC 8BGA controller with MCP5 module.

This module has very important function: it directly monitors, through two CTs installed inside, the current in the capacitors analyzing the harmonic content.

In case of harmonic content increases (for example, due to the aging of the capacitors) exceeding a certain limit value, the PFC system is taken out of service, excluding the risk of bursting or overcharging of the capacitors.

The MCP5 module allows the harmonic currents affecting the capacitors to be monitored directly on the RPC 8BGA controller screens, as can be seen in the two pictures shown below.

The individual harmonics are kept under control, with the possibility of setting an alarm level and an intervention level on each. The MCP5 module also allows to monitor two additional temperatures in order to avoid excessive overheating even inside the panel.

Without this functionality, the regulator would carry out the evaluation of the harmonic content with greater difficulty and less precision.

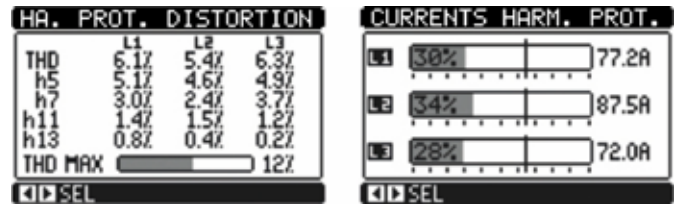

Analysis of the harmonic current absorbed by the capacitors, in percentage, detailed harmonic by harmonic, and absolute.

Communication functions

RPC 8BGA regulator is very powerful in terms of communication. The modules dedicated to these functions allow multiple solutions to remotely control the power factor system and all other variables measured, calculated or obtained from the instrument.

- **COM232** isolated RS232 interface
- **COM485** isolated RS485 interface
- **WEBETH** Ethernet interface
- **COMPRO** isolated Profibus-DP interface
- **CX01** cable connection from the RPC 8BGA optical port to the USB port of the computer for programming, downloading / uploading data, diagnostics etc
- **CX02** device to connect the optical port in the RPC 8BGA via WIFI: for programming, downloading / uploading data, diagnostics etc

DIMENSIONS

The following pages show the dimensions of the equipment in this catalog, identified with the respective numerical code. This page shows the total dimensions, for a first evaluation of the space occupied. The dimensions in the table include (where present) handles, exchangers, turrets, etc. For more details, consult the individual drawings.

	dimensional number	Dimensions [mm]		
		W	D	H
SUPERriphaso	21	195	89	245
MICROfix	43	310	200	450
	44	430	250	600
	45	550	500	900
MICROmatic	49	460	260	480
	50	610	260	480
MINImatic	55	420	425	745
	56	420	425	965
	57	420	425	1183
	58	420	425	1403
	60¹	600	440	1500
	61¹	600	440	1700
MIDImatic	64	600	690	1835
MULTImatic	70	610	670	2160
	71	610	670	2360
	72	610	670	1760
	73	610	670	2160
	74	610	670	1960
	75	610	777	1760
	76¹	822	670	2160
	77¹	822	670	2360
	78²	610	777	2360
	80	822	670	1760
	81²	610	777	1960
	82¹	822	670	1960
	83²	1220	777	1760
	84³	1432	777	1760
	85²	1220	777	1960
	86³	1432	777	1960
	90	1220	670	2160
	91	1220	670	2360
	92	1220	670	1760
	93	1220	777	2160
	94	1220	670	1960
95³	1432	777	2360	
96³	1432	777	2160	
98²	1220	777	2360	
101	1830	670	2160	
102	1830	670	2360	
103³	2042	777	2160	
104³	2042	777	2360	

1. Leave 250mm of free air on each side (consult us).

2. Leave 250mm of free air behind (consult us).

3. Leave 250mm of free air both on the back and on each side (consult us).

21

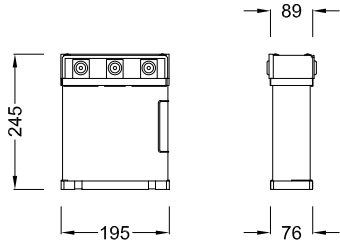

Max N° of modules in parallel: 6



43

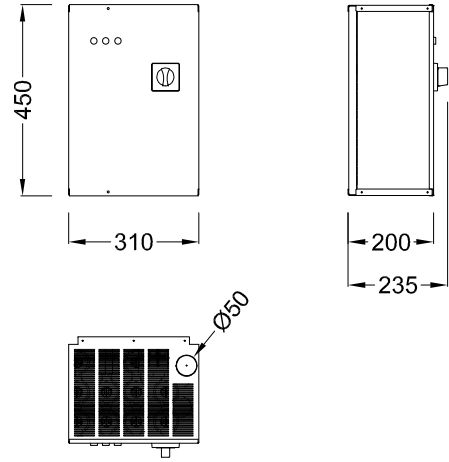

44

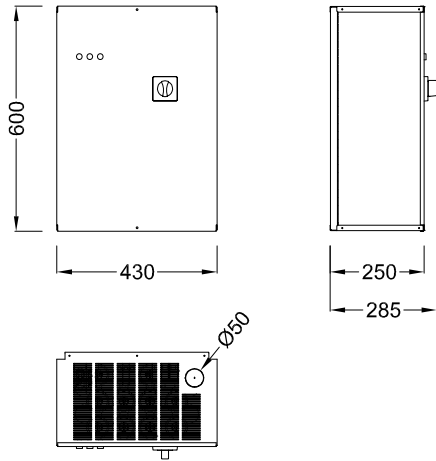

45

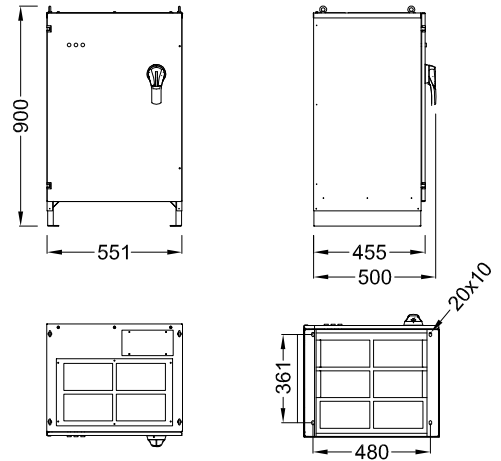

49

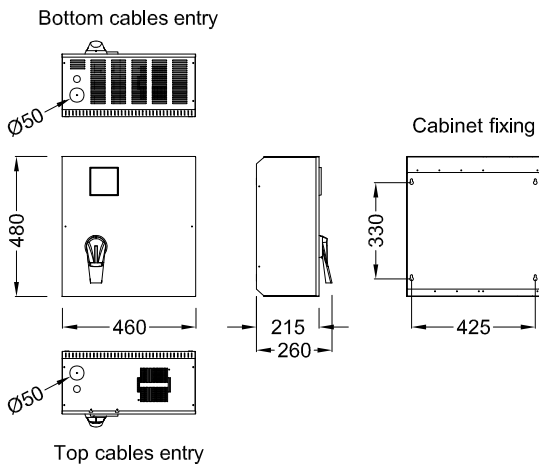

50

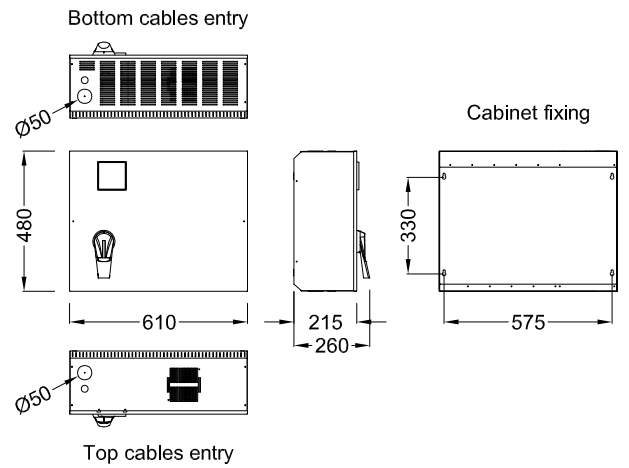

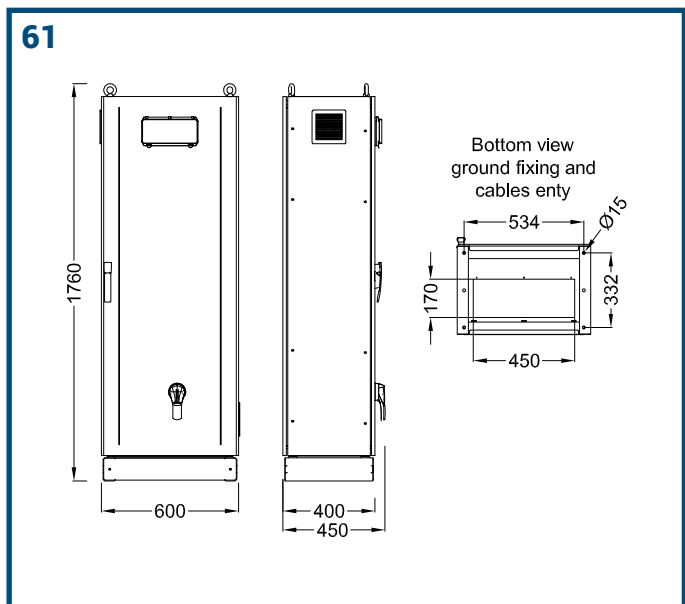
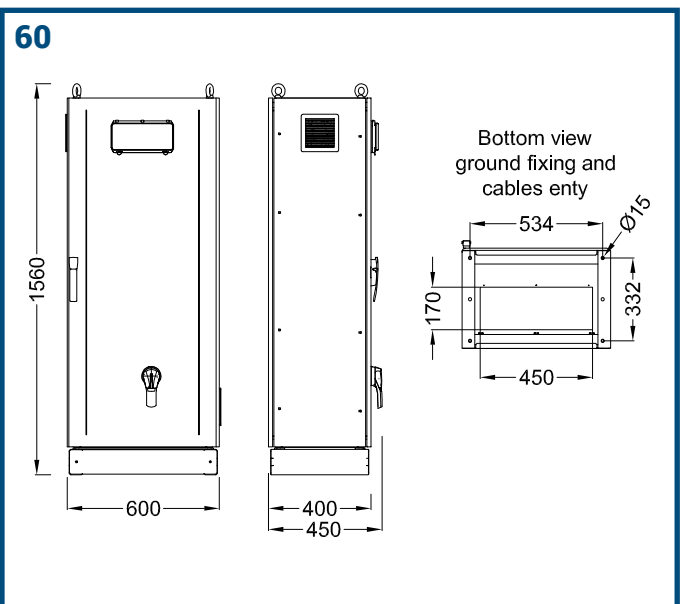
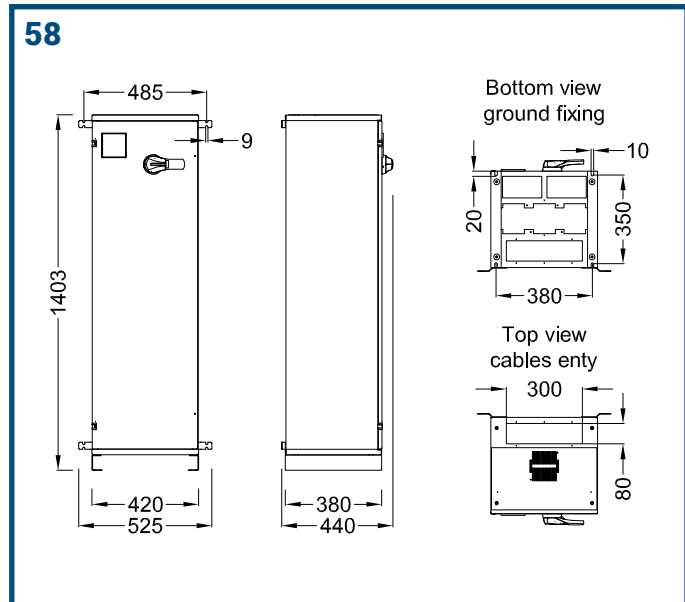
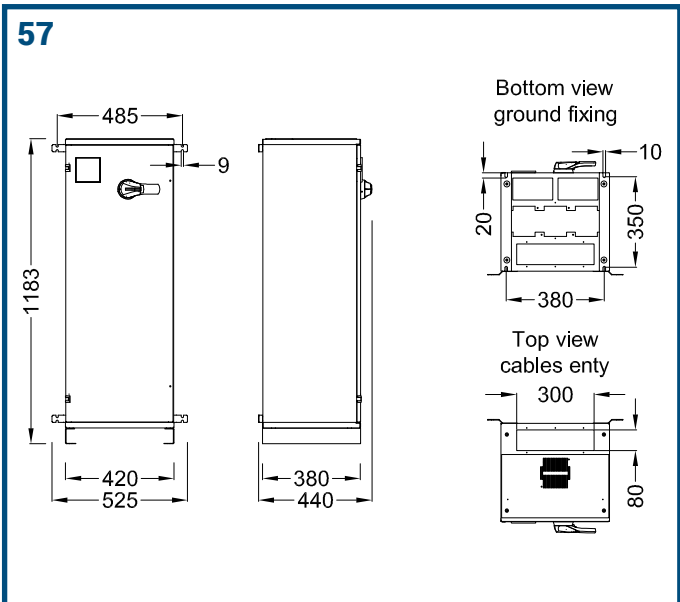
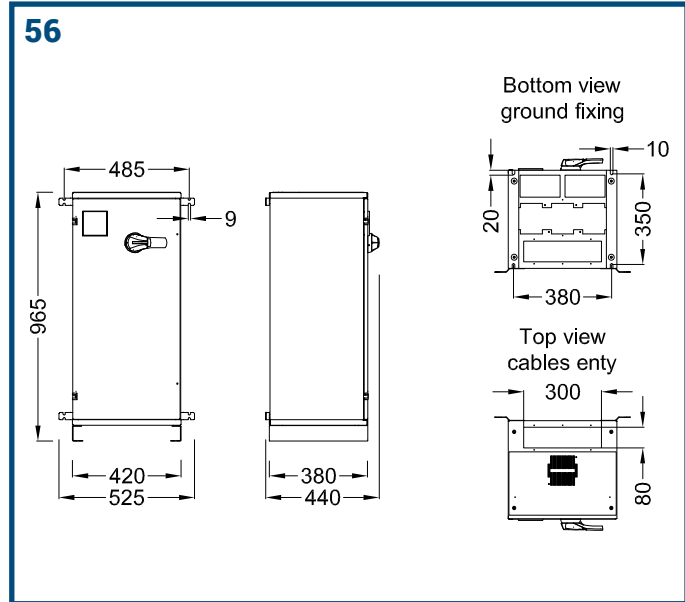
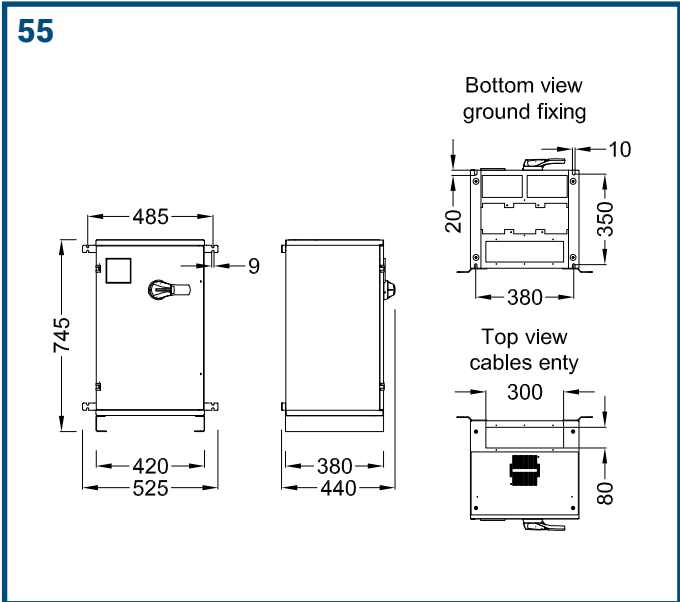

64

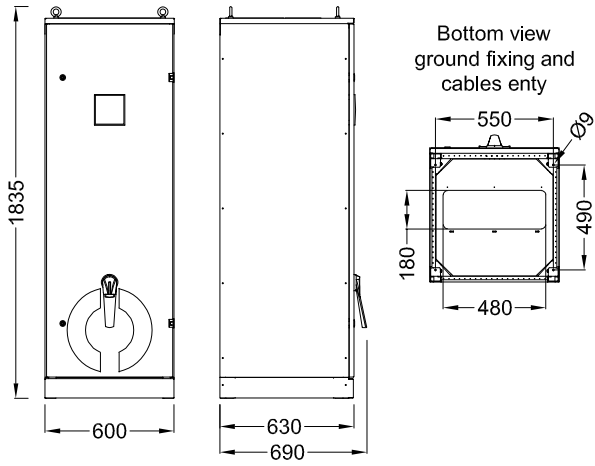

70

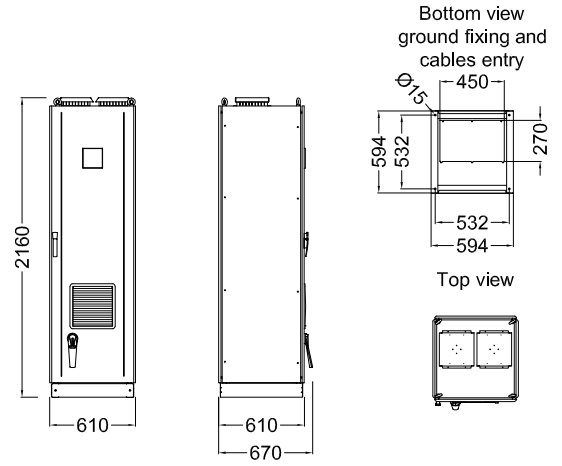

71

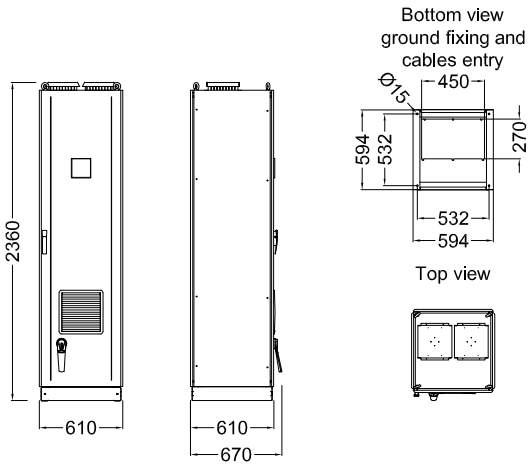

72

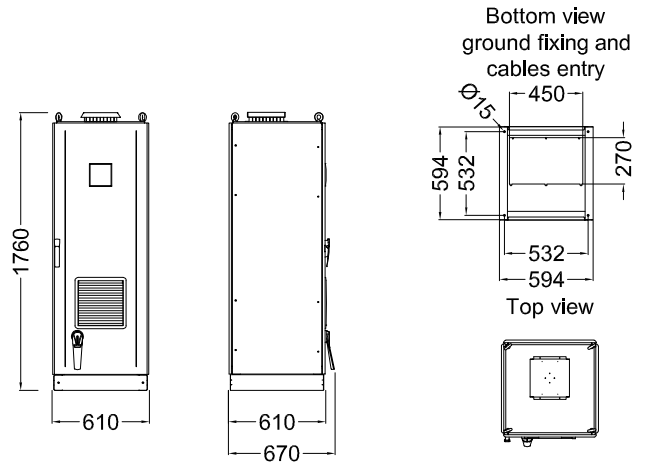

73

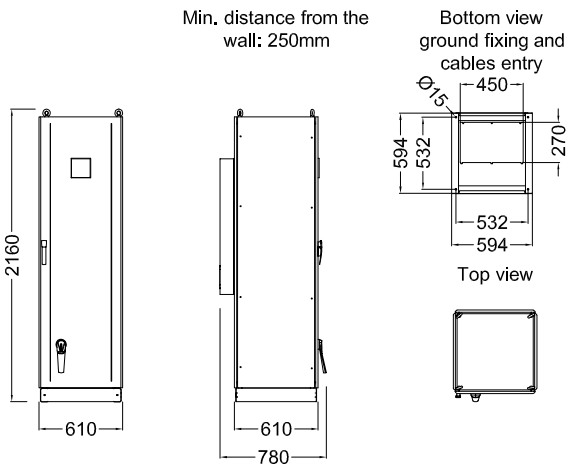

74

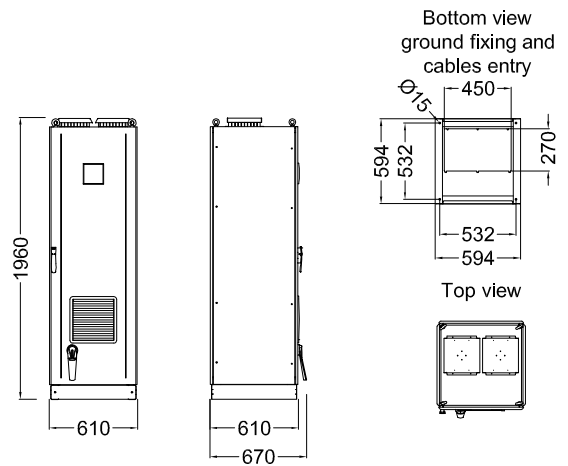

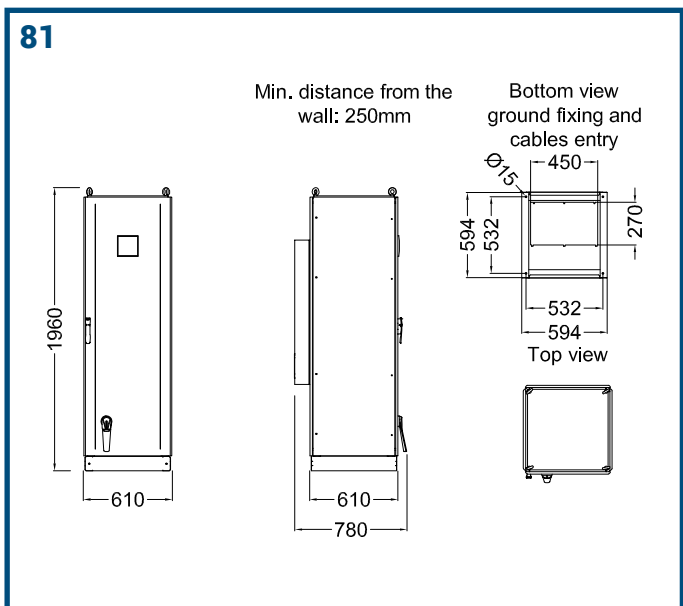
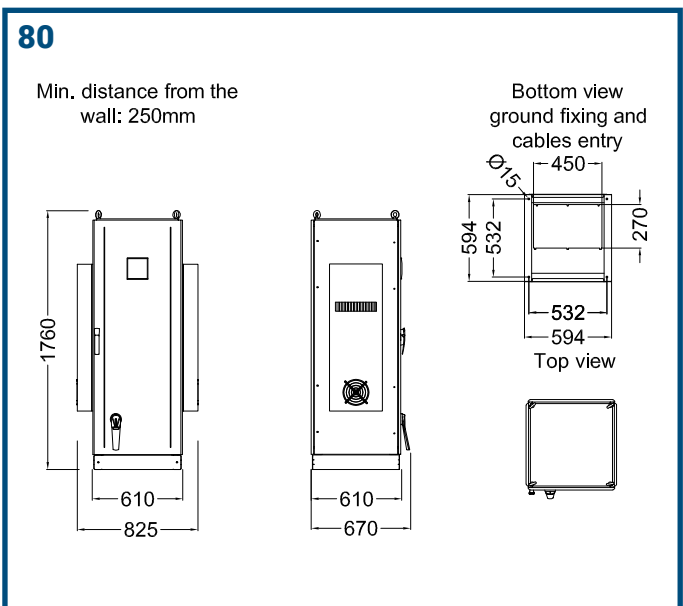
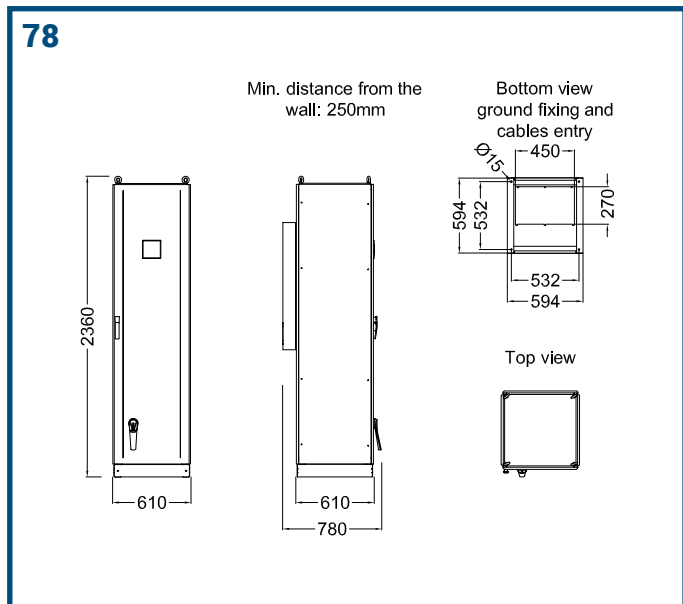
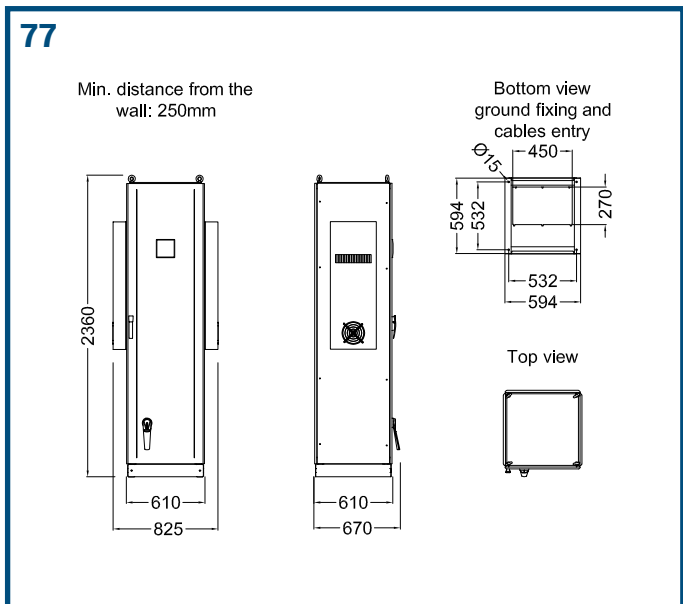
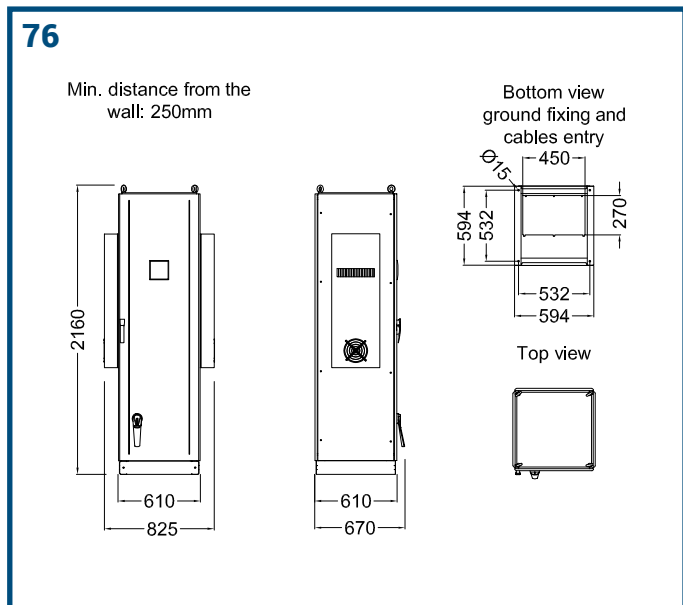
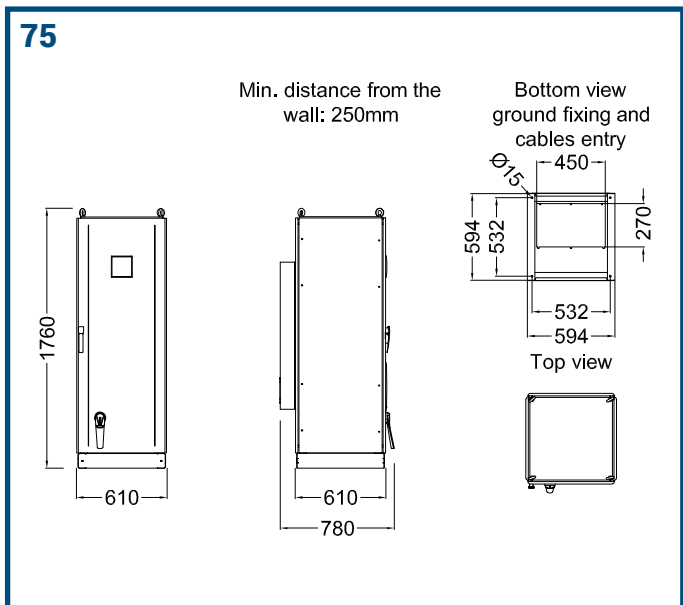

82

Min. distance from the wall: 250mm

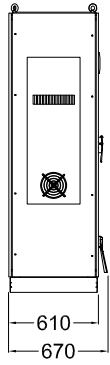
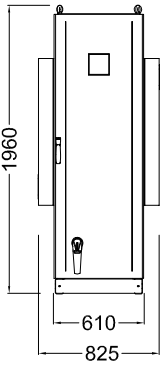

Bottom view ground fixing and cables entry

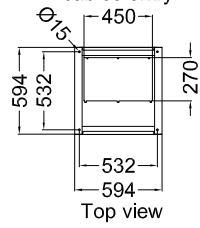

Top view

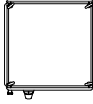

83

Min. distance from the wall: 250mm

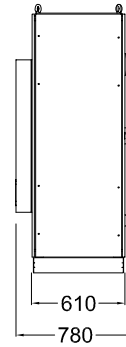
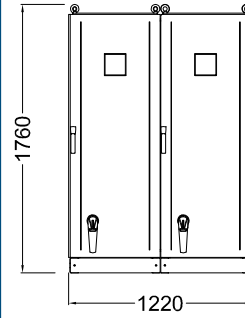

Bottom view ground fixing and cables entry

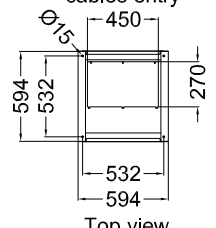

Top view

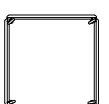

84

Min. distance from the wall: 250mm

Min. distance from the wall: 250mm

Bottom view ground fixing and cables entry

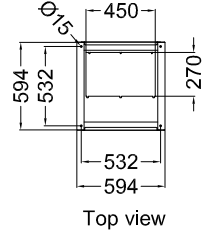
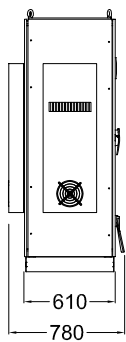

Top view

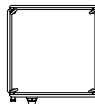

85

Min. distance from the wall: 250mm

Bottom view ground fixing and cables entry

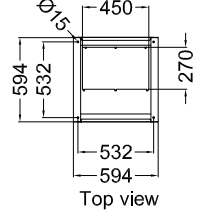
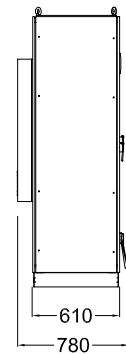
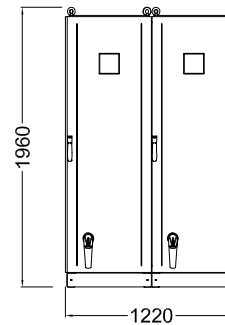

Top view

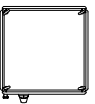

86

Min. distance from the wall: 250mm

Min. distance from the wall: 250mm

Bottom view ground fixing and cables entry

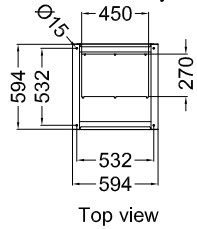
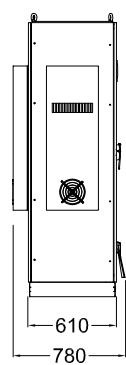
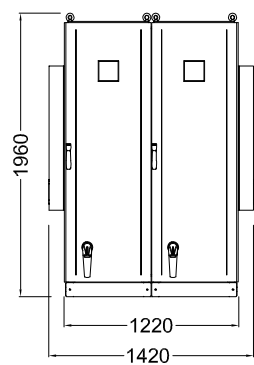

Top view

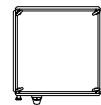

90

Bottom view ground fixing and cables entry

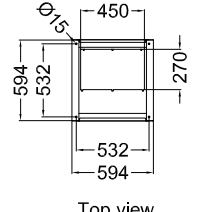
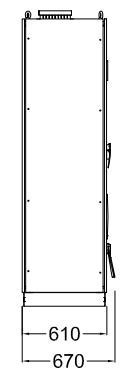
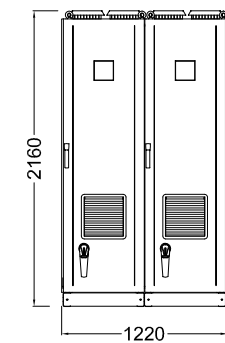

Top view

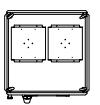

Note: MULTImatic in two columns have two disconnectors and require two cable entries. For versions with single cable entry, contact us.

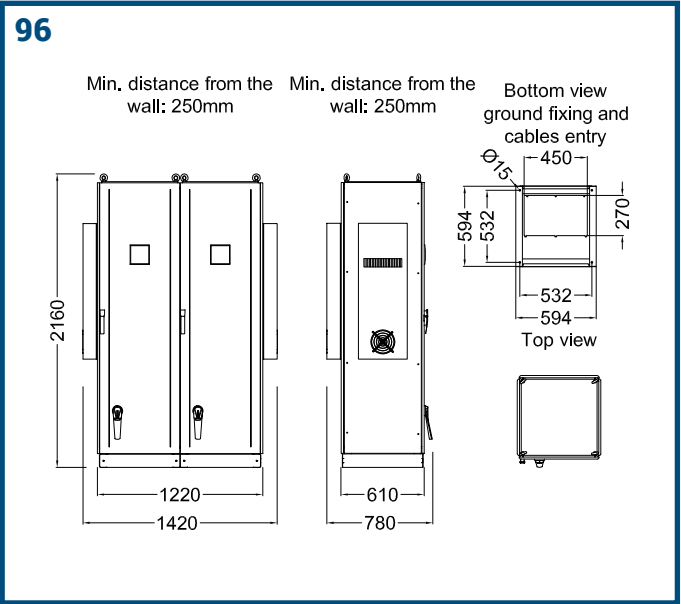
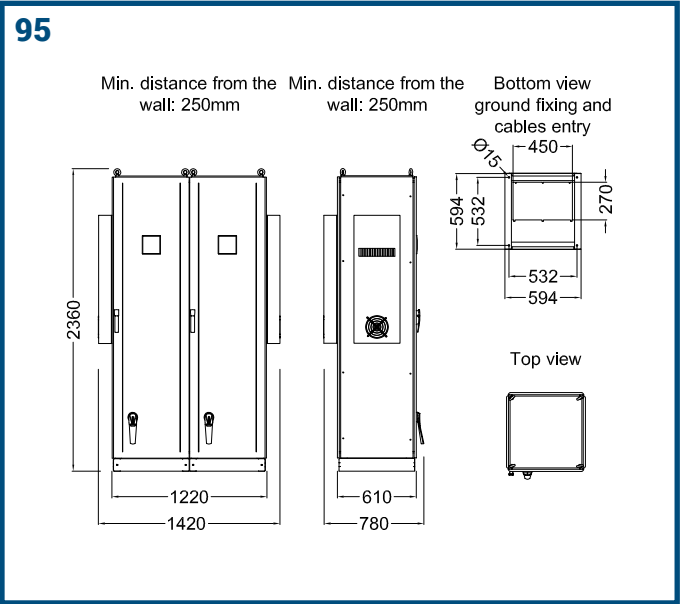
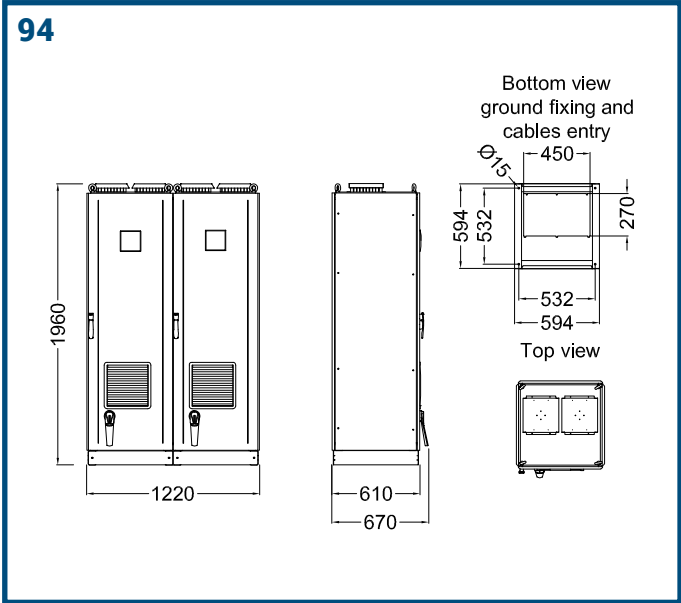
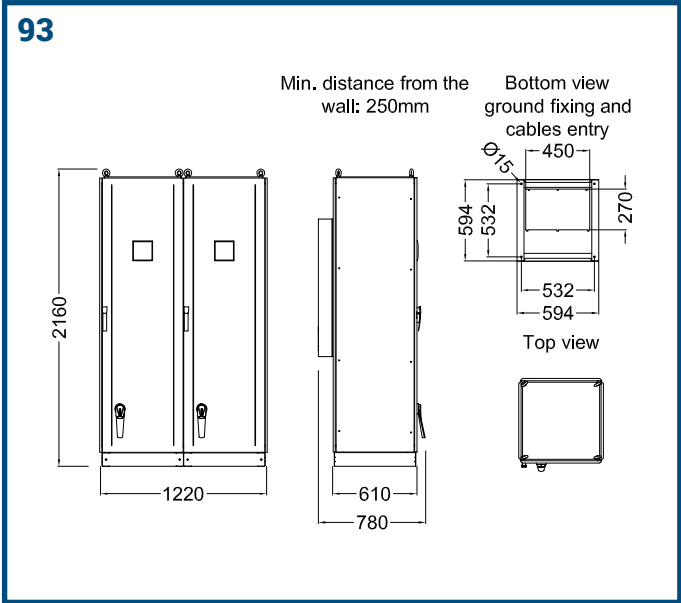
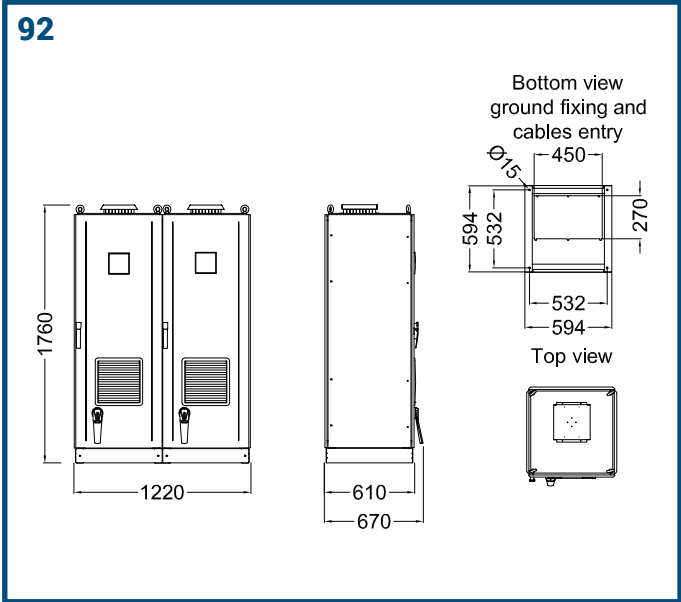
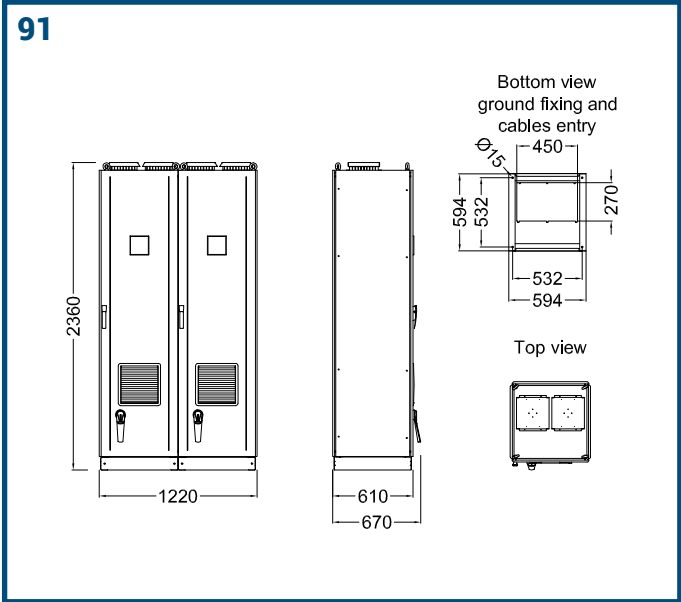

Note: MULTImatic in two columns have two disconnectors and require two cable entries. For versions with single cable entry, contact us.

98

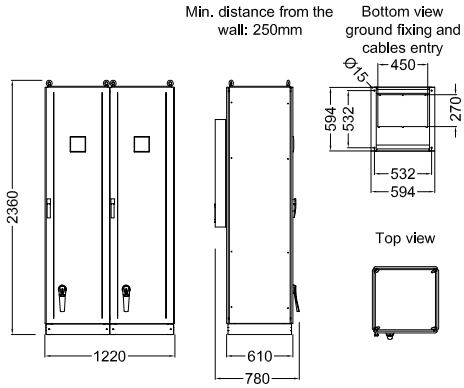

101

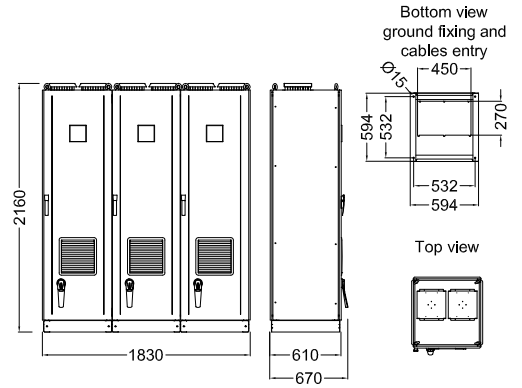

102

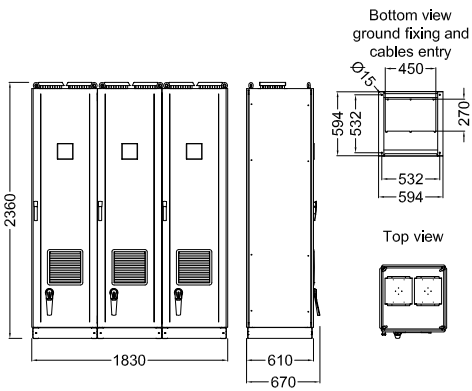

103

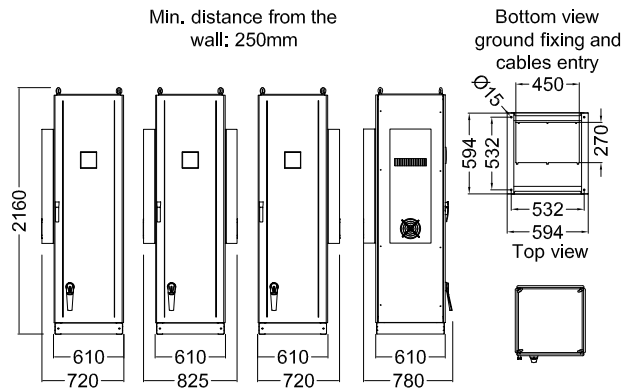

104

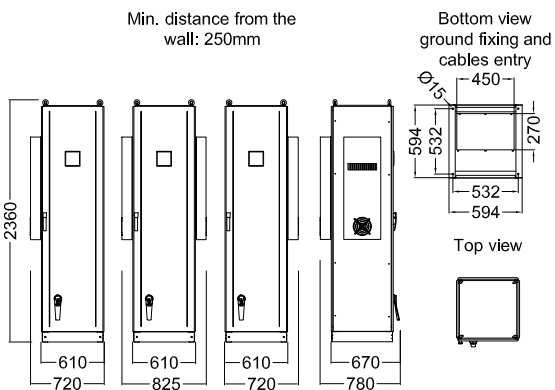

109

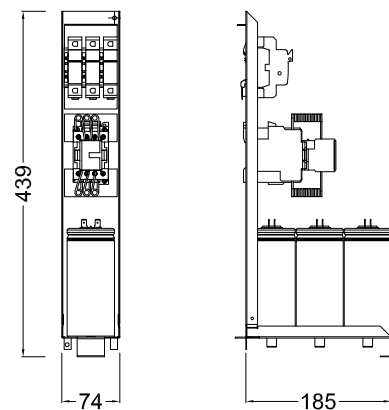

Note: MULTImatic in three columns have three disconnectors and require three cable entries. For versions with single cable entry, contact us.

110

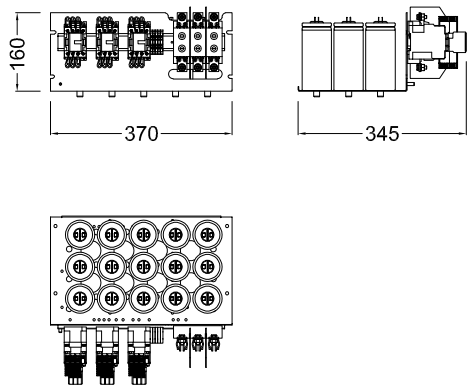

120

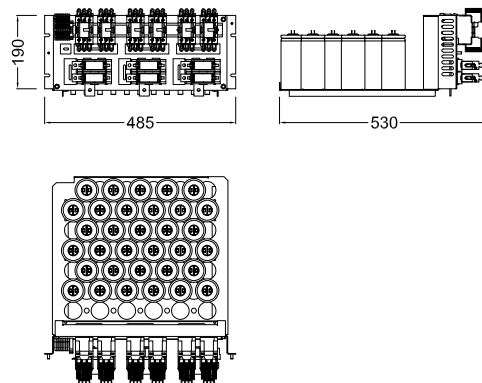

130

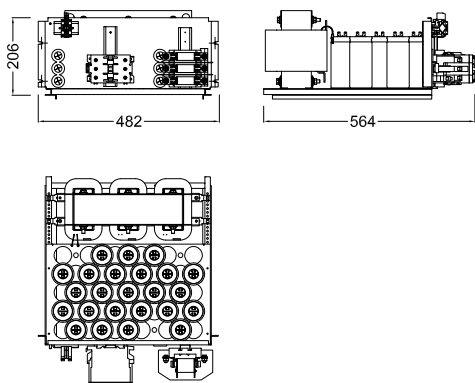

135

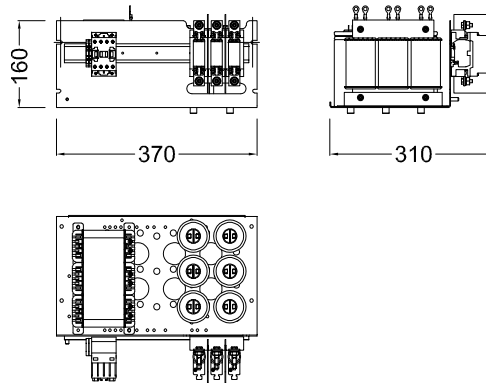

144

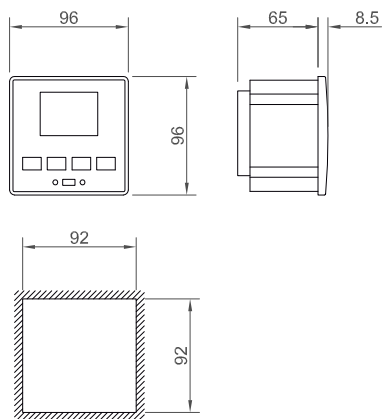

147

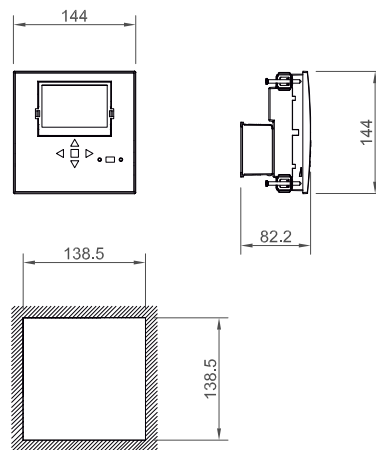



TECHNICAL NOTES

Power factor correction: why?

In electrical circuits the current is in phase with the voltage whenever are in presence of resistors, whereas the current is lagging if the load is inductive (motors, transformers with no load conditions), and leading if the load is capacitive (capacitors).

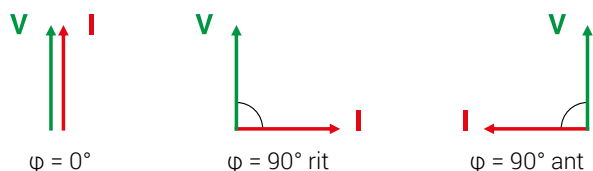

The total absorbed current, for example, by a motor is determined by vector addition of:

- I_R resistive current;
- I_L inductive reactive current;

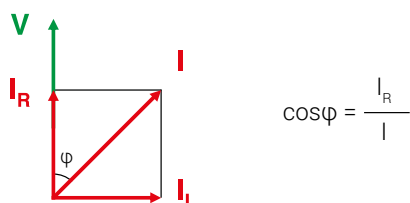

These currents are related to the following powers:

- **Active power** linked to I_R ;
- **Reactive power** linked to I_L ;

The reactive power doesn't produce mechanical work and it is an additional load for the energy supplier.

The parameter that defines the consumption of reactive power is the power factor.

We define power factor the ratio between active power and apparent power:

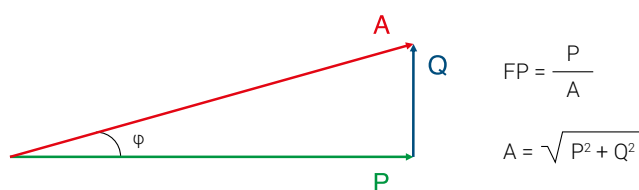

As far as there are not harmonic currents power factor coincides to $\cos\phi$ of the angle between current and voltage vectors.

$\cos\phi$ decreases as the reactive absorbed power increases.

Low $\cos\phi$, has the following disadvantages:

- High power losses in the electrical lines.
- High voltage drop in the electrical lines.
- Over sizing of generators, electric lines and transformers.

From this we understand the importance to improve (increase) the power factor.

Capacitors need to obtain this result.

Power factor correction: how?

By installing a capacitor bank it is possible to reduce the reactive power absorbed by the inductive loads in the system and consequently to improve power factor. It is suitable to have $\cos\phi$ a little in excess of 0.95 to avoid paying the penalties provided for by the law.

The choice of the correct power factor correction equipment depends on the type of loads present and by their way of working.

The choice is between **individual compensation** and **central compensation**.

Nel caso di rifasamento distribuito, le unità rifasanti sono disposte nelle immediate vicinanze di ogni singolo carico che si vuole rifasare.

Individual compensation: power factor correction is wired at each single load (i.e. motor terminals).

Central compensation: there is only one bank of capacitors on the main power distribution switch board or substation.

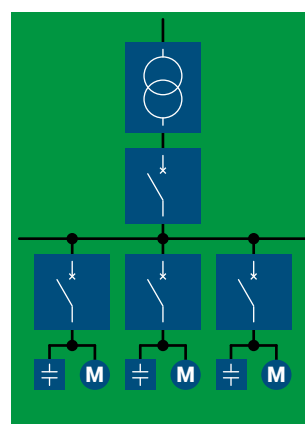

Individual compensation

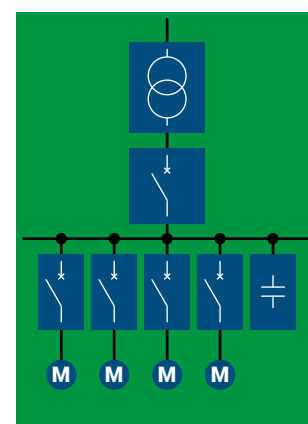

Central compensation

The individual compensation is a simple technical solution: the capacitor and the user equipment follow the same sorts during the daily work, so the regulation of the $\cos\phi$ becomes systematic and closely linked to the load. Another great advantage of this type of power factor correction is the simple installation with low costs.

The daily trend of the loads has a fundamental importance for the choice of most suitable power factor correction. In many systems, not all the loads work in the same time and some of them work only a few hours per day. It is clear that the solution of the individual compensation becomes too expensive for the high number of capacitors that have to be installed. Most of these capacitors will not be used for long period of time.

The individual compensation is more effective if the majority of the reactive power is concentrated on a few substations loads that work long period of time.

Central compensation is best suited for systems where the load fluctuates throughout the day. If the absorption of reactive power is very variable, it is advisable the use of automatic regulation in preference to fixed capacitors.

Power factor correction: How many?

The choice of capacitor bank to install in a system is closely depended from:

- $\cos\varphi_2$ value that we would obtain;
- $\cos\varphi_1$ starting value;
- installed active power.

By the following equation:

$$Q_C = P \cdot (\tan\varphi_1 - \tan\varphi_2)$$

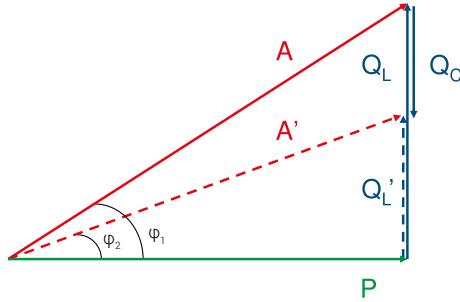

Can be also written $Q_C = k \cdot P$

where the parameter k is easily calculated using Table 1 (in APPENDIX).

As example if we have installed a load that absorbs an active power of 300 kW having a power factor 0.7 and we want to increase it until 0.97.

From the table 1 we find: $k = 0,770$.

and therefore:

$$Q_C = 0,770 \cdot 300 = 231 \text{ kvar}$$

where:

Q_C = required capacitors reactive output (kvar);

P = active power (kW);

Q_L, Q_L' = inductive reactive output before and after the installation of the capacitor bank;

A, A' = apparent power before and after the power factor correction (kVA).

A typical example of power factor correction, sometimes not much considered but surely important, concerns the power factor correction of transformers for the distribution of energy.

It is essentially a fixed power factor correction that must compensate for the reactive power absorbed by the transformer in its no load condition (this happens often during the night). The calculation of the needed reactive output is very easy and it bases itself on this equation:

$$Q_C = I_0\% \cdot \frac{A_N}{100}$$

where

$I_0\%$ = magnetising current of the transformer

A_N = apparent rated power in kVA of the transformer

If we don't have these parameters, it is convenient to use the following table.

Power transformer [kVA]	Standard		Low losses	
	Oil [kvar]	Resin [kvar]	Oil [kvar]	Resin [kvar]
10	1	1,5	–	–
20	2	1,7	–	–
50	4	2	–	–
75	5	2,5	–	–
100	5	2,5	1	2
160	7	4	1,5	2,5
200	7,5	5	2	2,5
250	8	7,5	2	3
315	10	7,5	2,5	3,5
400	12,5	8	2,5	4
500	15	10	3	5
630	17,5	12,5	3	6
800	20	15	3,5	6,5
1000	25	17,5	3,5	7
1250	30	20	4	7,5
1600	35	22	4	8
2000	40	25	4,5	8,5
2500	50	35	5	9
3150	60	50	6	10

Another very important example of power factor correction concerns asynchronous three-phase motors that are individually corrected.

The reactive power likely needed is reported on following table:

Motor power		Required reactive power [kvar]				
HP	KW	3000 rpm	1500 rpm	1000 rpm	750 rpm	500 rpm
0,4	0,55	–	–	0,5	0,5	–
1	0,73	0,5	0,5	0,6	0,6	–
2	1,47	0,8	0,8	1	1	–
3	2,21	1	1	1,2	1,6	–
5	3,68	1,6	1,6	2	2,5	–
7	5,15	2	2	2,5	3	–
10	7,36	3	3	4	4	5
15	11	4	5	5	6	6
30	22,1	10	10	10	12	15
50	36,8	15	20	20	25	25
100	73,6	25	30	30	30	40
150	110	30	40	40	50	60
200	147	40	50	50	60	70
250	184	50	60	60	70	80

Be careful: the capacitor output must not be dimensioned too high for individual compensated machines where the capacitor is directly connected with the motor terminals. The capacitor placed in parallel may act as a generator for the motor which will cause serious overvoltages (self-excitation phenomena). In case of wound rotor motor the reactive power of the capacitor bank must be increased by 5%.

Power factor correction: technical reasons

Recent energy market deregulation, along with new potential energy supplier rising, had lead to many and different type of invoicing which are not very clear in showing Power Factor up. However as energy final price is steady growing, to correct power factor is becoming more and more convenient. In most of the cases power factor improvement device prime cost is paid back in few months.

Technical-economical advantages of the installation of a capacitor bank are the following:

- Decrease of the losses in the network and on the transformers caused by the lower absorbed current.
- Decrease of voltage drops on lines.
- Optimisation of the system sizing.

The current I, that flows in the system, is calculated by:

$$I = \frac{P}{\sqrt{3} \cdot V \cdot \cos\phi}$$

where

P = Active power.

V = Nominal voltage.

While $\cos\phi$ increases, with the same absorbed power we can obtain a reduction in the value of the current and as a consequence the losses in the network and on the transformers are reduced.

Therefore we have an important saving on the size of electrical equipment used on a system. The best system sizing has some consequence on the line voltage drop. We can easily see that looking at the following formula:

$$\Delta V = R \cdot \frac{P}{V} + X \cdot \frac{Q}{V}$$

where

P = Active power on the network (kW).

Q = Reactive power on the network (kvar)

while R is the cable resistance and X its reactance ($R \ll X$).

The capacitor bank installation reduces Q so we have a lower voltage drop. If, for a wrong calculation of the installed capacitor bank value, the reactive part of the above equation becomes negative, instead of a reduction of the voltage drop we have an increasing of the voltage at the end of the line (Ferranti Effect) with dangerous consequence for the installed loads.

Some examples clarify the concepts set out above:

$\cos\phi$	Power loss ¹ [kW]	Supplied active power ² [kW]
0,5	3,2	50
0,6	2,3	60
0,7	1,6	70
0,8	1,3	80
0,9	1	90
1	0	100

1. In function of $\cos\phi$, from a copper cable 3 x 25mm² 100m long carrying 40kW at 400Vac
 2. By a 100kVA transformer, in function of $\cos\phi$

As we can see as the power factor increases we have fewer losses in the network and more active power from the same KVA. This allows us to optimise on the system sizing.

Power factor correction: Harmonics in the network

The distortions of the voltage and current waveforms are generated by non-linear loads (inverter, saturated transformers, rectifier, etc.) and produce the following problems:

- On the AC motors we find mechanical vibration that can reduce expected life. The increase of the losses creates overheating with consequent damaging of the insulating materials.
- In transformers they increase the copper and iron losses with possible damaging of the windings. The presence of direct voltage or current could cause the saturation of the cores with consequent increasing of the magnetising current.
- The capacitors suffer from the overheating and the increasing of the voltage that reduce their life.

The waveform of the current (or voltage) generated by a nonlinear load being periodical, could be represented by the sum of many sinusoidal waves (a 50Hz component called fundamental and other components with multiple frequency of the fundamental component so called **harmonics**).

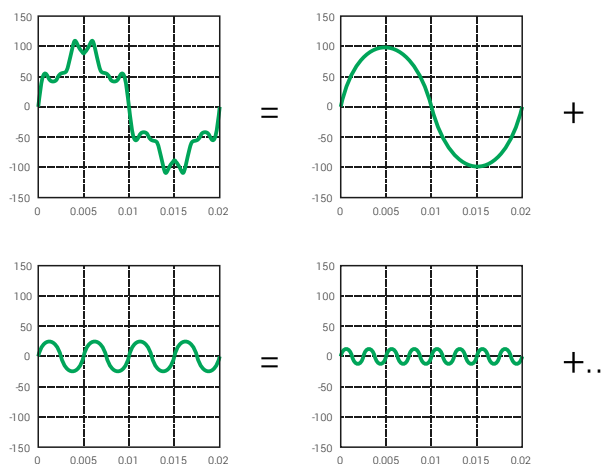

$$I = I_1 + I_2 + I_3 + \dots + I_n$$

It is not advisable to install the power factor correction without considering the harmonic content of a system. This is because, even if we could manufacture capacitors that can withstand high overloads, capacitors produce an increase of harmonic content, with the negative effects just seen.

We speak about resonance phenomena when an inductive reactance is equal to the capacitive one:

$$2\pi f L = \frac{1}{2\pi f C}$$

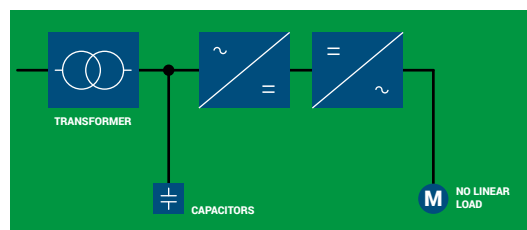

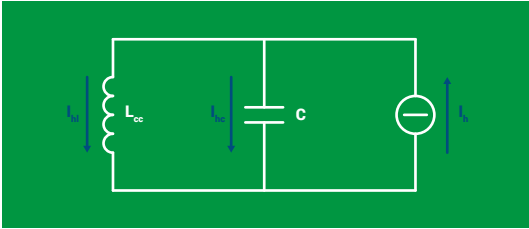

Ideal current generator represents motor as harmonic current components generator I_h , these are independent from circuit inductance, while L_{cc} is obtainable by capacitor upstream short circuit power (in general it is equal to transformer short-circuit inductance).

The resonance frequency is obtained as follows:

$$N = \sqrt{\frac{S_{cc}}{Q}} \approx \sqrt{\frac{A \cdot 100}{Q \cdot V_{cc}\%}}$$

where

- S_{cc} = short-circuit power of the network (MVA)
- Q = output of power factor correction bank (kvar)
- A = rated power transformer (kVA)
- $V_{cc}\%$ = transformer short-circuit voltage
- N = resonance harmonic order

In parallel resonance conditions the current and the voltage of the circuit $L_{cc} - C$ are heavily amplified as well as the nearby harmonic currents.

Hereinafter an example:

- $A = 630\text{kVA}$ (rated power transformer)
- $V_{cc}\% = 6$ (transformer short-circuit voltage %)
- $Q = 300\text{kvar}$ (output of power factor correction bank)

$$N = \sqrt{\frac{A \cdot 100}{Q \cdot V_{cc}\%}} = \sqrt{\frac{630 \cdot 100}{300 \cdot 6}} \approx 6$$

The result shows that in these conditions the system transformer-capacitor bank has the parallel resonance frequency of 300Hz (6x50Hz). This means likely amplification of 5th and 7th harmonic current.

The most convenient solution to avoid this is the detuned filter, formed introducing a filter reactor in series with the capacitors, making this a more complex resonant circuit but with the desired feature of having a resonance frequency below the first existing harmonic.

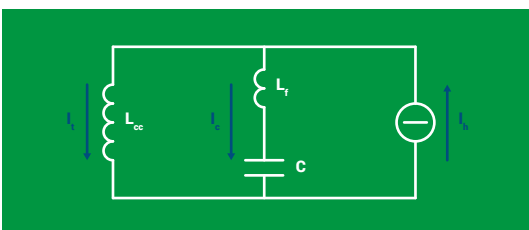
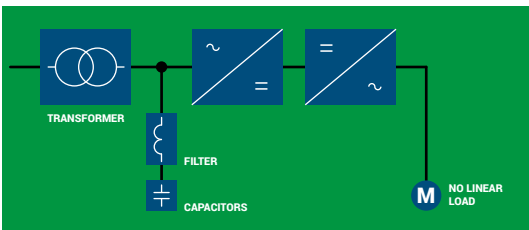

With this type of solution, the parallel resonance frequency is modified from

$$f_{rp} = \frac{1}{2 \cdot \pi \cdot \sqrt{L_{cc} \times C}}$$

to

$$f_{rp} = \frac{1}{2 \cdot \pi \cdot \sqrt{(L_{cc} + L_f) \times C}}$$

Normally the resonance frequency between the capacitor and the series reactance is shifted lower than 250Hz and it is generally between 135Hz and 210Hz. The lower frequencies correspond to higher harmonic loads.

The installation of a reactance in series with the capacitor bank produces a series resonance frequency:

$$f_{rs} = \frac{1}{2 \cdot \pi \cdot \sqrt{L_f \times C}}$$

If a harmonic current I_h with the same frequency of the resonance in series exists, this one will be totally absorbed by the system capacitors - reactors without any effect on the network. The realisation of a tuned passive filter is based on this simple principle.

This application is required when we want the reduction of the total distortion in current (THD) on the system:

$$THD = \frac{\sqrt{I_3^2 + I_5^2 + I_7^2 + \dots + I_n^2}}{I_1}$$

where

- I_1 = component at the fundamental frequency (50Hz) of the total harmonic current
- $I_3 - I_5 - \dots$ = harmonic components at the multiple frequency of the fundamental (150Hz, 250Hz, 350Hz, ...)

The dimensioning of tuned/passive filters is linked to the circuit parameter:

- Impedance of the network (attenuation effect less as the short-circuit power on the network increases: in some cases could be useful to add in series with the network a reactance to increase the filtering effect).
- Presence of further loads that generate harmonics linked to other nodes on the network.
- Capacitor types.

On this last point we have to make some considerations. It is known that the capacitors tend to decrease capacity over time: varying the capacity inevitably varies the resonance series frequency

$$f_{rs} = \frac{1}{2 \cdot \pi \cdot \sqrt{L_f \times C}}$$

and this drawback can be very dangerous because the system could lead in parallel resonance conditions. In this case, the filter does not absorb more harmonics but even amplifies them.

In order to have a constant capacity guarantee over time we need to use another type of capacitors made in bimetalized paper and oil impregnated polypropylene.

In addition to the passive absorption filter realized with capacitors and inductances is possible to eliminate the network harmonics, with another type of absorption filter: the Active Filter. The operation principle is based on the in-line injection of the same current harmonics produced by non-linear loads, but out of phase.

Power factor correction in presence of distorted voltage

In many industrial electrical systems or in the tertiary sector, the presence of non-linear loads (inverter, welding, filament free lamps, computers, drives, etc..) causes a distortion of the current, which is synthesized by the THDI% numeric parameter: if the current is sinusoidal his THDI% is zero, more the current is deformed so much higher is its THDI%.

In electrical currents with very deformed currents, the power factor correction equipment are carried out in a "filter banks" (or "block" or "blocked" or "detuned" if you prefer), or rather with inductors that prevent harmonic current to reach and damage the capacitor.

Usually the supply voltage remains sinusoidal even if a very deformed current flows in the plant; however, if the MV/LV transformer impedance is high, the voltage may also be affected by deformation: this impedance, crossed by a distorted current, will create a voltage drop equally distorted, causing on LV users a non-sinusoidal supply voltage (or with a certain THDV_r%).

It is rare that the THDV_r% reaches 8% (limit of IEC 50160), this happens for example when the MV/LV transformer is characterized by a high series impedance and/or is overloaded (saturation).

In a plant with distorted voltage there will be problems of various types, depending on the utilities (breakage or malfunction of electronic parts such as relays, plc, controller, computers; production beyond the acceptable tolerances, etc.).

Regarding the power factor correction, a high THDV_r% creates problems for the blocking reactors used in power factor correction banks. These can saturate and overheat for overload up to be damaged, causing the out of service of the power factor correction bank and/or problems to the capacitors.

This will result in an economic loss (payment of penalties for low cosφ) and technical, because the plant will run through by a higher current, resulting in conductors additional overhead (cables, bars) and the transformer.

For this problem, ORTEA SpA has developed a dedicated solution: the MULTImatic FV25V (for 400V network) power factor correction range. They are made with metallized polypropylene capacitor with increased thickness with high performance and electronic instrumentation for the electrical parameters control; high linearity reactance allow them to bear up to 8% THDV_r continuously.

Power factor correction in the presence of a photovoltaic system in spot trading

If on electrical plant of an industrial user is added a photovoltaic system, the active power drawn from the supply is reduced because of the power supplied by the photovoltaic system and consumed by the plant (consumption).

Therefore, it changes the relationship between reactive power and active energy drawn from the network and, consequently, the power factor is lower than the same system without photovoltaic.

We must therefore pay particular attention to the power factor correction not to have any penalties for low cosφ that could seriously erode the economic benefits of the photovoltaic system.

The power factor correction will be reviewed both for installed capacity, both for construction type. In fact, increasing the power factor corrector power, you will modify the resonance conditions with the MV/LV transformer which supply the system.

When the photovoltaic system has more power than the users one, or if it is possible that power is introduced to the network, the power factor corrector must also be able to run on the four quadrants. The two "standard" quadrants are related to the plant operation as a user that absorbs from the network both active and inductive reactive power, while the two quadrants related on the plant functioning as a generator, it provides the network active power, but it absorbs the inductive reactive power (quadrants of generation).

All ICAR range of cosφ electronic controllers are able to operate in four quadrants, running two different cosφ targets to optimize the system economic performance.

To manage the cogeneration quadrants you can alter some parameters settings. It is advisable to enter a value equal to 1, to optimize the yield of the PFC Bank. Refer to the manuals of the controllers for more details.

To get the maximum benefit in the time allowed by the PFC Bank, we recommend to use metallized polypropylene capacitor with increased thickness.

APPENDIX

Table 1

K factor for turning active power into reactive power to achieve target power factor.

Starting power factor	Target power factor										
	0,90	0,91	0,92	0,93	0,94	0,95	0,96	0,97	0,98	0,99	1,00
0,30	2,695	2,724	2,754	2,785	2,817	2,851	2,888	2,929	2,977	3,037	3,180
0,31	2,583	2,611	2,641	2,672	2,704	2,738	2,775	2,816	2,864	2,924	3,067
0,32	2,476	2,505	2,535	2,565	2,598	2,632	2,669	2,710	2,758	2,818	2,961
0,33	2,376	2,405	2,435	2,465	2,498	2,532	2,569	2,610	2,657	2,718	2,861
0,34	2,282	2,310	2,340	2,371	2,403	2,437	2,474	2,515	2,563	2,623	2,766
0,35	2,192	2,221	2,250	2,281	2,313	2,348	2,385	2,426	2,473	2,534	2,676
0,36	2,107	2,136	2,166	2,196	2,229	2,263	2,300	2,341	2,388	2,449	2,592
0,37	2,027	2,055	2,085	2,116	2,148	2,182	2,219	2,260	2,308	2,368	2,511
0,38	1,950	1,979	2,008	2,039	2,071	2,105	2,143	2,184	2,231	2,292	2,434
0,39	1,877	1,905	1,935	1,966	1,998	2,032	2,069	2,110	2,158	2,219	2,361
0,40	1,807	1,836	1,865	1,896	1,928	1,963	2,000	2,041	2,088	2,149	2,291
0,41	1,740	1,769	1,799	1,829	1,862	1,896	1,933	1,974	2,022	2,082	2,225
0,42	1,676	1,705	1,735	1,766	1,798	1,832	1,869	1,910	1,958	2,018	2,161
0,43	1,615	1,644	1,674	1,704	1,737	1,771	1,808	1,849	1,897	1,957	2,100
0,44	1,557	1,585	1,615	1,646	1,678	1,712	1,749	1,790	1,838	1,898	2,041
0,45	1,500	1,529	1,559	1,589	1,622	1,656	1,693	1,734	1,781	1,842	1,985
0,46	1,446	1,475	1,504	1,535	1,567	1,602	1,639	1,680	1,727	1,788	1,930
0,47	1,394	1,422	1,452	1,483	1,515	1,549	1,586	1,627	1,675	1,736	1,878
0,48	1,343	1,372	1,402	1,432	1,465	1,499	1,536	1,577	1,625	1,685	1,828
0,49	1,295	1,323	1,353	1,384	1,416	1,450	1,487	1,528	1,576	1,637	1,779
0,50	1,248	1,276	1,306	1,337	1,369	1,403	1,440	1,481	1,529	1,590	1,732
0,51	1,202	1,231	1,261	1,291	1,324	1,358	1,395	1,436	1,484	1,544	1,687
0,52	1,158	1,187	1,217	1,247	1,280	1,314	1,351	1,392	1,440	1,500	1,643
0,53	1,116	1,144	1,174	1,205	1,237	1,271	1,308	1,349	1,397	1,458	1,600
0,54	1,074	1,103	1,133	1,163	1,196	1,230	1,267	1,308	1,356	1,416	1,559
0,55	1,034	1,063	1,092	1,123	1,156	1,190	1,227	1,268	1,315	1,376	1,518
0,56	0,995	1,024	1,053	1,084	1,116	1,151	1,188	1,229	1,276	1,337	1,479
0,57	0,957	0,986	1,015	1,046	1,079	1,113	1,150	1,191	1,238	1,299	1,441
0,58	0,920	0,949	0,979	1,009	1,042	1,076	1,113	1,154	1,201	1,262	1,405
0,59	0,884	0,913	0,942	0,973	1,006	1,040	1,077	1,118	1,165	1,226	1,368
0,60	0,849	0,878	0,907	0,938	0,970	1,005	1,042	1,083	1,130	1,191	1,333
0,61	0,815	0,843	0,873	0,904	0,936	0,970	1,007	1,048	1,096	1,157	1,299
0,62	0,781	0,810	0,839	0,870	0,903	0,937	0,974	1,015	1,062	1,123	1,265
0,63	0,748	0,777	0,807	0,837	0,870	0,904	0,941	0,982	1,030	1,090	1,233
0,64	0,716	0,745	0,775	0,805	0,838	0,872	0,909	0,950	0,998	1,058	1,201
0,65	0,685	0,714	0,743	0,774	0,806	0,840	0,877	0,919	0,966	1,027	1,169
0,66	0,654	0,683	0,712	0,743	0,775	0,810	0,847	0,888	0,935	0,996	1,138
0,67	0,624	0,652	0,682	0,713	0,745	0,779	0,816	0,857	0,905	0,966	1,108
0,68	0,594	0,623	0,652	0,683	0,715	0,750	0,787	0,828	0,875	0,936	1,078
0,69	0,565	0,593	0,623	0,654	0,686	0,720	0,757	0,798	0,846	0,907	1,049
0,70	0,536	0,565	0,594	0,625	0,657	0,692	0,729	0,770	0,817	0,878	1,020
0,71	0,508	0,536	0,566	0,597	0,629	0,663	0,700	0,741	0,789	0,849	0,992
0,72	0,480	0,508	0,538	0,569	0,601	0,635	0,672	0,713	0,761	0,821	0,964
0,73	0,452	0,481	0,510	0,541	0,573	0,608	0,645	0,686	0,733	0,794	0,936
0,74	0,425	0,453	0,483	0,514	0,546	0,580	0,617	0,658	0,706	0,766	0,909
0,75	0,398	0,426	0,456	0,487	0,519	0,553	0,590	0,631	0,679	0,739	0,882
0,76	0,371	0,400	0,429	0,460	0,492	0,526	0,563	0,605	0,652	0,713	0,855
0,77	0,344	0,373	0,403	0,433	0,466	0,500	0,537	0,578	0,626	0,686	0,829
0,78	0,318	0,347	0,376	0,407	0,439	0,474	0,511	0,552	0,599	0,660	0,802
0,79	0,292	0,320	0,350	0,381	0,413	0,447	0,484	0,525	0,573	0,634	0,776
0,80	0,266	0,294	0,324	0,355	0,387	0,421	0,458	0,499	0,547	0,608	0,750
0,81	0,240	0,268	0,298	0,329	0,361	0,395	0,432	0,473	0,521	0,581	0,724
0,82	0,214	0,242	0,272	0,303	0,335	0,369	0,406	0,447	0,495	0,556	0,698
0,83	0,188	0,216	0,246	0,277	0,309	0,343	0,380	0,421	0,469	0,530	0,672
0,84	0,162	0,190	0,220	0,251	0,283	0,317	0,354	0,395	0,443	0,503	0,646
0,85	0,135	0,164	0,194	0,225	0,257	0,291	0,328	0,369	0,417	0,477	0,620
0,86	0,109	0,138	0,167	0,198	0,230	0,265	0,302	0,343	0,390	0,451	0,593
0,87	0,082	0,111	0,141	0,172	0,204	0,238	0,275	0,316	0,364	0,424	0,567
0,88	0,055	0,084	0,114	0,145	0,177	0,211	0,248	0,289	0,337	0,397	0,540
0,89	0,028	0,057	0,086	0,117	0,149	0,184	0,221	0,262	0,309	0,370	0,512
0,90	-	0,029	0,058	0,089	0,121	0,156	0,193	0,234	0,281	0,342	0,484
0,91	-	-	0,030	0,060	0,093	0,127	0,164	0,205	0,253	0,313	0,456
0,92	-	-	-	0,031	0,063	0,097	0,134	0,175	0,223	0,284	0,426
0,93	-	-	-	-	0,032	0,067	0,104	0,145	0,192	0,253	0,395
0,94	-	-	-	-	-	0,034	0,071	0,112	0,160	0,220	0,363
0,95	-	-	-	-	-	-	0,037	0,078	0,126	0,186	0,329

Power factor correction of transformers MV/LV.

Power transformer [kVA]	Standard		Low losses	
	Oil [kvar]	Resin [kvar]	Oil [kvar]	Resin [kvar]
10	1	1,5	–	–
20	2	1,7	–	–
50	4	2	–	–
75	5	2,5	–	–
100	5	2,5	1	2
160	7	4	1,5	2,5
200	7,5	5	2	2,5
250	8	7,5	2	3
315	10	7,5	2,5	3,5
400	12,5	8	2,5	4
500	15	10	3	5
630	17,5	12,5	3	6
800	20	15	3,5	6,5
1000	25	17,5	3,5	7
1250	30	20	4	7,5
1600	35	22	4	8
2000	40	25	4,5	8,5
2500	50	35	5	9
3150	60	50	6	10

Power factor correction of asynchronous three-phase motors.

Attention to possible self-excitation.

Motor power		Required reactive power [kvar]				
HP	KW	3000 rpm	1500 rpm	1000 rpm	750 rpm	500 rpm
0,4	0,55	–	–	0,5	0,5	–
1	0,73	0,5	0,5	0,6	0,6	–
2	1,47	0,8	0,8	1	1	–
3	2,21	1	1	1,2	1,6	–
5	3,68	1,6	1,6	2	2,5	–
7	5,15	2	2	2,5	3	–
10	7,36	3	3	4	4	5
15	11	4	5	5	6	6
30	22,1	10	10	10	12	15
50	36,8	15	20	20	25	25
100	73,6	25	30	30	30	40
150	110	30	40	40	50	60
200	147	40	50	50	60	70
250	184	50	60	60	70	80

Typical Power Factor of few common loads.

Type of user	cosφ	
Equipment powered by inverter	0,99	
Office appliances (computers, printers, etc)	0,7	
Fridges	0,8	
Commercial mall	0,85	
Office block	0,8	
Extruders	0,4÷0,7	
Resistor furnaces	1	
Arc furnaces	0,8	
Induction furnaces	0,85	
Photovoltaic system in spot trading	0,1÷0,9	
Incandescent lamps	1	
Discharge lamps	0,4÷0,6	
Fluorescent lamps without integrated PFC	0,5	
Fluorescent lamps with integrated PFC	0,9÷0,93	
LED lamps without integrated PFC	0,3÷0,6	
LED lamps with integrated PFC	0,9÷0,95	
Asynchronous motor	Load factor	
	0	0,2
	25%	0,55
	50%	0,72
	75%	0,8
100%	0,85	
Mechanical workshop	0,6÷0,7	
Wooden workshop	0,7÷0,8	
Hospital	0,8	
Glassworks	0,8	



Companies are more and more sensitive to Power Quality issues because they can cause troubles and damages to equipments.

Our Power Quality solutions:

VOLTAGE STABILISERS
SAG COMPENSATOR
LV TRANSFORMERS
PFC SYSTEMS
ACTIVE HARMONIC FILTERS
ENERGY EFFICIENCY SMART DEVICES



ORTEA SpA

Via dei Chiosi, 21
 20873 Cavenago di Brianza MB | ITALY
 tel. +39 02 95 917 800

www.next.ortea.com
sales@ortea.com

The present document is reserved property of ORTEA SpA:

it is compulsory to inform head office and ask for authorisation before proceeding with any release or reproduction. ORTEA SpA will not be held liable or responsible in any way for unauthorised copies, alterations or additions to the next or to the illustrated parts of this document. Any modification involving company logo, certification symbols, names and official data is strictly forbidden.

In order to obtain better performance, ORTEA SpA reserves also the right to alter the products described in this document at any date and without prior notice. Technical data and descriptions do not therefore have any contractual value.