

LINEAR ACTUATORS ELECTRONIC DRIVERS

TECHNICAL CATALOGUE



CE IP65



MecVel[®]

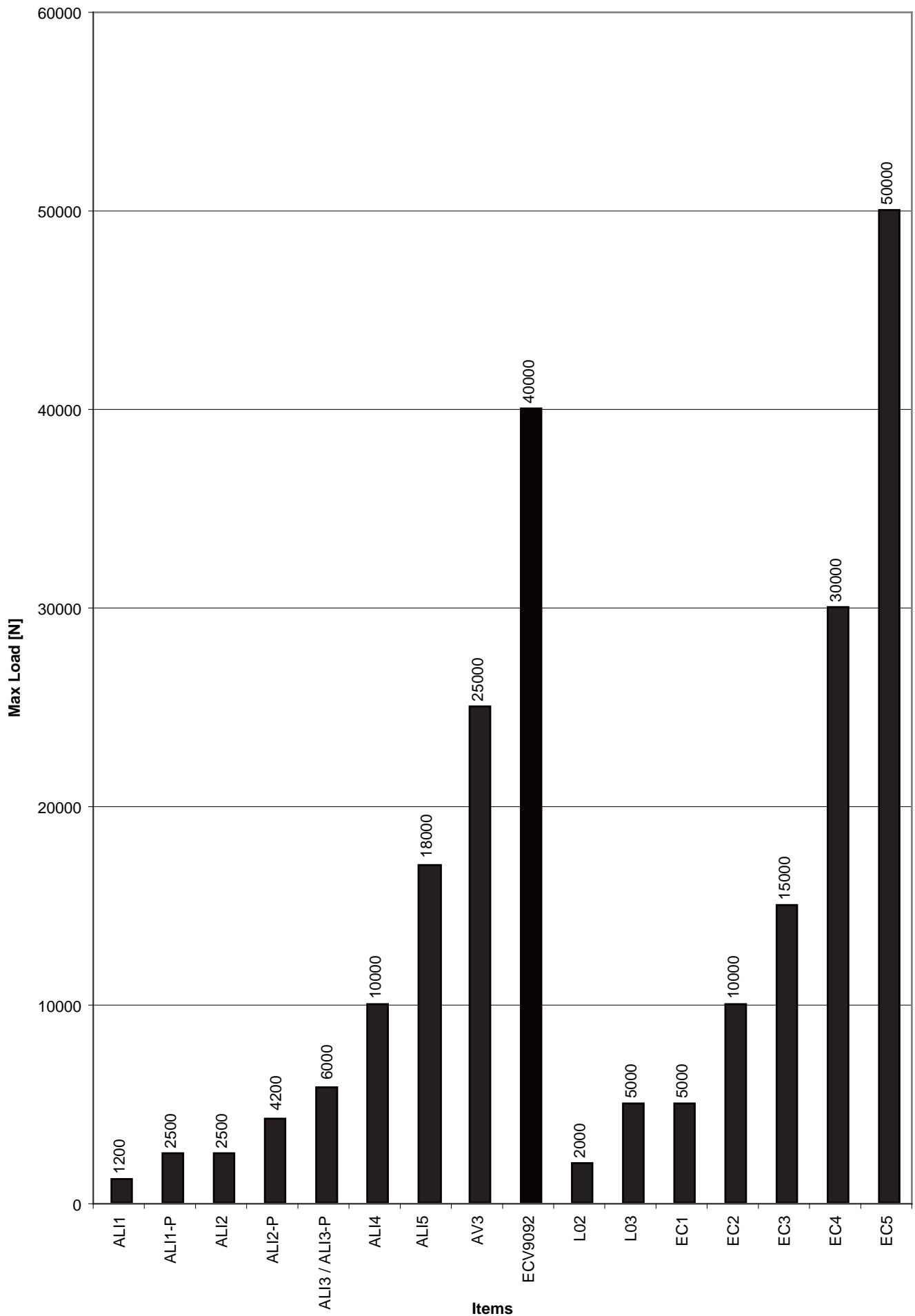

LINEAR ACTUATORS ELECTRONIC DRIVERS

Linear actuators
and gear boxes selection criteria **4**



ALI 1 **13**
Max force: 1.200 N
Max speed: 90 mm/s
DC



ALI 1-P **17**
Max force: 2.500 N
Max speed: 16,5 mm/s
DC



ALI 2 **21**
Max force: 2.500 N
Max speed: 110 mm/s
AC/DC



ALI 2-P **25**
Max force: 4.200 N
Max speed: 30 mm/s
DC

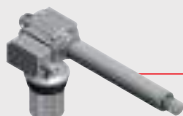

ALI 3 **29**
Max force: 6.000 N
Max speed: 35 mm/s
AC/DC



ALI 3-P **33**
Max force: 6.000 N
Max speed: 35 mm/s
DC



ALI 4 **37**
Max force: 10.000 N
Max speed: 100 mm/s
AC/DC



ALI 5 **41**
Max force: 18.000 N
Max speed: 93 mm/s
AC



ALI 5-P / ALI 5-PB **45**
Max force: 15.000 N
Max speed: 220 mm/s
AC



AV 3 **49**
Max force: 25.000 N
Max speed: 55 mm/s
AC



ECV 9092 **53**
Max force: 40.000 N
Max speed: 45 mm/s
AC



L0 2 **57**
Max force: 2.000 N
Max speed: 100 mm/s
DC



L0 3 **61**
Max force: 5.000 N
Max speed: 30 mm/s
DC



EC **65**
Max force: 5.000 N - ... - 50.000 N
Max speed: 230 mm/s - ... - 15 mm/s
AC

Accessories and options **71**

Sales conditions **100**

LINEAR ACTUATORS AND GEAR BOXES SELECTION CRITERIA



GENERAL WARNING

Actuators and gear boxes are devices meant to be installed into larger machines therefore **they cannot be considered as safety devices** (see EC law CE 89/392 and further CE 91-368,93/44,93/68). They are not elements that shall discriminate, with their use or with their fault, safeguard of people's safety and health. Thus it is not allowed to use MecVel products as safety devices.



INSTALLATION, USE, MAINTENANCE AND WASTE GUIDELINES

MecVel recommendations:

- Actuators and gear boxes being installed by qualified and authorised technicians
- Electrical connections done by qualified personnel; during installation main electric power supply shall be turned off so to run safely all these operations (wearing also protection suits, gloves and glasses)
- Actuators and gear boxes need very few maintenance operations: cleaning and eventually greasing (according to instruction manuals)
- Scheduled inspections to working actuator or gear box in order to detect in time possible problems: in case of doubts contact MecVel
- If something wrong is detected do not try to fix it without MecVel's technical advise: its after-sales dept. will be at your complete disposal to solve it out

All products are delivered with proper packing, according to customer needs and goods dimensions / weight. We recommend a safe product handling, using for example forklifts, safety belts....

Package, as well as the actuators themselves, shall be disposed / wasted according to laws in force in the user's Country.

INTRODUCTION

Linear actuators are independent systems used to obtain linear movements: basically, they are made up by an electric motor, rotating a lead screw directly or by means of a gearbox.

A nut is then allowed to move along the lead screw carrying in and out a push rod connected to the nut itself.

Load shall be axial only, but it can be tensile or pushing, no matter what push rod direction is. Actuators can work both with or without load. Self-locking or not self-locking behaviour depend on the gearing ratio and load value. In any case, self-locking is always possible with additional components.

According to type of actuator and driving / control system used with it, we can have a simple ON / OFF device (pushing and/or pulling) or a servo-mechanism.

Electric actuators main advantages towards pneumatic and hydraulic ones are basically following:

they can easily stop in intermediate positions all along their stroke,

the power consumption happens only while the actuator is working (not necessary to keep it in position for example), the power supply is clean and easy to find, with no need of tubes.

Thus, wirings on applications frameworks will be easier to build and no fluids (i.e. oil) can accidentally be spared. This last feature is necessary in food and textile environments.

ACTUATOR MAIN COMPONENTS

Linear actuators consist in an electric motor directly connected to lead-screw/nut or by means of a worm gearbox, a belt/pulleys system or planetary gearings (1 or 2 stages).

The system turns out to be a rigid chain.



Running against mechanical stops causes serious damages to actuator's internal parts!

Motors

Actuators can host different kinds of motors: AC three or single phase, with brake, inverter-friendly, DC, brushless and stepper-motors. Many options are available such as second shafts, manual brake release and so on.

Selection of motor performances (torque, speed, service...) is done according to duty cycle requested to actuators.

Gear-boxes

Two kinds of gear-boxes are basically used on actuators too:

- Steel worm-screw (1 or 2 stages) and plastic or bronze worm-wheel: wheel's material is chosen according to needed main performances such as low noise, lifetime, reduced backlash
- Planetary gear-box (ALI5-AP, L and EC series): due to its high efficiency this kind is often used when duty cycles are high. They can have 1 stage with plastic satellites or 2 stages where first one has plastic satellites and second stage has steel ones

Lead screw

Basically steel made and featuring cold-rolled profile, they are coupled with bronze or plastic polymer in order to grant safety and sturdiness against loads.

In ball-screw versions (VRS), lead screws are cold-rolled and tempered and coupled with hardened-grinded ball-nuts.

Push rod

Push rods can be aluminium made for actuators whose loads are low, thick chrome-plated steel for those who stand high loads or stainless steel for special applications like in food industries.

ACTUATOR AND GEAR BOX APPLICATION FIELDS

Actuators and gear boxes can be used in several fields and various machineries. To give an example of how different can be the applications needing actuators we can list a few like: adjusting brushes height in floor-sweeping machines, positioning blades for wood-cutting machines, textile industries, paint and chemical plants, medical equipment (different movements in X-ray machines) equipments for disabled / aged people, solar panels, etc..

PARAMETERS FOR ACTUATOR OR GEAR BOX SELECTION PROCESS

The main features for actuator or gear box selection are:

- load dynamics (load trend along stroke)
- speed (linear speed trend along stroke)
- duty cycle
- environmental conditions
- stroke length
- power supply
- output rpm (gear box)
- output torque (gear box)

The configuration we get will be self-locking or non-self-locking according to its global efficiency.

Load and linear speed

These two parameters shall be evaluated both separately and together since they may affect each other during actuator working cycle, especially if additional elements like inertial phenomena, vibrations ... are involved.

For example, if a heavy load has to be moved with changing speeds involving sharp accelerations and slowdowns, inertial load has to be added to physical load, thus affecting actuator choice.

In these cases please contact our Technical Dept

Temperature working range can also be widened using special materials for some of the actuator components, special lubricants and seals (the same happens for aggressive environments). Of course under-rating of actuator and duty cycle must also be taken under consideration.

In general, ball-screw units are non-self-locking therefore additional devices, such as brakes, can be necessary to lock actuators

Duty cycle and environmental conditions

These parameters also need to be analyzed as linked together.

Duty cycle is defined as percentage rate between on-time and idle-time, on a timeframe of 5 min.

Environment is mainly related to temperature and occasional aggressive agents affecting materials (humidity, dust, acids...). Standard actuators duty cycle is rated in S3-30%, at 30°C ambient temp.

Working temperature range allowed for standard actuators is -10°C / +60°C.

However duty cycle can be raised building up high-efficiency actuators featuring ball-screws and planetary gearboxes, or over sizing the actuator whose ratings will therefore become higher.

Temperature working range can also be widened using special materials for some of the actuator components, special lubricants and seals (the same happens for aggressive environments). Of course under-rating of actuator and duty cycle must also be taken under consideration.

In general, ball-screw units are non-self-locking therefore additional devices, such as brakes, can be necessary to lock actuators.

Actuator working stroke

This feature (standard each 50 mm step) shall be chosen taking under consideration:

- limits tied to high rotation speeds of internal lead screw and to its own weight (in case the actuator is mounted horizontally) (critical Speed diagram is available on any acme screws technical documentation)
- limits linked to lead screw length to avoid buckling problems (see diagram 1 page 10).

Actuator shall than perform its job within its nominal stroke: while designing application / framework, 10mm extra-stroke on both stroke-ends (in and out) shall be included to decrease possibility of going at mechanical stroke.



Running against actuator's mechanical stops causes serious damages to its internal components! In case of strokes 20 times longer than lead screw diameter, 150mm extra stroke shall be included in the design of the actuator so that, when push rod is completely extracted, it has still 150mm more to go: this will give more stiffness to the unit preventing radial backlash.



Excessive radial backlashes lead to side-forces on actuator's axis, thus unexpected wear and lubricant loss, non regular workouts.

Power supply

To choose a suitable actuator it is important to start finding out which kind of electric power supply is available. Not all actuators are prepared for all voltages.

SELF-LOCKING

There is not a sharp threshold between self locking and non-self locking conditions, because this feature is affected by gears wear, type of load, presence of vibrations, mounting position etc ...When in doubt the only way of being sure of actuator behaviour is testing it on the application. When actuator is not self-locking, its positioning precision and repeatability features are lower: in this case, some additional elements are required, such as brakemotors, control/feedback systems or motor short-circuit to achieve magnetic braking effect (for DC motors without brake only)

ACTUATOR AND GEAR BOX INSTALLATION

During machine designing it is extremely important to foresee proper mounting points so that actuator won't have to stand radial forces but axial ones only.

Then, when physically installing actuator into machinery, an accurate alignment of the connecting points is very important to avoid grease losses and nut wear due to radial forces.

Axis of front and back connecting points must always be parallel.

Actuators shall work within their nominal stroke.

When framework is being designed, 10mm extra stroke (in both directions) must be considered to have less possibilities of mechanical end-stops.

Also, when stroke is 20 times longer than lead screw diameter, at least 150mm extra stroke (in extracted position) shall be included in order to prevent the actuator from having radial forces when push rod is completely out.



Running against mechanical stop causes serious damages to actuator components!



Off-set load lead to side-forces on actuator axis causing unexpected wear, lubricant loss and non-regular operation.

Before starting the actuators or gear box up, following checkings shall be performed:

- If actuator is equipped with limit switches devices, before starting the motor, ensure they are connected and working, in order to avoid any mechanical end-stops.

- Make sure push rod will start travelling in the correct direction and limit switches are correctly adjusted. Start motor "step-by-step" to check all this.



All wirings of actuator (motor and stroke control devices) must be done with power switched off. If not, both operator and actuator are at risk.



When actuators are equipped with single-phase motors, capacitors must be discharged before any operation.



In case limit switches are already adjusted, be careful because manual rotation of push-rod will cause adjustment loss!

For a correct selection of actuators it is absolutely necessary to refer to above reported instructions and technical advises.

MecVel declines any responsibility related to damages caused to things and persons due to not proper use of the technical information given on this catalogue or incorrect use of actuators and gear boxes.

More information about installation of the actuators are reported in the use and maintenance manual.

SERVICE

All actuators with max load lower than AL15 are long-life lubricated:

no relubrication is needed in case actuators workout is regular.

Other models are equipped with lubricators and schedules for service are advised into user manual for each actuator.

<i>Standard lubricant</i>							
Brand	Products	Tmin °C	Tmax °C	Tdrop °C	Base oil	Thickener	NLGI Class
Vanguard	G.S. Friction 2	-45	+150	+180	Synthetic	Lithiumm hydroxide	2

<i>Alternative lubricants</i>							
Brand	Products	Tmin °C	Tmax °C	Tdrop °C	Base oil	Thickener	NLGI Class
Klueber	Isoflex LDS 18 Special A	-50	+120	190	Synthetic	Lithiumm complex	2
Dow Corning	Molykote BG20	-45	+180	+290	Synthetic	Lithiumm complex	2

Dedicated lubricants are available for special duties or special environments (e.g. food machineries); please contact our tech. Department.

Nut wear check-up

A scheduled check on nut wear is to be done periodically.

Wire-off motor and put load on push-rod : load value shall be according to model rating (from nominal load till 0,1 times nominal load lowering this coefficient as the actuator size increases).

Applying both compression and tensile load, check by means of an adial-gauge that axial backlash is lower:

$$Backlash_{(mm)} \leq 0.25 * \frac{screwpitch_{(mm)}}{starts}$$

In case backlash is higher actuator needs to be replaced.

If actuator features ballscrew drive, nut fail first signal is noise higher than usual.



A scheduled manual check as explained above is anyway necessary to monitor regular and linear nut workout.

More information about maintenance of the actuators are reported in the use and maintenance manual.

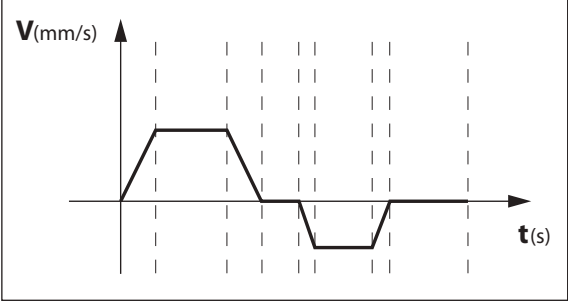

MecVel reserves the right to change products information and/or features without notice; all data contained in this catalogue are purely indicative and not binding for the company.

APPLICATION TECHNICAL SPECS FOR A PROPER ACTUATOR CHOICE

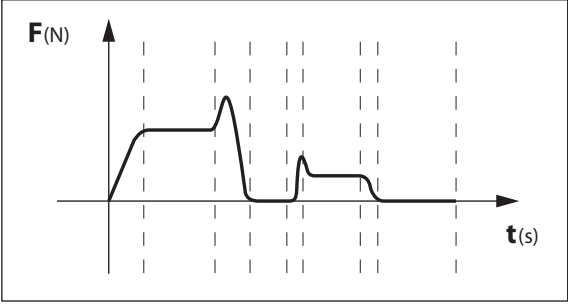
APPLICATION DESCRIPTION:			
POWER SUPPLY Vac Hz	<input type="checkbox"/> SINGLE PHASE <input type="checkbox"/> THREE PHASE
TOTAL LOAD INVOLVED N	ACTUATORS FOR EACH SYSTEM: #	FOR YEAR: #
DYNAMIC PULLING-HANGING LOAD N	DYNAMIC PUSHING LOAD N
STATIC PULLING-HANGING LOAD N	STATIC PUSHING LOAD N
SPEED TIMING:		EXAMPLE:	
			
LOAD TIMING:		EXAMPLE:	
			
(draw an application dimensional outlet)			

Note: in order to perform a proper actuator selection for to your application technical information available in chapter “Electromechanical Actuators + Jack Choice Guideline” must be carefully considered.

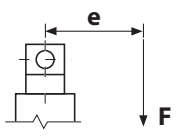
LOAD SPECS:	GUIDED <input type="checkbox"/>	VIBRATING <input type="checkbox"/>	OFF-SET <input type="checkbox"/>		
WORK STROKE: mm	NOMINAL STROKE: mm	SPEED: mm/s
ENVIRONMENT: if aggressive, advise					
.....					
.....					
DUSTY	<input type="checkbox"/>	AGGRESSIVE	<input type="checkbox"/>	HUMIDITY RATE %
				TEMPERATURE GAP: %
DUTY CYCLE: %	CYCLE HOUR:	N°	OPERATING HOURS:	N°
REQUIRED PRECISION IN STOPS:			+/- mm		
STROKE CONTROL:	<input type="checkbox"/>	MECHANICAL LIMIT SWITCHES	N°		
<i>(see more info on catalogue)</i>	<input type="checkbox"/>	MAGNETIC LIMIT SWITCHES	N°		
	<input type="checkbox"/>	POTENTIOMETER	TYPE		
	<input type="checkbox"/>	ENCODER	TYPE		
	<input type="checkbox"/>	ALTRO OTHER	Advise		
REAR END:	TYPE				
<i>(see more info on catalogue)</i>					
FRONT END:	TYPE				
<i>(see more info on catalogue)</i>					
OPTIONS:	<input type="checkbox"/>	ANTI-ROTATION DEVICE	<input type="checkbox"/>	NAKED SCREW	
<i>(see more info on catalogue)</i>	<input type="checkbox"/>	SAFETY NUT	<input type="checkbox"/>	BRONZE WORMWHEEL	
	<input type="checkbox"/>	STAINLESS STEEL LEAD SCREW	<input type="checkbox"/>	DELTRIN (PLASTICS) WORMWHEEL	
	<input type="checkbox"/>	BELLOWS BOOT	<input type="checkbox"/>	VITON SEALS (FOR HI-TEMP DUTIES)	
	<input type="checkbox"/>	PAINTING			
	<input type="checkbox"/>	OTHER (advise)			

For selection/quotation request, please send e-mail to info@mecvel.com

DIAGRAM 1

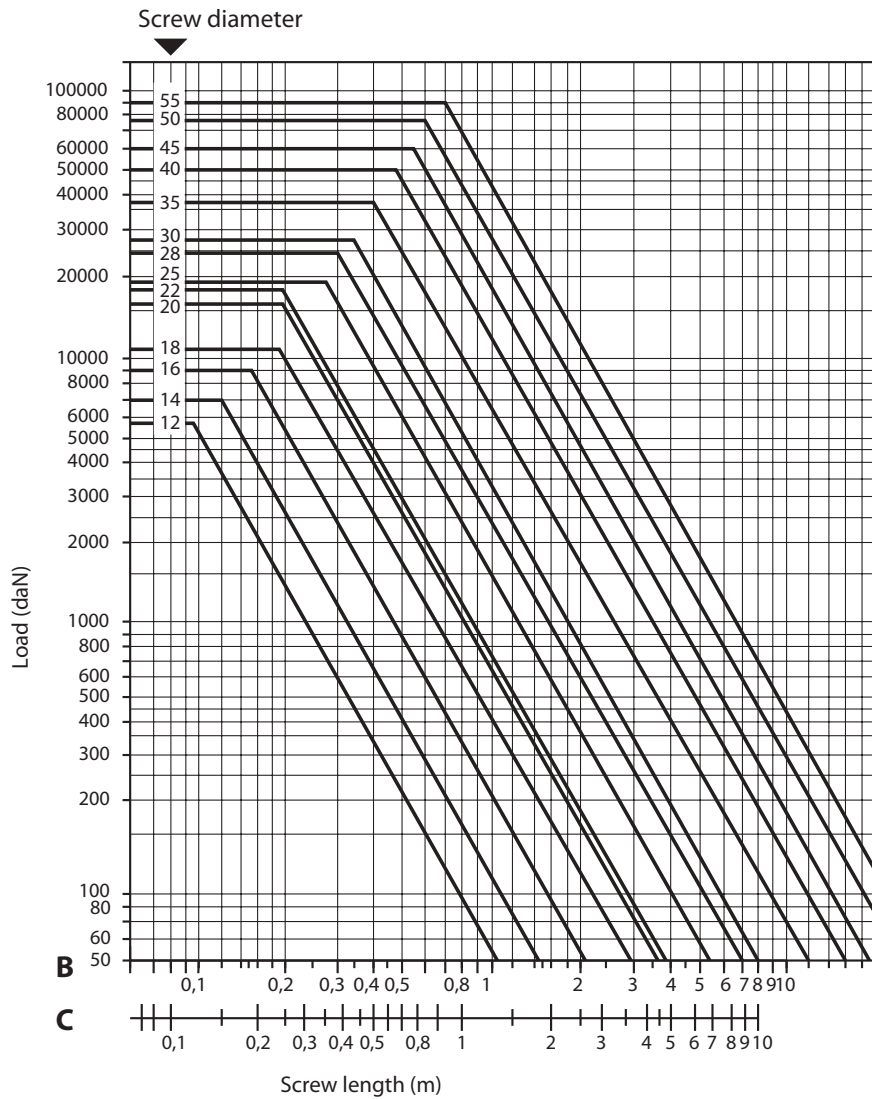

The diagram shows how to see what's max load admitted by lead screw, basing upon its length and upon how actuator will be fixed on frame.

As a general rule, choice is:

Actuator series	Diagram
Actuator with stroke 15-20 time lower than lead screw diameter	C
Actuator with stroke 15-20 time larger than lead screw diameter	B

ALI1 Model C€

- Permanent magnet motor 12 - 24 Vdc
- Double worm gearbox
- ACME lead screw
- Aluminum push rod (Stainless steel on request)
- Permanent grease lubrication
- IP 65, tested according to rule CEI EN 60529
- Working temperature range -10°C +60°C
- Intermittent duty S3 30% (5 min) a 30°C*
- Encoder on request
- Limit switches on request (ALI1-PF)

(*) For any special duty please contact our technical dept.



ALI1 (Vdc)						
Fmax (N)	Speed (mm/s)	Version	Motor size	Motor power (KW)	Motor speed (rpm)	Max Current for Fmax(A) 24Vdc
* 95	90	M12	40S	-	6300	2,8
* 190	90	M13	40L	-	6000	4,5
* 130	60	M10	40S	-	6300	3,1
* 270	60	M11	40L	-	6000	6
* 200	45	M07	40S	-	6300	2,6
* 400	45	M09	40L	-	6000	3,1
290	30	M04	40S	-	6300	2,8
580	30	M06	40L	-	6000	4,5
500	15	M01	40S	-	6300	2,7
1200	15	M03	40L	-	6000	5

**

* When speed is more than 30 mm/s and/or strokes longer than 200 mm, check STROKE SETUP section.

** For 12 Vdc power supply currents are doubled and loads are 20% lower.

BEFORE OPERATING ACTUATOR MAKE SURE YOU READ AND UNDERSTOOD BASIC OPERATIONAL INSTRUCTIONS SHOWN ON USERMANUALS, AVAILABLE FROM WEBSITE.

THIS DOCUMENT DISPLAYS MOST TYPICAL STANDARD FEATURES AND SETUPS: CONTACT OUR OFFICES FOR MORE.

ACTUATOR SHALL NOT COME TO **MECHANICAL STROKE-END**, TO **AVOID FAILURES**.

CONSIDER MECVEL'S LIMITSWITCHES (MODEL ALI1-F) OR PUT THEM ON MACHINE/FRAME.



MecVel reserves the right to change products information and/or features without notice; all data contained in this catalogue are purely indicative and not binding for the company.

ALI1

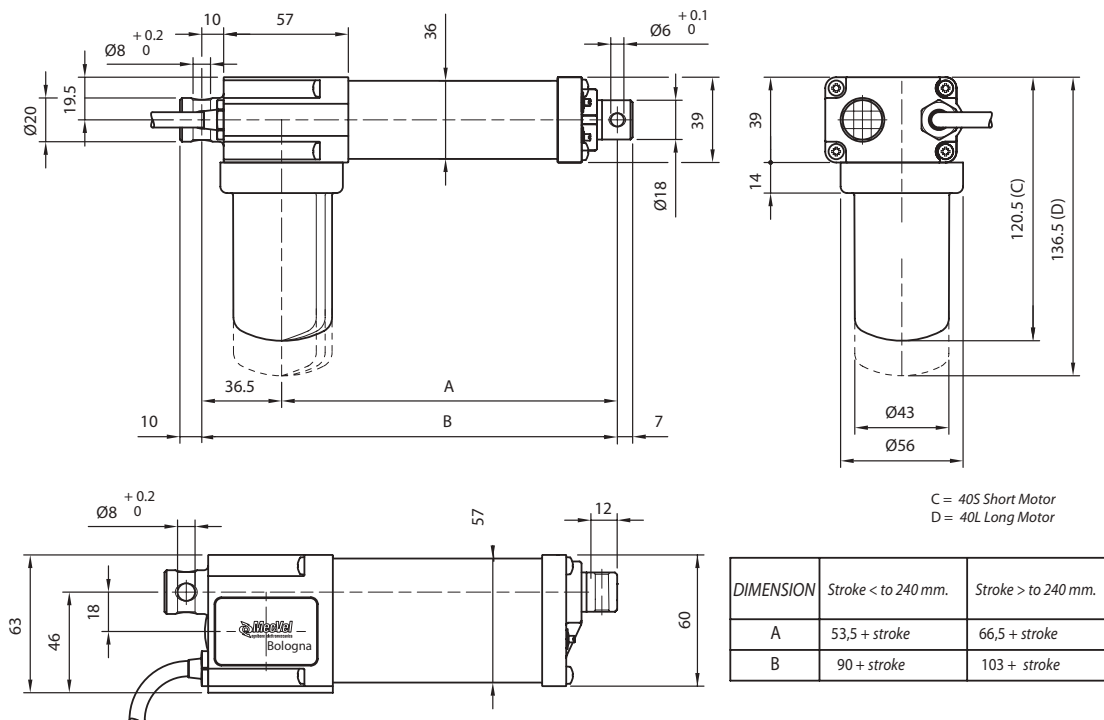

ELECTRICAL WIRINGS

Options available:

- C01/C08 = motor
- C02/C09 = N° 2 microswitches, diode-wired
- C03/C10 = motor + N° 2 micro
- C04/C11 = motor + N° 3 micro
- C05/C12 = motor + encoder
- C06/C13 = N° 2 micro diode wired + encoder
- C07/C14 = motor + N° 2 micro + encoder
- C00 = special wiring (Presence of not standard options)

WARNING:

Micros are actuated by a cam lying on push-rod itself. Micro signal, for speeds higher than 30 mm/s, needs to be handled in its very impulse (I.E. when actuated) and not in its state.

Alternatively, MecVel can add a bush to keep the microswitch lever pressed for a longer time avoiding switch signal mistakes, but cause loss of 10 mm of stroke.

Connections C02 and C06 make a circuit which stops motor supply, so that the push rod won't overstep the area of the two micros.

This system can work only if inertia generated by the actuator and load connected to it does not allow to over-step the micro when stroke is over.

So, this works just with low speeds (M01 - M03), with a load opposing the ongoing direction of the push rod. If not, relay or PLC solutions, using C03 and C07 connections, are needed..Wiring diagrams of connections above are following:

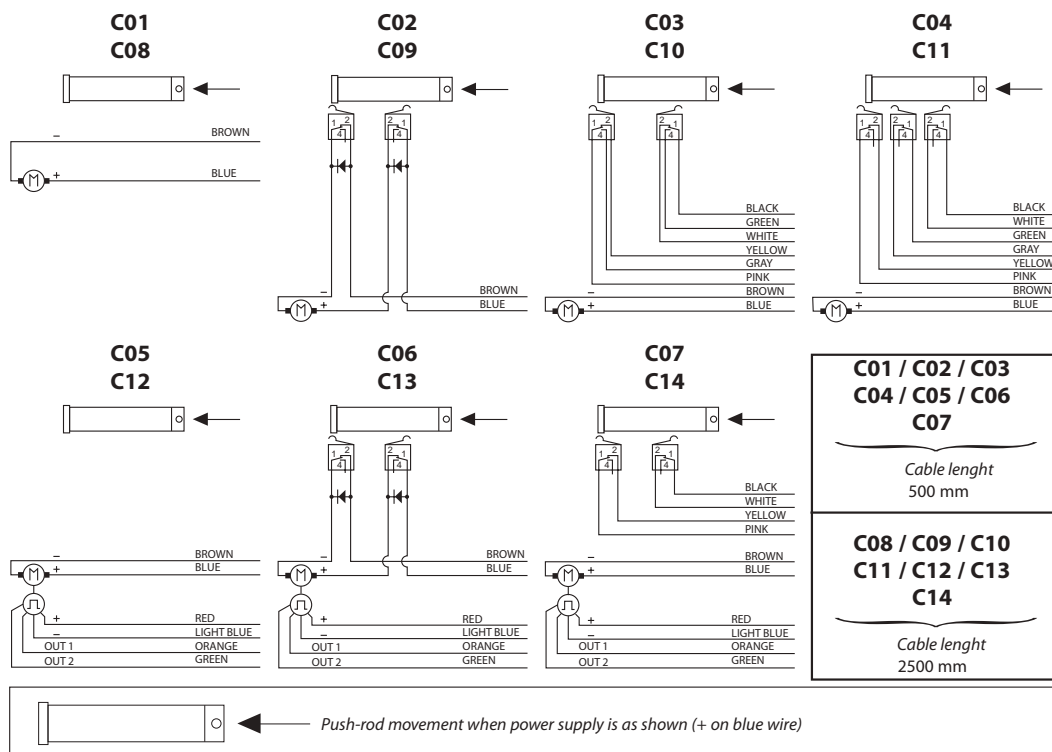

MOTOR POSITION

Motor can be installed on both sides of the actuator, thus achieving two versions, as show below. Actuator is seen from backwards.

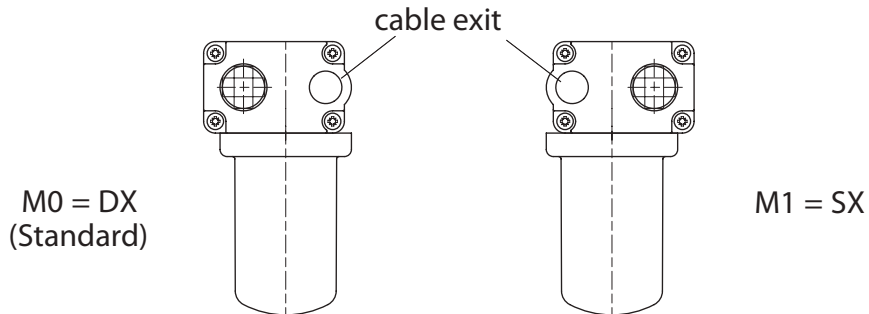

STROKE SETUP: Useful tips for handling stroke and avoid run-on-block collision.

When stroke is more than 350 mm, add 50 mm extra-stroke as guidance, and put corresponding value in ordering-key.

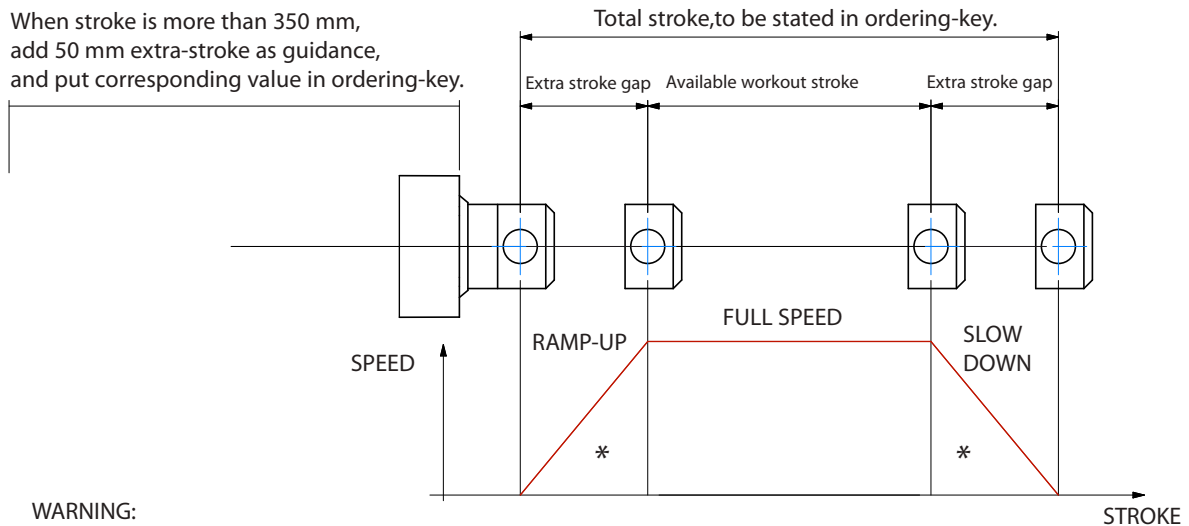

WARNING:

SPEED-TIMING ALONG STROKELENGTH:

ramps are extremely important when speed is >30 mm/s!!! Inverter or PWM drive recommended!

* The more speed raises the more extra stroke has to raise too.

BUCKLING: When stroke is longer than 300mm, BUCKLING can be a risk: please check mounting with our offices and/or see user-manuals.

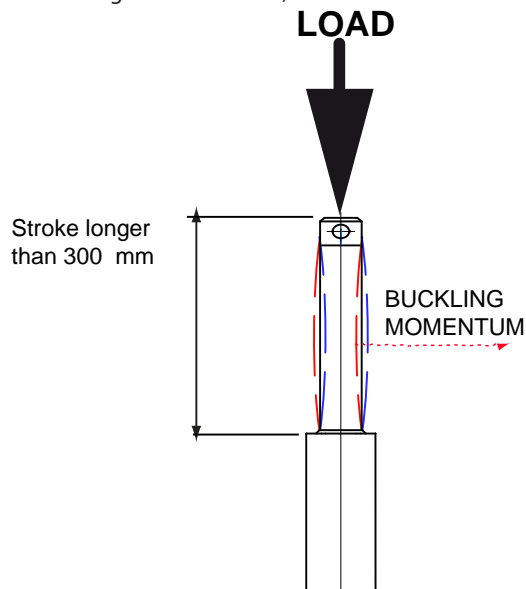

IMPORTANT:

Long strokes, even if load is low, can generate significant buckling momentums, as sketch slows.

This happens when actuator is in its all-opened position: that's the reason why we recommend 100 mm extra-stroke.

Pushtube will have this 100 mm-portion always inside the overtube, improving guidance against buckling.

For more information on this, contact our office.

ORDERING KEY

ALI1F / 0250 / M01 / 12 / M0 / C02 / P1 / A2

MODEL: _____

ALI1 ALI1-F

STROKE: _____

es. 250 mm = 0250

VERSION: _____

M01 / M03 / M04 / M06 / M07 / M09 / M10 / M11 / M12 / M13

M00 = Not standard speed

MOTOR: (available) _____

12 = 12 Vdc

24 = 24 Vdc

MOTOR POSITION: _____

M0 / M1

MOTOR OPTIONS: _____

C01 / C08: Motor

C02 / C09: 2LS Diode wired

C03 / C10: Motor + 2LS

C04 / C11: Motor + 3LS

C05 / C12: Motor + encoder

C06 / C13: 2LS diode wired + encoder

C07 / C14: Motor + encoder + 2LS

C00: Special wiring (Presence of not standard options)

Note: LS (limit switches)

REAR END: _____

P0 = None P1/P2 = standard

FRONT END: _____

A2 = Yoke (Std pag.14)

A3 = Yoke + Clip

A4 = Rod end

A7 = M8x20 male

NOTE: COMPLETE THE ORDERING KEY ADDING THE OPTIONS YOU CAN FIND IN THE "ACCESSORIES AND OPTIONS" SECTION

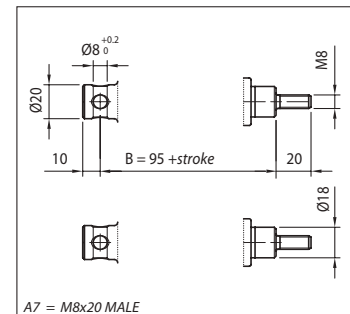
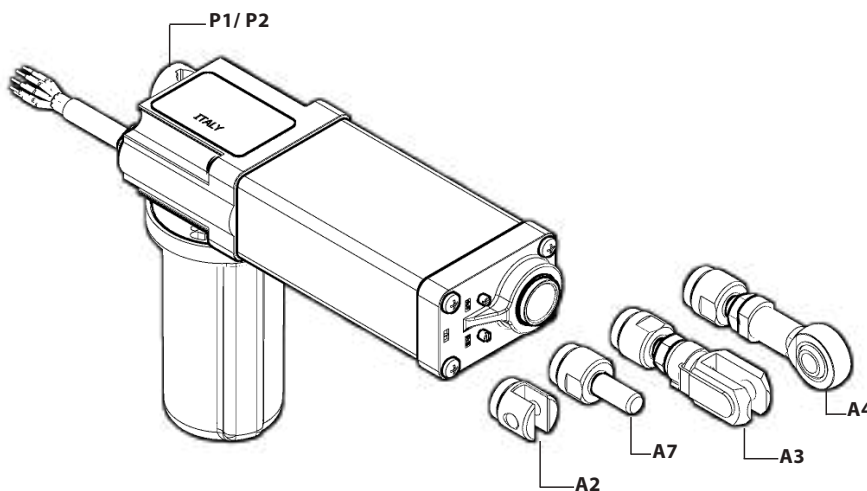

A7 = M8x20 MALE

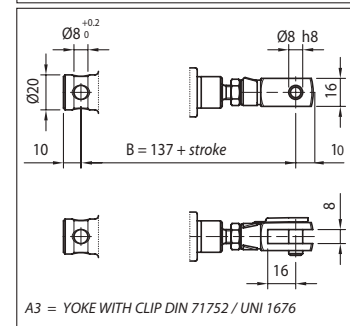

A3 = YOKE WITH CLIP DIN 71752 / UNI 1676

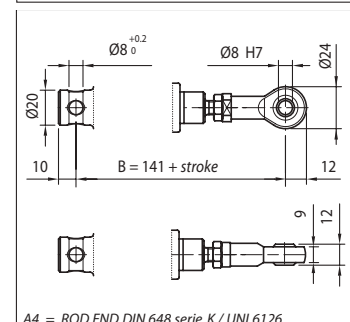

A4 = ROD END DIN 648 serie K / UNI 6126

Note: "B" dimension changes according to model

ALI1-F = See pictures

ALI1-F stroke > 240 mm = + 13 mm

ALI1-P Model C€

- Permanent magnet motor 12 - 24 Vdc
- Double worm gearbox
- ACME lead screw
- Aluminum push rod (Stainless steel on request)
- Permanent grease lubrication
- IP 65, tested according to rule CEI EN 60529
- Working temperature range -10°C +60°C
- Intermittent duty S3 30% (5 min) a 30°C*
- Encoder on request
- Limit switches on request (ALI1-PF)

(*) For any special duty please contact our technical dept.

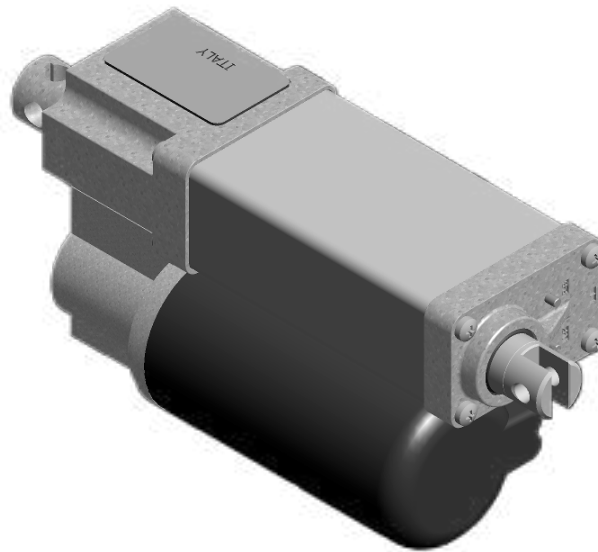

ALI1-P (Vdc)						
Fmax (N)	Speed (mm/s)	Version	Motor size	Motor power (KW)	Motor speed (rpm)	Max Current for F max(A) 24Vcc
1200	16.5	M01	40	-	6000	4,2
1550	11	M02	40	-	6000	3,8
2000	8.3	M03	40	-	6000	3,9
2500	5.6	M04	40	-	6000	3,6
2500	2.8	M05	40	-	6000	2,8
2500	0.9	M06	40	-	6000	1,8

**

When stroke is longer than 200 mm, check STROKE SETUP section.

** For 12 Vdc power supply currents are doubled and loads are 20% lower.

BEFORE OPERATING ACTUATOR MAKE SURE YOU READ AND UNDERSTOOD BASIC OPERATIONAL INSTRUCTIONS SHOWN ON USERMANUALS, AVAILABLE FROM WEBSITE.

THIS DOCUMENT DISPLAYS MOST TYPICAL STANDARD FEATURES AND SETUPS: CONTACT OUR OFFICES FOR MORE.

ACTUATOR SHALL NOT COME TO **MECHANICAL STROKE-END**, TO AVOID **FAILURES**.

CONSIDER MECVEL'S LIMITSWITCHES (MODEL ALI1-PF) OR PUT THEM ON MACHINE/FRAME.



MecVel reserves the right to change products information and/or features without notice; all data contained in this catalogue are purely indicative and not binding for the company.

ALI1-P

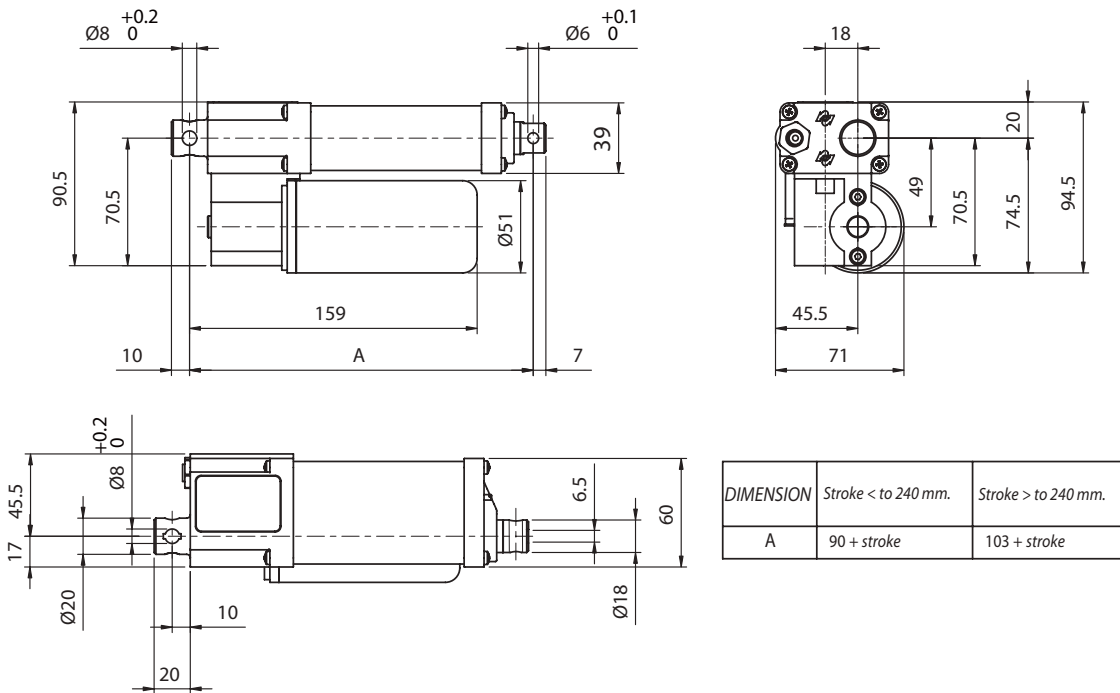

ELECTRICAL WIRINGS

Options available:

- C01/C08 = motor
- C02/C09 = N° 2 microswitches, diode-wired
- C03/C10 = motor + N° 2 micro
- C04/C11 = motor + N° 3 micro
- C05/C12 = motor + encoder
- C06/C13 = N° 2 micro diode wired + encoder
- C07/C14 = motor + N° 2 micro + encoder
- C00 = special wiring (Presence of not standard options)

WARNING:

Micros are actuated by a cam lying on push-rod itself. Micro signal, for high speeds needs to be handled in its very impulse (I.E. when actuated) and not in its state.

Alternatively, MecVel can add a bush to keep the microswitch lever pressed for a longer time avoiding switch signal mistakes, but cause loss of 10 mm of stroke. Connections C02 and C06 make a circuit which stops motor supply, so that the push rod won't overstep the area of the two micros.

This system can work only if inertia generated by the actuator and load connected to it does not allow to over-step the micro when stroke is over.

So, this works just with low speeds (M01 - M03), with a load opposing the ongoing direction of the push rod. If not, relay or PLC solutions, using C03 and C07 connections, are needed.

Wiring diagrams of connections above are following:

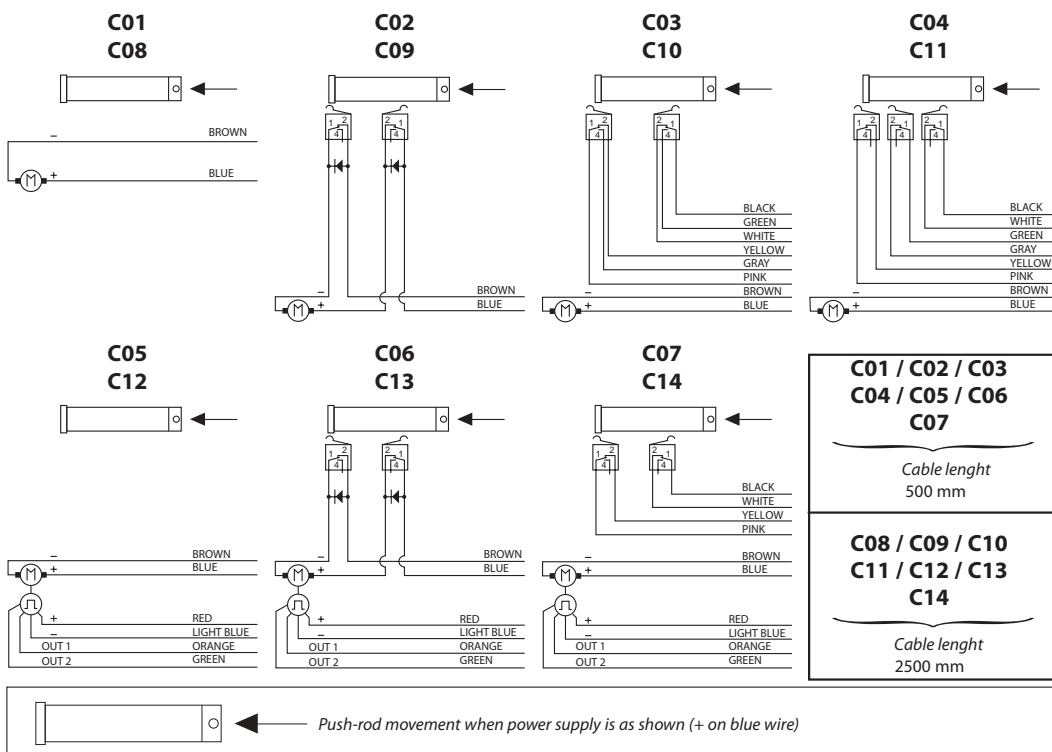

STROKE SETUP: Useful tips for handling stroke and avoid run-on-block collision.

When stroke is more than 350 mm, add 50 mm extra-stroke as guidance, and put corresponding value in ordering-key.

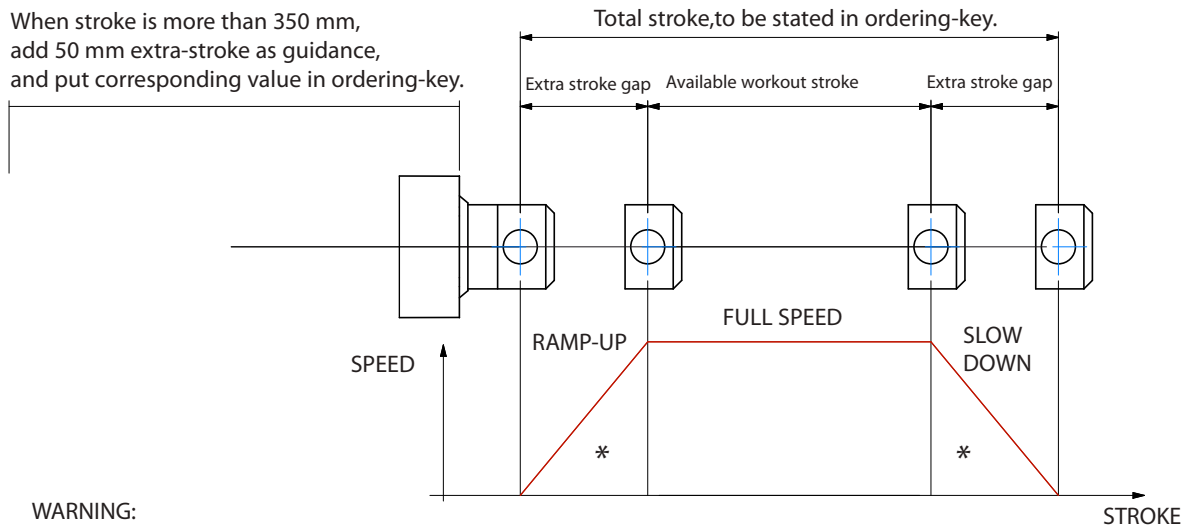

WARNING:
SPEED-TIMING ALONG STROKELENGTH:
 ramps are extremely important with high speed !!! Inverter or PWM drive recommended!
 * The more speed raises the more extra stroke has to raise too.

BUCKLING: With strokes longer than 300mm, BUCKLING can be a risk: please check mounting with our offices and/or see usermanuals.

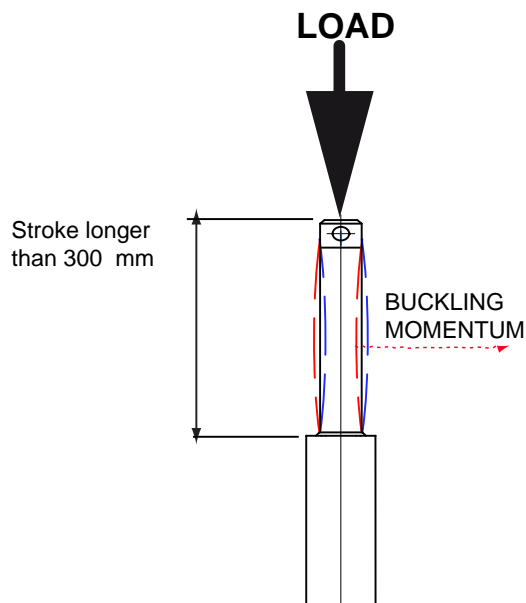

IMPORTANT:
 Long strokes, even if load is low, can generate significant buckling momentums, as sketch slows.
 This happens when actuator is in its all-opened position: that's the reason why we recommend 100 mm extra-stroke.
 Pushtube will have this 100 mm-portion always inside the overtube, improving guidance against buckling.
 For more information on this, contact our office.

ORDERING KEY

ALI1P / 0250 / M01 / 12 / M0 / C02 / P1 / A1

MODEL: _____

ALI1-P (without limit switches) ALI1-PF (with limit switches)

STROKE: _____

es. 250 mm = 0250

VERSION: (pag.17) _____

M01 / M02/ M03 / M04 / M05/ M06

M00 = Not standard speed

MOTOR: (available) _____

12 = 12 Vdc

24 = 24 Vdc

MOTOR POSITION: _____

M0 / M1

MOTOR OPTIONS: _____

C01 / C08: Motore / Motor

C02 / C09: 2LS Diode wired

C03 / C10: Motor + 2LS

C04 / C11: Motor + 3LS

C05 / C12: Motor + encoder

C06 / C13: 2LS diode wired + encoder

C07 / C14: Motor + encoder + 2LS

C00: Special wiring (Presence of not standard options)

Note: LS (limit switches)

REAR END: _____

P0 = None P1 / P2 = standard

FRONT END: _____

A2 = Yoke (Std pag.18)

A3 = Yoke + Clip

A4 = Rod end

A7 = M8x20 male

NOTE: COMPLETE THE ORDERING KEY ADDING THE OPTIONS YOU CAN FIND IN THE "ACCESSORIES AND OPTIONS" SECTION

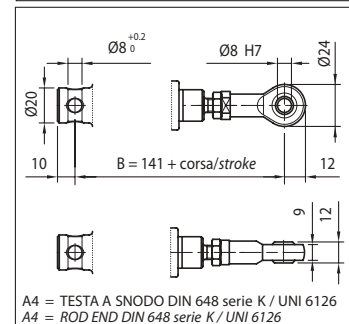
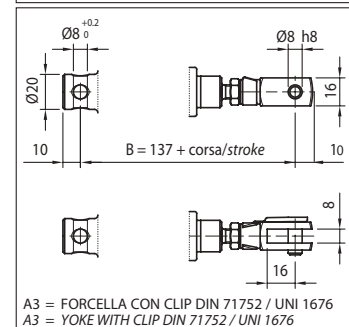
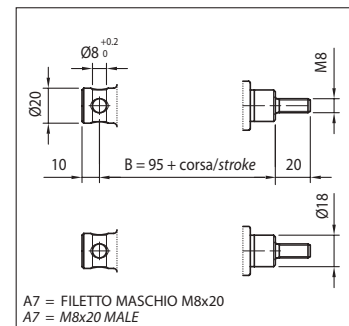
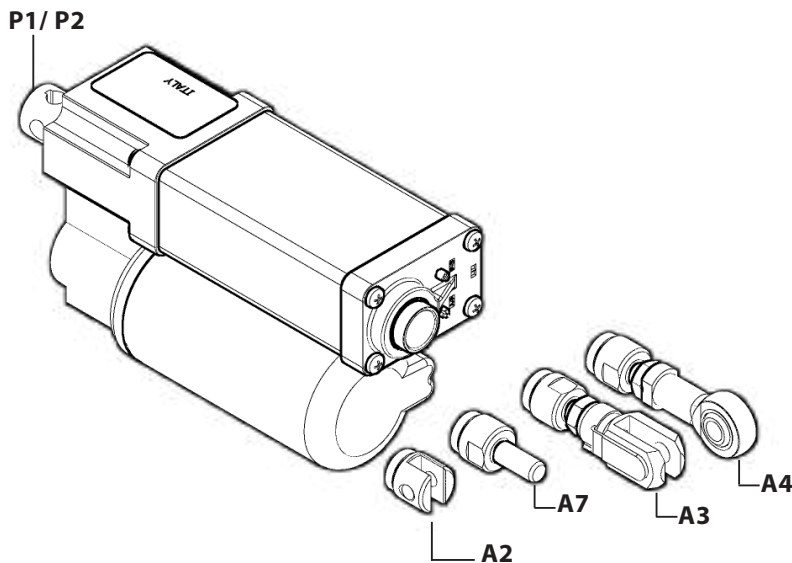

Note: "B" dimension changes according to model

ALI1-PF = See pictures

ALI1-PF stroke > 240 mm = + 13 mm

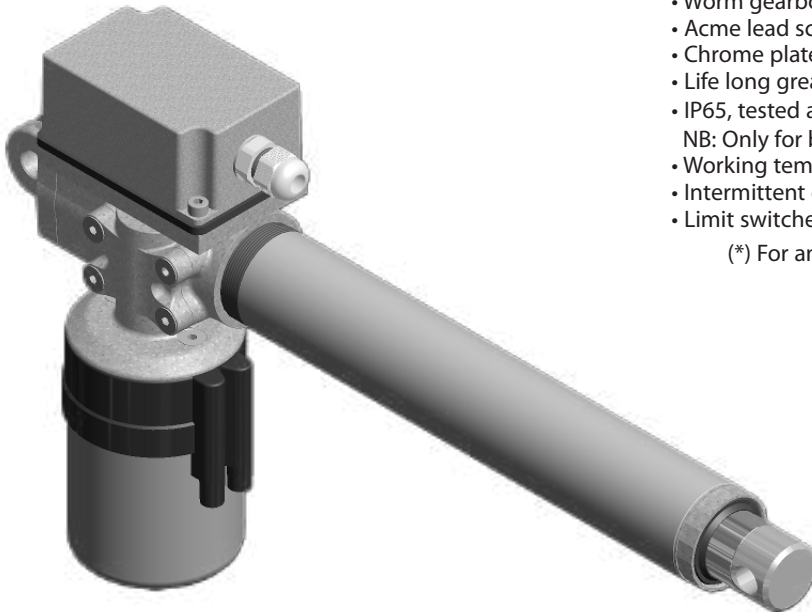

ALI2 Model CE

- Permanent magnet motor CE
 - Three phase or single phase motor CE
 - Worm gearbox
 - Acme lead screw or ballscrew (VRS)
 - Chrome plated steel push rod
 - Life long grease lubricated
 - IP65, tested according to rule CEI EN 60529
 - NB: Only for brake motors Standard IP54, IP65 on request
 - Working temperature range -10°C +60°C
 - Intermittent duty S3 30% (5 min) a +30°C*
 - Limit switches, potentiometer and encoder on request
- (*) For any special duty please contact our technical dept.

ALI2 (Vac 3-phase)					
Fmax (N)	Speed (mm/s)	Version	Motor size	Motor power (KW)	Motor speed (rpm)
* 450	110	M01	IEC50	0.09	2800
* 500	70	M02	IEC50	0.09	2800
* 650	50	M03	IEC50	0.09	2800
* 850	40	M04	IEC50	0.09	2800
1000	30	M05	IEC50	0.06	1400
1400	20	M06	IEC50	0.06	1400
2200	10	M07	IEC50	0.06	1400
2500	5	M08	IEC50	0.06	1400

ALI2 (Vdc)						
Fmax (N)	Speed (mm/s)	Version	Motor size	Motor power (KW)	Motor speed (rpm)	Max Current for Fmax(A) 24Vdc
* 800	110	M08	61.5	-	3000	13
* 850	70	M09	61.5	-	3000	9
* 1100	55	M10	61.5	-	3000	9,5
* 1500	40	M11	61.5	-	3000	11
2000	30	M12	61.5	-	3000	10,5
2500	20	M13	61.5	-	3000	10,5
2500	10	M14	61.5	-	3000	9,5

ALI2 VRS (ballscrew) (Vac 3-phase)					
Fmax (N)	Speed (mm/s)	Version	Motor size	Motor power (KW)	Motor speed (rpm)
* 1500	45	M01	IEC50	0.09	2800
1800	30	M02	IEC50	0.09	2800
2000	20	M03	IEC50	0.06	1400
2500	10	M04	IEC50	0.06	1400
2500	5	M05	IEC50	0.06	1400

With single-phase motors type M (see motor choice guideline in paragraph ACCESSORIES) performances are 20% lower than the three-phase motor.

- * When speed is more than 40 mm/s and/or strokes longer than 350mm, check STROKE SETUP section; BRAKEMOTOR IS RECOMMENDED
- ** For 12 Vdc power supply currents are doubled and loads are 20% lower.

BEFORE OPERATING ACTUATOR MAKE SURE YOU READ AND UNDERSTOOD BASIC OPERATIONAL INSTRUCTIONS SHOWN ON USERMANUALS, AVAILABLE FROM WEBSITE.

THIS DOCUMENT DISPLAYS MOST TYPICAL STANDARD FEATURES AND SETUPS: CONTACT OUR OFFICES FOR MORE.

ACTUATOR SHALL NOT COME TO **MECHANICAL STROKE-END**, TO **AVOID FAILURES**.

CONSIDER MECVEL'S LIMITSWITCHES (MODEL ALI2-F or ALI2-FCM) OR PUT THEM ON MACHINE/FRAME.



MecVel reserves the right to change products information and/or features without notice; all data contained in this catalogue are purely indicative and not binding for the company.

ALI2 Version without limitswitches

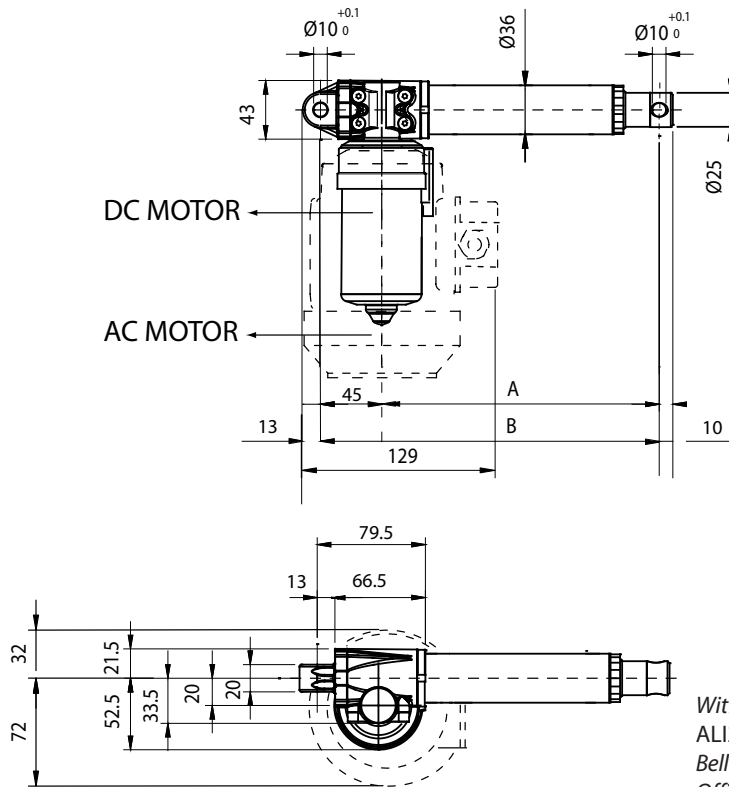

DIMENSION	Stroke < to 320 mm	Stroke > to 320 mm
A	70 + stroke	80 + stroke
B	115 + stroke	125 + stroke
C with brake	220.5	
C without brake	182.5	

With safety nut "G" = + 30 mm

ALI2-VRS = + 40 mm (safety nut unavailable)

Bellows + 20mm (for FCM limitswitches contact our Offices)

ALI2-F Version with limitswitches

Limitswitches Box
(2 x changeover type)

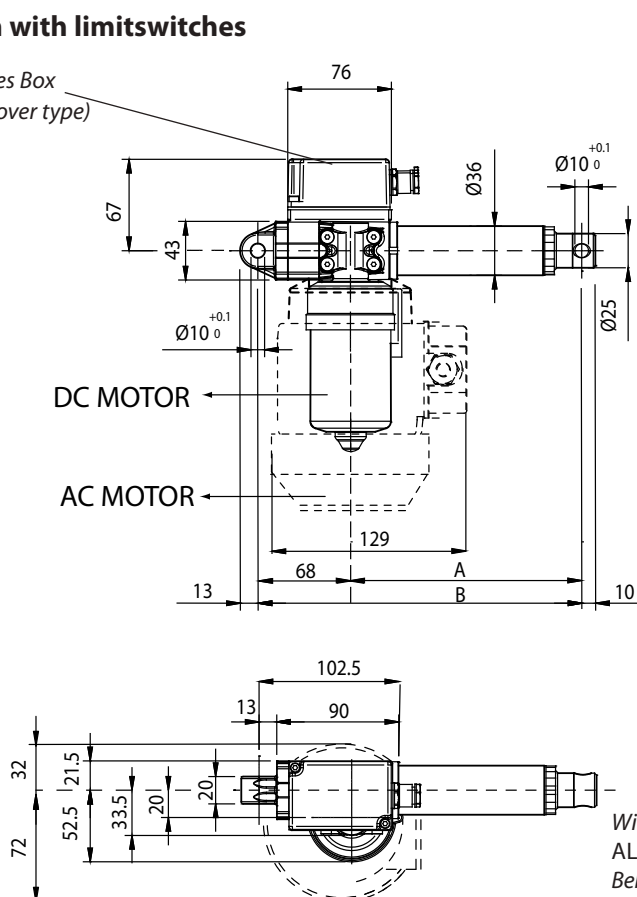

DIMENSION	Stroke < to 320 mm	Stroke > to 320 mm
A	70 + stroke	80 + stroke
B	138 + stroke	148 + stroke
C with brake	220.5	
C without brake	182.5	

With safety nut "G" = + 30 mm

ALI2-F-VRS = + 40 mm (safety nut unavailable)

Bellows + 20mm (for FCM limitswitches contact our Offices)

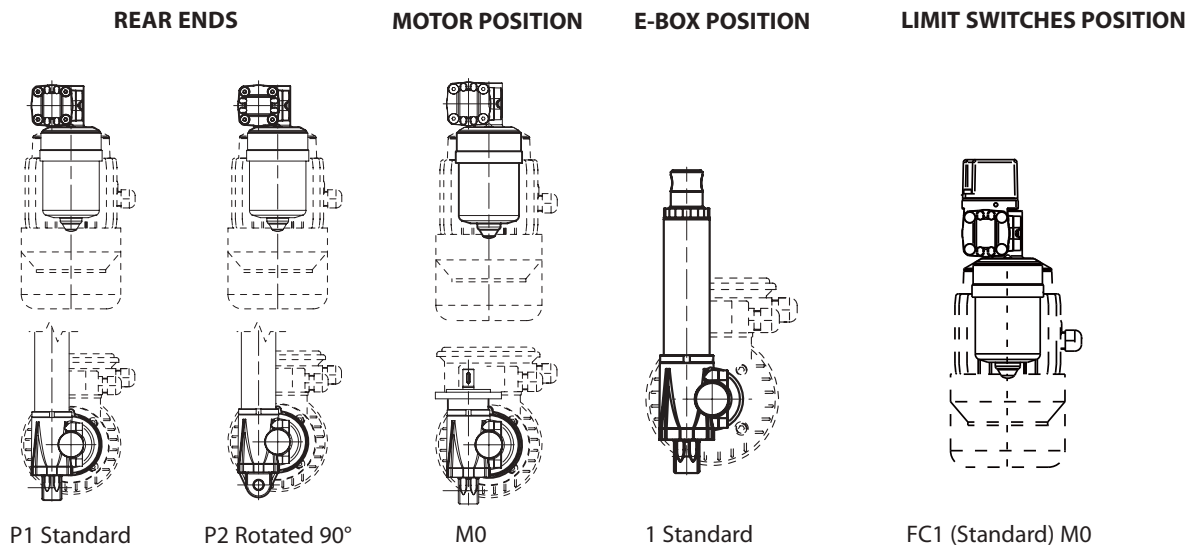

STROKE SETUP: Useful tips for handling stroke and avoid run-on-block collision.

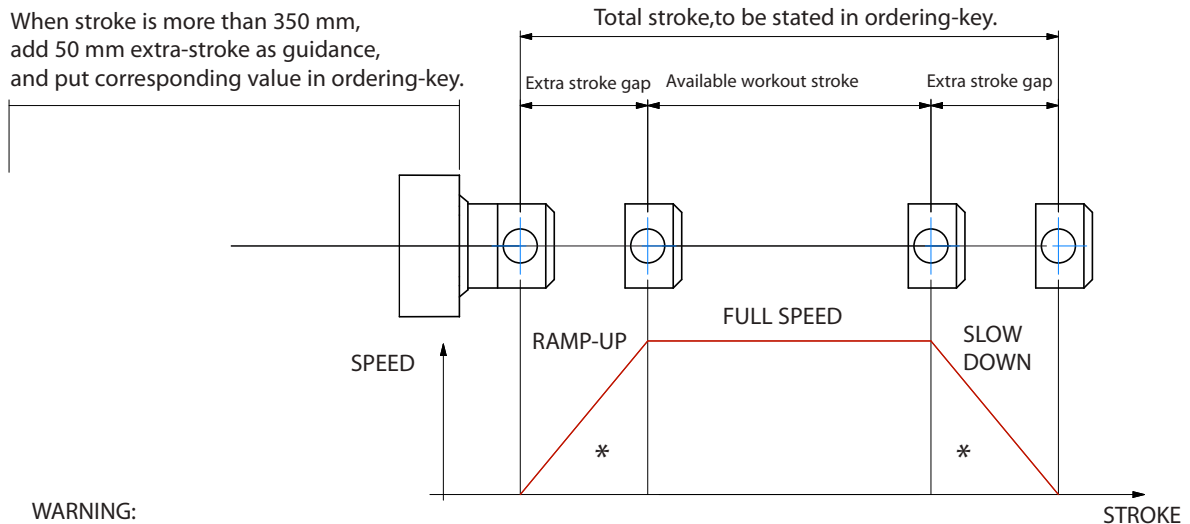

BUCKLING: When stroke is longer than 500mm, BUCKLING can be a risk: please check mounting with our offices and/or see user-manuals.

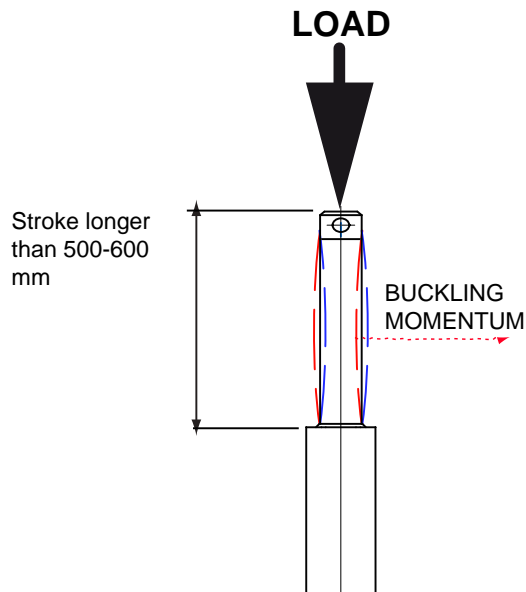

IMPORTANT:
Long strokes, even if load is low, can generate significant buckling momentums, as sketch slows.
This happens when actuator is in its all-opened position: that's the reason why we recommend 100 mm extra-stroke.
Push tube will have this 100 mm-portion always inside the over tube, improving guidance against buckling.
For more information on this, contact our office.

ALI2 / 0250 / M01 / CA-400/50-T-50-4-0,09 / AB / M0 / 1 / E01 / 2FC1 / P0T01A / FC1 / P1 / A1

MODEL: _____
 ALI2 / ALI2-F / ALI2-VRS / ALI2-F-VRS / ALI2-FCM

STROKE: _____
 es. 250 mm = 0250
 min 50; with 50 as incremental

VERSION: (pag.21) _____
 M08 / M09 / M10 / M11 / M12 / M13 / M14 (version C.C.)
 M01 / M02 / M03 / M04 / M05 / M06 / M07 / M08 M09 / M10 (version C.A)

MOTOR: (Pag. ACCESSORIES) _____
 Advise only if with motor:
A.C.: version, voltage, type, size, n°pole, power
D.C.: version, voltage, size, Rpm

AC MOTOR OPTIONS: (Pag. ACCESSORIES) _____
 No motor or DC motor: leave all following parameters blank
 Protection Degree: IP65, for selfbrake motor IP54 standard
 Brake type: for brakemotors only: ES. FECA
 Options: Advise if needed (ES. AB 2'shaft)

MOTOR POSITION: _____
M0 None: Leave blank

E-BOX POSITION: _____
1

ENCODER: (Pag. ACCESSORIES) _____
 None: Leave blank

LIMIT SWITCHES: (Pag. ACCESSORIES) _____
2FC1 None: Leave blank

POTENTIOMETER: (Pag. ACCESSORIES) _____
POT01A (1Kohm) **POT10A** (10Kohm) None: / Leave blank

LIMIT SWITCHES POSITION: _____
FC1 None: Leave blank

REAR END: _____
P1 = Eyelet (standard) **P2** = Eyelet (90°)

FRONT END: _____
A1 = Eyelet (Std pag.22) **A3** = Yoke + Clip
A4 = Rod end **A7** = M10 male

NOTE: COMPLETE THE ORDERING KEY ADDING THE OPTIONS YOU CAN FIND IN THE "ACCESSORIES AND OPTIONS" SECTION

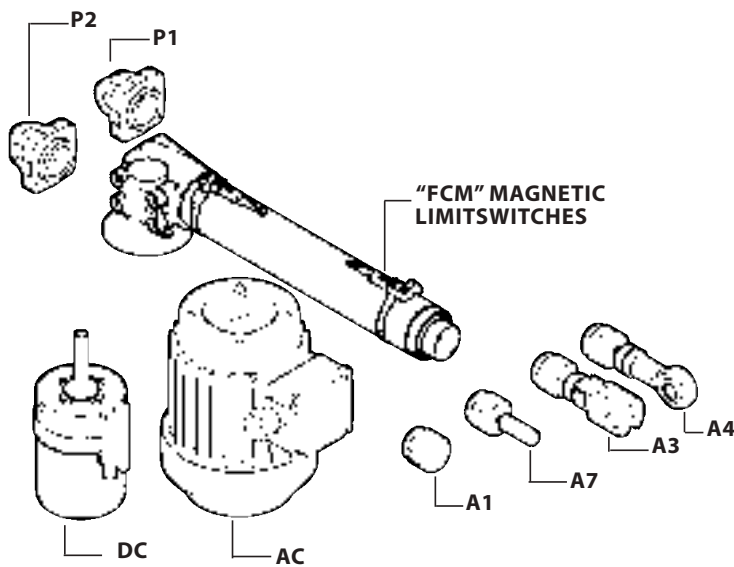

Note: "B" dimension changes according to model

ALI2 = See pictures
 ALI2 stroke > 320 mm = + 10 mm
 ALI2-FCM = + 34 mm
 ALI2-FCM stroke > 320 mm = +44
 ALI2-F = + 23 mm
 ALI2-F stroke > 320 mm = + 33 mm

With safety nut "G" = + 30 mm
 ALI2-VRS = + 40 mm
 ALI2-F-VRS = + 63 mm
 Bellows + 20mm

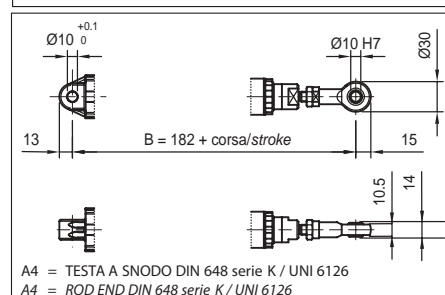
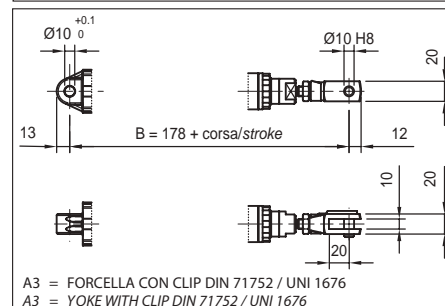
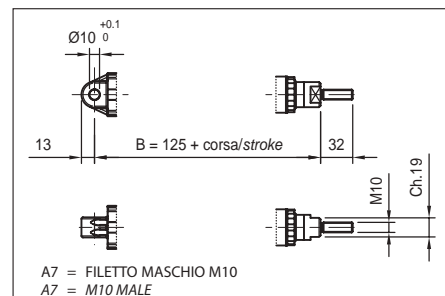

ALI2-P Model CE

- Permanent magnet motor CE
 - Double worm gearbox
 - Acme lead screw or ballscrew (VRS)**
 - Chrome plated steel push rod
 - Permanent grease lubrication
 - IP 65, tested according to rule CEI EN 60529
 - Working temperature range -10°C +60°C
 - Intermittent duty S3 30% (5 min) a 30°C*
 - Limit switches, potentiometer and encoder on request
- (*) For any special duty please contact our technical dept.
 (**) Contact our technical dept.

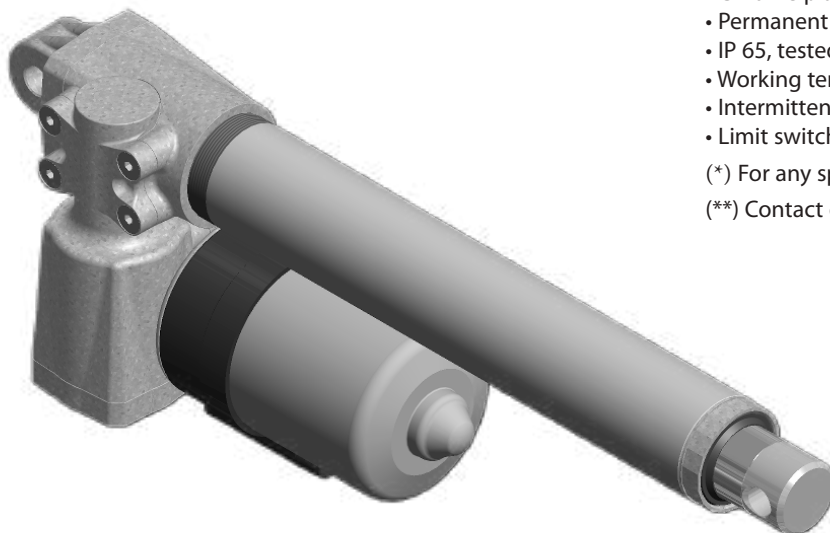

ALI2-P (Vdc)						
Fmax (N)	Speed (mm/s)	Version	Motor size	Motor Power (KW)	Motor speed (rpm)	Max Current for F max(A) 24Vdc
2400	30	M01	61.5	-	4000	8,2
2600	20	M02	61.5	-	4000	7,8
3000	15	M03	61.5	-	4000	6
4200	10	M04	61.5	-	4000	7
4200	7	M05	61.5	-	4000	5,8
4200	5	M06	61.5	-	4000	4,8
4200	2.5	M07	61.5	-	4000	3,2
4200	1.2	M08	61.5	-	4000	2,6
4200	0.6	M09	61.5	-	4000	1,8

When stroke is longer than 350mm, check STROKE SETUP section.

**For 12 Vdc power supply currents are doubled and loads are 20% lower.

BEFORE OPERATING ACTUATOR MAKE SURE YOU READ AND UNDERSTOOD BASIC OPERATIONAL INSTRUCTIONS SHOWN ON USERMANUALS, AVAILABLE FROM WEBSITE.

THIS DOCUMENT DISPLAYS MOST TYPICAL STANDARD FEATURES AND SETUPS: CONTACT OUR OFFICES FOR MORE.

ACTUATOR SHALL NOT COME TO **MECHANICAL STROKE-END**, TO AVOID **FAILURES**.

CONSIDER MECVEL's LIMITSWITCHES (MODEL ALI2-F or ALI2-FCM) OR PUT THEM ON MACHINE/FRAME.



MecVel reserves the right to change products information and/or features without notice; all data contained in this catalogue are purely indicative and not binding for the company.

AL12-P Version without limitswitches

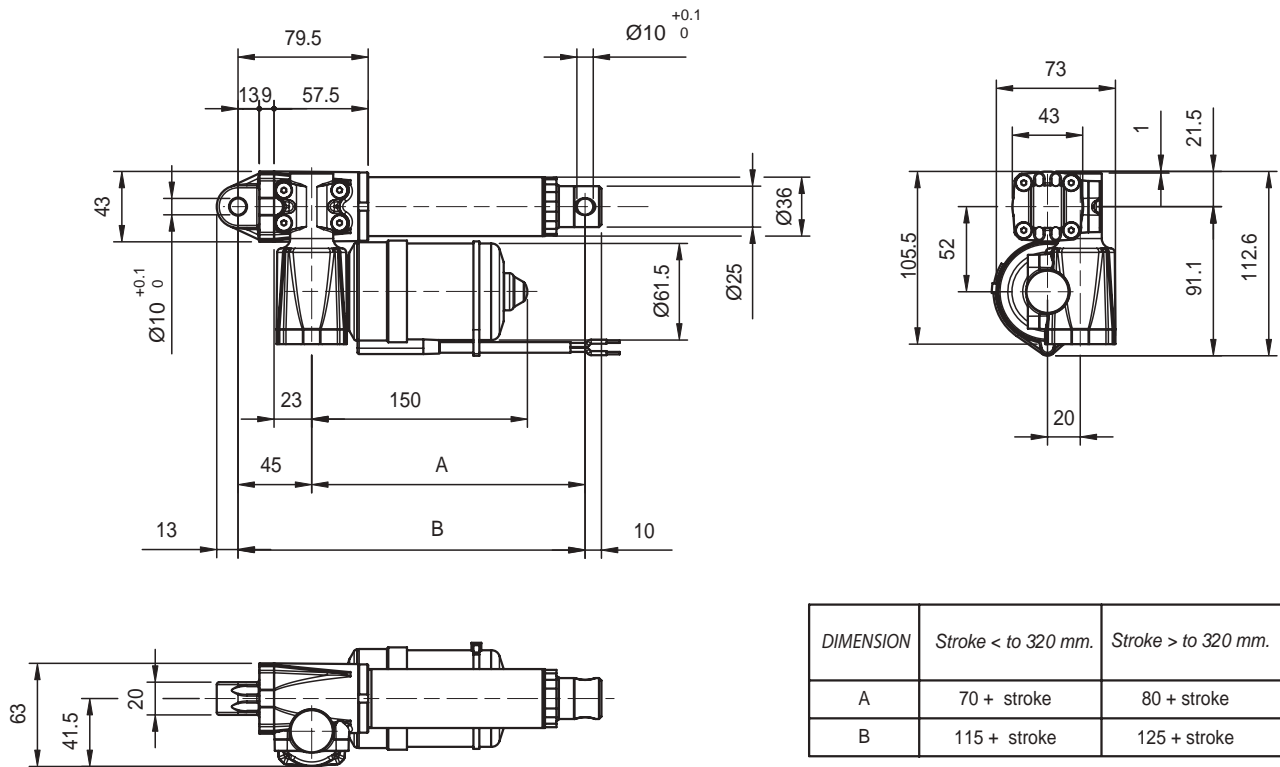

AL12-P-F Version with limitswitches

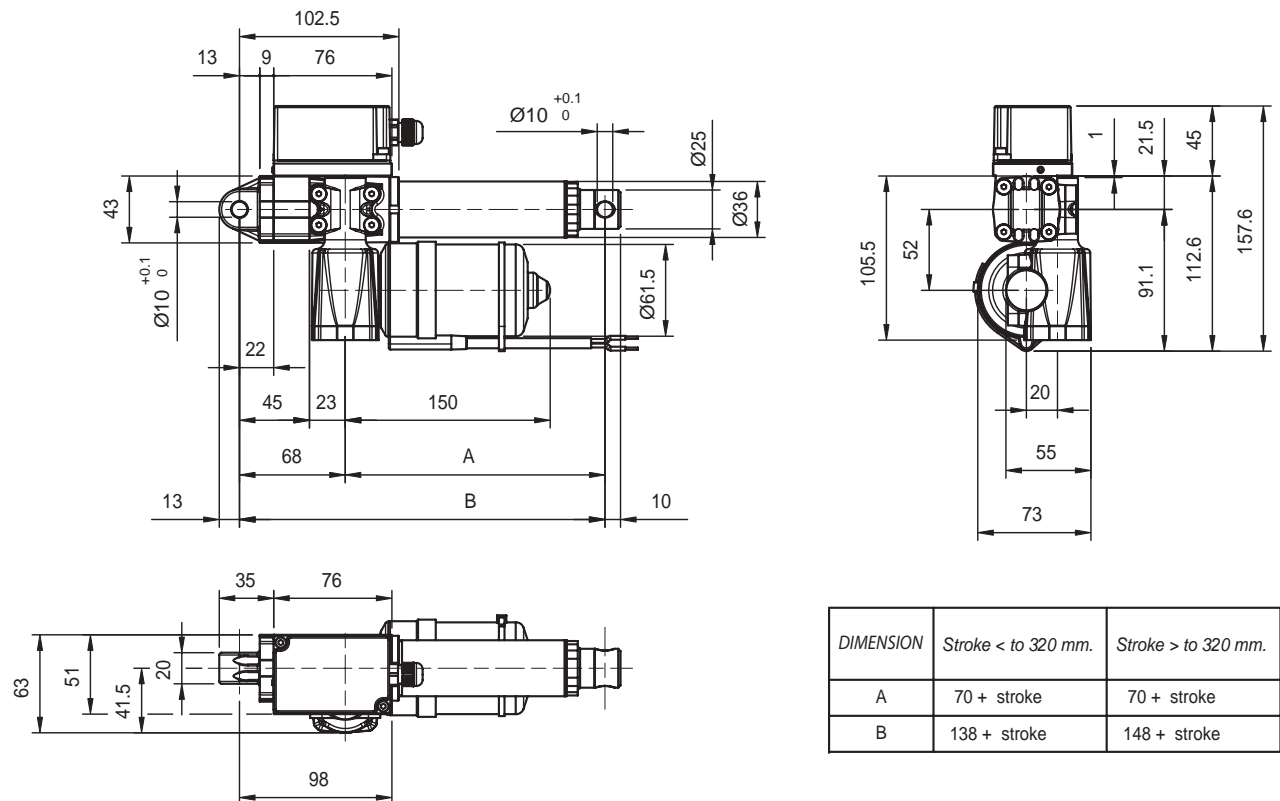

REAR ENDS

MOTOR POSITION

MOTOR AND LIMIT SWITCHES POSITION

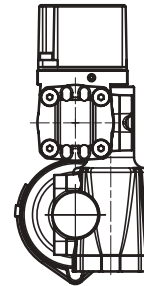
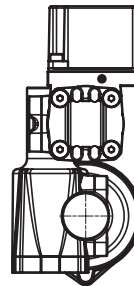
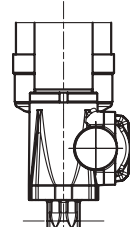
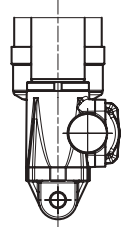
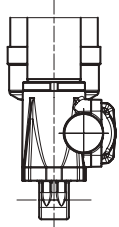
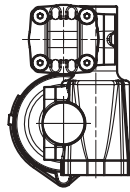
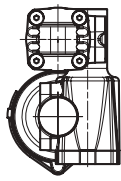
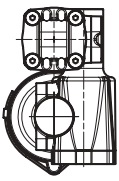

P1 Standard

P2 Rotated 90°

M0

M1 FC1

M0 FC1

STROKE SETUP: Useful tips for handling stroke and avoid run-on-block collision.

When stroke is more than 350 mm, add 50 mm extra-stroke as guidance, and put corresponding value in ordering-key.

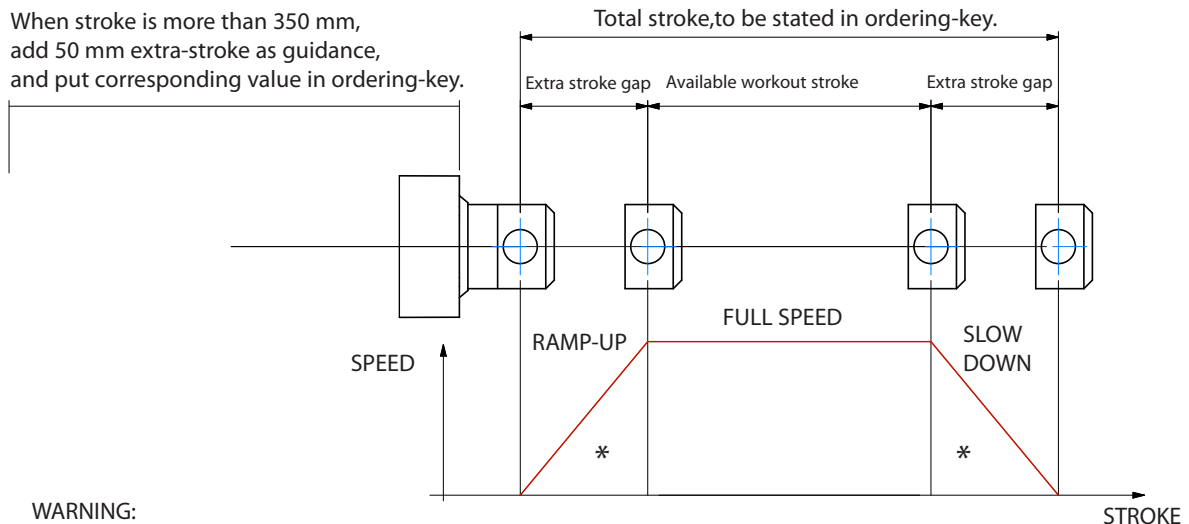

WARNING:

SPEED-TIMING ALONG STROKELENGTH:

ramps are extremely important with high speed !!! Inverter or PWM drive recommended!

* The more speed raises the more extra stroke has to raise too.

BUCKLING: With strokes longer than 500mm, BUCKLING can be a risk: please check mounting with our offices and/or see usermanuals.

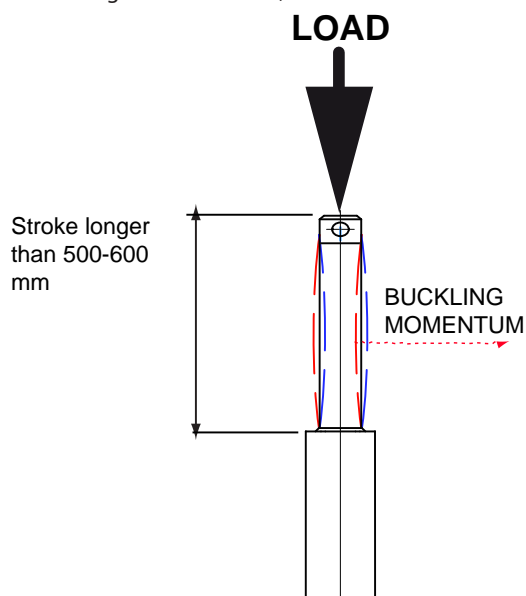

IMPORTANT:

Long strokes, even if load is low, can generate significant buckling momentums, as sketch slows.

This happens when actuator is in its all-opened position: that's the reason why we recommend 100 mm extra-stroke.

Pushtube will have this 100 mm-portion always inside the overtube, improving guidance against buckling.

For more information on this, contact our office.

ORDERING KEY

ALI2P / 0250 / M01 / 61,5-24 / 2FC1 / P0T01A / E01 / M0FC1 / P1 / A1

MODEL:

ALI2-P ALI2-PF
ALI2-P-FCM

STROKE:

es. 250 mm = 0250

VERSION: (pag.25)

M01 / M02 / M03 / M04 / M05 / M06 / M07 / M08 / M09

M00 = Not standard speed

MOTOR: (available)

12 = 12 Vcc

24 = 24 Vcc

LIMIT SWITCHES: (Pag. ACCESORIES)

None: Leave blank

POTENTIOMETER: (Pag. ACCESORIES)

POT01A (1Kohm) POT10A (10Kohm) None: / Leave blank

ENCODER: (Pag. ACCESORIES)

None: Leave blank

LIMIT SWITCHES POSITION: (Pag. ACCESORIES)

M0FC1 M1FC1 None: Leave blank

REAR END:

P1 = Eyelet (standard)

P2 = Eyelet (90°)

FRONT END:

A1 = Eyelet (Std pag.28)

A4 = Rod end

A3 = Yoke + Clip

A7 = M10 male

NOTE: COMPLETE THE ORDERING KEY ADDING THE OPTIONS YOU CAN FIND IN THE "ACCESSORIES AND OPTIONS" SECTION.

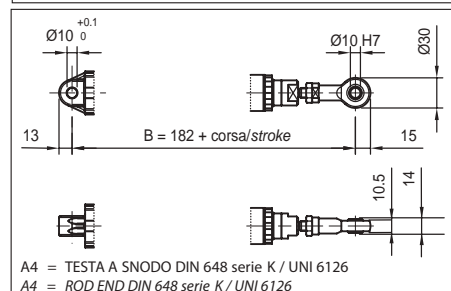
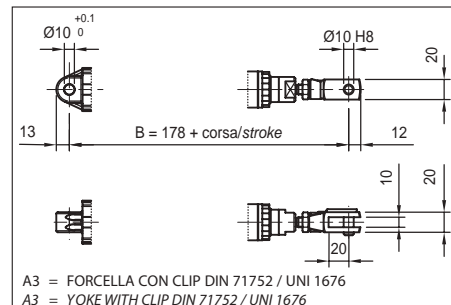
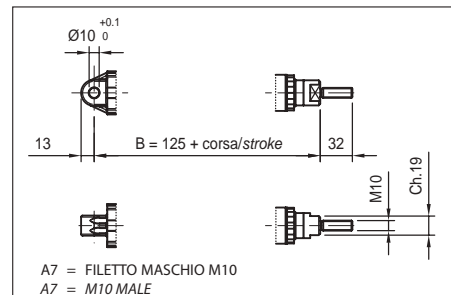
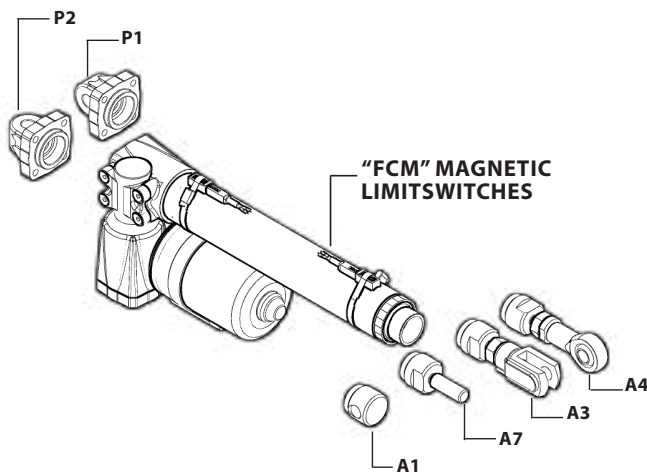

Note: "B" dimension changes according to model

ALI2-P= See pictures

With safety nut "G" = + 30 mm

ALI2-P stroke > 320 mm = + 10 mm

Bellows = + 20mm

ALI2-PF = + 23 mm

ALI2-PF stroke > 320 mm = +33

ALI2-P-FCM = + 33 mm

ALI2-P-FCM stroke > 320 mm = +43 mm

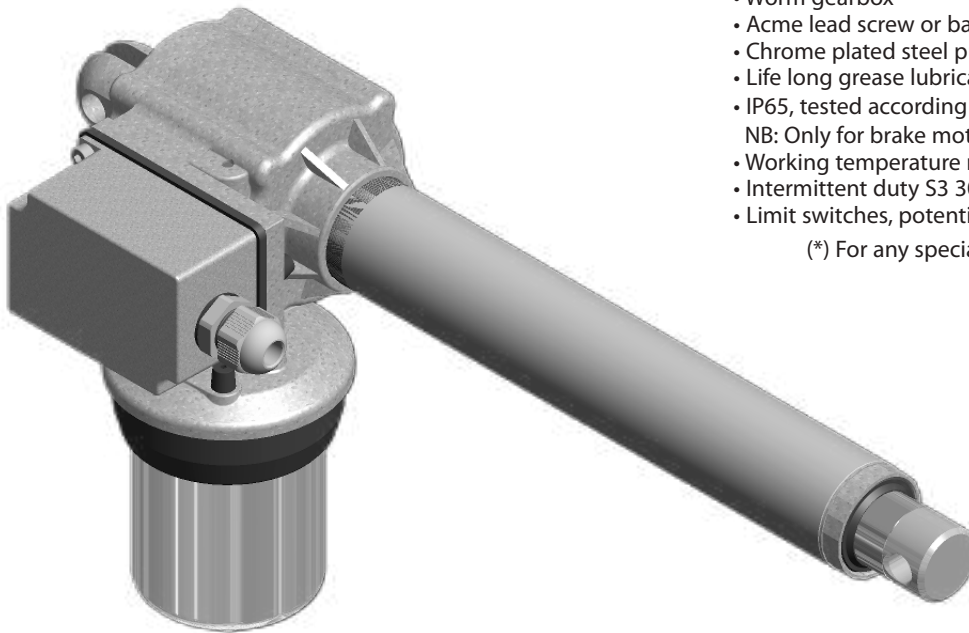

ALI3 Model C€

- Permanent magnet motor CE
 - Three phase or single phase motor CE
 - Worm gearbox
 - Acme lead screw or ballscrew (VRS)
 - Chrome plated steel push rod
 - Life long grease lubricated
 - IP65, tested according to rule CEI EN 60529
 - NB: Only for brake motors Standard IP54, IP65 on request
 - Working temperature range -10°C +60°C
 - Intermittent duty S3 30% (5 min) a +30°C*
 - Limit switches, potentiometer and encoder on request
- (*) For any special duty please contact our technical dept.

ALI3 (Vac 3-phase)					
Fmax (N)	Speed (mm/s)	Version	Motor size	Motor power (KW)	Motor speed (rpm)
2600	20	M01	IEC50	0.09	2800
2800	14	M02	IEC50	0.09	2800
4800	7	M03	IEC50	0.09	2800
5000	5	M04	IEC50	0.09	2800
5000	2.5	M05	IEC50	0.06	2800

ALI3 (Vdc)						
Fmax (N)	Speed (mm/s)	Version	Motor size	Motor power (KW)	Motor speed (rpm)	Max Current for Fmax(A) 24Vdc
3600	35	M01	61.5	-	5000	13
3600	25	M02	61.5	-	5000	9
6000	12	M03	61.5	-	5000	10
6000	9	M04	61.5	-	5000	7,6
6000	5	M05	61.5	-	5000	5,8

ALI3 VRS (ballscrew) (Vac 3-phase)					
Fmax (N)	Speed (mm/s)	Version	Motor size	Motor power (KW)	Motor speed (rpm)
5000	9	M01	IEC50	0.09	2800
5000	3,5	M02	IEC50	0.09	2800

With single-phase motors type M (see motor choice guideline in paragraph ACCESSORIES) performances are 20% lower than the three-phase motor.

When stroke is longer than 350mm, check STROKE SETUP section; BRAKEMOTOR IS RECOMMENDED

**For 12 Vdc power supply currents are doubled and loads are 20% lower.

BEFORE OPERATING ACTUATOR MAKE SURE YOU READ AND UNDERSTOOD BASIC OPERATIONAL INSTRUCTIONS SHOWN ON USERMANUALS, AVAILABLE FROM WEBSITE.

THIS DOCUMENT DISPLAYS MOST TYPICAL STANDARD FEATURES AND SETUPS: CONTACT OUR OFFICES FOR MORE.

ACTUATOR SHALL NOT COME TO **MECHANICAL STROKE-END**, TO AVOID **FAILURES**.

CONSIDER MECVEL's LIMITSWITCHES (MODEL ALI3-F or ALI3-FCM) OR PUT THEM ON MACHINE/FRAME.



MecVel reserves the right to change products information and/or features without notice; all data contained in this catalogue are purely indicative and not binding for the company.

AL13 Version without limitswitches

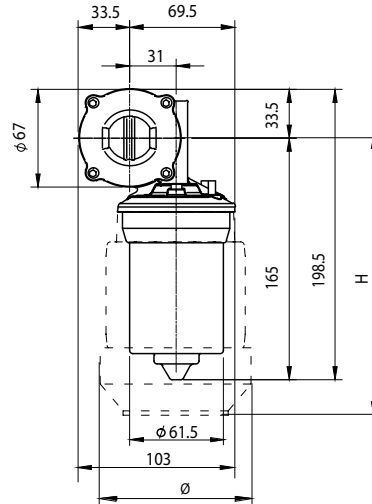
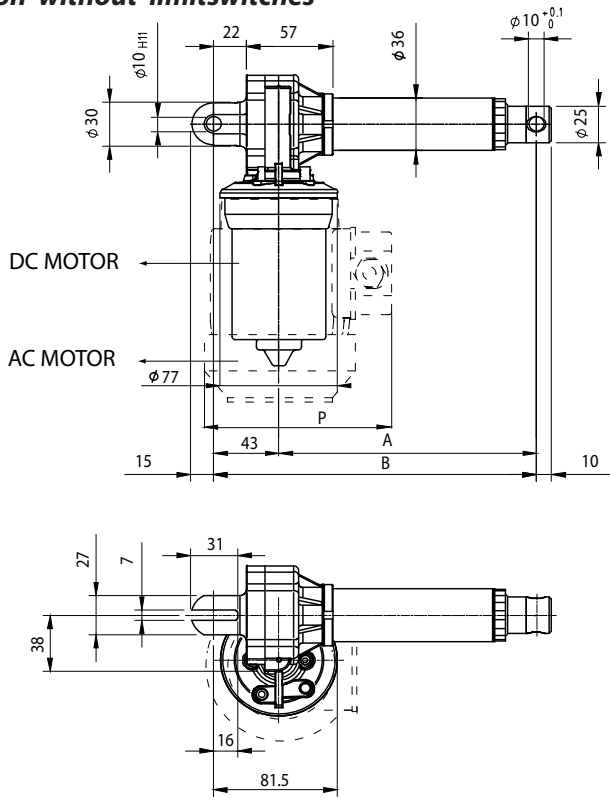

DIM.	Stroke < to 320 mm.	Stroke > to 320 mm.
A	69 + stroke	79 + stroke
B	112 + stroke	122 + stroke

A.C MOTORS DIMENSIONS				
SIZE	TYPE	H	Ø	P
50	Standard	188	110	105
	Brake Motors	226		
56	Standard	216	110	108
	Brake Motors	260		

With safety nut "G" = + 30 mm
 AL13-VRS = + 40 mm (safety nut unavailable)
 Bellows + 20mm (for FCM limitswitches contact our Offices)

AL13-F Version with limitswitches

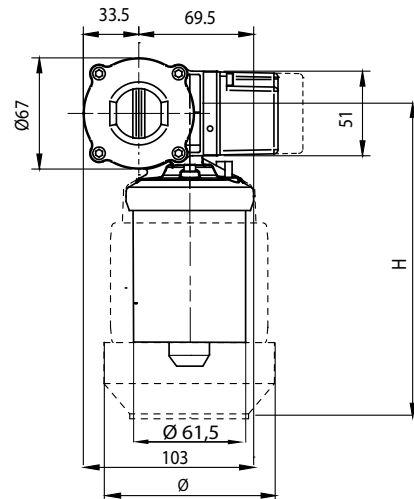
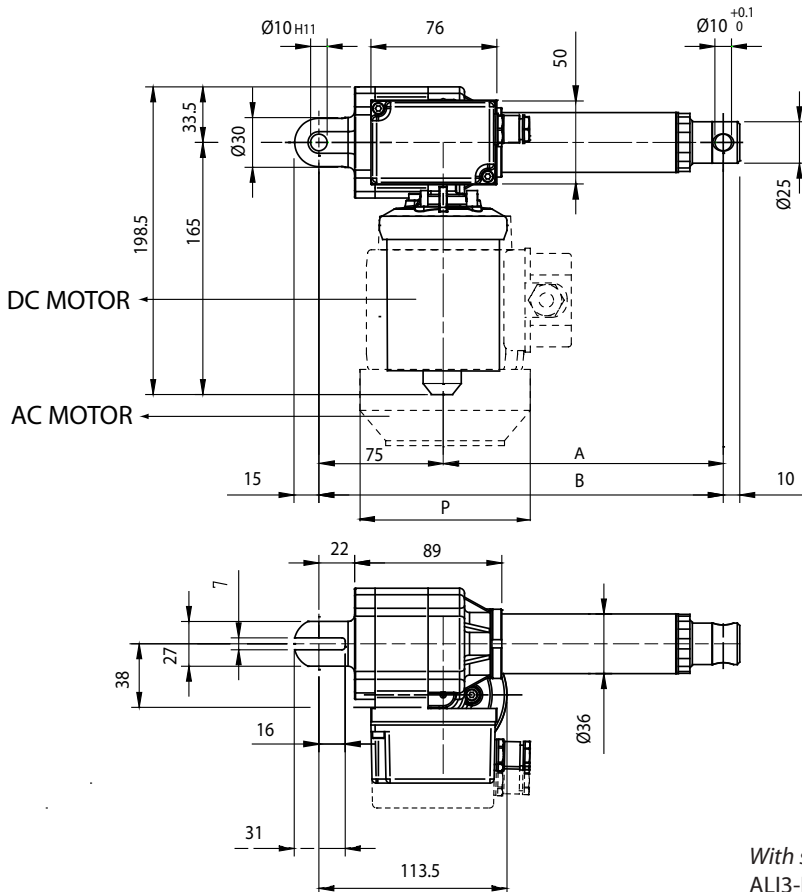

DIM.	Stroke < to 320 mm.	Stroke > to 320 mm.
A	69 + stroke	79 + stroke
B	144 + stroke	154 + stroke

A.C MOTORS DIMENSIONS				
SIZE	TYPE	H	Ø	P
50	Standard	188	110	105
	Brake Motors	226		
56	Standard	216	110	108
	Brake Motors	260		

With safety nut "G" = + 30 mm
 AL13-F-VRS = + 40 mm (safety nut unavailable)
 Bellows + 20mm (for FCM limitswitches contact our Offices)

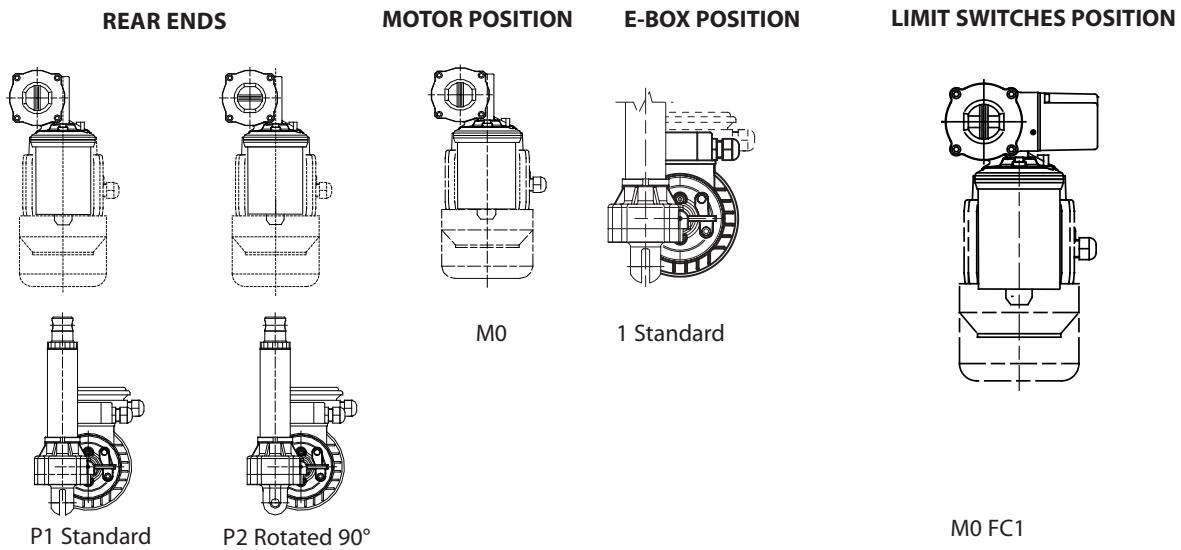

STROKE SETUP: Useful tips for handling stroke and avoid run-on-block collision.

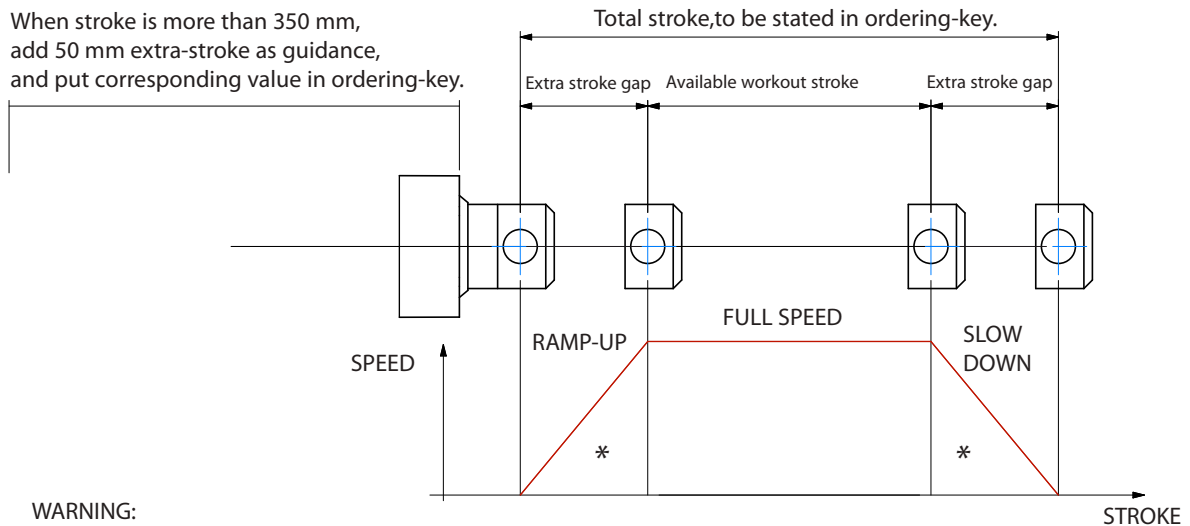

WARNING:
SPEED-TIMING ALONG STROKELENGTH:
 ramps are extremely important with high speed !!! Inverter or PWM drive recommended!
 * The more speed raises the more extra stroke has to raise too.

BUCKLING: With strokes longer than 500mm, BUCKLING can be a risk: please check mounting with our offices and/or see usermanuals.

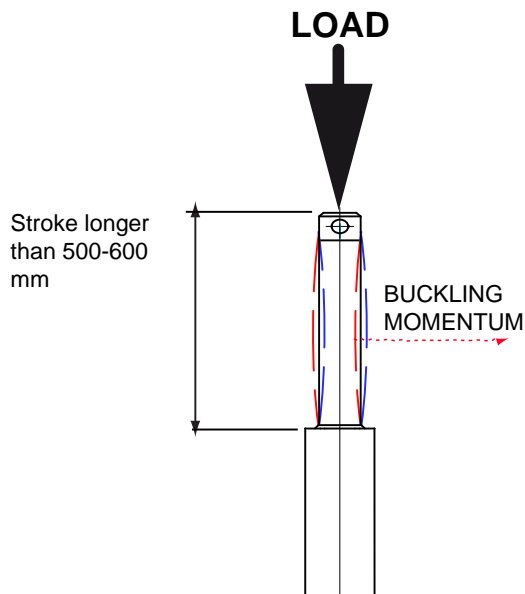

IMPORTANT:
 Long strokes, even if load is low, can generate significant buckling momentums, as sketch slows.
 This happens when actuator is in its all-opened position: that's the reason why we recommend 100 mm extra-stroke.
 Pushtube will have this 100 mm-portion always inside the overtube, improving guidance against buckling.
 For more information on this, contact our office.

ALI3 / 0250 / M01 / CA-400/50-T-56-4-0,09 / AB / M1 / 1 / E01 / 2FC1 / POT01A / FC1 / P1 / A1

MODEL: _____
 ALI3 / ALI3-F / ALI3-VRS / ALI3-F-VRS / ALI3-FCM

STROKE: _____
 es. 250 mm = 0250

VERSION: (Pag. 29) _____
 M01 / M02 / M03 / M04 / M05 (version D.C.)
 M01 / M02 / M03 / M04 / M05 (version A.C.)
 M00 = Not standard speed

MOTOR: (Pag. ACCESSORIES) _____
 Advise only if with motor:
A.C.: version, voltage, type, size, n°pole, power
D.C.: version, voltage, size, Rpm

AC MOTOR OPTIONS: (Pag. ACCESSORIES) _____
 Protection Degree: IP65, for selfbrake motor IP54 standard
 Brake type: for brakemotors only: ES. FECA
 Options: Advise if needed (ES. AB 2'shaft)

MOTOR POSITION: _____
M0 None: Leave blank

E-BOX POSITION: _____
1
 No Motor or DC Motor: Leave blank

ENCODER: (Pag. ACCESSORIES) _____
 None: Leave blank

LIMIT SWITCHES: (Pag. ACCESSORIES) _____
 None: Leave blank

POTENTIOMETER: (Pag. ACCESSORIES) _____
POT01A (1Kohm) **POT10A** (10Kohm) None: Leave blank

LIMIT SWITCHES POSITION: _____
FC1 None: Leave blank

REAR END: _____
P1 = Eyelet (standard) **P2** = Eyelet (90°)

FRONT END: _____
A1 = Eyelet (Std pag.30) **A4** = Rod end
A3 = Yoke + Clip **A7** = M10 male

NOTE: COMPLETE THE ORDERING KEY ADDING THE OPTIONS YOU CAN FIND IN THE "ACCESSORIES AND OPTIONS" SECTION

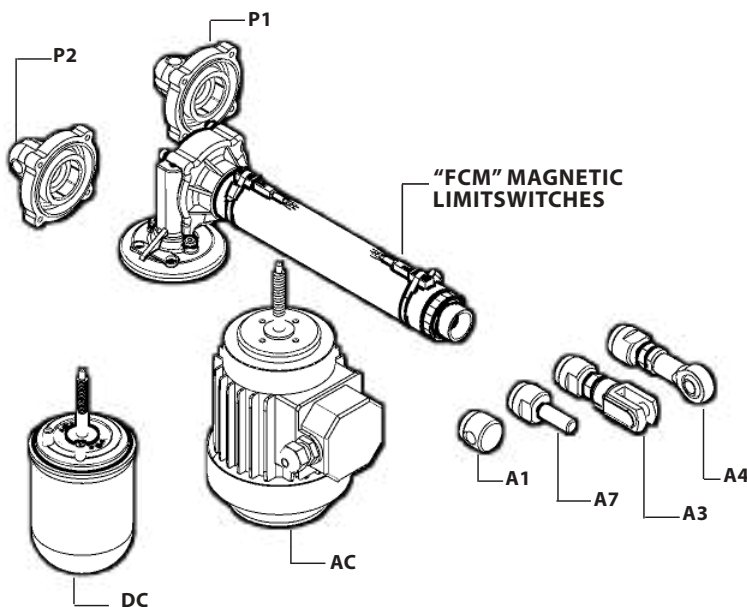

Note: "B" dimension changes according to model

- | | |
|----------------------------------|-------------------------------|
| ALI3 = See pictures | With safety nut "G" = + 30 mm |
| ALI3 stroke > 320 mm = + 10 mm | ALI3-VRS = + 40 mm |
| ALI3-FCM = + 34 mm | ALI3-F-VRS = + 63 mm |
| ALI3-FCM stroke > 320 mm = +44 | Bellows + 20mm |
| ALI3-F = + 23 mm | |
| ALI3-F stroke > 320 mm = + 33 mm | |

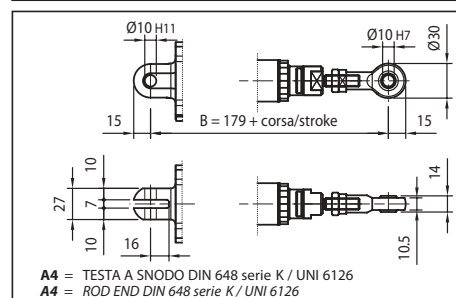
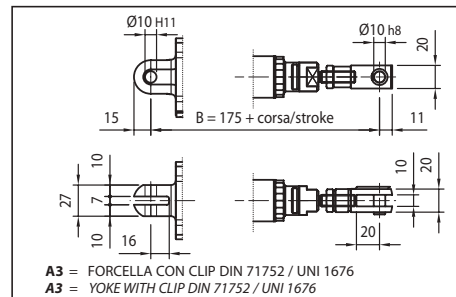
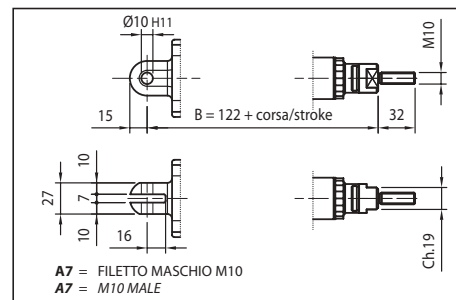

ALI3-P Model CE

- Permanent magnet motor CE
- Worm gearbox
- Acme lead screw or ballscrew (VRS)
- Chrome plated steel push rod
- Permanent grease lubrication
- IP65, tested according to rule CEI EN 60529
- Working temperature range -10°C +60°C
- Intermittent duty S3 30% (5 min) a +30°C*
- Limit switches, potentiometer and encoder on request

(*) For any special duty please contact our technical dept.

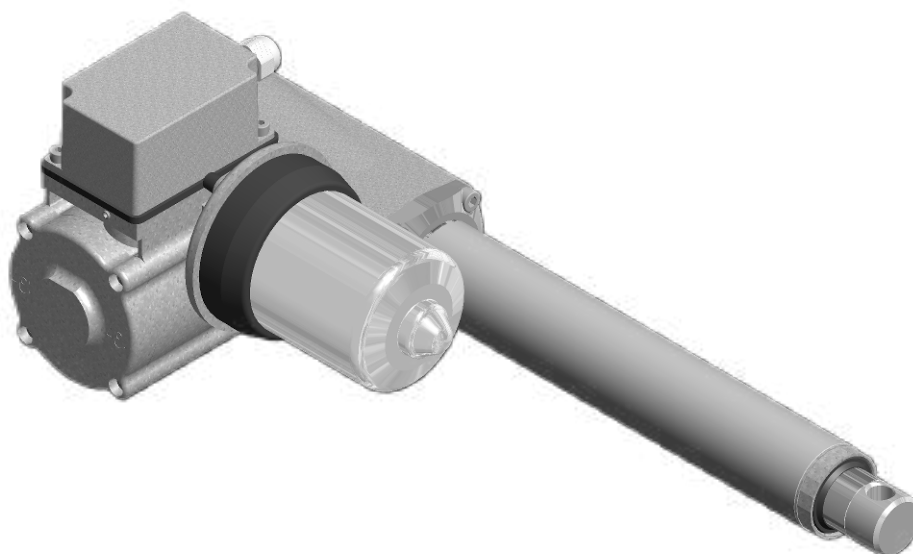

ALI3-P (Vdc)						
Fmax (N)	Speed (mm/s)	Version	Motor size	Motor power (KW)	Motor speed (rpm)	Max Current for Fmax(A) 24Vdc
3600	35	M01	61.5	-	5000	14
3600	25	M02	61.5	-	5000	10
6000	12	M03	61.5	-	5000	11
6000	9	M04	61.5	-	5000	8,8
6000	5	M05	61.5	-	5000	7,2

**

* With strokes longer than 350mm, check STROKE SETUP section.

** For 12 Vdc power supply currents are doubled and loads are 20% lower.

BEFORE OPERATING ACTUATOR MAKE SURE YOU READ AND UNDERSTOOD BASIC OPERATIONAL INSTRUCTIONS SHOWN ON USERMANUALS, AVAILABLE FROM WEBSITE.

THIS DOCUMENT DISPLAYS MOST TYPICAL STANDARD FEATURES AND SETUPS: CONTACT OUR OFFICES FOR MORE.

ACTUATOR SHALL NOT COME TO **MECHANICAL STROKE-END**, TO **AVOID FAILURES**.

CONSIDER MECVEL'S LIMITSWITCHES (MODEL ALI3-P-F or ALI3-P-FCM) OR PUT THEM ON MACHINE/FAME.



MecVel reserves the right to change products information and/or features without notice; all data contained in this catalogue are purely indicative and not binding for the company.

ALI3-P Version without limitswitches

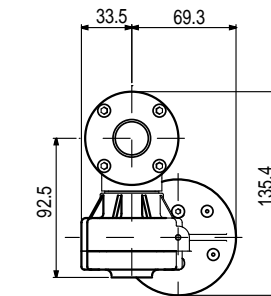
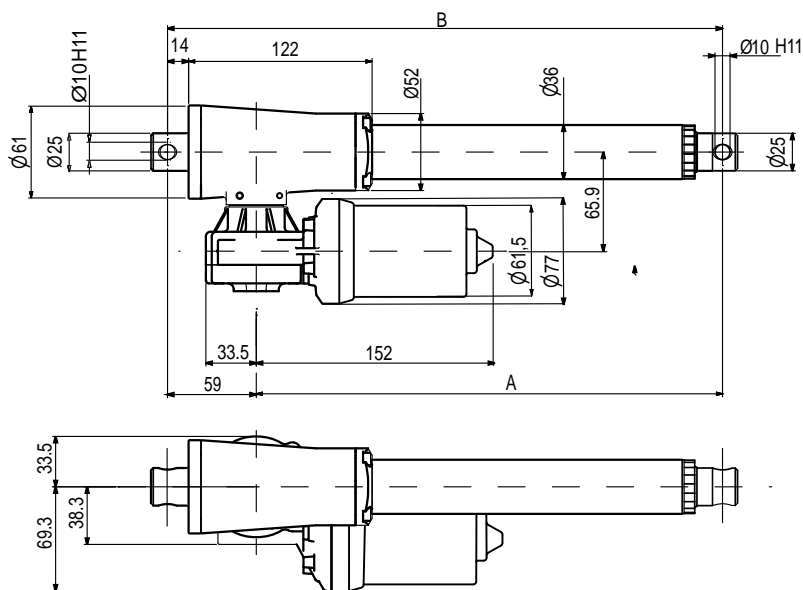

DIMENSION	Stroke < to 320 mm.	Stroke > to 320 mm.
A	110 + stroke	121 + stroke
B	169 + stroke	180 + stroke

ALI3-P-F Version with limitswitches

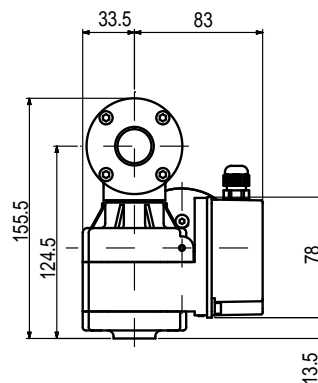
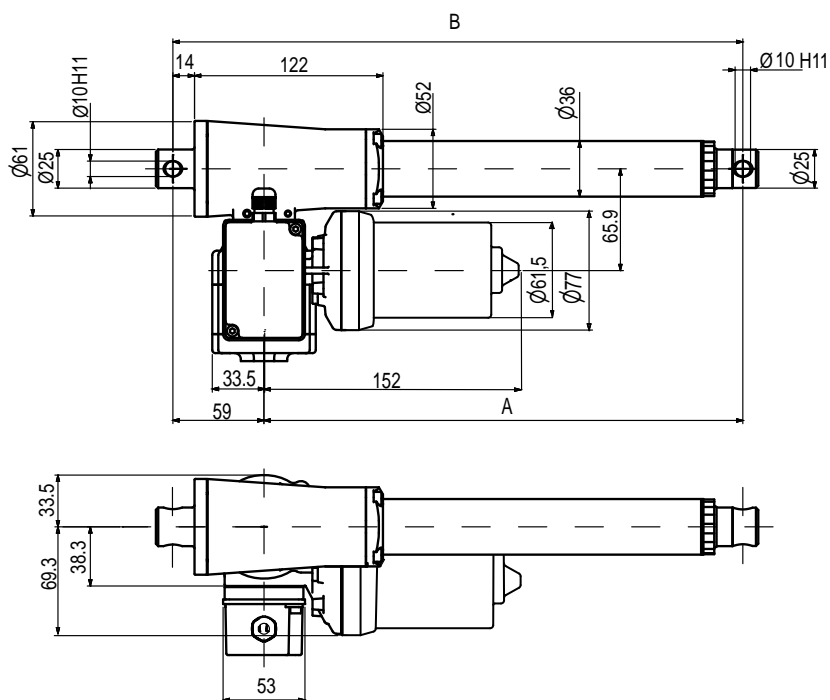

DIMENSION	Stroke < to 320 mm.	Stroke > to 320 mm.
A	110 + stroke	121 + stroke
B	169 + stroke	180 + stroke

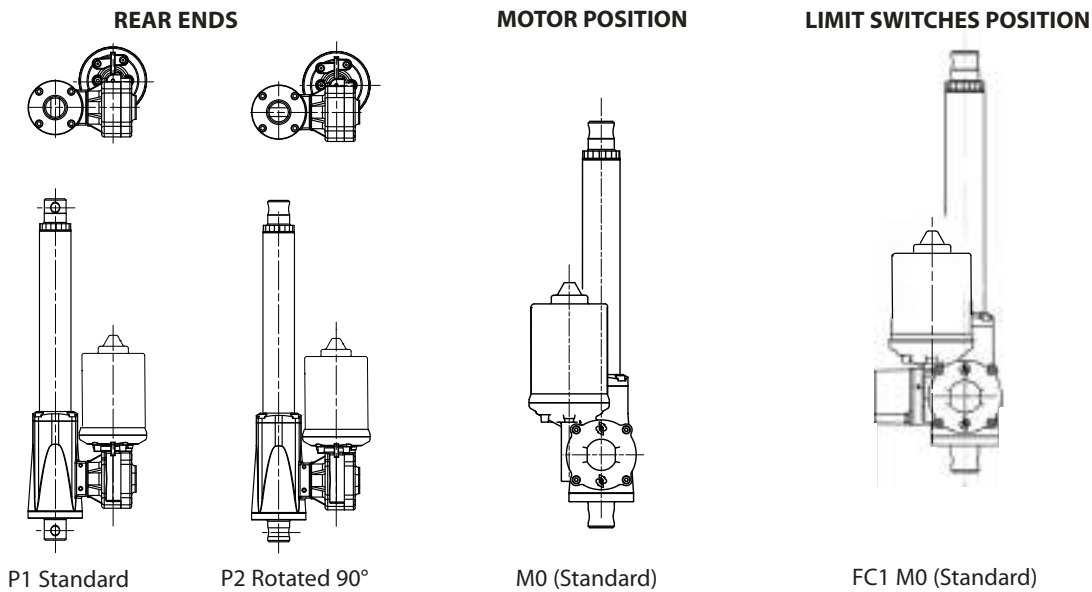

STROKE SETUP: Useful tips for handling stroke and avoid run-on-block collision.

When stroke is more than 350 mm, add 50 mm extra-stroke as guidance, and put corresponding value in ordering-key.

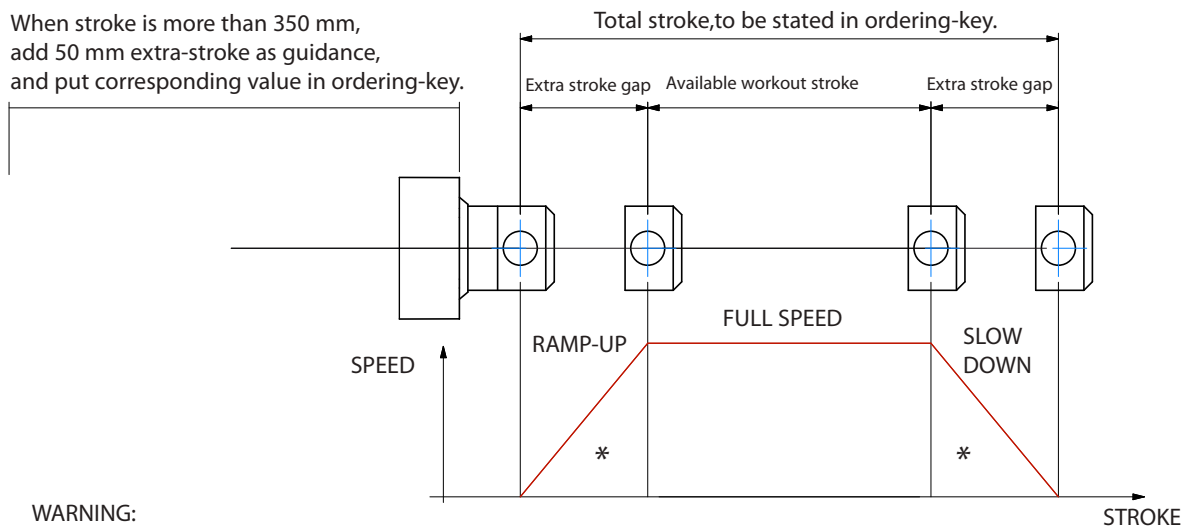

WARNING:
SPEED-TIMING ALONG STROKELENGTH:
 ramps are extremely important with high speed!!! Inverter or PWM drive recommended!
 * The more speed raises the more extra stroke has to raise too.

BUCKLING: With strokes longer than 500mm, BUCKLING can be a risk: please check mounting with our offices and/or see usermanuals.

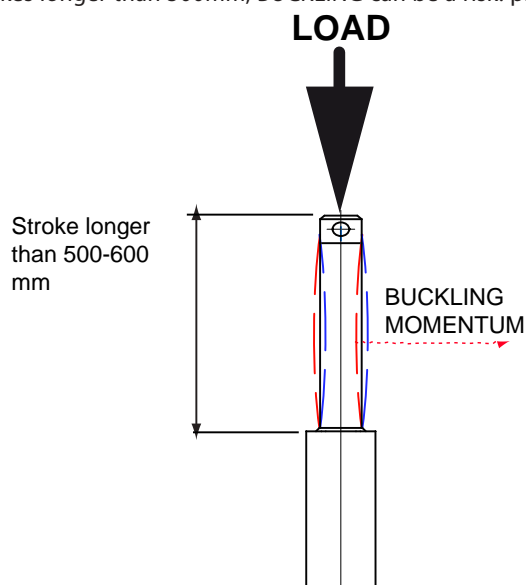

IMPORTANT:
 Long strokes, even if load is low, can generate significant buckling momentums, as sketch slows.
 This happens when actuator is in its all-opened position: that's the reason why we recommend 100 mm extra-stroke.
 Pushtube will have this 100 mm-portion always inside the overtube, improving guidance against buckling.
 For more information on this, contact our office.

ALI3-P-F / 0250 / M01 / CC-24-61,5-5000- / M1 / 1 / E01 / 2FC1 / POT01A / FC1 / P1 / A1

MODEL: _____
 ALI3-P / ALI3-P-F
 ALI3-P-FCM

STROKE: _____
 es. 250 mm = 0250

VERSION: (pag.33) _____
 M01 / M02 / M03 / M04 / M05/
 (version D.C.)
 M00 = Not standard speed

MOTOR: (Page ACCESSORIES) _____
12 = 12 Vdc
24 = 24 Vdc

MOTOR POSITION: _____
M0 None: Leave blank

E-BOX POSITION: _____
1

No Motor or DC Motor: Leave blank

ENCODER: (Page ACCESSORIES) _____
 None: Leave blank

LIMIT SWITCHES: (Page ACCESSORIES) _____
 None: Leave blank

POTENTIOMETER: _____
POT01A (1Kohm) **POT10A** (10Kohm) None: / Leave blank

LIMIT SWITCHES POSITION: _____
FC1 None: Leave blank

REAR END: _____
P1 = Eyelet (standard) **P2** = Eyelet (90°)

FRONT END: _____
A1 = Eyelet (Std pag.34) **A4** = Rod end
A3 = Yoke + Clip **A7** = M10 male

NOTE: COMPLETE THE ORDERING KEY ADDING THE OPTIONS YOU CAN FIND IN THE "ACCESSORIES AND OPTIONS" SECTION

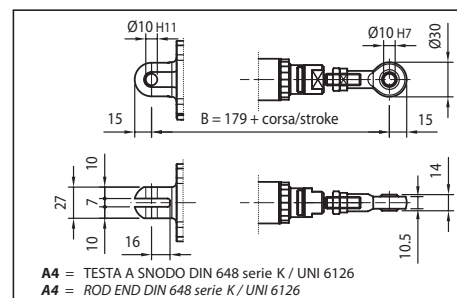
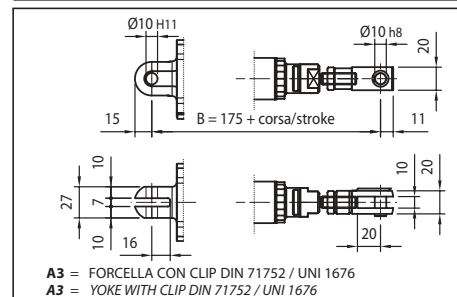
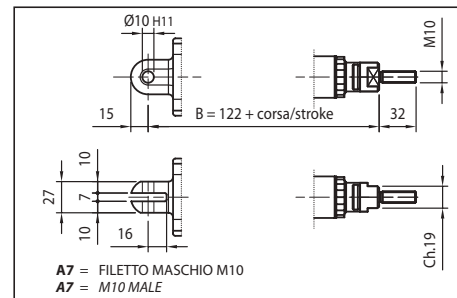
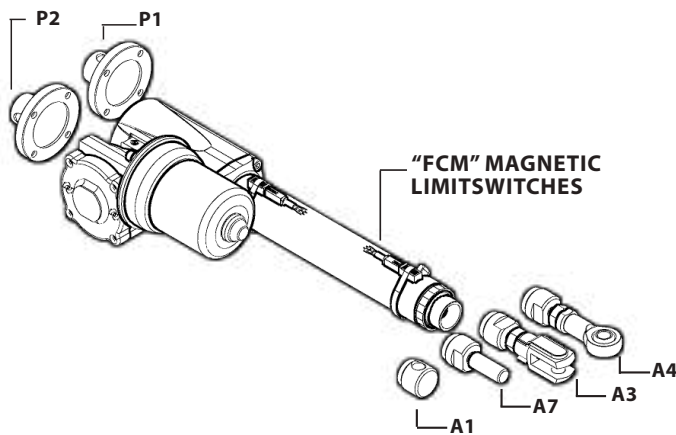

Note: "B" dimension changes according to model
 ALI3-P = see pictures
 ALI3-P stroke > 320 mm = + 10 mm (for all versions)
 ALI3-P-FCM = + 36 mm
 with safety nut "G" = + 30 mm
 Bellow + 20mm (no for versions FCM)

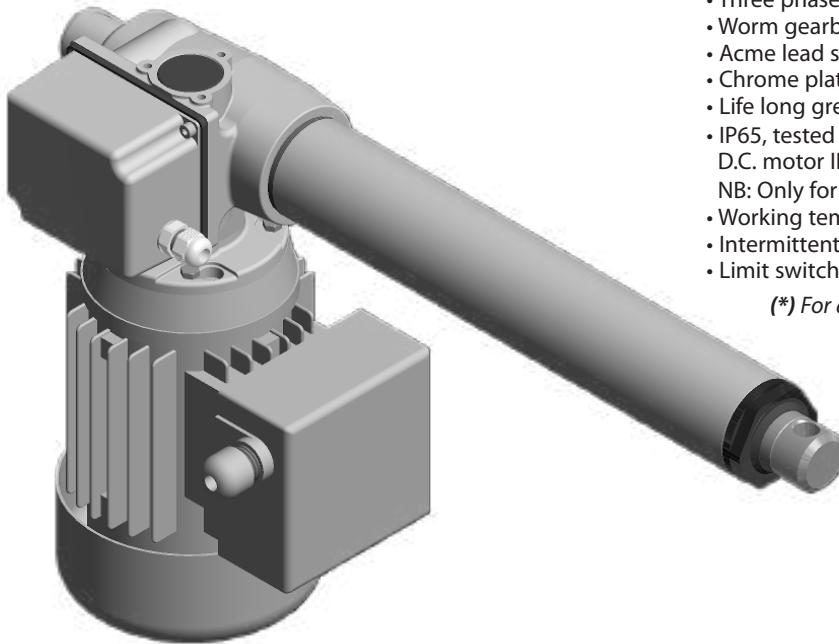

ALI4-Model CE

- Permanent magnet motor CE
- Three phase or single phase motor CE
- Worm gearbox
- Acme lead screw or ballscrew (VRS)
- Chrome plated steel push rod
- Life long grease lubricated
- IP65, tested according to rule CEI EN 60529
D.C. motor IP 54 standard - IP65 on request
- NB: Only for brake motors Standard IP54, IP65 on request
- Working temperature range -10°C +60°C
- Intermittent duty S3 30% (5 min) a +30°C*
- Limit switches, potentiometer and encoder on request

(*) For any special duty please contact our technical dept.

ALI4 (Vac 3-phase)

Fmax (N)	Speed (mm/s)	Version	Motor size	Motor power (KW)	Motor speed (rpm)
* 2100	93	M01	IEC71	0,55	2800
* 3900	47	M02	IEC71	0,55	2800
5300	23	M03	IEC63	0,37	1400
8600	9	M04	IEC63	0,22	1400
9400	6	M05	IEC63	0,18	1400
10000	3	M06	IEC63	0,13	1400
10000	2	M07	IEC56	0,09	1400

ALI4 (Vdc)

Fmax (N)	Speed (mm/s)	Version	Motor size	Motor power (KW)	Motor speed (rpm)	Max Current for Fmax(A) 24Vdc
* 600	100	M20	D.85	-	3000	10
* 1100	50	M21	D.85	-	3000	13
2800	20	M22	D.85	-	3000	13,5
4100	13	M23	D.85	-	3000	14
6800	7	M24	D.85	-	3000	12
10000	4	M25	D.85	-	3000	13

ALI4-VRS (ballscrew 16x5) (Vac)

Fmax (N)	Speed (mm/s)	Version	Motor size	Motor power (KW)	Motor speed (rpm)
* 2500	58	M08	IEC63	0,25	2800
3100	29	M09	IEC63	0,18	1400
3400	23	M10	IEC56	0,14	2800
5000	15	M11	IEC56	0,14	2800
6000	7	M12	IEC56	0,09	1400
7500	4	M13	IEC56	0,09	1400

ALI4 - VRS (ballscrew 16x5) 24 Vdc

Fmax (N)	Speed (mm/s)	Version	Motor size	Motor power (KW)	Motor speed (rpm)	Max Current for Fmax(A) 24Vdc
* 2400	63	M26	D.85	-	3000	14
3400	25	M27	D.85	-	3000	12
3900	16	M28	D.85	-	3000	10
6800	8	M29	D.85	-	3000	9
7500	5	M30	D.85	-	3000	9

With single-phase motors type M (see motor choice guideline in paragraph ACCESSORIES) performances are 20% lower than the three-phase motor.

* When speed is more than 40 mm/s and/or strokes longer than 350mm, check STROKE SETUP section; BRAKEMOTOR IS RECOMMENDED

** For 12 Vdc power supply currents are doubled and loads are 20% lower.

BEFORE OPERATING ACTUATOR MAKE SURE YOU READ AND UNDERSTOOD BASIC OPERATIONAL INSTRUCTIONS SHOWN ON USERMANUALS, AVAILABLE FROM WEBSITE.

THIS DOCUMENT DISPLAYS MOST TYPICAL STANDARD FEATURES AND SETUPS: CONTACT OUR OFFICES FOR MORE.

ACTUATOR SHALL NOT COME TO **MECHANICAL STROKE-END**, TO AVOID **FAILURES**.

CONSIDER MECVEL's LIMITSWITCHES (MODEL ALI4-F or ALI4-FCM) OR PUT THEM ON MACHINE/FRAME.



MecVel reserves the right to change products information and/or features without notice; all data contained in this catalogue are purely indicative and not binding for the company.

ALI4 Version without limitswitches

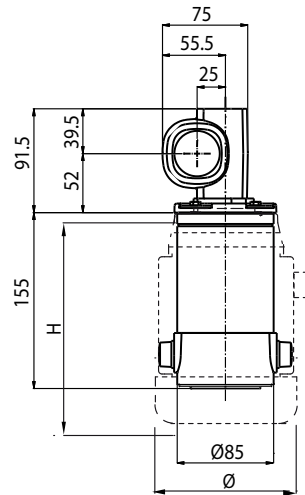
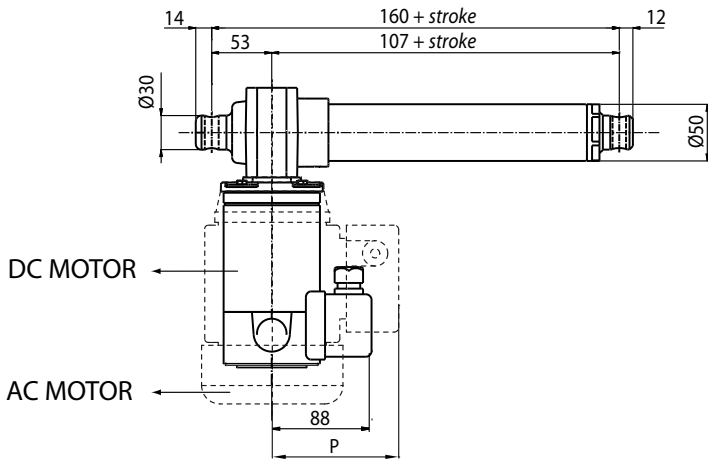

A.C. MOTORS DIMENSIONS				
GR. / SIZE	TYPE	H	Ø	P
56	Standard	168	116	108
	Brake motors	200		
63	Standard	190	129	110
	Brake motors	235		
71	Standard	220	146	121
	Brake motors	267		

With safety nut "G" = + 30 mm
 ALI4-VRS = + 25 mm (safety nut unavailable)
 Bellows + 20mm (for FCM limitswitches contact our Offices)

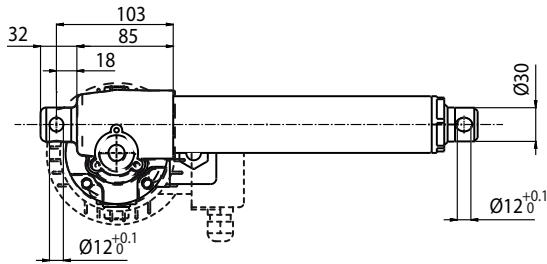

ALI4-F Version with limitswitches

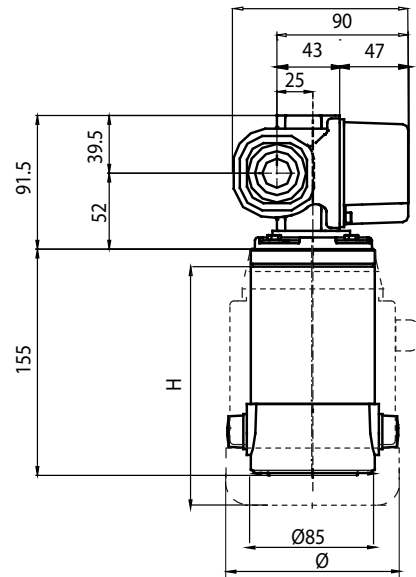
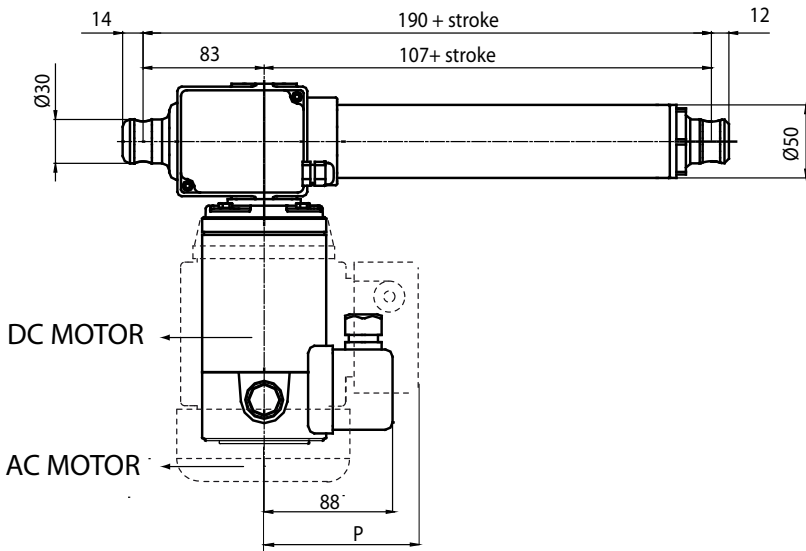

A.C. MOTORS DIMENSIONS				
SIZE	TYPE	H	Ø	P
56	Standard	168	116	108
	Brake motors	200		
63	Standard	190	129	110
	Brake motors	235		
71	Standard	220	146	121
	Brake motors	267		

With safety nut "G" = + 30 mm
 ALI4-VRS = + 25 mm (safety nut unavailable)
 Bellows + 20mm (for FCM limitswitches contact our Offices)

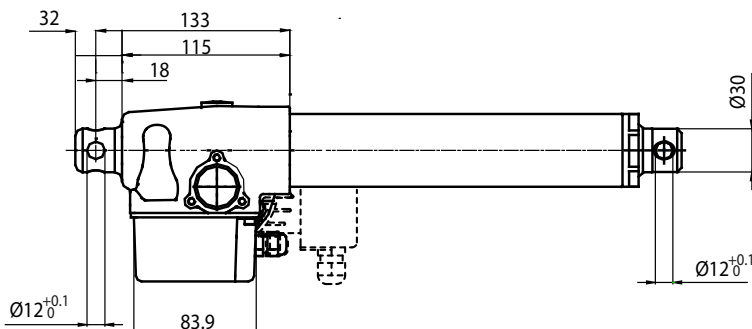

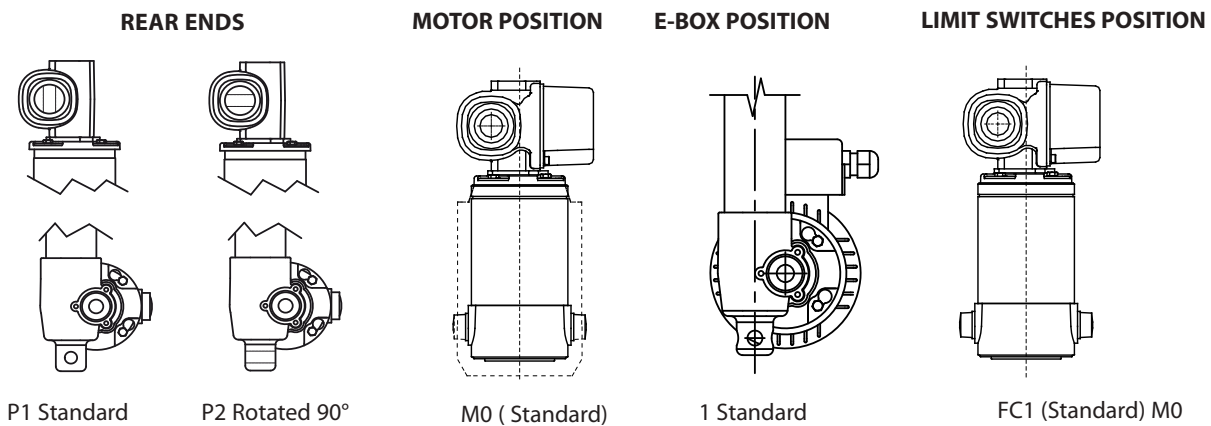

STROKE SETUP: Useful tips for handling stroke and avoid run-on-block collision.

When stroke is more than 350 mm, add 50 mm extra-stroke as guidance, and put corresponding value in ordering-key.

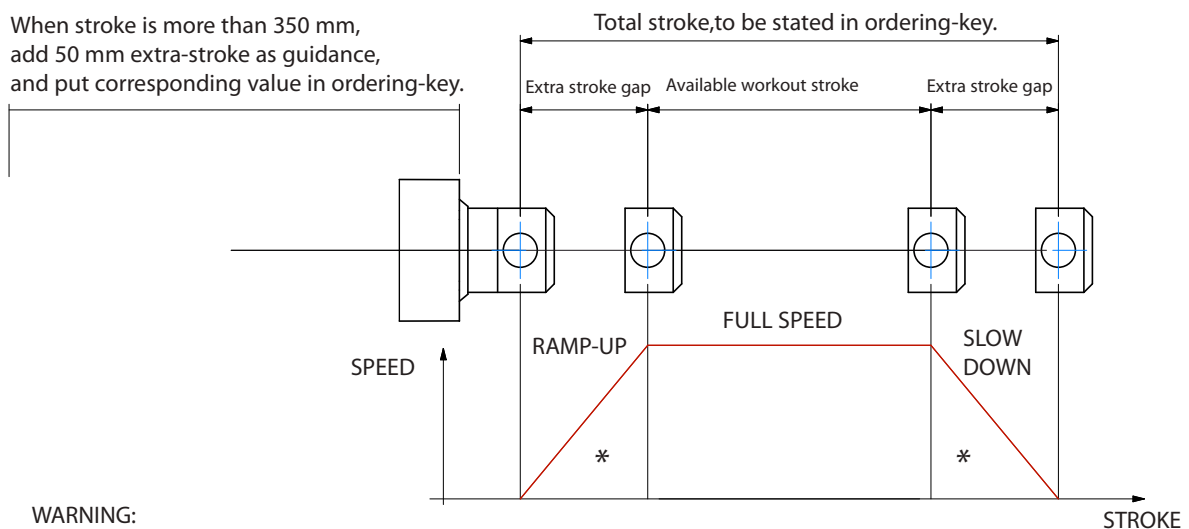

WARNING:
SPEED-TIMING ALONG STROKELENGTH:
 ramps are extremely important when speed is > 40mm/s !!! Inverter or PWM drive recommended!
 * The more speed raises the more extra stroke has to raise too.

BUCKLING: With strokes longer than 500mm, BUCKLING can be a risk: please check mounting with our offices and/or see user manuals.

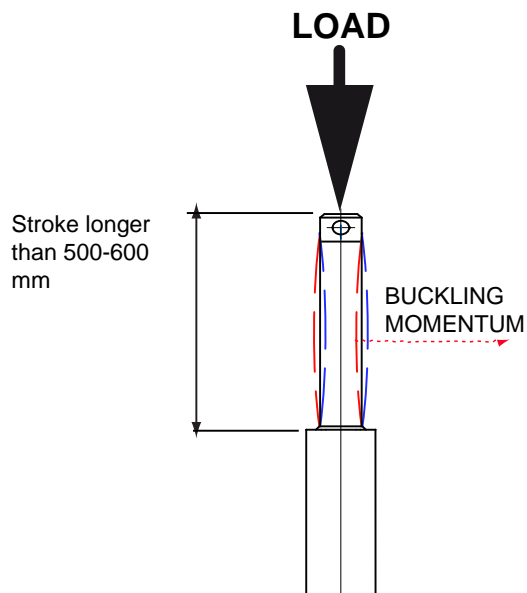

IMPORTANT:
 Long strokes, even if load is low, can generate significant buckling momentums, as sketch slows.
 This happens when actuator is in its all-opened position: that's the reason why we recommend 100 mm extra-stroke.
 Pushtube will have this 100 mm-portion always inside the overtube, improving guidance against buckling.
 For more information on this, contact our office.

ALI4 / 0250 / M01 / CA-400/50-T-56-4-0,09 / AB / FC1 / M0 / 1 / E01 / 2FC2 / POT01A / P1 / A1

MODEL: _____
 ALI4 / ALI4-F / ALI4-FCM / ALI4-FCI
 ALI4-VRS / ALI4-VRS-F / ALI4-VRS-FCM
 ALI4-VRS-FCI

STROKE: _____
 es. 250 mm = 0250

VERSION: (Pag. 37) _____
 Advise: choose among
 M00 Not standard speed
 Flanged Version = Rpm
 Advise reduction ratio and screw pitch

MOTOR: _____
 Advise only if with motor:
A.C.: version, voltage, type, size, n°pole, power
D.C.: version, voltage, size, Rpm
 With motorflange only put 0
 With special motorflange put: PD

AC MOTOR OPTIONS: (Pag. ACCESSORIES) _____
 Motorflange: for motorflange version only advise size - i.e. for IEC56 B14 put 56B14
 No motor or DC motor: leave all following parameters blank
 Protection Degree: IP65, for selfbrake motor IP54 standard
 Brake type: for brakemotors only: ES, FECA
 Options: Advise if needed (ES, AB 2'shaft)

LIMIT SWITCHES POSITION: _____
FC1 None: Leave blank

MOTOR POSITION: _____
M0 None: Leave blank

E-BOX POSITION: _____
1 No Motor: Leave blank

ENCODER: (Pag. ACCESSORIES) _____
 None: Leave blank

LIMIT SWITCHES: (Pag. ACCESSORIES) _____
 None: Leave blank

POTENTIOMETER: (Pag. ACCESSORIES) _____
POT01A (1Kohm) **POT10A** (10Kohm) None: Leave blank

REAR END: _____
P1 = Eyelet (standard) **P2** = Eyelet (90°)

FRONT END: _____
A1 = Eyelet (Std pag.38) **A3** = Yoke + Clip
A4 = Rod end **A7** = M12 male

NOTE: COMPLETE THE ORDERING KEY ADDING THE OPTIONS YOU CAN FIND IN THE "ACCESSORIES AND OPTIONS" SECTION.

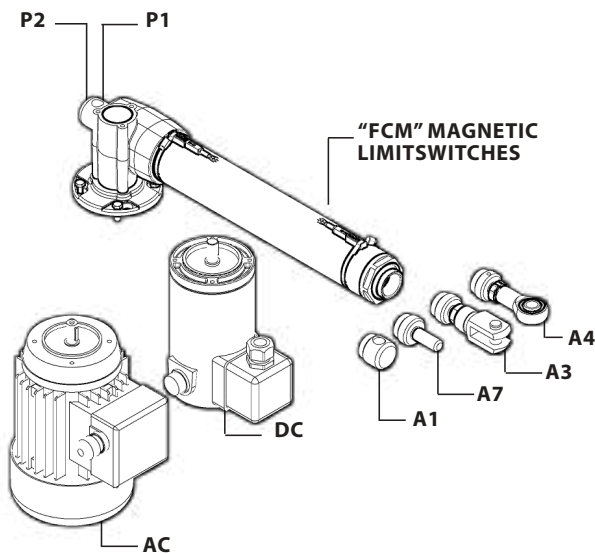

Note: "B" dimension variations depending on model

ALI4 = see pictures	ALI4-F = + 30 mm	ALI4-FCM = + 42,5 mm	ALI4-FCI = + 42,5 mm
	with safety nut "G" = + 30 mm	(i.e. ALI4-F "G" option = +30)	
ALI4-VRS (versione 16x5) = + 25 mm		ALI4-VRS-F (versione 16x5) = + 55 mm	
ALI4-VRS-FCM (versione 16x5) = + 53 mm		ALI4-VRS-FCI (versione 16x5) = + 53 mm	
L = + 15 mm			
Bellows = + 15 mm (excluding FCM and FCI version, for versions FCM and FCI contact MecVel)			

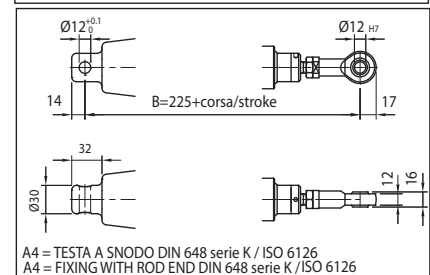
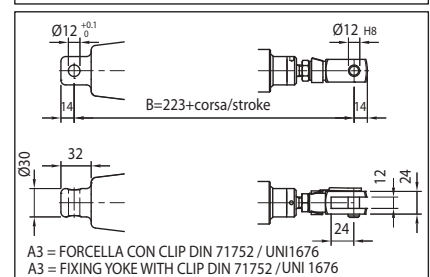
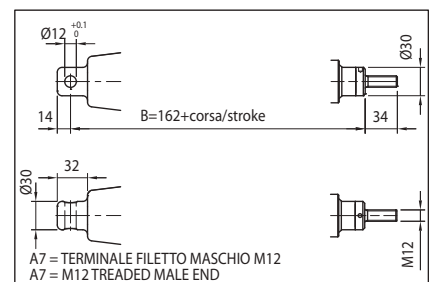

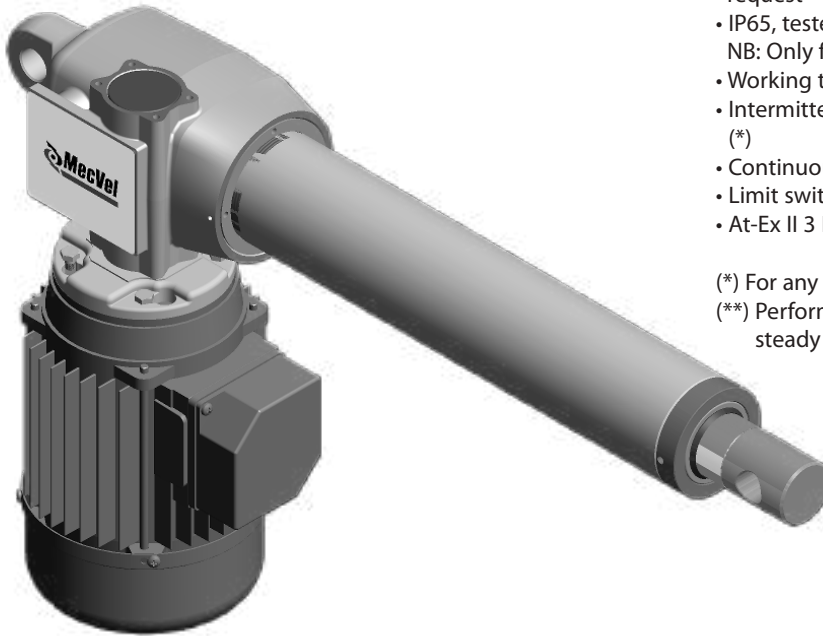

ALI5-Model C€

- Three phase or single phase motor CE
- Worm gearbox (ALI5)
- Acme lead screw or ballscrew (VRS)
- Chrome plated steel push road
- Grease (standard) or oil (VRS continuous duty S1) lubricated on request
- IP65, tested according to rule CEI EN 60529
NB: Only for brake motors Standard IP54, IP65 on request
- Working temperature range -10°C +60°C
- Intermittent duty S3 30% (5min) a +30°C acme lead screw version (*)
- Continuous duty S1 +30°C ballscrew version on request (**)
- Limit switch, potentiometer, encoder on request
- At-Ex II 3 D T4 version (A.C.motor) on request

(*) For any special duty, please contact our technical department

(**) Performance are related to ball screw, lifetime of 2000 hours with steady load and without shocks or vibrations

ALI 5 VRS (Vac 3-phase ballscrew)					
Fmax (N)	Speed (mm/s)	Version	Motor size	Motor power (KW)	Motor speed (rpm)
* 4800	93	M45	IEC71	0.55	2800
* 6000	47	M46	IEC71	0.37	2800
7500	23	M47	IEC71	0.37	2800
9500	12	M48	IEC71	0.25	1400
12000	6	M49	IEC71	0.25	1400

ALI5 (Vac 3-phase Acme lead screw)					
Fmax (N)	Speed (mm/s)	Version	Motor size	Motor power (KW)	Motor speed (rpm)
* 4300	93	M01	IEC80	1,1	2800
* 7200	47	M02	IEC80	1,1	2800
11000	23	M03	IEC71	0,75	2800
18000	12	M04	IEC71	0,37	2800
18000	6	M05	IEC71	0,37	1400
18000	3	M06	IEC71	0,37	1400

With single-phase motors type M (see motor choice guideline in paragraph ACCESSORIES) performances are 20% lower than the three-phase motor.

* When speed is more than 40 mm/s and/or strokes longer than 350mm, check STROKE SETUP section; BRAKEMOTOR IS RECOMMENDED

BEFORE OPERATING ACTUATOR MAKE SURE YOU READ AND UNDERSTOOD BASIC OPERATIONAL INSTRUCTIONS SHOWN ON USERMANUALS, AVAILABLE FROM WEBSITE.

THIS DOCUMENT DISPLAYS MOST TYPICAL STANDARD FEATURES AND SETUPS: CONTACT OUR OFFICES FOR MORE.

ACTUATOR SHALL NOT COME TO **MECHANICAL STROKE-END**, TO **AVOID FAILURES**.

CONSIDER MECVEL'S LIMITSWITCHES (MODEL ALI5-F or ALI5-FCM) OR PUT THEM ON MACHINE/FRAME.



MecVel reserves the right to change products information and/or features without notice; all data contained in this catalogue are purely indicative and not binding for the company.

AL15 Version without limitswitches

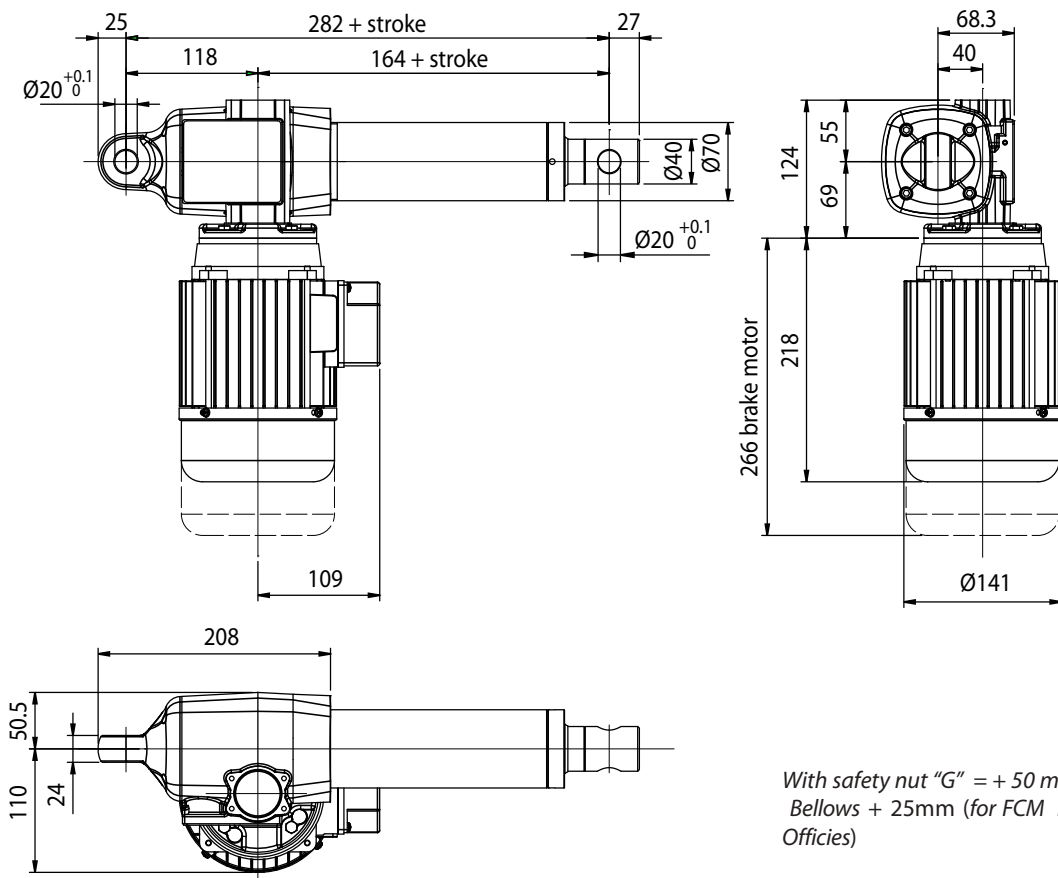

AL15-F Version with limitswitches

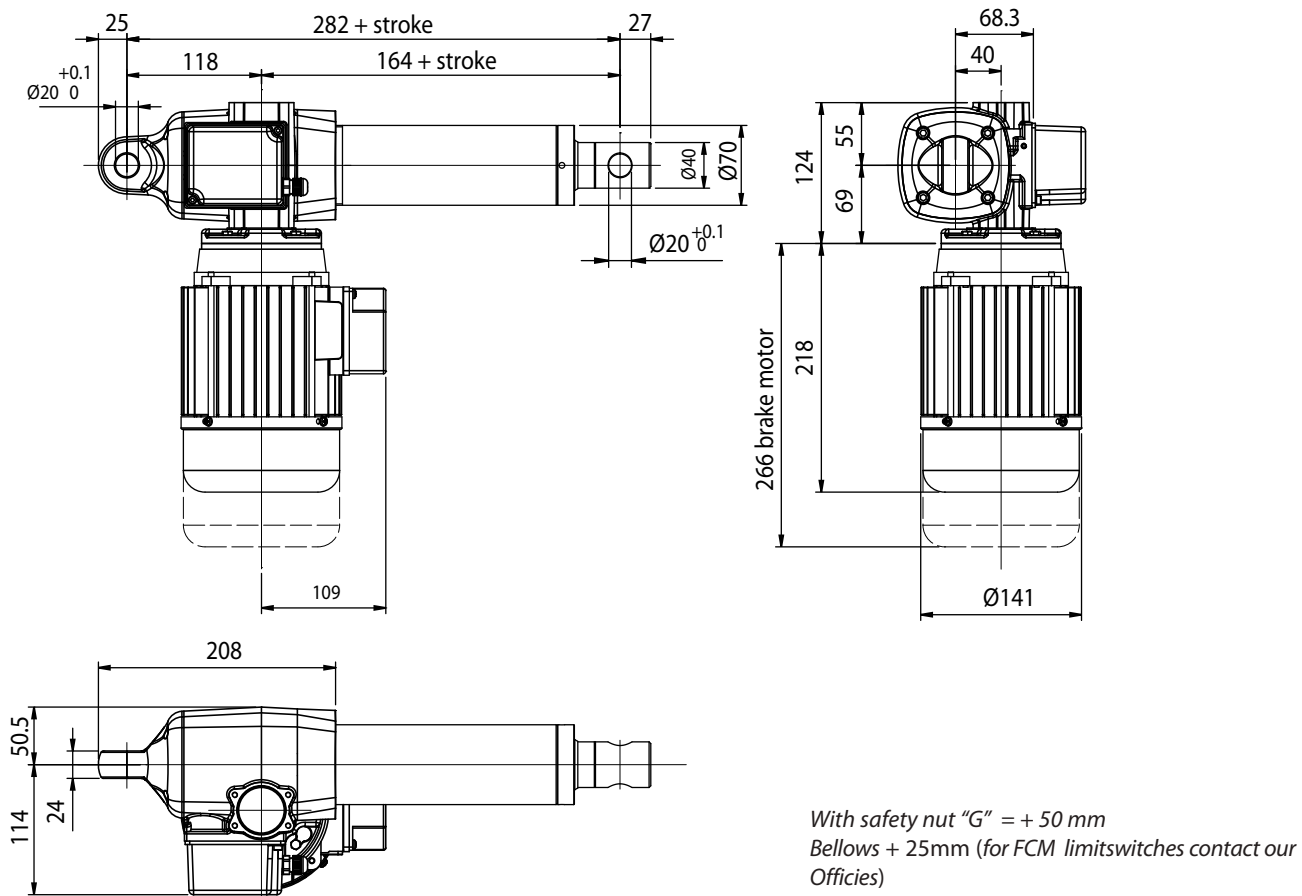

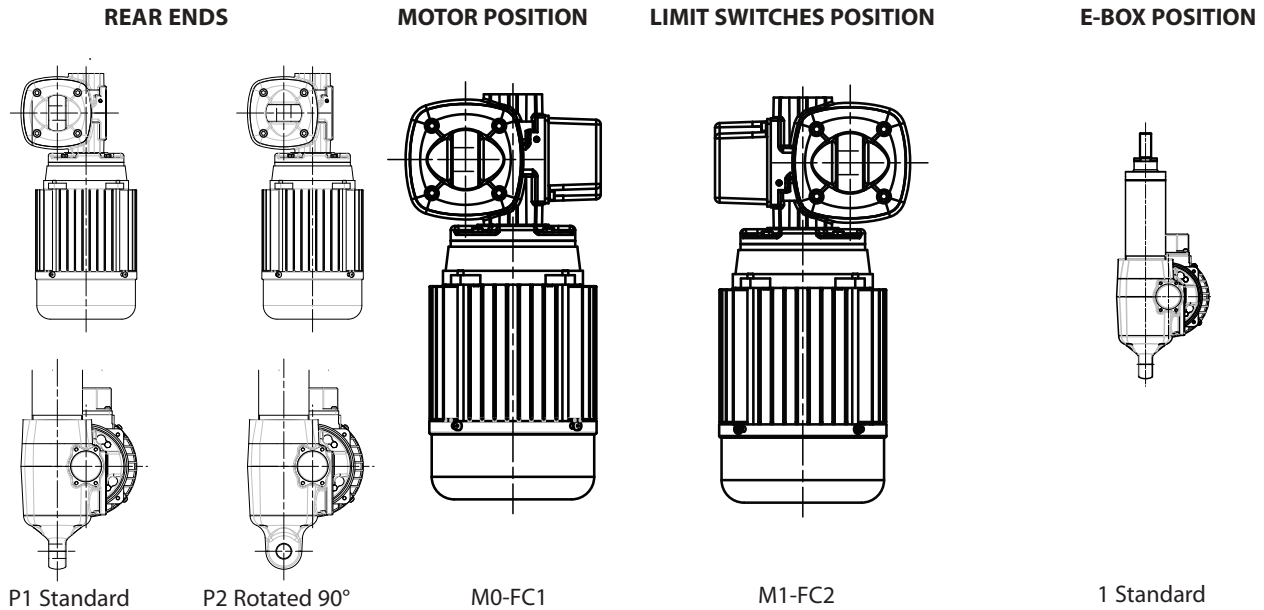

STROKE SETUP: Useful tips for handling stroke and avoid run-on-block collision.

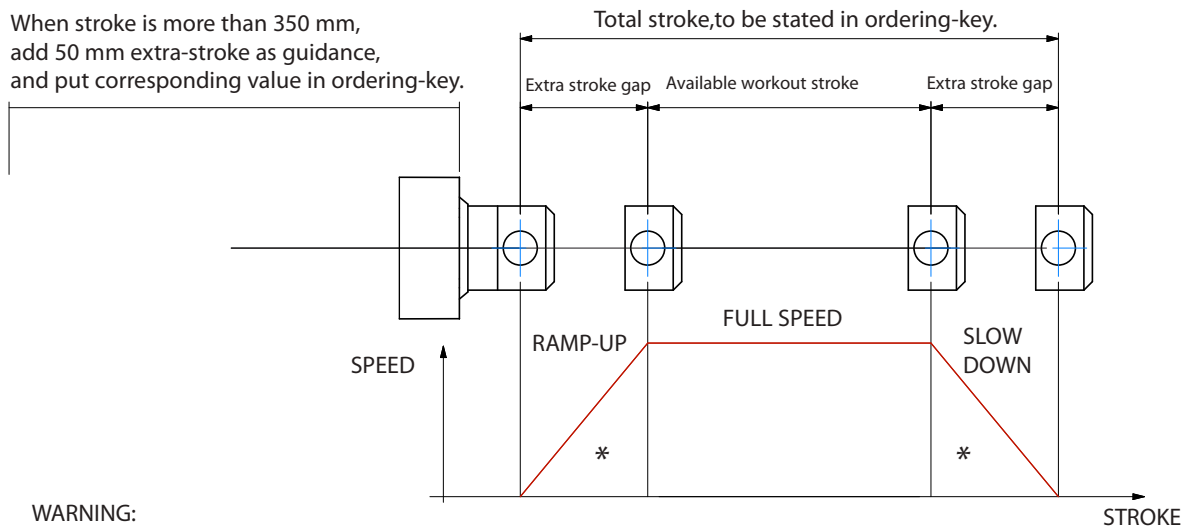

WARNING:
SPEED-TIMING ALONG STROKELENGTH:
 ramps are extremely important when speed is > 40m/s !!! Inverter or PWM drive recommended!
 * The more speed raises the more extra stroke has to raise too.

BUCKLING: When stroke is longer than 500mm, BUCKLING can be a risk: please check mounting with our offices and/or see user-manuals.

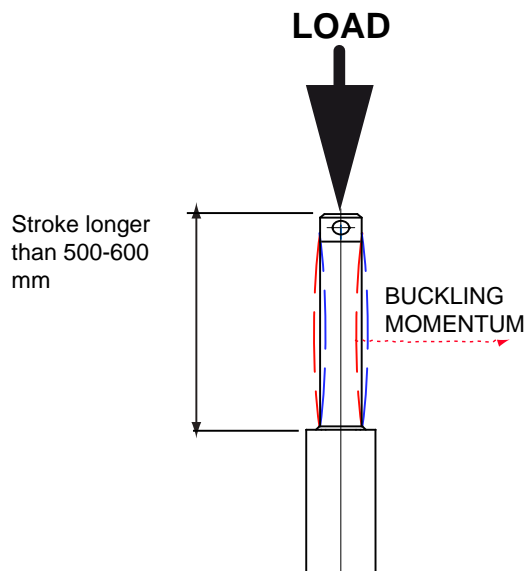

IMPORTANT:
 Long strokes, even if load is low, can generate significant buckling momentums, as sketch slows.
 This happens when actuator is in its all-opened position: that's the reason why we recommend 100 mm extra-stroke.
 Pushtube will have this 100 mm-portion always inside the overtube, improving guidance against buckling.
 For more information on this, contact our office.

ALI5 / 0300 / M01 / CA-400-50-T-71-2-0,55 / AB / M0-FC1 / 1 / E05 / 2FC2 / POT01A / P1 / A1

MODEL: _____
 ALI5 / ALI5-F / ALI5-FCM / ALI5-FCI
 ALI5-VRS / ALI5-F-VRS
 ALI5-VRS-FCM / ALI5-VRS-FCI

STROKE: _____
 es. 300 mm = 0300

VERSION: (pag.41) _____
 Advise: choose among
 Flanged Version = Rpm
 Advise reduction ratio and screw pitch (ALI5)

MOTOR: (pag. ACCESSORIES) _____
 Advise only if with motor:
 version, voltage, type, size, n°pole, power
 With motorflange only put 0
 With special motorflange put: PD

AC MOTOR OPTIONS: _____
 (pag. ACCESSORIES)
 Motorflange: for motorflange version only advise size - i.e.for IEC71 B14 put 71B14
 No motor: leave all following parameters blank
 Protection Degree: IP65, for selfbrake motor IP54 standard
 Brake type: for brakemotors only: ES. FECA
 Options: Advise if needed (ES. AB 2'shaft)

MOTOR LIMIT SWITCHES POSITION: _____

M0-FC1 / M1-FC2 None: Leave blank

E-BOX POSITION: _____
1 No Motor: Leave blank

ENCODER: (pag. ACCESSORIES) _____
 None: Leave blank

LIMIT SWITCHES: (pag. ACCESSORIES) _____
 None: Leave blank

POTENTIOMETER: (pag. ACCESSORIES) _____
POT01A (1Kohm) **POT10A** (10Kohm) None: Leave blank

REAR END: _____
P1 = Eyelet **P2** = Eyelet (90°)

FRONT END: _____
A1 = Eyelet (Std pag. 42) **A3** = Yoke + Clip
A4 = Rod end **A7** = M20x1,5 male

NOTE: COMPLETE THE ORDERING KEY ADDING THE OPTIONS YOU CAN FIND IN THE "ACCESSORIES AND OPTIONS" SECTION

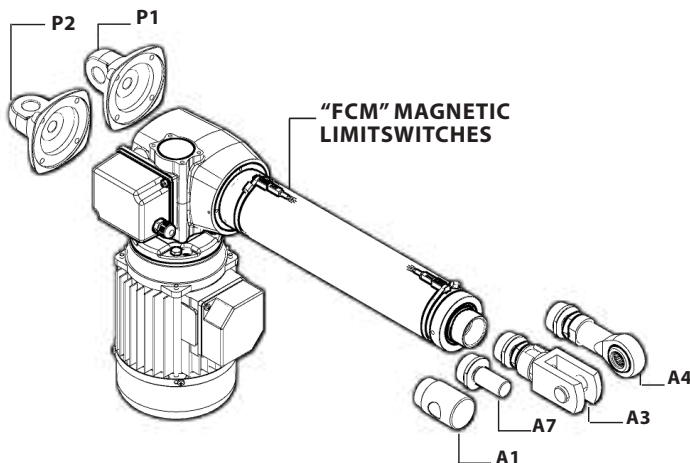

Note: "B" dimension variations depending on model

ALI5 / ALI5-F = See pictures	ALI5 / ALI5-F stroke > 500 = + 20 mm
ALI5-FCM stroke < 500 = + 40 mm	ALI5-FCM stroke > 500 = + 60 mm
ALI5-FCI stroke < 500 = + 30 mm	ALI5-FCI stroke > 500 = + 50 mm
ALI5-VRS ALI5-F-VRS stroke < 500 = + 88 mm	ALI5-VRS ALI5-F-VRS stroke > 500 = +108 mm
ALI5-VRS-FCM corsa stroke < 500 = + 128 mm	ALI5-VRS-FCM stroke > 500 = + 148 mm
ALI5-VRS-FCI stroke < 500 = + 118 mm	ALI5-VRS-FCI stroke > 500 = + 138 mm

with safety nut "G" = + 50 mm (Es. ALI5-F opzione "G" = +50) / (i.e. ALI5-F "G" option = +50)
 antirotation device "L" = + 15 mm
 Bellows = + 25 (excluding FCM and FCI version, for version FCM and FCI contact MecVel)

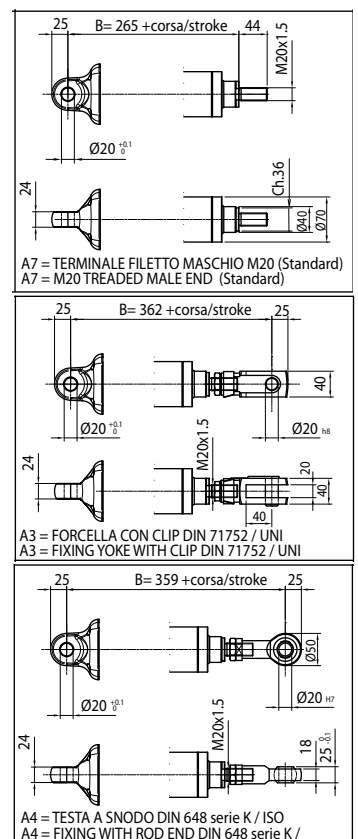

ALI5-P Cross gears CE ALI5-PB Belt drive

- Three phase or single phase motor CE
 - Cross gears (ALI5-P)
 - Belt drive (ALI5-PB)
 - Acme lead screw or ballscrew (VRS)
 - Chrome plated steel push road
 - Grease (standard) or oil (VRS continuous duty S1) lubricated only P version
 - IP65, tested according to rule CEI EN 60529
 - NB: Only for brake motors Standard IP54, IP65 on request
 - Working temperature range -10°C +60°C
 - Intermittent duty S3 30% (5min) a +30°C acme lead screw version (*)
 - Continuous duty S1 +30°C ballscrew version (**)
 - Limit switch, potentiometer, encoder on request
 - At-Ex II 3 D T4 version (A.C.motor) on request
- (*) For any special duty, please contact our technical department
(**) Performance are related to ball screw, lifetime of 2000 hours with steady load and without shocks or vibrations

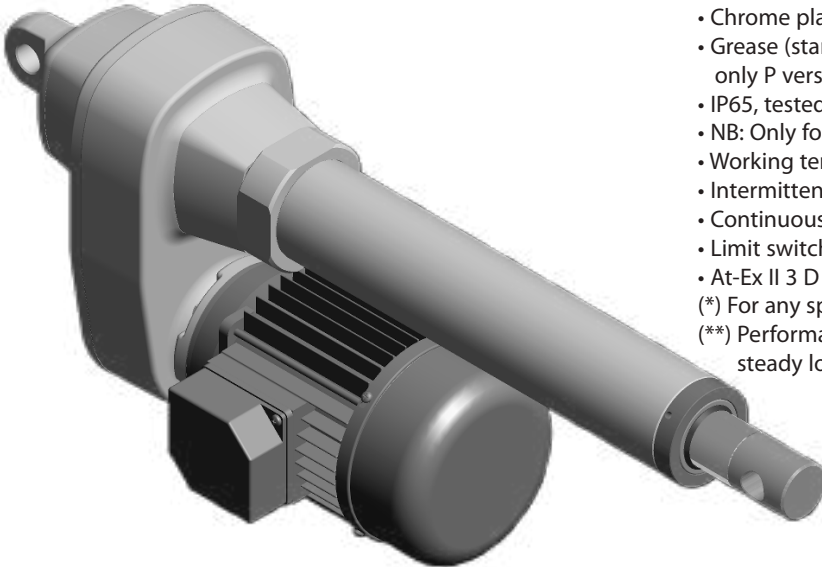

ALI5P - AC - ACME LEAD SCREW - S3 30% (5 min) 30°C					
Fmax (N)	Speed (mm/s)	Version	Motor size	Motor power (KW)	Motor speed (rpm)
* 2700	113	M11	IEC71	0.55	2800
* 4000	57	M12	IEC71	0.37	1400
6600	28	M13	IEC71	0.37	1400
15000	14	M14	IEC71	0.37	1400
15000	9	M15	IEC71	0.37	1400
15000	5	M16	IEC71	0.25	1400

ALI5P - AC - BALLSCREW - S1					
Fmax (N)	Speed (mm/s)	Version	Motor size	Motor power (KW)	Motor speed (rpm)
* 3900	113	M56	IEC71	0.55	2800
* 5500	57	M57	IEC71	0.37	1400
7000	28	M58	IEC71	0.37	1400
9000	14	M59	IEC71	0.25	1400
10000	9	M60	IEC71	0.25	1400

ALI5PB - AC - ACME LEAD SCREW - S3 30% (5 min) 30°C					
Fmax (N)	Speed (mm/s)	Version	Motor size	Motor power (KW)	Motor speed (rpm)
* 2800	233	M17	IEC80	1.10	2800
* 3300	194	M18	IEC80	1.10	2800
* 4600	117	M19	IEC80	1.10	2800
* 5500	97	M20	IEC80	1.10	2800
* 6900	58	M21	IEC80	0.75	1400
* 8300	49	M22	IEC80	0.75	1400

ALI5PB - AC - VRS - BALLSCREW - S1					
Fmax (N)	Speed (mm/s)	Version	Motor size	Motor power (KW)	Motor speed (rpm)
* 3600	223	M61	IEC80	1.10	2800
* 3800	194	M62	IEC80	1.10	2800
* 4300	117	M63	IEC80	0.75	1400
* 4500	97	M64	IEC80	0.55	1400
* 4500	49	M65	IEC71	0.25	1400

With single-phase motors type M (see motor choice guideline in paragraph ACCESSORIES) performances are 20% lower than the three-phase motor.

* When speed is more than 40 mm/s and/or strokes longer than 350mm, check STROKE SETUP section; BRAKEMOTOR IS RECOMMENDED

BEFORE OPERATING ACTUATOR MAKE SURE YOU READ AND UNDERSTOOD BASIC OPERATIONAL INSTRUCTIONS SHOWN ON USERMANUALS, AVAILABLE FROM WEBSITE.

THIS DOCUMENT DISPLAYS MOST TYPICAL STANDARD FEATURES AND SETUPS: CONTACT OUR OFFICES FOR MORE.

ACTUATOR SHALL NOT COME TO **MECHANICAL STROKE-END**, TO **AVOID FAILURES**.

CONSIDER MECVEL'S LIMITSWITCHES (MODEL ALI5-P-F or ALI5-PB-F) OR PUT THEM ON MACHINE/FRAME.



MecVel reserves the right to change products information and/or features without notice; all data contained in this catalogue are purely indicative and not binding for the company.

ALI5-P-PB Version without limitswitches

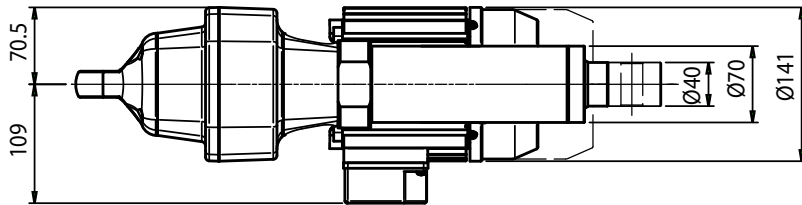
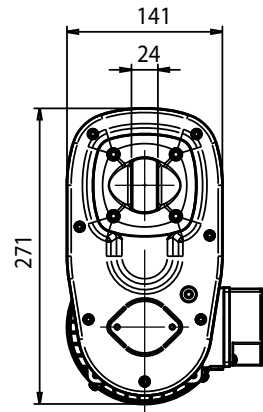
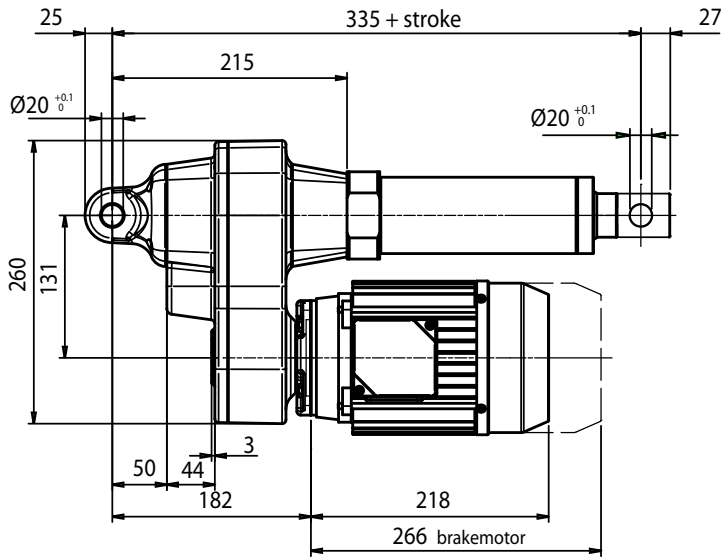

With safety nut "G" = + 50 mm
 Bellows + 25mm (for FCM limitswitches contact our Offices)

ALI5-P ALI5-PB

REAR ENDS

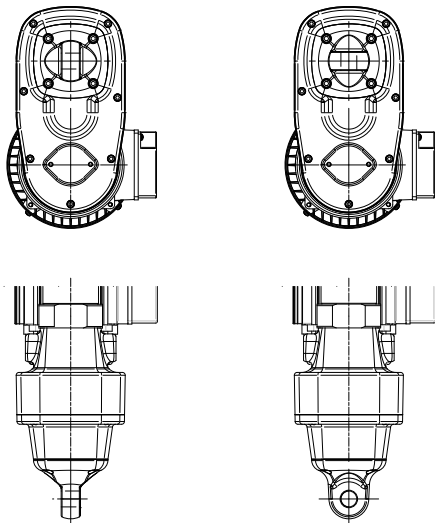

P1 Standard

P2 Ruotato 90°

E-BOX POSITION

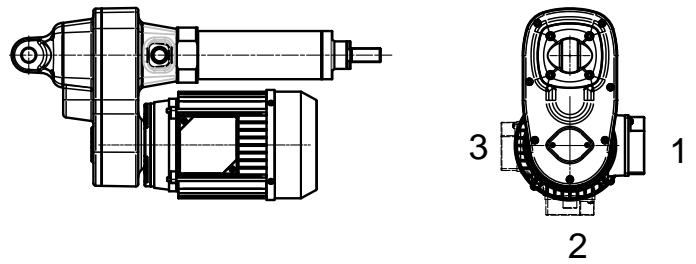

STROKE SETUP: Useful tips for handling stroke and avoid run-on-block collision.

When stroke is more than 350 mm, add 50 mm extra-stroke as guidance, and put corresponding value in ordering-key.

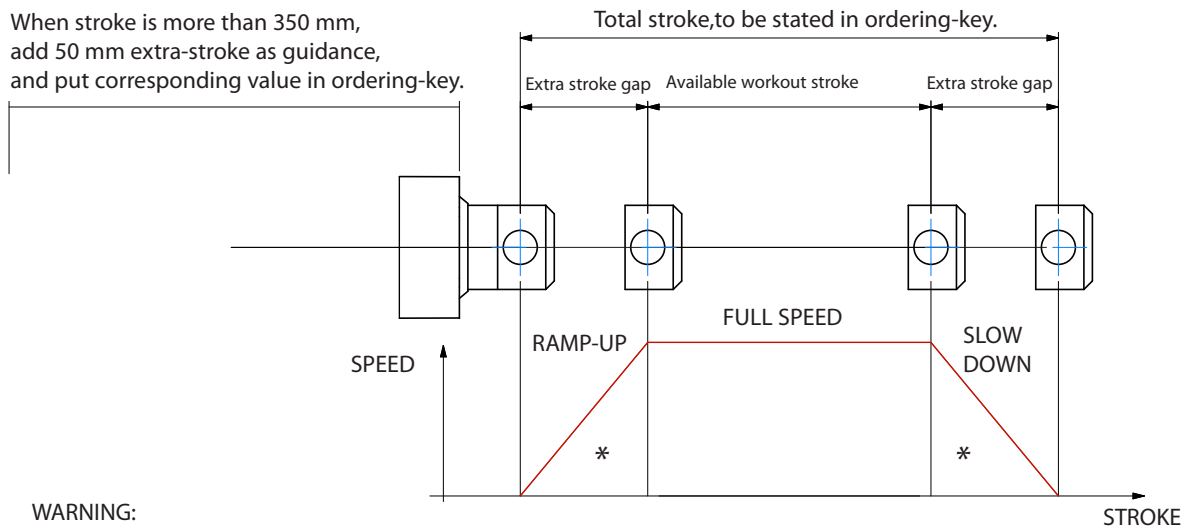

WARNING:

SPEED-TIMING ALONG STROKELENGTH:

ramps are extremely important when speed is > 40mm/s !!! Inverter or PWM drive recommended!

* The more speed raises the more extra stroke has to raise too.

BUCKLING: When stroke is longer than 500mm, BUCKLING can be a risk: please check mounting with our offices and/or see user-manuals.

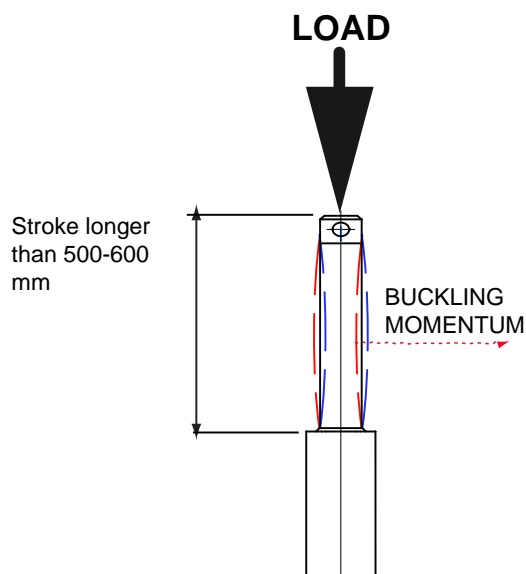

IMPORTANT:

Long strokes, even if load is low, can generate significant buckling momentums, as sketch slows.

This happens when actuator is in its all-opened position: that's the reason why we recommend 100 mm extra-stroke.

Pushtube will have this 100 mm-portion always inside the overtube, improving guidance against buckling.

For more information on this, contact our office.

ALI5-P / 0300 / M01 / CA-400-50-T-71-2-0,55 / B5 + AB / 1 / E05 / 2FCM0 / POT01A / P1 / A1

MODEL: _____
 ALI5-P / ALI5-PB / ALI5-P-FCM / ALI5-P-FCI
 ALI5-P-VRS / ALI5-P-VRS
 ALI5-P-VRS-FCM / ALI5-P-VRS-FCI

STROKE: _____
 es. 300 mm = 0300

VERSION: (pag.45) _____
 Advise: choose among
 Flanged Version = Rpm
 Advise reduction ratio and screw pitch (ALI5)

MOTOR: (pag. ACCESSORIES) _____
 Advise only if with motor:
 version, voltage, type, size, n°pole, power
 With motorflange only put 0
 With special motorflange put: PD

AC MOTOR OPTIONS: (pag. ACCESSORIES) _____
 Motorflange: for motorflange version only advise size - i.e.for IEC71 B14 put 71B14
 No motor: leave all following parameters blank
 Protection Degree: IP65, for selfbrake motor IP54 standard
 Brake type: for brakemotors only: ES. FECA
 Options: Advise if needed (ES. AB 2'shaft)

E-BOX POSITION: _____
 1 No Motor: Leave blank

ENCODER: (pag. ACCESSORIES) _____
 None: Leave blank

LIMIT SWITCHES: (psg. ACCESSORIES) _____
 None: Leave blank

POTENTIOMETER: (psg. ACCESSORIES) _____
POT01A (1Kohm) **POT10A** (10Kohm) None: / Leave blank

REAR END: _____
P1 = Eyelet **P2** = Eyelet (90°)

FRONT END: _____
A1 = Eyelet (Std pag. 46) **A3** = Yoke + Clip
A4 = Rod end **A7** = M20x1,5 male

NOTE: COMPLETE THE ORDERING KEY ADDING THE OPTIONS YOU CAN FIND IN THE "ACCESSORIES AND OPTIONS" SECTION

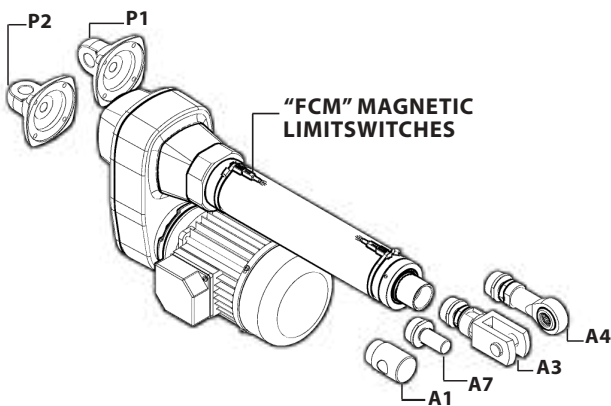

Note: "B" dimension variations depending on model

- | | |
|--|--|
| ALI5-P = See pictures | ALI5-P stroke > 500 = + 20 mm |
| ALI5-P-FCM stroke < 500 = + 40 mm | ALI5-P-FCM stroke > 500 = + 60 mm |
| ALI5-P-FCI stroke < 500 = + 30 mm | ALI5-P-FCI stroke > 500 = + 50 mm |
| ALI5-P-VRS stroke < 500 = + 88 mm | ALI5-P-VRS stroke > 500 = + 108 mm |
| ALI5-P-VRS-FCM stroke < 500 = + 128 mm | ALI5-P-VRS-FCM stroke > 500 = + 148 mm |
| ALI5-P-VRS-FCI stroke < 500 = + 118 mm | ALI5-P-VRS-FCI stroke > 500 = + 138 mm |

with safety nut "G" = + 50 mm (i.e. ALI5-P "G" option = +50)
 antirotation device "L" = + 15 mm
 Bellows = + 25 mm (excluding FCM and FCI. For version FCM and FCI contact MecVel)

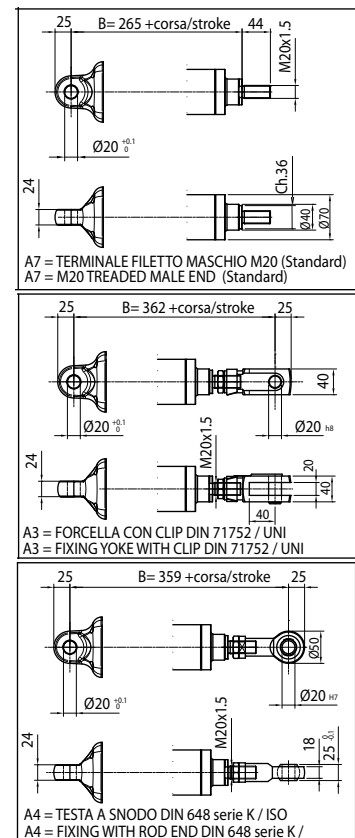

Model AV3

- A.C. motor, flange B14 - CE
 - Worm gearbox
 - Acme lead screw or ballscrew (VRS)
 - Chrome plated steel push rod
 - Grease Lubricated
 - IP 65, tested according to rule CEI EN 60529
 - NB: Only for brake motors Standard IP54, IP65 on request
 - Working temperature range -10°C +60°C
 - Intermittent duty S3 30% (5 min) a 30°C(*)
 - Limit switches on request
 - Potentiometer and encoder on request
- (*) For any special duty please contact our technical dept.

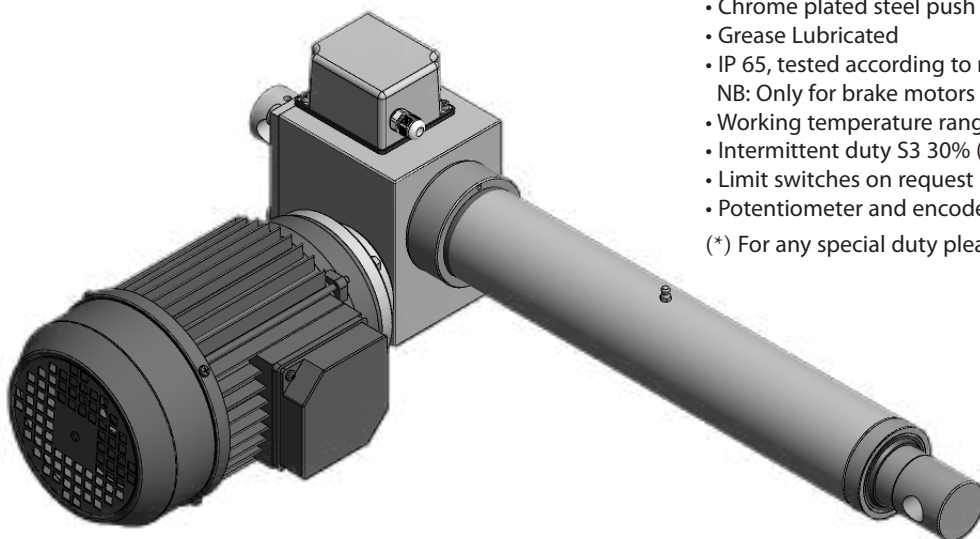

AV3 (Vac 3-phase)					
Fmax (N)	Speed (mm/s)	Version	Motor size	Motor power (KW)	Motor speed (rpm)
* 13000	55	M01	IEC90	3.00	2800
20000	30	M02	IEC90	3.00	2800
25000	20	M03	IEC80	1.80	2800
25000	10	M04	IEC80	1.10	1400
25000	5	M05	IEC80	0.75	1400

AV3 VRS (ballscrew) (Vac 3-phase)					
Fmax (N)	Speed (mm/s)	Version	Motor size	Motor power (KW)	Motor speed (rpm)
* 8000	45	M01	IEC80	0.75	2800
13000	22	M02	IEC80	0.55	1400
25000	15	M03	IEC80	0.75	2800
25000	7	M04	IEC80	0.55	1400

With single-phase motors type M (see motor choice guideline in paragraph ACCESSORIES) performances are 20% lower than the three-phase motor.

* When speed is more than 40 mm/s and/or strokes longer than 350mm, check STROKE SETUP section; BRAKEMOTOR IS RECOMMENDED

BEFORE OPERATING ACTUATOR MAKE SURE YOU READ AND UNDERSTOOD BASIC OPERATIONAL INSTRUCTIONS SHOWN ON USERMANUALS, AVAILABLE FROM WEBSITE.

THIS DOCUMENT DISPLAYS MOST TYPICAL STANDARD FEATURES AND SETUPS: CONTACT OUR OFFICES FOR MORE.

ACTUATOR SHALL NOT COME TO **MECHANICAL STROKE-END**, TO **AVOID FAILURES**.

CONSIDER MECVEL's LIMITSWITCHES (MODEL AV3-F or AV3-FCM) OR PUT THEM ON MACHINE/FRAME.



MecVel reserves the right to change products information and/or features without notice; all data contained in this catalogue are purely indicative and not binding for the company.

AV3-F Version with limitswitches

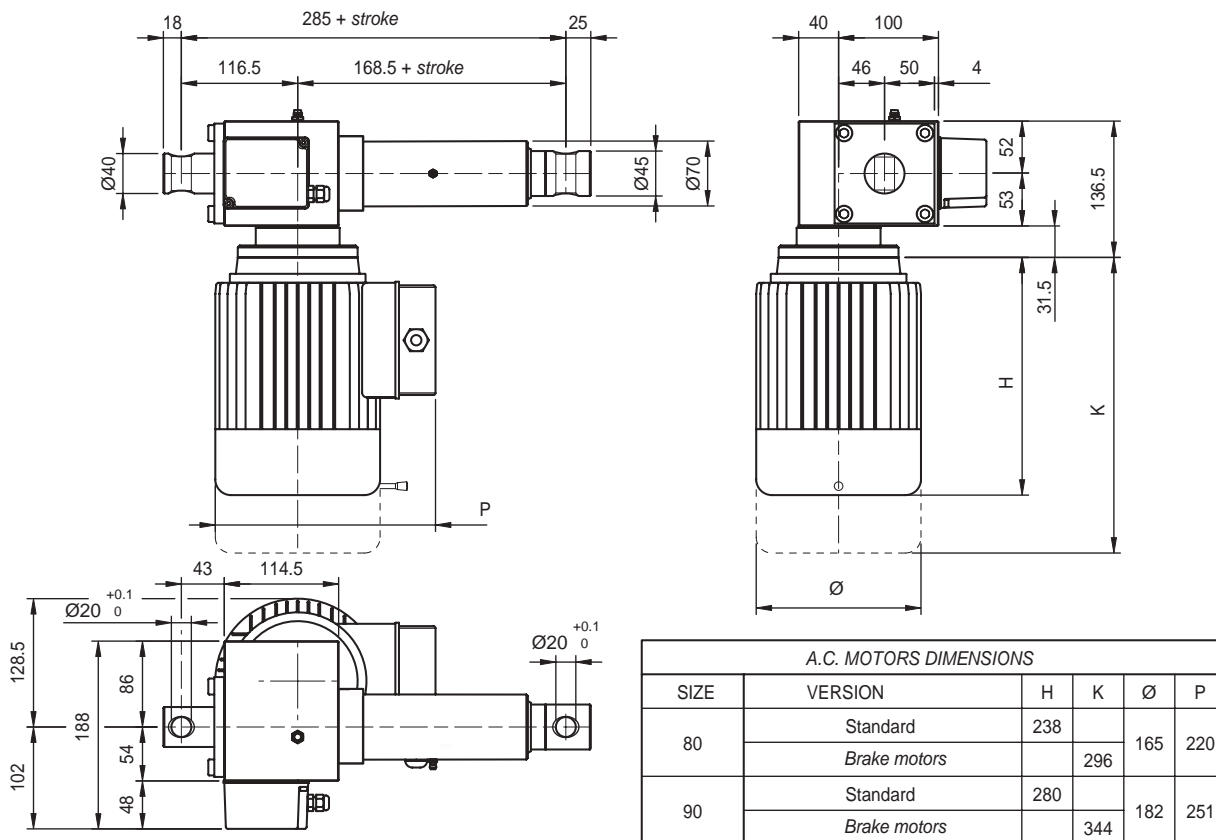

REAR ENDS

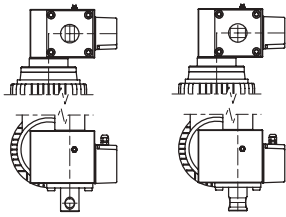

P1 Standard

P2 Rotated 90°

E-BOX POSITION

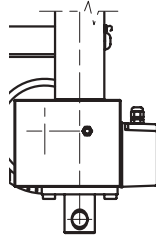

1 Standard

MOTOR AND LIMIT SWITCHES POSITION

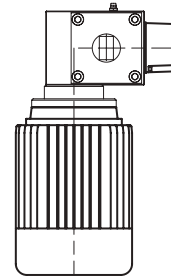

M1-FC1
Standard

STROKE SETUP: Useful tips for handling stroke and avoid run-on-block collision.

When stroke is more than 350 mm, add 50 mm extra-stroke as guidance, and put corresponding value in ordering-key.

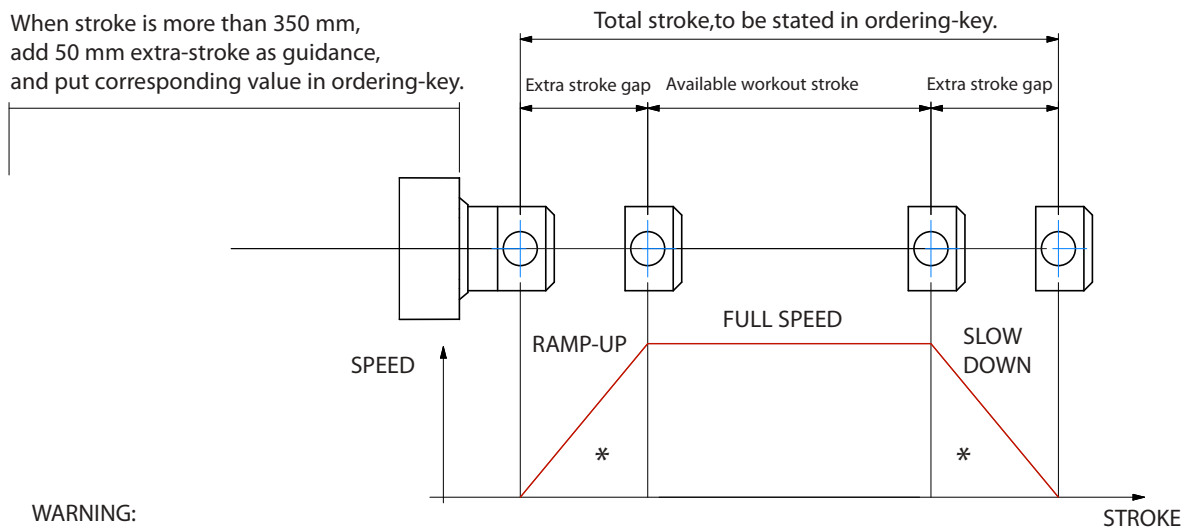

WARNING:

SPEED-TIMING ALONG STROKELENGTH:

ramps are extremely important when speed is > 40mm/s !!! Inverter or PWM drive recommended!

* The more speed raises the more extra stroke has to raise too.

BUCKLING: When stroke is longer than 500mm, BUCKLING can be a risk: please check mounting with our offices and/or see user-manuals.

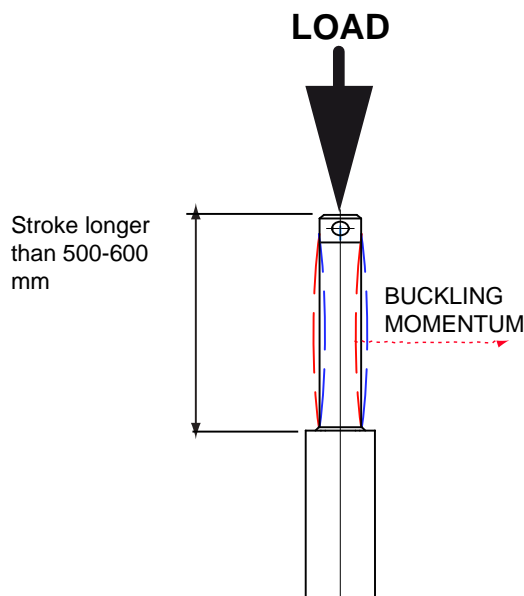

IMPORTANT:

Long strokes, even if load is low, can generate significant buckling momentums, as sketch slows.

This happens when actuator is in its all-opened position: that's the reason why we recommend 100 mm extra-stroke.

Push tube will have this 100 mm-portion always inside the over tube, improving guidance against buckling.

For more information on this, contact our office.

AV3 / 0250 / M01 / CA-400/50-T-56-4-0,09 / AB / M1-FC1 / 1 / E05 / 2FC2 / P0T01A / P1 / A1

MODEL: _____

AV3 AV3-VRS

STROKE: _____
es. 250 mm = 0250

VERSION: (pag. 49) _____
M01 / M02 / M03 / M04 / M05
M01 / M02 / M03 / M04 (Version VRS ballscrew)
M00 = Not standard speed
Flanged Version = Rpm
Advise reduction ratio and screw pitch

MOTOR: (pag. ACCESSORIES) _____
Advise only if with motor:
version, voltage, type, size, n°pole, power
With motorflange only put 0
With special motorflange put: PD

AC MOTOR OPTIONS: (pag. ACCESSORIES) _____
Motorflange: for motorflange version only advise size - i.e.for IEC80 B14 put 80B14
No motor: leave all following parameters blank
Protection Degree: IP65, for selfbrake motor IP54 standard
Brake type: for brakemotors only: ES. FECA
Options: Advise if needed (ES. AB 2'shaft)

MOTOR AND LIMIT SWITCHES POSITION: _____
M1-FC1 None: Leave blank

E-BOX POSITION: _____
1 No Motor: Leave blank

ENCODER: (pag. ACCESSORIES) _____
None: Leave blank

LIMIT SWITCHES: (pag. ACCESSORIES) _____
None: Leave blank

POTENTIOMETER: (pag. ACCESSORIES) _____
POT01A (1Kohm) **POT10A** (10Kohm) None: Leave blank

REAR END: _____
P1 = Eyelet (standard) **P2** = Eyelet (90°)

FRONT END: _____
A1 = Eyelet (Std pag.50) **A4** = Rod end
A3 = Yoke + Clip **A7** = M12 male

NOTE: COMPLETE THE ORDERING KEY ADDING THE OPTIONS YOU CAN FIND IN THE "ACCESSORIES AND OPTIONS" SECTION _____

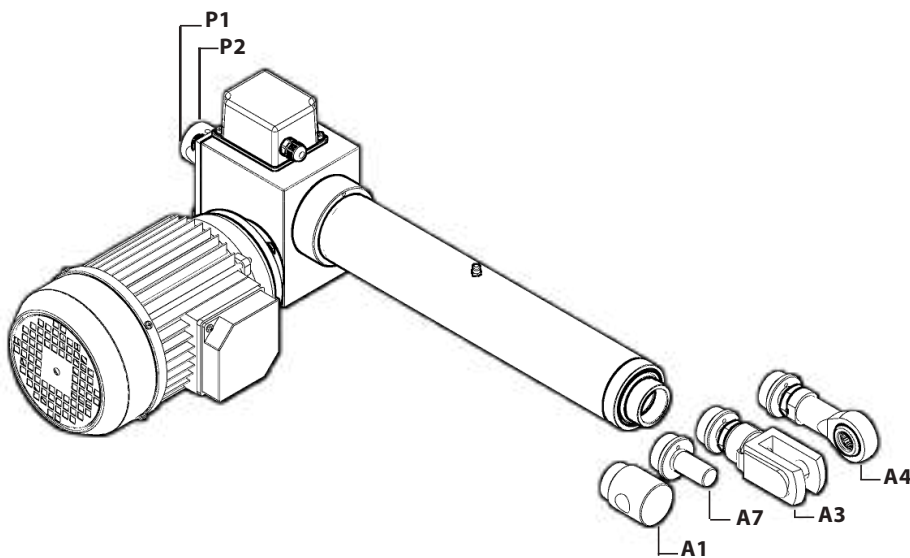

Note: "B" dimension changes according to model

- AV3 = See pictures
- With safety nut "G" = + 40 mm
- AV3-VRS = + 20 mm
- Bellows = + 25mm

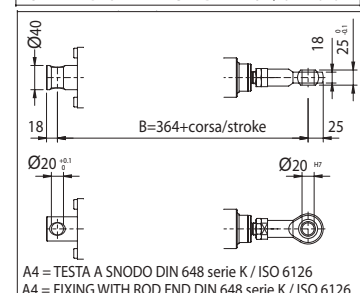
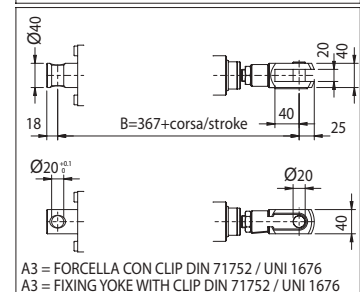
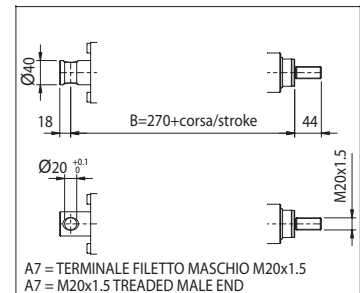

ECV9092 Model C€

- A.C. motor, flange B5 - CE
 - Worm gearbox
 - Acme lead screw or ballscrew (VRS) (**)
 - Chrome plated steel push rod
 - Grease Lubricated
 - IP 65, tested according to rule CEI EN 60529
NB: Only for brake motors Standard IP54, IP65 on request
 - Working temperature range -10 C°+60 C°
 - Intermittent duty S3 30% (5 min) a 30°C (*)
 - Integrated Limit switches on request
 - Potentiometer and encoder on request
- (*) For any special duty please contact our technical dept.
(**) Contact our technical dept.

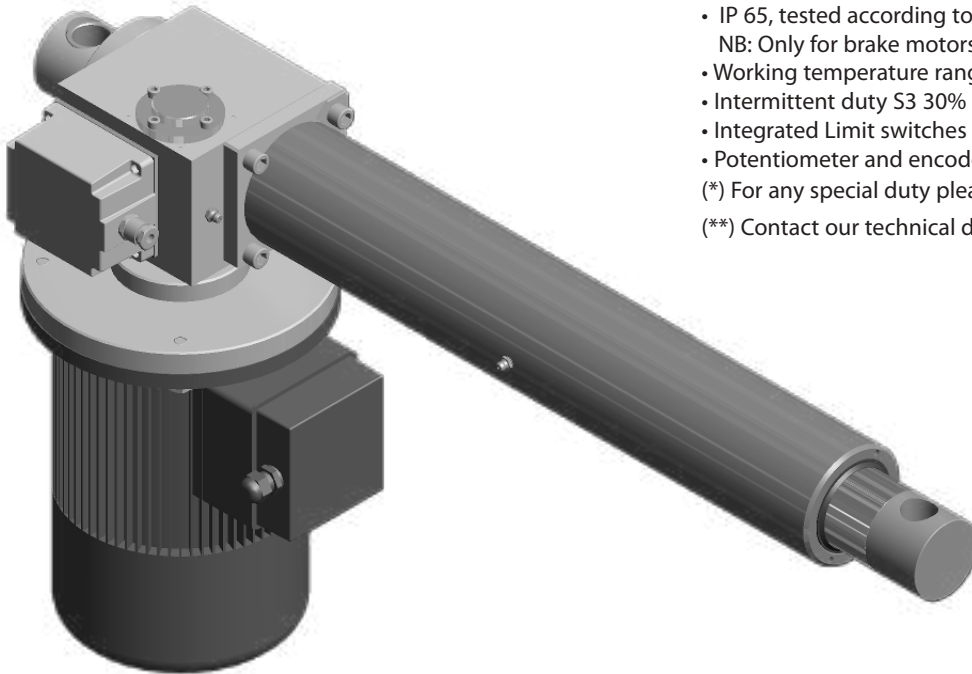

ECV9092 (Vac 3-phase)

<i>Fmax</i> (N)	<i>Speed</i> (mm/s)	<i>Version</i>	<i>Motor size</i>	<i>Motor power</i> (KW)	<i>Motor speed</i> (rpm)
* 15000	45	M01	IEC100	0.09	1400
25000	24	M02	IEC100	0.09	1400
40000	10	M03	IEC100	0.09	1400
40000	5	M04	IEC90	0.09	1400

With single-phase motors type M (see motor choice guideline in paragraph ACCESSORIES) performances are 20% lower than the three-phase motor.

* When speed is more than 40 mm/s and/or strokes longer than 350mm, check STROKE SETUP section; BRAKEMOTOR IS RECOMMENDED

BEFORE OPERATING ACTUATOR MAKE SURE YOU READ AND UNDERSTOOD BASIC OPERATIONAL INSTRUCTIONS SHOWN ON USERMANUALS, AVAILABLE FROM WEBSITE.

THIS DOCUMENT DISPLAYS MOST TYPICAL STANDARD FEATURES AND SETUPS: CONTACT OUR OFFICES FOR MORE.

ACTUATOR SHALL NOT COME TO **MECHANICAL STROKE-END**, TO **AVOID FAILURES**.

CONSIDER MECVEL's LIMITSWITCHES (MODEL AV3-F or AV3-FCM) OR PUT THEM ON MACHINE/FRAME.



MecVel reserves the right to change products information and/or features without notice; all data contained in this catalogue are purely indicative and not binding for the company.

ECV9092 Version with limitswitches

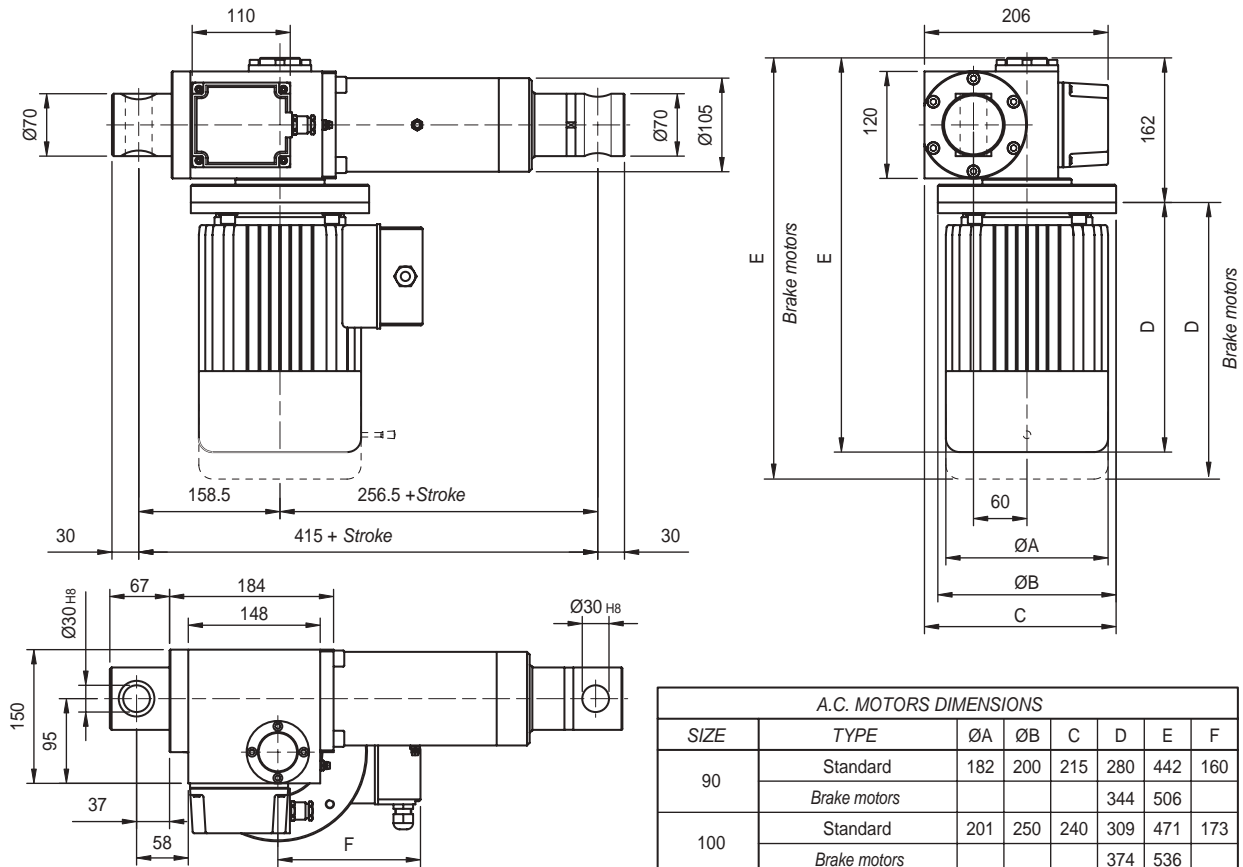

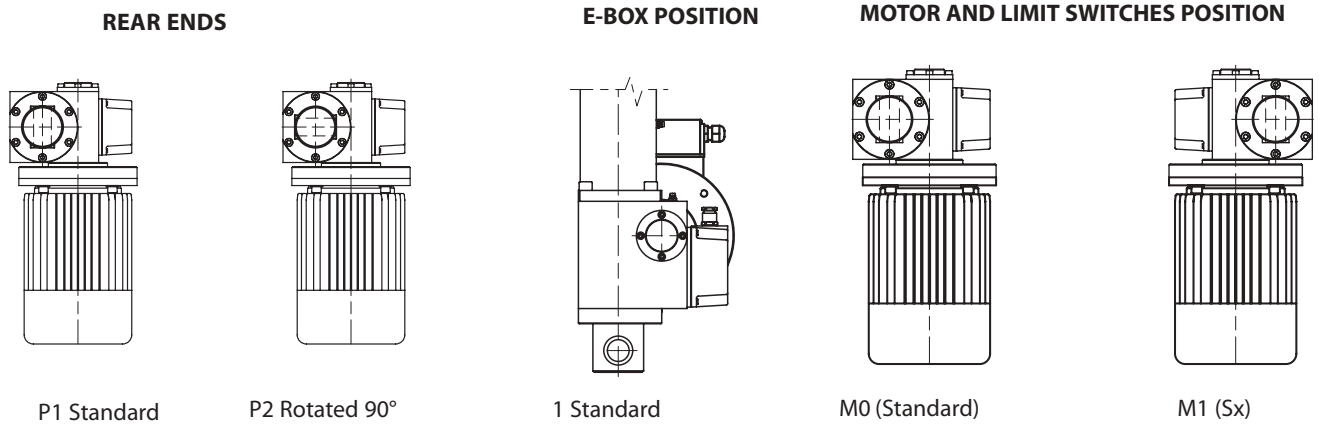

STROKE SETUP: Useful tips for handling stroke and avoid run-on-block collision.

When stroke is more than 350 mm, add 50 mm extra-stroke as guidance, and put corresponding value in ordering-key.

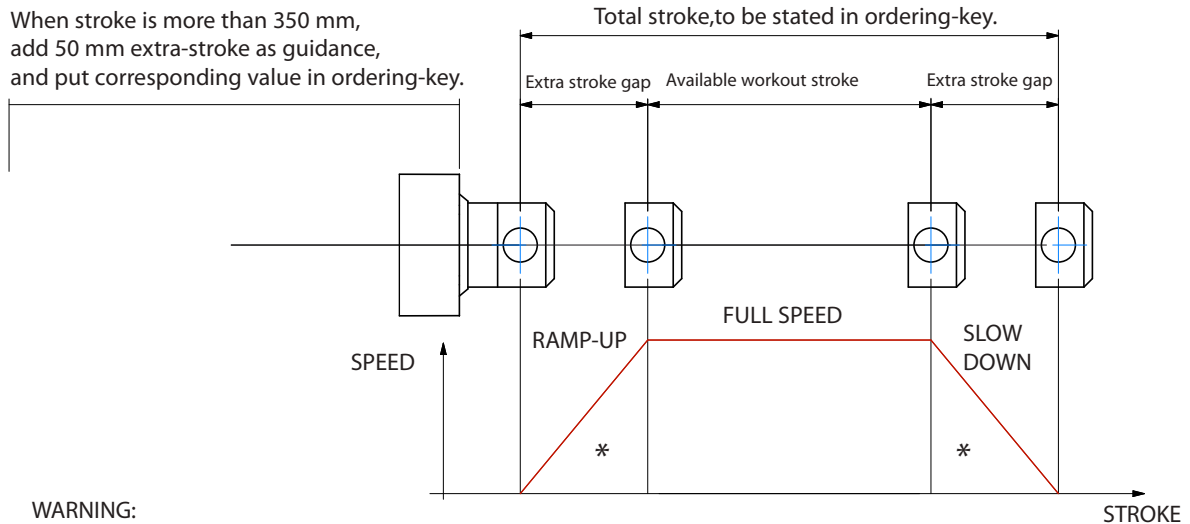

WARNING:
SPEED-TIMING ALONG STROKELENGTH:
 ramps are extremely important when speed is > 40mm/s !!! Inverter or PWM drive recommended!
 * The more speed raises the more extra stroke has to raise too.

BUCKLING: When stroke is longer than 500mm, BUCKLING can be a risk: please check mounting with our offices and/or see user-manuals.

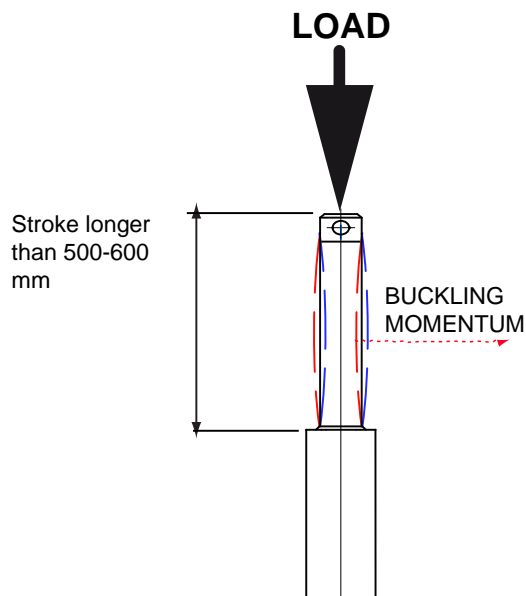

IMPORTANT:
 Long strokes, even if load is low, can generate significant buckling momentums, as sketch shows.
 This happens when actuator is in its all-opened position: that's the reason why we recommend 100 mm extra-stroke.
 Pushtube will have this 100 mm-portion always inside the overtube, improving guidance against buckling.
 For more information on this, contact our office.

ECV9092 / 0250 / M01 / CA-400/50-T-90-4-1,5 / 90B5+AB / 1 / M1 / E05 / 2FC2 / P0T01A / P1 / A1

MODEL: _____
ECV9092

STROKE: mm _____
es. 250 mm = 0250

VERSION: (pag. 53) _____
M01 / M02 / M03 / M04
M00 = Not standard speed
Flanged Version:
Advise reduction ratio and screw pitch

MOTOR: (pag. ACCESSORIES) _____
Advise only if with motor:
version, voltage, type, size, n°pole, power
With motorflange only put 0
With special motorflange put: PD

AC MOTOR OPTIONS: (pag. ACCESSORIES) _____
Motorflange: for motorflange version only advise size - i.e.for IEC80 B14 put 80B14
No motor: leave all following parameters blank
Protection Degree: IP65, for selfbrake motor IP54 standard
Brake type: for brakemotors only: ES. FECA
Options: Advise if needed (ES. AB 2'shaft)

E-BOX POSITION: _____
1 No motor: Leave blank

MOTOR POSITION: _____
M0 = standard M1 = SX

ENCODER: (pag. ACCESSORIES) _____
None: Leave blank

LIMIT SWITCHES: (pag. ACCESSORIES) _____
None: Leave blank

POTENTIOMETER: (pag. ACCESSORIES) _____
POT01A (1Kohm) POT10A (10Kohm) None: Leave blank

REAR END: _____
P1 = Eyelet (standard) P2 = Eyelet (90°)

FRONT END: _____
A1 = Eyelet (Std pag. 54) A3 = Yoke + Clip
A4 = Rod end A7 = M12 male

NOTE: COMPLETE THE ORDERING KEY ADDING THE OPTIONS YOU CAN FIND IN THE "ACCESSORIES AND OPTIONS" SECTION. _____

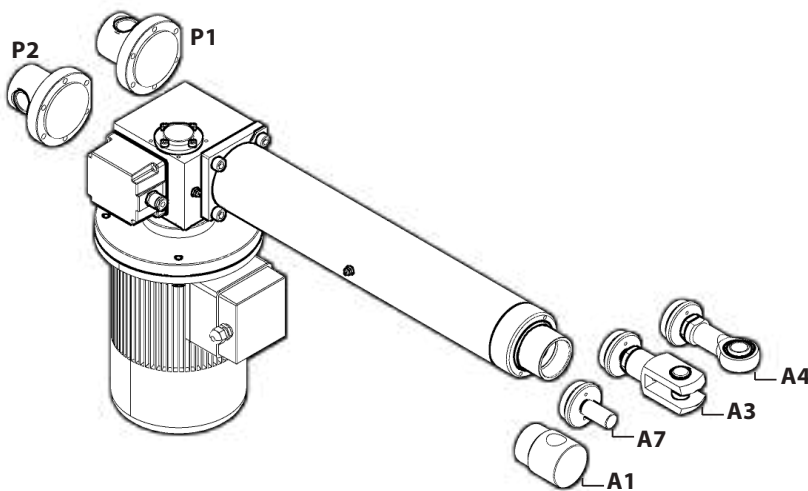

Note: "B" dimension changes according to model
ECV9092 = See pictures
Bellows = + 25 mm
with safety nut "G" = +50 mm

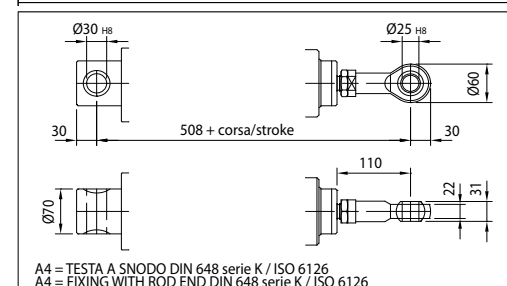
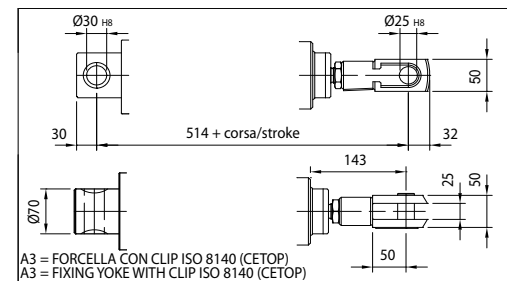
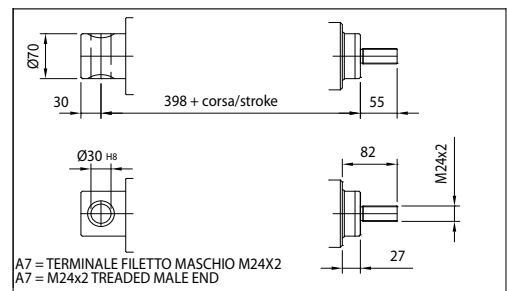

L02-Model C€

- Permanent magnet motor
- Planetary gearbox
- Acme lead screw or ballscrew (VRS)
- Chrome plated steel push rod
- Permanent grease lubrication
- IP 65, tested according to rule CEI EN 60529
- Working temperature range -10°C +60°C
- Intermittent duty (see performance charts) a 30°C*
- Limit switches on request
- Encoder on request

(*) For any special duty please contact our technical dept.



L02 (Vdc)							
Fmax (N)	Speed (mm/s)	Version	Motor size	Motor power (KW)	Motor speed (rpm)	Max Current for Fmax(A) 24Vdc	
* 280	100	M01	36	-	500	4	
* 220	60	M02	36	-	300	1,8	
* 240	40	M03	36	-	300	1,8	
	750	30	M04	36	-	150	2,8
	840	20	M05	36	-	150	2,8
	1600	10	M06	36	-	150	2,6
	2000	5	M07	36	-	80	1,7

L02 (Vdc) ballscrew							
Fmax (N)	Speed (mm/s)	Version	Motor size	Motor power (KW)	Motor speed (rpm)	Max Current for Fmax(A) 24Vdc	
* 1000	42	M01	36	-	500	4	
	1000	25	M02	36	-	300	1,7
	2000	12	M03	36	-	150	2
	2000	6	M04	36	-	80	1,2

* When speed is more than 40 mm/s and/or strokes longer than 350mm, check STROKE SETUP section.

** For 12 Vdc power supply currents are doubled and loads are 20% lower.

BEFORE OPERATING ACTUATOR MAKE SURE YOU READ AND UNDERSTOOD BASIC OPERATIONAL INSTRUCTIONS SHOWN ON USERMANUALS, AVAILABLE FROM WEBSITE.

THIS DOCUMENT DISPLAYS MOST TYPICAL STANDARD FEATURES AND SETUPS: CONTACT OUR OFFICES FOR MORE.

ACTUATOR SHALL NOT COME TO **MECHANICAL STROKE-END**, TO **AVOID FAILURES**.

CONSIDER MECVEL'S LIMITSWITCHES (MODEL L02-F or L02-FCM) OR PUT THEM ON MACHINE/FRAME.



MecVel reserves the right to change products information and/or features without notice; all data contained in this catalogue are purely indicative and not binding for the company.

L02 Version without limitswitches

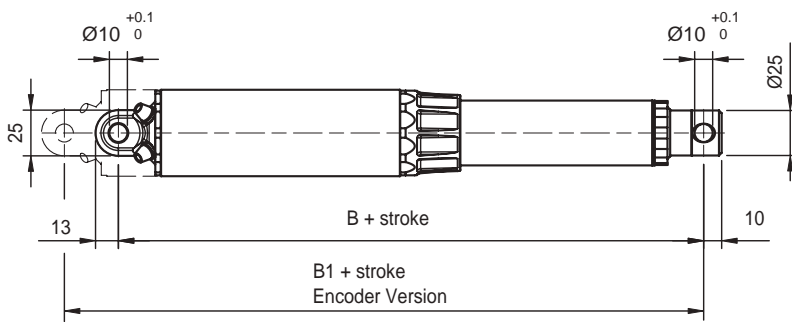
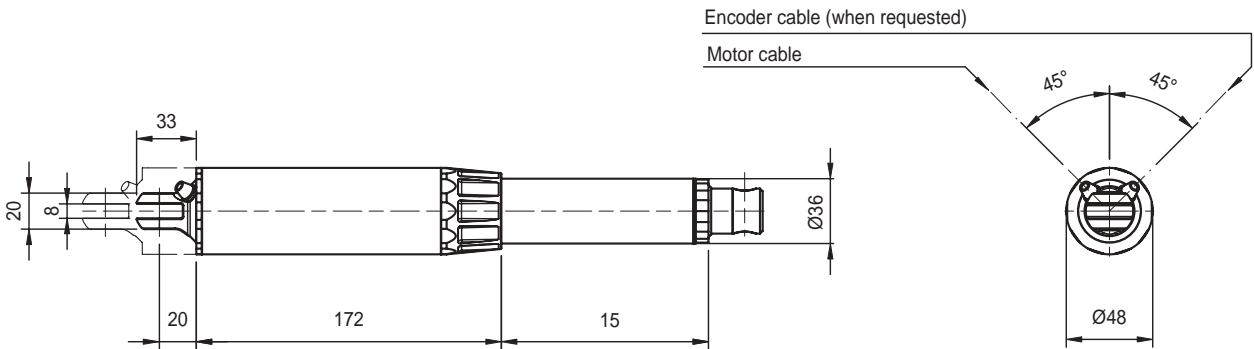

DIMENSION	Stroke < to 320 mm.	Stroke > to 320 mm.
B	228 + stroke	239 + stroke
B1	257 + stroke	268 + stroke

STROKE SETUP: Useful tips for handling stroke and avoid run-on-block collision.

When stroke is more than 350 mm, add 50 mm extra-stroke as guidance, and put corresponding value in ordering-key.

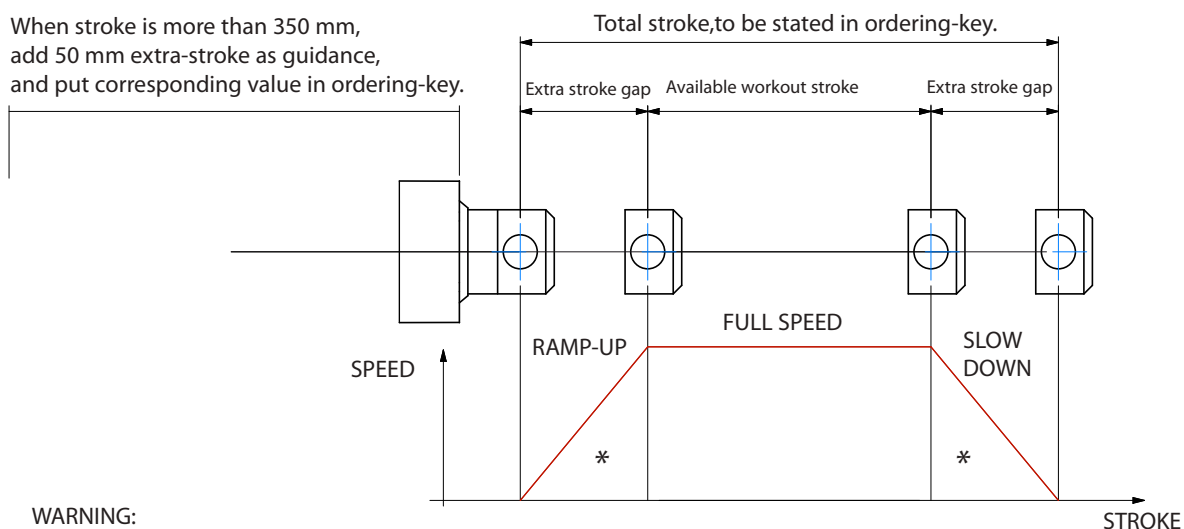

WARNING:
SPEED-TIMING ALONG STROKELENGTH:
 ramps are extremely important with high speed !!! Inverter or PWM drive recommended!
 * The more speed raises the more extra stroke has to raise too.

BUCKLING: When stroke is longer than 500mm, BUCKLING can be a risk: please check mounting with our offices and/or see user-manuals.

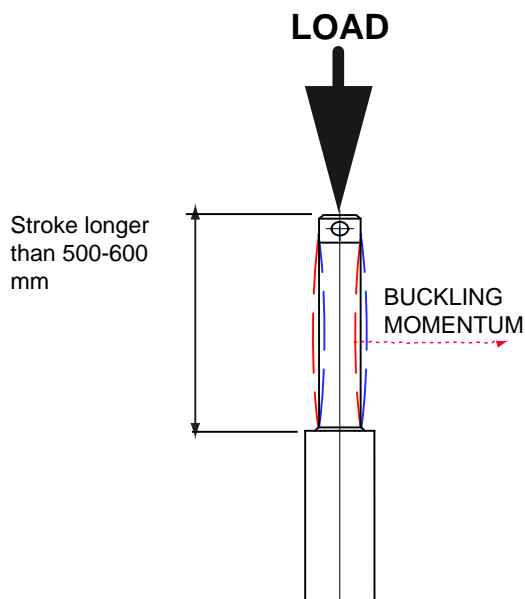

IMPORTANT:
 Long strokes, even if load is low, can generate significant buckling momentums, as sketch shows.
 This happens when actuator is in its all-opened position: that's the reason why we recommend 100 mm extra-stroke.
 Pushtube will have this 100 mm-portion always inside the overtube, improving guidance against buckling.
 For more information on this, contact our office.

ORDERING KEY

L02 / 0250 / M01 / 24 / 2FCM0 / E10 / P1 / A1

MODEL: _____
 L02 L02-FCM L02-VRS

STROKE: _____
 es. 250 mm = 0250
 min 50; with 50 as incremental

VERSION: (Pag. 57) _____
 M00 = Not standard speed

MOTOR: (Pag. ACCESSORIES) _____
 12 = 12 Vdc
 24 = 24 Vdc

LIMIT SWITCHES: (Pag. ACCESSORIES) _____
 None: Leave blank

ENCODER: (Pag. ACCESSORIES) _____
 E10: Encoder 1 channel 4 ppr NPN (open Collector)

REAR END: _____
 P1 = Yoke (standard)
 P2 = Special (provide drawing)

FRONT END: _____
 A1 = Eyelet (Std pag.58)
 A3 = Yoke + Clip
 A4 = Rod end
 A7 = M10 male

NOTE: COMPLETE THE ORDERING KEY ADDING THE OPTIONS YOU CAN FIND IN THE "ACCESSORIES AND OPTIONS" SECTION

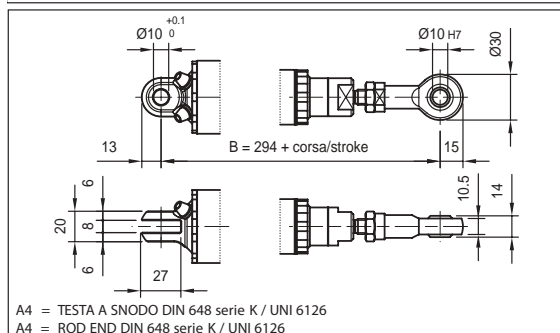
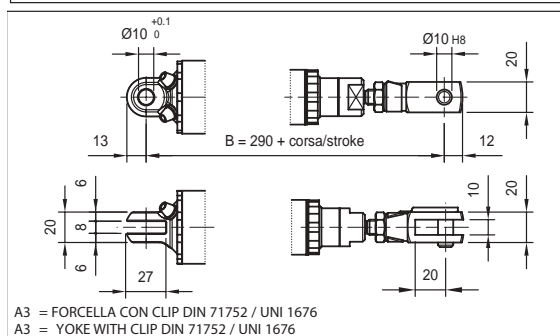
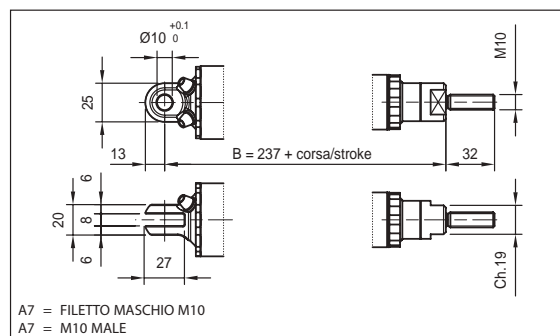
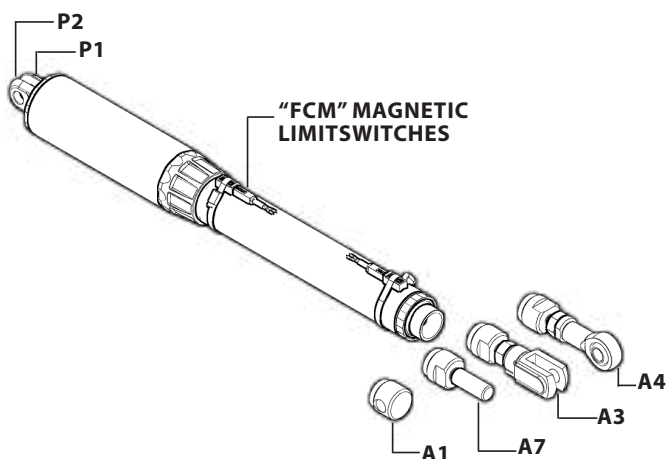

Note: "B" dimension changes according to model
Note: With encoder, dimension "B" is 30 mm longer
 L02 = See pictures
 L02 stroke > 320 mm = + 11 mm
 L02-FCM = + 34 mm
 L02-FCM stroke > 320 mm = + 45 mm
 with safety nut "G" = + 30 mm
 L02-VRS = + 40 mm
 Bellows + 20mm (no for versions FCM)

L03-Model C€

- Permanent magnet motor
- Planetary gearbox
- Acme lead screw or ballscrew (VRS)
- Chrome plated steel push rod
- Permanent grease lubrication
- IP 65, tested according to rule CEI EN 60529
- Working temperature range -10°C +60°C
- Intermittent duty S3 30% (5 min) a 30°C*
- Limit switches on request
- Encoder on request

(*) For any special duty please contact our technical dept.

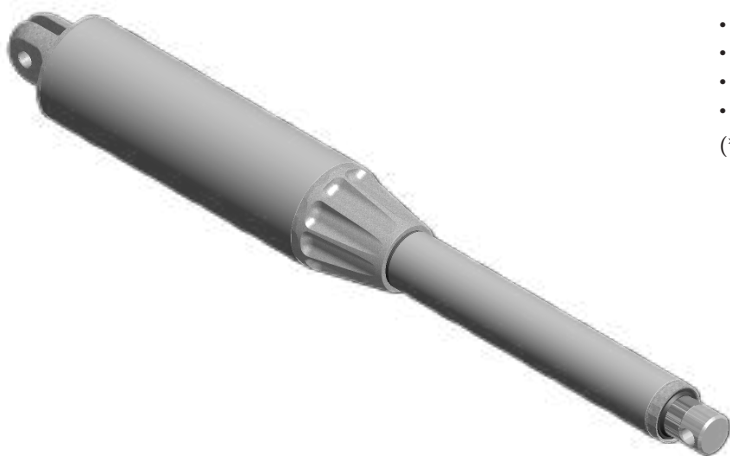

L03 (Vdc)						
<i>Fmax</i> (N)	<i>Speed</i> (mm/s)	<i>Version</i>	<i>Motor size</i>	<i>Motor power</i> (KW)	<i>Motor speed</i> (rpm)	<i>Max Current</i> <i>for F max(A)</i> 24Vdc
3000	20	M01	51	-	155	11
5000	10	M02	51	-	155	10
2000	30	M03	51	-	155	10,2

**

L03-VRS (Vdc) ballscrew						
<i>Fmax</i> (N)	<i>Speed</i> (mm/s)	<i>Version</i>	<i>Motor size</i>	<i>Motor power</i> (KW)	<i>Motor speed</i> (rpm)	<i>Max Current</i> <i>for F max(A)</i> 24Vdc
5000	13	M01	51	-	155	2,9

**

When strokes are longer than 350mm, check STROKE SETUP section.

** For 12 Vdc power supply currents are doubled and loads are 20% lower.

BEFORE OPERATING ACTUATOR MAKE SURE YOU READ AND UNDERSTOOD BASIC OPERATIONAL INSTRUCTIONS SHOWN ON USERMANUALS, AVAILABLE FROM WEBSITE.

THIS DOCUMENT DISPLAYS MOST TYPICAL STANDARD FEATURES AND SETUPS: CONTACT OUR OFFICES FOR MORE.

ACTUATOR SHALL NOT COME TO **MECHANICAL STROKE-END**, TO **AVOID FAILURES**.

CONSIDER MECVEL's LIMITSWITCHES (MODEL L03-F or L03-FCM) OR PUT THEM ON MACHINE/FRAME.



MecVel reserves the right to change products information and/or features without notice; all data contained in this catalogue are purely indicative and not binding for the company.

L03 Version without Limitswitches

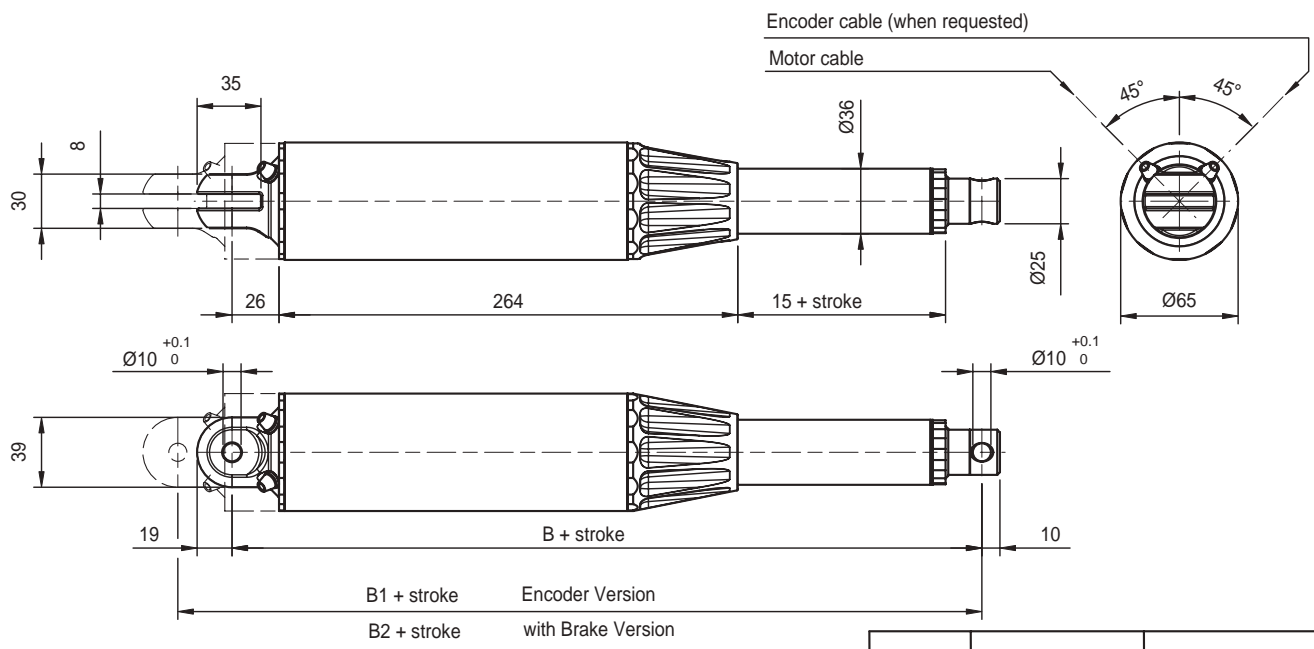

	DIMENSION	Stroke < to 320 mm.	Stroke > to 320 mm.
Version without Encoder and Brake	B	325 + stroke	336 + stroke
Version without Encoder	B1	355 + stroke	366 + stroke
Version without Brake	B2	355 + stroke	366 + stroke

For VRS and FCM versions see page 64.

VERSION WITH BRAKE IS not compatible with VERSION WITH ENCODER

STROKE SETUP: Useful tips for handling stroke and avoid run-on-block collision.

When stroke is more than 350 mm, add 50 mm extra-stroke as guidance, and put corresponding value in ordering-key.

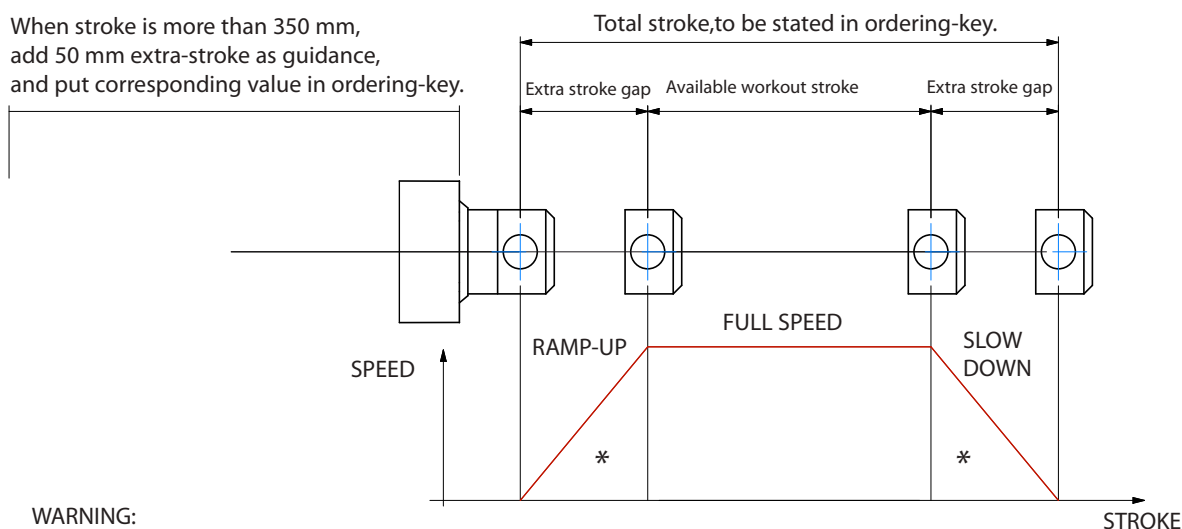

WARNING:
SPEED-TIMING ALONG STROKELENGTH:
 ramps are extremely important with high speed !!! Inverter or PWM drive recommended!
 * The more speed raises the more extra stroke has to raise too.

BUCKLING: When stroke is longer than 500mm, BUCKLING can be a risk: please check mounting with our offices and/or see user-manuals.

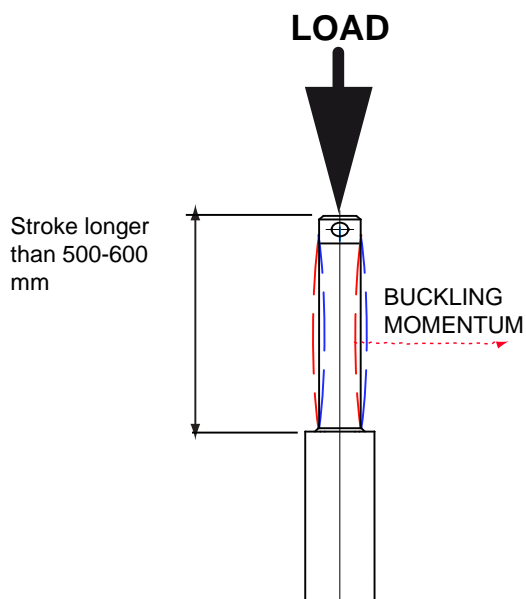

IMPORTANT:
 Long strokes, even if load is low, can generate significant buckling momentums, as sketch slows.
 This happens when actuator is in its all-opened position: that's the reason why we recommend 100 mm extra-stroke.
 Pushtube will have this 100 mm-portion always inside the overtube, improving guidance against buckling.
 For more information on this, contact our office.

L03 / 0250 / M01 / 24 / 2FCM0 / E10 / P1 / A1

MODEL: _____
 L03 L03-FCM L03-VRS

STROKE: _____
 es. 250 mm = 0250
 min 50; with 50 as incremental

VERSION: (Pag.61) _____
 M00 = Not standard speed

MOTOR: (Pag. ACCESSORIES) _____
12 = 12 Vcc
24 = 24 Vcc

LIMIT SWITCHES: (Pag. ACCESSORIES) _____
 None: Leave blank

ENCODER: (Pag. ACCESSORIES) _____
E50: Encoder 2 channel 4 ppr NPN (open Collector)

REAR END: _____
P1 = Yoke (standard)
P2 = Special (provide drawing)

FRONT END: _____
A1 = Eyelet (Std pag.62)
A3 = Yoke + Clip
A4 = Rod end
A7 = M10 male

NOTE: COMPLETE THE ORDERING KEY ADDING THE OPTIONS YOU CAN FIND IN THE "ACCESSORIES AND OPTIONS" SECTION

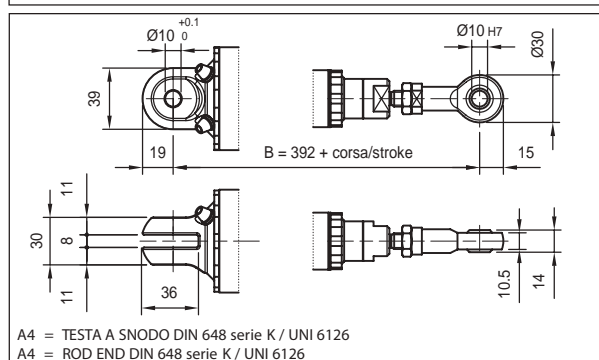
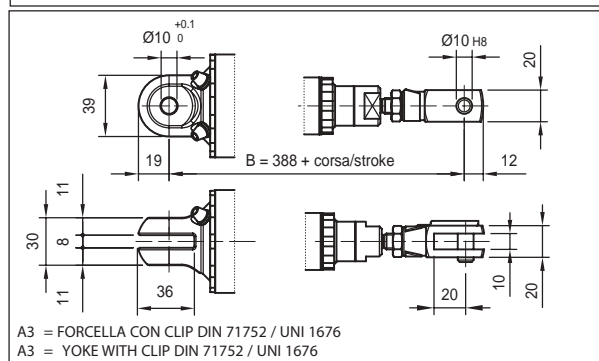
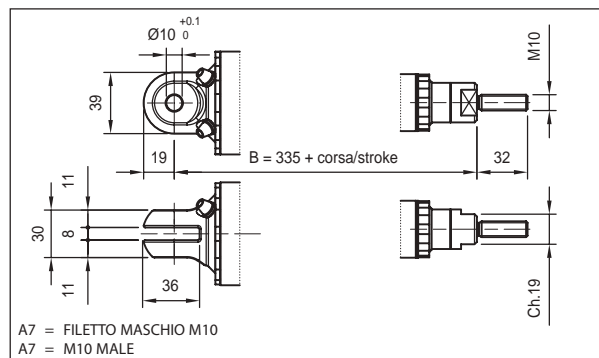
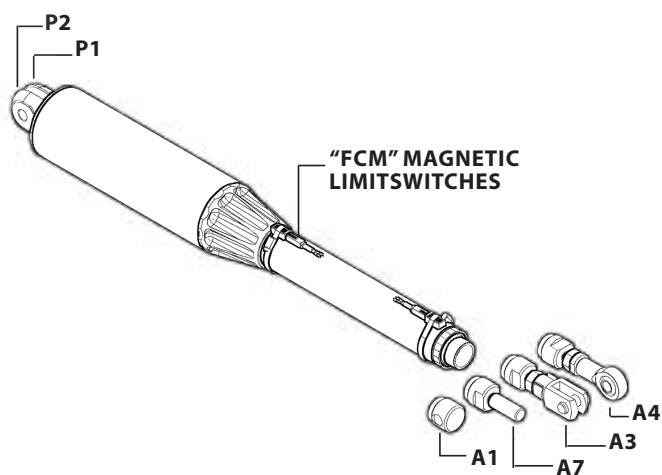

Note: "B" dimension changes according to model
Note: With encoder, dimension "B" is 30 mm longer
 L03 = See pictures - L03 stroke > 320 mm = + 11 mm
 L03-FCM = + 34 mm - L03-FCM stroke > 320 mm = + 44 mm
 with safety nut "G" = + 30mm
 L03-VRS = + 40 mm

EC1 - EC2 - EC3 - EC4 - EC5 Models CE

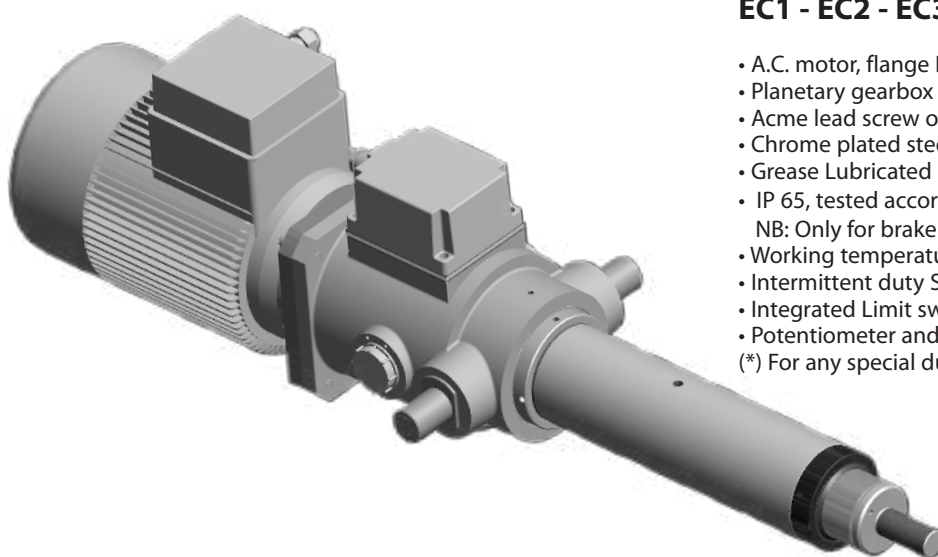

- A.C. motor, flange B14 - CE
- Planetary gearbox
- Acme lead screw or ballscrew (VRS)
- Chrome plated steel push rod
- Grease Lubricated
- IP 65, tested according to rule CEI EN 60529
- NB: Only for brake motors Standard IP54, IP65 on request
- Working temperature range -10°C +60°C
- Intermittent duty S3 30% (5 min) a 30°C*
- Integrated Limit switches for standard
- Potentiometer and encoder on request

(*) For any special duty please contact our technical dept.

EC1(Vac)					
Fmax (N)	Speed (mm/s)	Version	Motor size	Motor power (KW)	Motor speed (rpm)
* 500	193	M01	IEC63	0.37	2800
* 1250	97	M02	IEC71	0.37	1400
* 2000	60	M03	IEC71	0.37	900
5000	24	M04	IEC71	0.55	1400
5000	15	M05	IEC71	0.25	900
5000	6	M06	IEC63	0.13	1400

EC1 VRS (ballscrew) (Vac)					
Fmax (N)	Speed (mm/s)	Version	Motor size	Motor power (KW)	Motor speed (rpm)
* 500	230	M01	IEC63	0.18	2800
* 1250	115	M02	IEC63	0.18	1400
* 2000	75	M03	IEC71	0.25	900
5000	30	M04	IEC63	0.18	1400
5000	19	M05	IEC71	0.18	900
5000	7	M06	IEC63	0.13	1400

EC2 (Vac)					
Fmax (N)	Speed (mm/s)	Version	Motor size	Motor power (KW)	Motor speed (rpm)
* 1000	193	M01	IEC80	0.75	2800
* 2500	97	M02	IEC80	0.75	1400
* 2500	60	M03	IEC80	0.55	900
10000	24	M04	IEC80	1.1	1400
10000	15	M05	IEC80	0.55	900
10000	6	M06	IEC71	0.25	1400

EC2 VRS (ballscrew) (Vac)					
Fmax (N)	Speed (mm/s)	Version	Motor size	Motor power (KW)	Motor speed (rpm)
* 1250	230	M01	IEC71	0.37	1400
* 2500	150	M02	IEC80	0.55	900
* 5000	60	M03	IEC71	0.37	1400
10000	35	M04	IEC80	0.55	900
10000	15	M05	IEC63	0.18	1400

EC3 (Vac)					
Fmax (N)	Speed (mm/s)	Version	Motor size	Motor power (KW)	Motor speed (rpm)
* 2500	193	M01	IEC90	2.20	2800
* 5000	97	M02	IEC90	1.80	1400
* 5000	60	M03	IEC90	1.50	900
15000	24	M04	IEC90	1.80	1400
15000	15	M05	IEC90	1.10	900
15000	6	M06	IEC71	0.37	1400

EC3 VRS (ballscrew) (Vac)					
Fmax (N)	Speed (mm/s)	Version	Motor size	Motor power (KW)	Motor speed (rpm)
* 3000	230	M01	IEC80	0.75	1400
* 3000	150	M02	IEC80	0.55	900
* 10000	60	M03	IEC80	0.75	1400
15000	35	M04	IEC80	0.55	900
15000	15	M05	IEC71	0.25	1400

EC4 (Vac)					
Fmax (N)	Speed (mm/s)	Version	Motor size	Motor power (KW)	Motor speed (rpm)
* 15000	56	M01	IEC112	2.20	900
* 25000	42	M02	IEC100	4.00	1400
30000	25	M03	IEC112	3.00	900
30000	10	M04	IEC90	1.50	1400

EC4 VRS (ballscrew) (Vac)					
Fmax (N)	Speed (mm/s)	Version	Motor size	Motor power (KW)	Motor speed (rpm)
* 25000	60	M01	IEC90	1.80	1400
30000	35	M02	IEC100	1.50	900
30000	15	M03	IEC90	1.10	1400

EC5 (Vac)					
Fmax (N)	Speed (mm/s)	Version	Motor size	Motor power (KW)	Motor speed (rpm)
50000	11	M01	IEC100	3.00	1400
50000	7	M02	IEC100	2.20	900

EC5 VRS (ballscrew) (Vac)					
Fmax (N)	Speed (mm/s)	Version	Motor size	Motor power (KW)	Motor speed (rpm)
50000	15	M01	IEC90	1.10	1400
50000	10	M02	IEC90	0.75	900

With single-phase motors type M (see motor choice guideline in paragraph ACCESSORIES) performances are 20% lower than the three-phase motor.

- * When speed is more than 40 mm/s and/or strokes longer than 350mm, check STROKE SETUP section; BRAKEMOTOR IS RECOMMENDED BEFORE OPERATING ACTUATOR MAKE SURE YOU READ AND UNDERSTOOD BASIC OPERATIONAL INSTRUCTIONS SHOWN ON USERMANUALS, AVAILABLE FROM WEBSITE.

THIS DOCUMENT DISPLAYS MOST TYPICAL STANDARD FEATURES AND SETUPS: CONTACT OUR OFFICES FOR MORE.

ACTUATOR SHALL NOT COME TO **MECHANICAL STROKE-END**, TO **AVOID FAILURES**.

CONSIDER MECVEL's LIMITSWITCHES (MODEL EC or EC-F) OR PUT THEM ON MACHINE/FRAME.



MecVel reserves the right to change products information and/or features without notice; all data contained in this catalogue are purely indicative and not binding for the company.

EC1 / 2 / 3

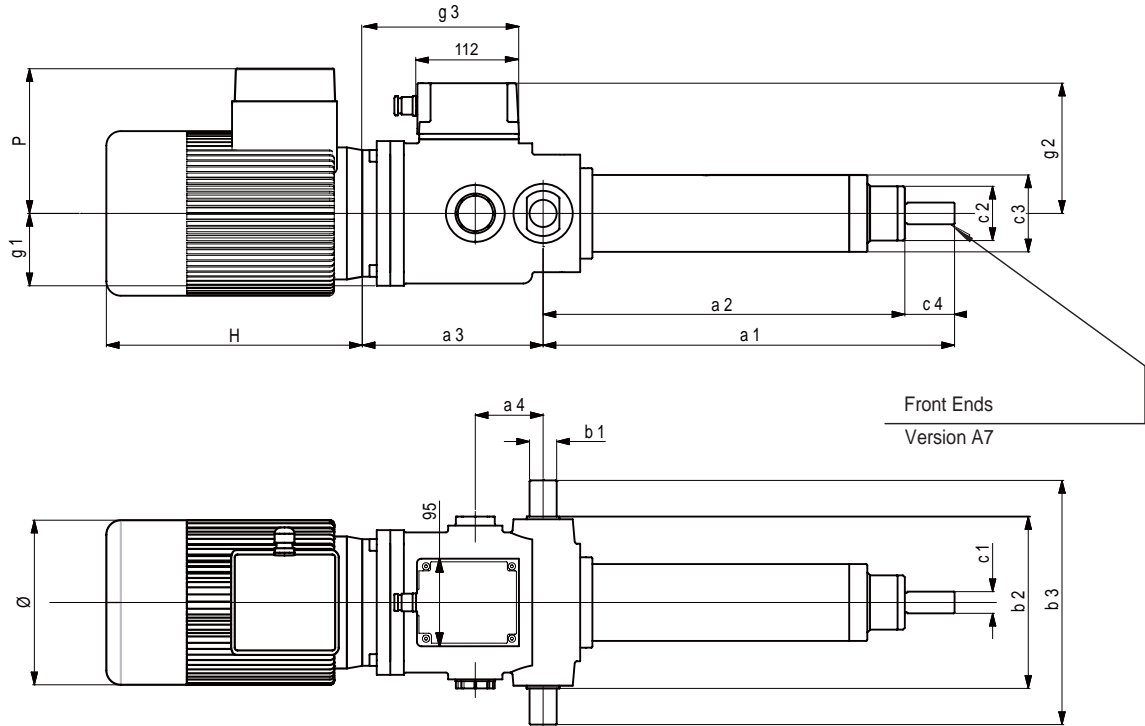

SIZE	DIMENSIONS TABLE													
	1) a1	1) a2	2) a3	a4	(Øh7) b1	b2	b3	c1	c2	c3	c4	g1	g2	2) g3
1	145	111	*	61	Ø14	105	145	M10	Ø30	Ø50	34	50	103	*
2	167	123	*	66	Ø20	140	200	M12	Ø50	Ø70	44	65	118	*
3	255	200	*	75	Ø30	190	270	M18	Ø60	Ø85	55	80	138	*

SIZE	BALLSCREW DIMENSIONS TABLE													
	1) a1	1) a2	2) a3	a4	(Øh7) b1	b2	b3	c1	c2	c3	c4	g1	g2	2) g3
1	169	135	*	61	Ø14	105	145	M10	Ø30	Ø50	30	50	103	*
2	233	189	*	66	Ø20	140	200	M12	Ø50	Ø70	35	65	118	*
3	317	262	*	75	Ø30	190	270	M18	Ø60	Ø85	45	80	138	*

- 1) Dimensions are valid for stroke = 0, for the exact overall dimension add the wanted stroke in mm.
- 2) Dimensions change according to actuator model. See charts sideways.

A.C. MOTORS DIMENSIONS				
SIZE	VERSIONE / TYPE	H	Ø	P
63	Standard	185	123	110
	Brake motors	234		
71	Standard	215	140	121
	Brake motors	267		
80	Standard	238	159	138
	Brake motors	296		
90	Standard	255	176	149
	Brake motors	319		

EC1		Version					
		M01	M02	M03	M04	M05	M06
	a3	147	157	157	157	157	172
g3	131	141	141	141	141	156	

EC1-VRS		Version					
		M01	M02	M03	M04	M05	M06
	a3	147	147	157	147	157	172
g3	131	131	141	131	141	156	

EC2		Version					
		M01	M02	M03	M04	M05	M06
	a3	182	182	182	182	182	201
g3	158	158	158	158	158	177	

EC2-VRS		Version				
		M01	M02	M03	M04	M05
	a3	169	182	169	182	201
g3	145	158	145	158	177	

EC3		Version					
		M01	M02	M03	M04	M05	M06
	a3	200	200	200	200	200	226
g3	173	173	173	173	173	199	

EC3-VRS		Version				
		M01	M02	M03	M04	M05
	a3	188	188	188	188	226
g3	161	161	161	161	199	

EC4 / 5

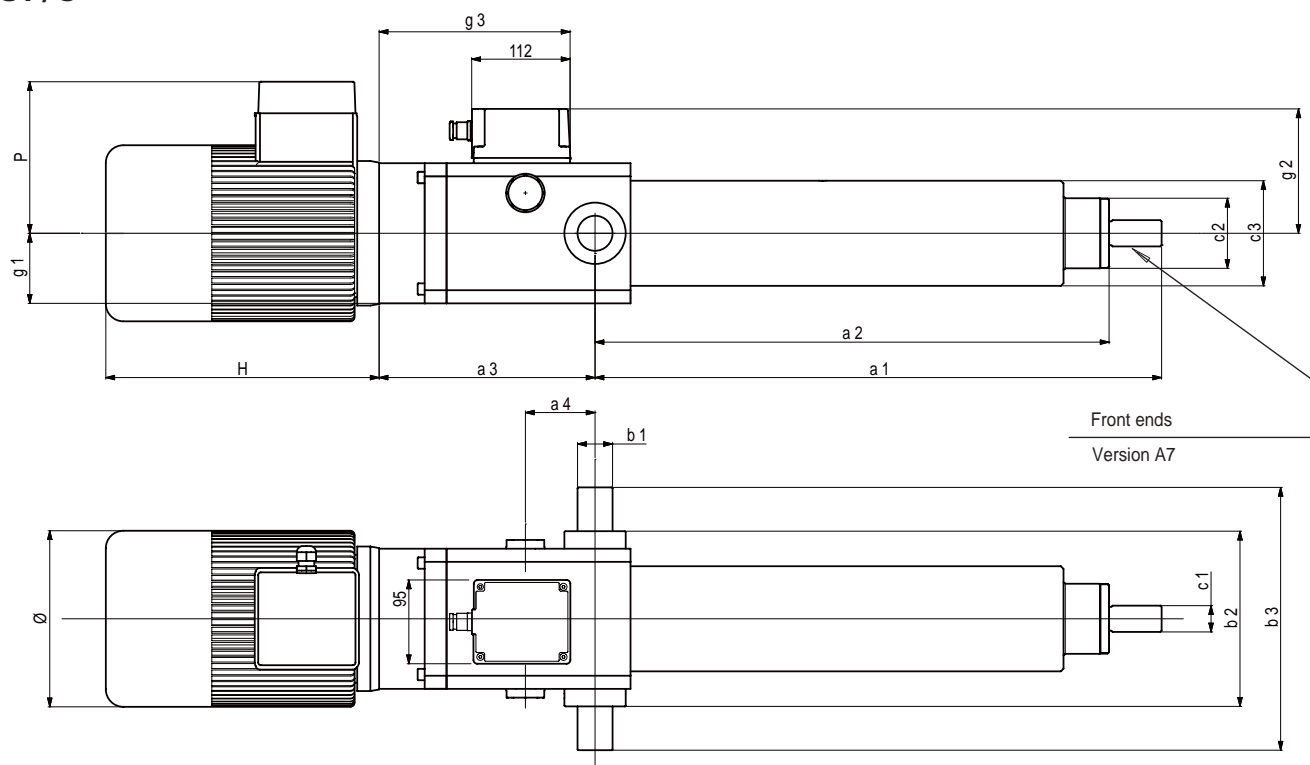

SIZE	DIMENSIONS TABLE													
	1)	1)	2)		Øh7								2)	
	a1	a2	a3	a4	b1	b2	b3	c1	c2	c3	c4	g1	g2	g3
4	272	212	*	79.5	40	200	300	M30x2	80	120	60	80	136	*
5	272	212	*	79.5	40	200	300	M30x2	80	120	60	80	136	*

SIZE	BALLSCREW DIMENSIONS TABLE													
	1)	1)	2)		Øh7								2)	
	a1	a2	a3	a4	b1	b2	b3	c1	c2	c3	c4	g1	g2	g3
4	318	259	*	79.5	40	200	300	M30x2	80	120	60	80	136	*
5	318	259	*	79.5	40	200	300	M30x2	80	120	60	80	136	*

1) Dimensions are valid for stroke = 0, for the exact overall dimension add the wanted stroke in mm.

2) Dimensions change according to actuator model. See charts sideways.

A.C. MOTORS DIMENSIONS				
SIZE	TYPE	H	Ø	P
90	Standard	255	176	149
	Brake motors	319		
100	Standard	309	195	173
	Brake motors	374		
112	Standard	328	219	192
	Brake motors	407		

EC4	Version			
	M01	M02	M03	M04
	a3	246.5	246.5	246.5
g3	218	218	218	210

EC4-VRS	Version		
	M01	M02	M03
	a3	200.5	246.5
g3	172	218	210

EC5	Version	
	M01	M02
	a3	284.5
g3	256	256

EC5-VRS	Version	
	M01	M02
	a3	238.5
g3	210	210

Front ends

A3 = YOKE WITH CLIP DIN 71752 / UNI 1676

SIZE	DIMENSIONS TABLE									
	a1	a1 VRS (BALLSCREW)	a2	a3	a4	a5	a6	a8	a9	a10
1	172	196	14	Ø12	M12	12	61	24	24	24
2	220	286	25	Ø20	M20x1,5	20	97	40	40	40
3	317	379	35	Ø25	M24x2	25	117	50	50	50
4 / 5	345	392	38	Ø30	M27x2	30	131	54	55	55

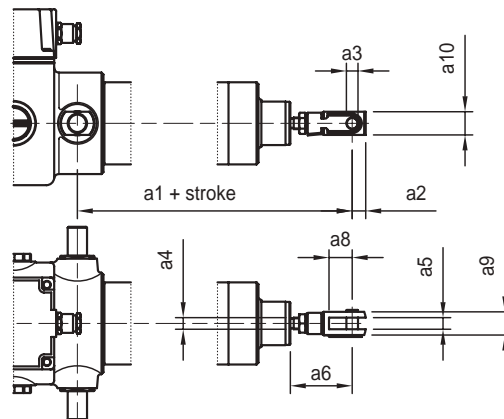

A4 = ROD END DIN 648 serie K / UNI 6126

SIZE	DIMENSIONS TABLE								
	b1	b1 VRS (BALLSCREW)	b2	b3 (ØH7)	b4	b5	b6	b7	b9
1	174	198	16	Ø12	M12	12	16	63	32
2	217	283	25	Ø20	M20x1,5	18	25	94	50
3	313	375	30	Ø25	M24x2	22	31	113	60
4 / 5	345	392	35	Ø30	M27x2	25	37	131	70

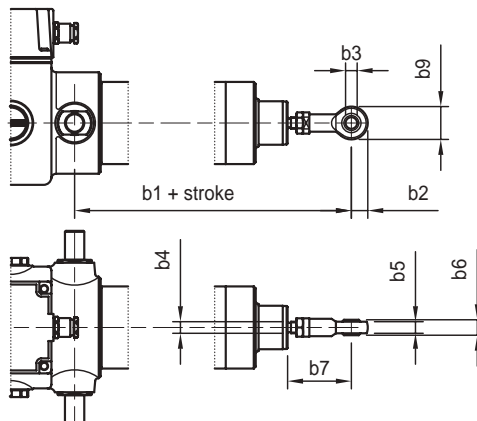

Bellows = +25 mm

STROKE SETUP: Useful tips for handling stroke and avoid run-on-block collision.

When stroke is more than 350 mm, add 50 mm extra-stroke as guidance, and put corresponding value in ordering-key.

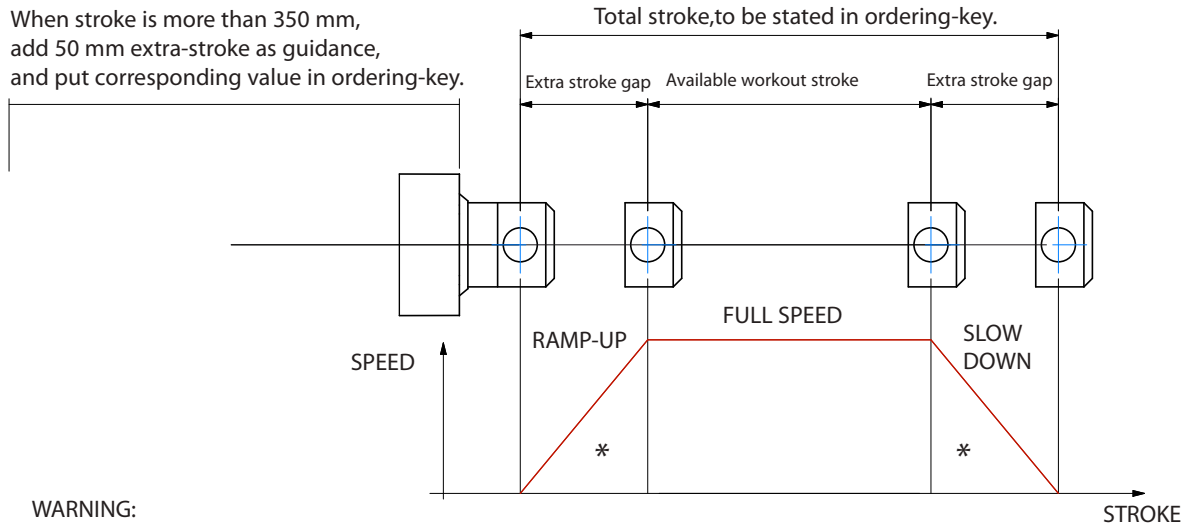

WARNING:
SPEED-TIMING ALONG STROKELENGTH:
 ramps are extremely important when speed is > 40mm/s !!! Inverter or PWM drive recommended!
 * The more speed raises the more extra stroke has to raise too.

BUCKLING: When stroke is longer than 500mm, BUCKLING can be a risk: please check mounting with our offices and/or see user-manuals.

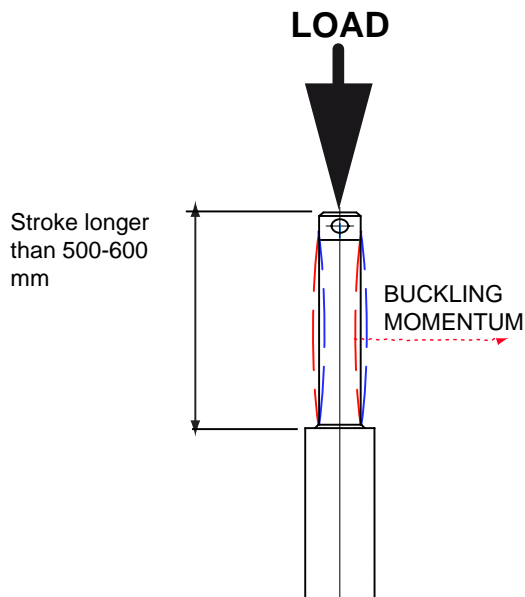

IMPORTANT:
 Long strokes, even if load is low, can generate significant buckling momentums, as sketch slows.
 This happens when actuator is in its all-opened position: that's the reason why we recommend 100 mm extra-stroke.
 Pushtube will have this 100 mm-portion always inside the overtube, improving guidance against buckling.
 For more information on this, contact our office.

ORDERING KEY

EC1 / 0250 / M01 / CA-400-50-T-56-4-0,09 / AB / E05 / 2FC2 / POT01A / A3

MODEL: _____

EC1 / EC2 / EC3 / EC4 / EC5
 EC1-VRS / EC2-VRS / EC3-VRS / EC4-VRS
 EC5-VRS

STROKE: _____

es. 250 mm = 0250

VERSION: (Pag. 65) _____

Advise: choose among
 M00 = Not standard speed
 Flanged Version:
 Advise reduction ratio and screw pitch

MOTOR: (Pag. ACCESSORIES) _____

Advise only if with motor:
 version, voltage, type, size, n°pole, power
 With motorflange only put 0
 With special motorflange put: PD

AC MOTOR OPTIONS: (Pag. ACCESSORIES) _____

Motorflange: for motorflange version only advise size - i.e.for IEC80 B14 put 80B14
 No motor: leave all following parameters blank
 Protection Degree: IP65, for selfbrake motor IP54 standard
 Brake type: for brakemotors only: ES. FECA
 Options: Advise if needed (ES. AB 2'shaft)

ENCODER: (Pag. ACCESSORIES) _____

None: Leave blank

LIMIT SWITCHES: (Pag. ACCESSORIES) _____

None: Leave blank

POTENTIOMETER: (Pag. ACCESSORIES) _____

POT01A (1Kohm) POT10A (10Kohm) None: Leave blank

FRONT END: _____

A3 = Yoke + Clip A4 = Rod end A7 = Male threaded pin

NOTE: COMPLETE THE ORDERING KEY ADDING THE OPTIONS YOU CAN FIND IN THE "ACCESSORIES AND OPTIONS" SECTION

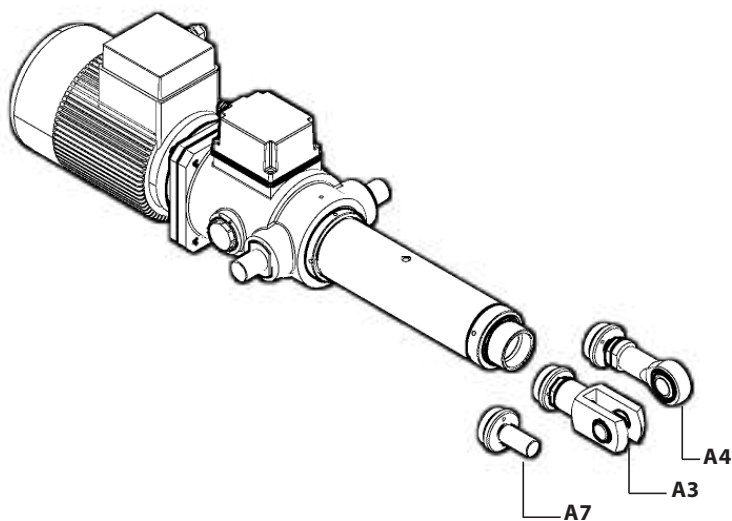

ACCESSORIES AND OPTIONS



OPTIONS:

A	= Stainless steel version (pag. 89)
AA	= Industry version (pag. 90)
B	= Bellows boot (pag. 87)
CG	= Bellflange with coupling (on request)
E	= Viton seals (pag. 89)
FX	= Anticorrosion painting (pag. 90)
FXC	= Cataphoresis (pag. 90)
G	= Safety nut (pag. 87)
H	= Handwheel (pag. 88)
L	= Anti rotation device (pag. 85)
MM	= Manual driving for ALI1 and ALI1-P models (pag.89)
N	= Manual driving with safety limit switch (pag.88)
O	= Body integrated Swivelling shafts (on request)
OA	= Front Swivelling plate (on request)
OP	= Rear Swivelling plate (on request)
P	= Handwheel and safety-switch (pag. 88)
PO	= Rear-pipe for swinging movement (on request)
S	= Torque limiter (pag.85)
T	= Additional shaft (pag.86)
Z	= Low noise (pag. 89)

N. DIS. = Drawing number: Request of no standard options.

ACCORDING TO THE OPTIONS DESIRED, ADD THE IDENTIFICATION LETTERS AT THE END OF THE ORDERING KEY RELATED TO THE PRODUCT CHOSEN

Examples:

ALIS / 0300 / M01 / CA-400-50-T-71-2-0,55 / B5+AB / M1-FC1 / 1 / E05 / 2FC0 / POT01A / P1 / A1























Ordering key for
standard product

ALIS / 0300 / M01 / CA-400-50-T-71-2-0,55 / B5+AB / M1-FC1 / 1 / E05 / 2FC0 / POT01A / P1 / A1 + AA + S + T

Ordering key for
standard product + options















ALIS / 0300 / M01 / CA-400-50-T-71-2-0,55 / B5+AB / M1-FC1 / 1 / E05 / 2FC0 / POT01A / P1 / A1 / S + T / N.DIS

Ordering key with NO
standard options

OPTION / ACCESSORY	POWER SUPPLY		PROTECTION CLASS		LIMIT SWITCHES	POTENTIOMETER	ENCODER	ANTIROTATION "L"	TORQUE LIMITER "S"	ADDITIONAL SHAFT "T"	SAFETY NUT "G"
	DC	AC	IP 54	IP 65							
See page	74		76		77	82	83	85	85	86	87
MODEL	DC	AC	IP 54	IP 65							
ALI1 	●	/	/	●	○	/	○	○	/	/	/
ALI1-F 	●	/	/	●	●	/	○	○	/	/	/
ALI1-P 	●	/	/	●	○	/	○	○	/	/	/
ALI1-PF 	●	/	/	●	●	/	○	○	/	/	/
ALI2 	●	●	● AC	● DC AC	○	/	○	○	○	/	○
ALI2-F 	●	●	● DC	● DC AC	●	○	○	○	○	/	○
ALI2-P 	●	/	/	●	○	/	○	○	/	/	○
ALI2-PF 	●	/	/	●	●	○	○	○	/	/	○
ALI3 	●	●	● AC	● DC AC	○	/	○	○	/	/	○
ALI3-F 	●	●	● AC	● DC AC	●	○	○	○	/	/	○
ALI3-P 	●	/	/	●	○	/	○	○	/	/	○
ALI3-PF 	●	/	/	●	●	○	○	○	/	/	○
ALI4 	●	●	●	○	○	/	○	○	○	○	○
ALI4-F 	●	●	●	○	●	○	○	○	○	○	○
ALI5 	/	●	●	○	○	/	○	○	○	○	○
ALI5-F 	/	●	●	○	●	○	○	○	○	○	○
ALI5-P 	/	●	●	○	○	/	○	○	○	/	○
AV3 	/	●	●	○	●	○	○	○	○	/	○
ECV9092 	/	●	●	○	●	○	○	○	○	/	○
L02 	●	/	/	●	○	/	○	○	/	/	○
L03 	●	/	/	●	○	/	○	○	/	/	○
EC 	/	●	●	○	●	○	○	○	/	○	○

● SERIES / NOT AVAILABLE ○ ON REQUEST

ACCESSORIES AND OPTIONS

OPTION / ACCESSORY	BELLEWS BOOT "B"	MANUAL DRIVING "H" "N" "P" "MM"	VITON SEALS "E"	STAINLESS STEEL "A"	LOW NOISE "Z"	PROTECTIVE PAINTING "FX" "FXC"	INDUSTRY VERSION "AA"	ELECTRONIC DEVICES	SWIVELLING SHAFTS HOLDER	REAR BRACKET
see page	87	88-89	89	89	89	90	90	91	96	98
MODEL										
ALI1 	/	Without Handwheel	/	○	/	○	/	○	/	/
ALI1-F	/		/	○	/	○	/	○	/	/
ALI1-P 	/	Without Handwheel	/	○	/	○	/	○	/	/
ALI1-PF	/		/	○	/	○	/	○	/	/
ALI2 	○	○ AC	○	○	○	○	/	○	/	○
ALI2-F	○	○ AC	○	○	○	○	/	○	/	○
ALI2-P 	○	/	○	○	○	○	/	○	/	○
ALI2-PF	○	/	○	○	○	○	/	○	/	○
ALI3 	○	○ AC	○	○	○	○	/	○	/	○
ALI3-F	○	○ AC	○	○	○	○	/	○	/	○
ALI3-P 	○	/	○	○	○	○	/	○	/	○
ALI3-PF	○	/	○	○	○	○	/	○	/	○
ALI4 	○	○	○	○	○	○	/	○	/	○
ALI4-F	○	○	○	○	○	○	/	○	/	○
ALI5 	○	○	○	○	/	○	○	○	/	○
ALI5-F	○	○	○	○	/	○	○	○	/	○
ALI5-P 	○	○	○	○	/	○	/	○	/	○
AV3 	○	○	○	○	/	○	○	○	/	/
ECV9092 	○	○	○	○	/	○	○	○	/	/
L02 	○	/	○	○	/	○	/	○	/	○
L03 	○	/	○	○	/	○	/	○	/	○
EC 	○	○	○	○	/	○	○	○	○	/



SERIES



NOT AVAILABLE



ON REQUEST

Motor choice guideline

MOTOR TYPE

Version:	DC = direct current AC = alternate current PD = Special motorflange (provide drawing)
Voltage:	DC = V12 / V24 AC = Standard voltage table MT = Multivoltage
Type: (only for AC)	T = 3-phase M = 1-phase AT = 3-phase with brake AM = 1-phase with brake
Size:	AC: IEC 50/56/63/71/80/90/100/112/132
Pole:	AC: 2 / 4 / 6

Standard voltage table		
[V] [Hz] Rated Voltage:		[V] [Hz] Usable voltages
230/400/50	277/480/60	240/415/50 - 220/380/50 - 265/460/60 - 255/440/60
190/330/50	220/380/60	200/346/60 - 208/360/60 - 230/400/60
208/360/50	254/440/60	200/346/50 - 240/415/60
400/690/50	480/830/60	380/660/50 - 415/717/50

AC MOTOR OPTIONS

Motorflange type:	IEC56B14 / IEC63B14 / IEC71B14 / IEC80 B14 / IEC90 B14 / IEC100/112 B14
Service rate:	S3 30%
Insulation class:	F = standard (leave blank) Advise only if different than "F"
Protection Degree:	IP54 (leave blank) IP65 TP = tropicalization OTHER = advise NONE = leave blank

Motor connections

3-phase motor

3-phase motor 2 speed

1-phase motor

1-phase motor balanced winding

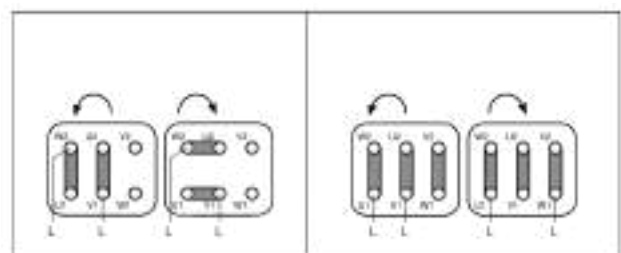
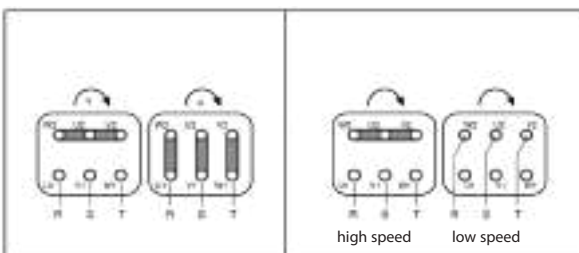

ACCESSORIES AND OPTIONS

Brake:

FECC DC brake negative action (standard)

Power Supply

230V±10% 50/60Hz AC side inside the brake. The brake is powered directly from the power supply of the motor (standard)

Motors with separated brake power supply and tensions in the range (24-205 Vdc) can be available on request.

In this case the brake needs a separated power supply from the motor and its code becomes FECC-AS-24 Vdc

FECA= AC brake

Power Supply

230/400V±10% 50/60Hz. The brake is powered directly from the power supply of the motor.

Motors with separated brake power supply and tensions in the range (24-690 Vac - 50/60 Hz) can be available on request.

In this case the brake needs a separated power supply from the motor and its code becomes FECA-AS-230 Vac 50 HZ

Separate brake power supply:

Achieved by means of an auxiliary terminal board, with fixed brake coil terminals, located inside the motor terminal box

Nb: On all motors equipped with inverters the brake must always have a separate power supply.

NO BRAKE = leave blank

Options:

LS = hand release lever (leave blank)

NOTE: not available for motor IEC 50 IEC 56















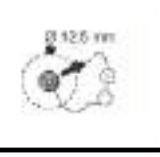

AB = 2'shaft

OTHER = advise

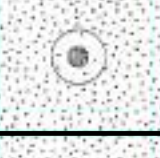
NONE = leave blank

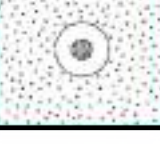
HOUSING PROTECTION LEVEL (IPCode)

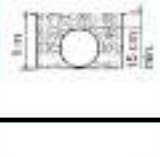
Example: IP65

First digit Protection against solid objects			Second digit Protection against liquids		
0		Not protected	0		Not protected
1		Protected against solid foreign objects of 50 mm diameter and greater	1		Protected against vertically falling water drips
2		Protected against solid foreign objects of 12,5 mm diameter and greater	2		Protected against vertical water drips with casing inclined up to 15°
3		Protected against solid foreign objects of 2,5 mm diameter and greater	3		Protected against spraying water
4		Protected against solid foreign objects of 1,0 mm diameter and greater	4		Protected against splashing water
5		Protected against dust	5		Protected against jets of water
6		Totally protected against dust	6		Protected against powerful jets of water jets
			7		Protected against the effects of temporary immersion in water
			8		Protected against the effects of continuous immersion in water

The tables shown in this page are from IEC EN 60529 (CEI 70-1) standards

MecVel standard products are equipped with IP54 or IP65

ACCESSORIES AND OPTIONS

Electric / Electronic Stroke Control Devices

Actuators can host different stroke control systems: simple micro-switches (mechanical or magnetic) able to provide a signal to handle motor supply (ON-OFF operation), or electronic devices for servo-mechanisms.

 All wiring operations of actuator (motor and stroke control devices) must be done with power switched off. If not, both operator and actuator are at risk.

LIMIT SWITCHES INTEGRATED IN TO COVERTUBE (ONLY FOR ALI1 AND ALI1-P MODEL)

This model is equipped with two limit switches (featuring one contact each). A version with a third limit switch, central positioning, is available.

Intermediate position changes according to push-rod moving direction. Tuning is adjusted by turning screws on actuator header. Each clock wise turn of the screw allows the micro switch to go 0.7 mm. forth, towards the header itself.

Look at the drawing to see how it works; letters have following meaning:

A-F = Front I = Intermediate P-B = Back

Minimum stroke setting

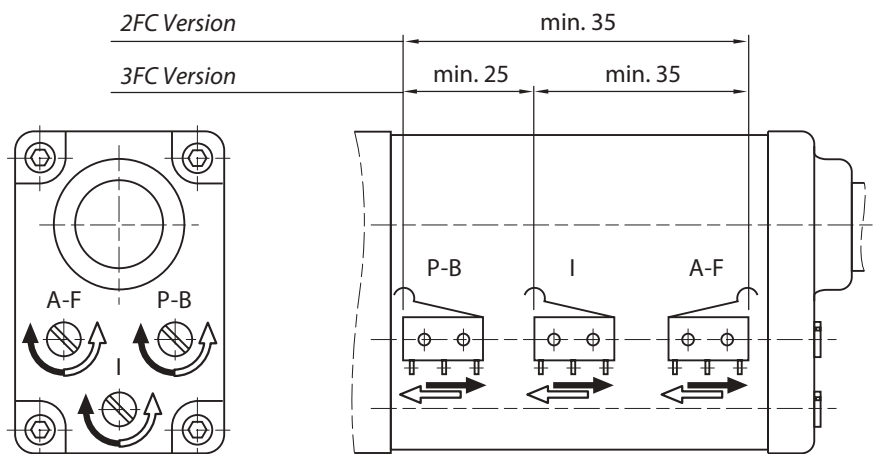

Vac Max. El. Ratings		
Voltage Vac	Resistive load A	Inductive load A
125	5	2
250	5	2

Vdc Max. El. Ratings		
Voltage Vdc (up to)	Resistive load A	Inductive load A
30	5	3
50	1	1

Limit Switches Features

- Housing: Glass fibre reinforce PA66
- Mechanism: Snap-action coil spring mechanism with stainless steel spring. Change over, normally-closed / normally-open

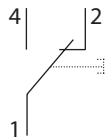

- Mechanical life: 5x10⁶ cycle minimum (impact free actuation)

INTEGRATED MECHANICAL LIMIT SWITCHES

Changeover single-contact, cam-actuated micro-switches integrated onto actuator gearbox, getting movement by a small gearing connected to lead screw.

System is thus protected and compact but its limit lies in long strokes: since the stroke is directly related to cams angle of rotation, with long strokes this device is not able to perform.

Furthermore its stopping precision and repeatability are negatively affected by actuator non-self locking condition.

A potentiometer is also available for some of the gearbox ratios (hence speeds) and limited lengths of the stroke to be controlled.



In case integrated mechanical limit switches are delivered already adjusted, manual rotation of push-rod will cause adjustment loss!



Running against mechanical stop causes serious damages to actuator's mechanical stroke limit device!

Limit switches		
Performance	XCF Type	XGG Type (on request)
Voltage	250 Vac	230 Vac / 30 Vdc
Resistive load	10 A	16 A
Motor load	2 A	6 A

Limit Switches technical features

- Housing: Phenolic-melamine thermosetting
- Mechanism: Snap-action coil spring mechanism with beryllium / bronze spring.
Changeover contact, normally-closed / normally-open.

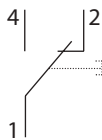

- Contacts: fine silver
- Terminals: gold flashed
- Mechanical life: 3×10^5 (XGG) cycles minimum (impact free actuation).

ORDERING KEY REFERENCES

Mechanical limit switches:

2FC1 = 2 Microswitches XCF (standard version)

3FC1 = 3 Microswitches XCF (standard version)

2FC2 = 2 Micro XGG

3FC2 = 3 Micro XGG

2FCD1 = 2 XCF Microswitches diode-wired

3FCD1 = 3 XCF Microswitches, 2 of them diode-wired

2FCD2 = 2 XGG Microswitches diode-wired

3FCD2 = 3 XGG Microswitches, 2 of them diode-wired

(for DC motor only and for loads up to 10A)

ACCESSORIES AND OPTIONS

2FC1

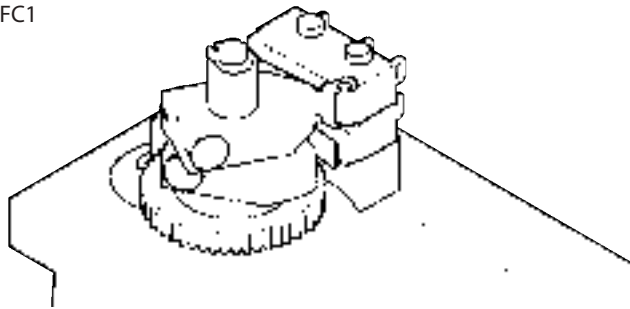

3FC1

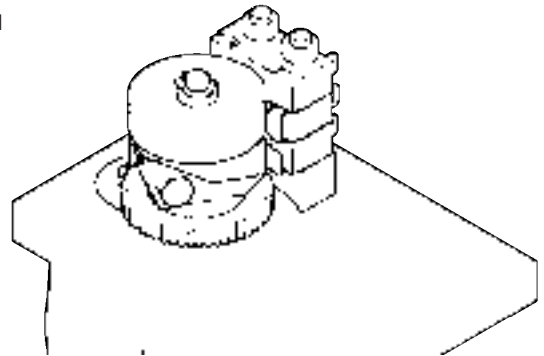

2FCD

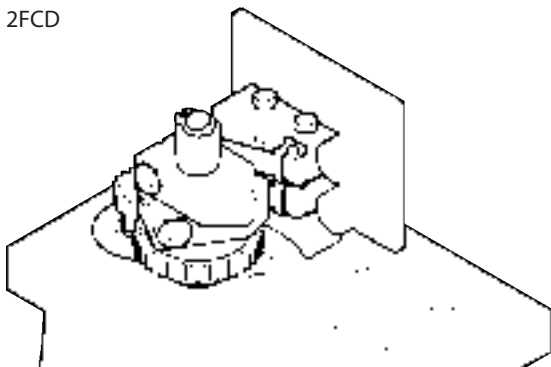

3FCD

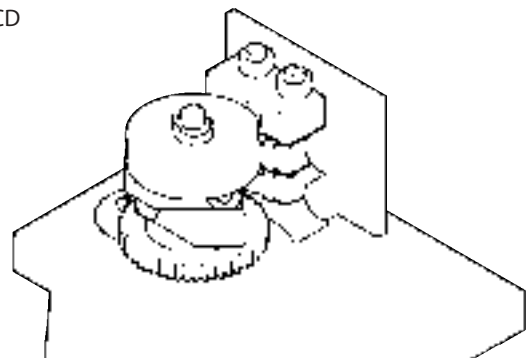

2FC2

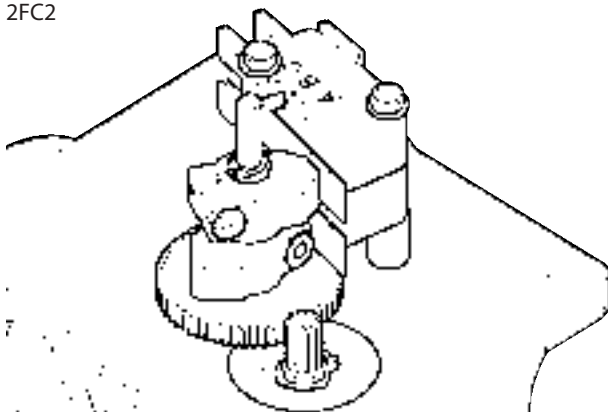

3FC2

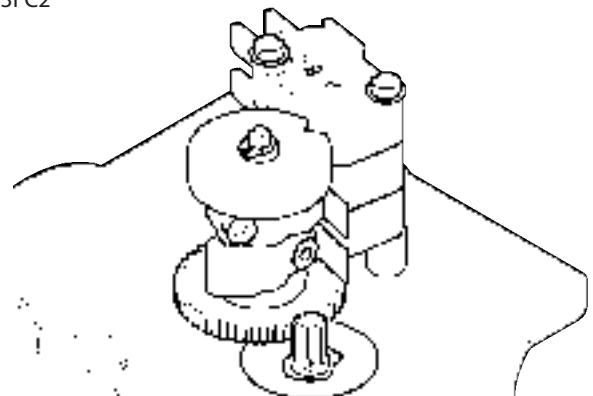

2FC1/ 3FC1 Available on ALI2 ALI2-P ALI3 ALI3-P

2FCD/ 3 FCD Available on ALI2 ALI2-P ALI3 ALI3-P ALI4, with 10A max consumption.

2FC2/ 3FC2 Available on ALI4 e ALI5; standard on AV3 ECV9092 EC

Inductive sensors FCI

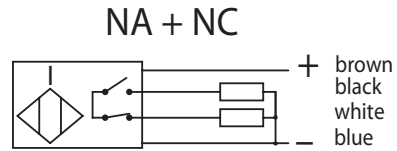
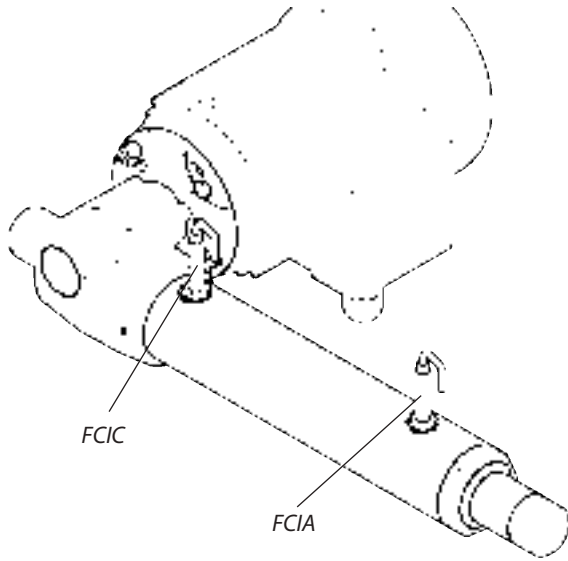

FCIC = All-closed inductive switch

FCIA = All-opened inductive switch

FCI Inductive Limit switches	
DC voltage	5 ÷ 40 Vdc
Temperature range	25° ÷ 75°
Protection Level	IP67
Switch status indicator	YELLOW LED

ORDERING KEY REFERENCES

Inductive sensors:

2FCI = 2 Sensors NO + NC

FCI POSITION

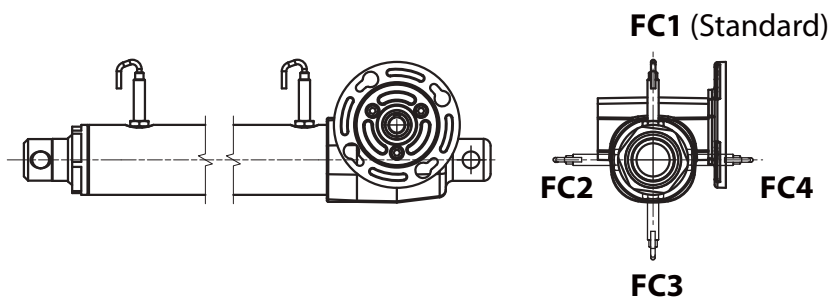

ACCESSORIES AND OPTIONS

Magnetic limit switches FCM

Magnetic sensors are activated by a magnetic field generated by a magnetic ring fixed to the nut. These reads are mounted on outer tube with brackets; outer tube shall therefore be built with non-magnetic materials.

The magnetic switches are fixed as shown in the figure, the customer can rotate at will by adjusting the bracket.

 Due to the size of the magnetic switches and to the so called switching band generated by the internal magnet the maximum working stroke is reduced by a few millimetres. This switching band width differs according to actuators size.

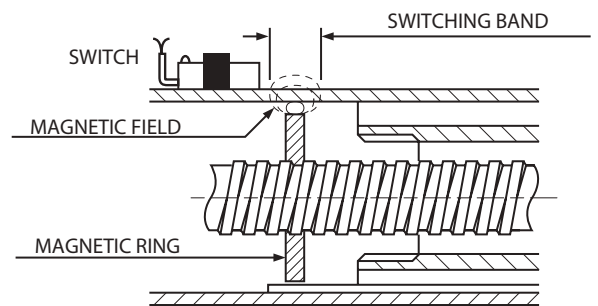
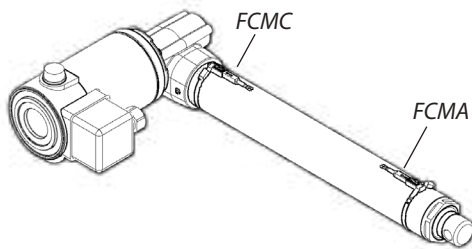

FCMC = All-closed magnetic switch

FCMA = All-opened magnetic switch

Supplied on ALI2 ALI2-P ALI3 ALI3-P ALI4 e ALI5

FCM magnetic Limit switches			
Performance	Type	Type	PNP
	Reed NC	Reed NO	
DC voltage	3 / 110 V	3 / 30 V	6 / 30 V
AC voltage	3 / 110 V	3 / 30 V	/
25°C Current	0,5 A	0,1 A	0,20 A
Power	20 VA	6 VA	4 W
Supply cable	PVC 2 x 0,14 mm	PVC 2 x 0,14 mm	PVC 3 x 0,14 mm
Cablelength		2500 mm	
Protection		IP67	

Circuit Reed NC

Circuit with normally closed Reed switch protected by a varistor against overvoltages caused when switching off, with LED indicator.

Circuit PNP

Circuit with Hall-effect switch and PNP outlet.

Protected against overvoltage spikes and reverse of polarity.

With LED indicator.

Circuit Reed NO

Circuit with normally open Reed switch protected by a varistor against overvoltages caused when switching off, with LED indicator.

ORDERING KEY REFERENCES

Magnetic limit switches:

2FCM0 = 2 Sensors circuit Reed NC
(standard version without prior information)

2FCM1 = 2 Sensors circuit Reed NO

2FCM2 = 2 Sensors PNP

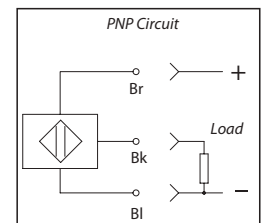
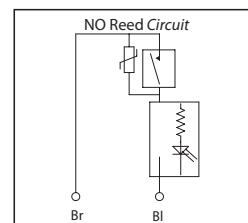
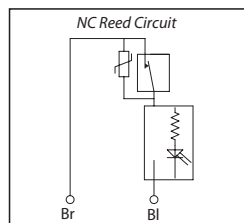

INTEGRATED LIMIT SWITCHES AND POTENTIOMETER

Stroke Control devices Assembly

Potentiometer

Absolute feedback for actuator position monitoring: it can be installed alone or together with limit switches, so to achieve end positions control also. Potentiometer movement comes from the same gearing of the integrated limit switches therefore it has the same limit: long strokes cannot be controlled. Please refer to each actuator performance table to know max achievable length. Furthermore potentiometer electric angle cannot always be achieved.

Version with Limitswitches and Poteniometer

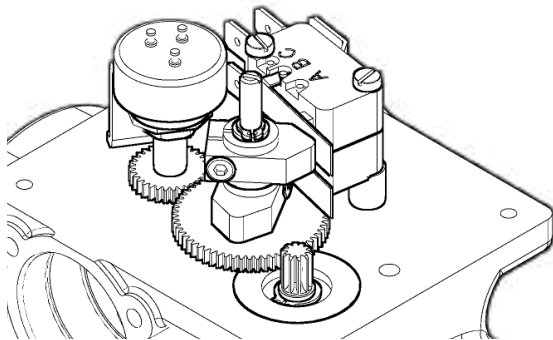

Version with Poteniometer only

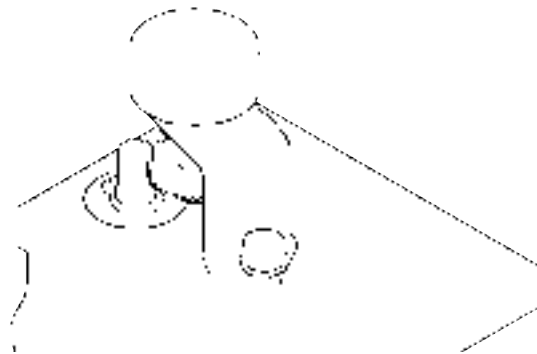

Not Supplied on ALI1 e ALI1-P L02 L03.

Spinning potentiometer

Performances	Type (A)
Max. angle	340° ± 3°
Resistance	1K / 5K / 10K (standard)
Voltage	MAX 10 V
Independent linearity	± 2%
Tolerance	± 20%
Temperature coefficient of resistance	600 ppm / °C

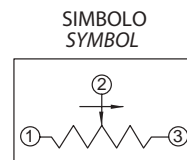
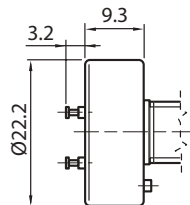
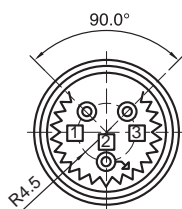

ORDERING KEY REFERENCES

Potentiometers:

POT01A = 1 k Ohm

POT05A = 5 k Ohm

POT10A = 10 k Ohm

(to be adjusted by end-user)

ACCESSORIES AND OPTIONS

ENCODER

Incremental Encoder

An incremental rotative transducer converts spinning movement into digital pulses. It can be installed on actuator, by using a longer worm-screw extension (rotating at the same speed of the motor) and coming out from the gearbox on opposite side of motor, or directly on AC or DC motors.

Its digital output allows for a relative (not absolute) feedback on actuator position, hence, every time machinery is resetted, encoder shall be given the zero position.

Encoder mounted on DC motors(see table below)

Model	Encoder features	Wiring Diagram	Type Encoder
ALI1 ALI1-P	<ul style="list-style-type: none"> Power supply 5 V...24Vdc PUSH-PULL 2 channel - 4 ppr square wave Max output current: 20 mA 		See Wiring Diagram Ali1
ALI2 ALI2-P ALI3 ALI3-P	<ul style="list-style-type: none"> Power supply 5 V...24Vdc NPN open collector 2 channel - 1 ppr square wave Max output current: 100 mA 		E01
L02	<ul style="list-style-type: none"> Power supply 3,8 V...24Vdc NPN + pull-up resistor 3,9 KΩ 1 channel 4 ppr square wave Max output current: 100 mA 		E10
L03	<ul style="list-style-type: none"> Power supply 3,8 V...24Vdc NPN + pull-up resistor 1,9 KΩ 2 channel 4 ppr square wave Max output current: 100 mA 		E50

Encoder mounted on AC motors

Bidirectional incremental encoder, with (standard) or without zero-pulse, protection IP54.

Available ppr: 50 / 100 / 200 / 400 / 500 / 512 / 1000 / **1024 (standard)**

Available output circuits: **Line Drive 5 Vdc (standard)** Push Pull 24 Vdc / Open Collector NPN 10 -30 Vdc / OpenCollector PNP 10 -30 Vdc.

Rosso / Red	÷Vdc
Nero / Black	0 Vdc
Ver de / Green	A
Giallo / Yellow	B
Blu / Blue	Z
Marrone / Brown	-A
Arancione / Orange	-B
Bianco / White	-Z

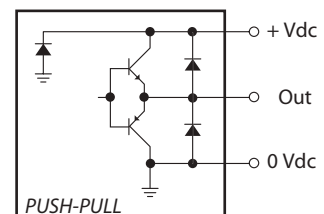
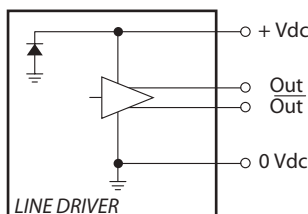

ORDERING KEY REFERENCES

Encoder:

only on DC motor)

E01 = NPN 2 channel 1 ppr

(only on AC motor)

E05 = Push Pull 1024 ppr

E06 = Line Drive 1024 ppr (standard)

E07 = Open Collector NPN

E08 = Open Collector PNP

(only on actuator housing)

E00 = Push Pull 2 channels 4 ppr

E09 = Push Pull 1024 ppr

E10 = Line Drive 1024 ppr

E11 = Open Collector NPN

E12 = Open Collector PNP

E13 = Encoder not considered above
(according to customer request)

Only for L02:

E10= NPN 1 channel 4 ppr

Only for L03:

E50= NPN 2 channels 4 ppr

	E00	E01	E05	E06	E07	E08	E09	E10	E11	E12	E50
AL12-DC		○									
AL12-AC			○	○	○	○					
AL12-P		○									
AL13-DC		○									
AL13-AC			○	○	○	○					
AL13-P		○									
AL14	○		○	○	○	○	○	○	○	○	
AL15	○		○	○	○	○	○	○	○	○	
AL15-P			○	○	○	○					
AV3			○	○	○	○					
ECV9092			○	○	○	○					
L02								○			
L03											○
EC			○	○	○	○					

○ ON REQUEST

ACCESSORIES AND OPTIONS

Antirotation device

Option "L"

The Anti-rotation device avoids push rod spinning around its own axis when travelling: it is essential in case of not guided load. When the anti-rotation device is selected, the front-end is oriented to the rear-end in the assembly phase. The anti-rotation device is made in different ways depending on actuators model.

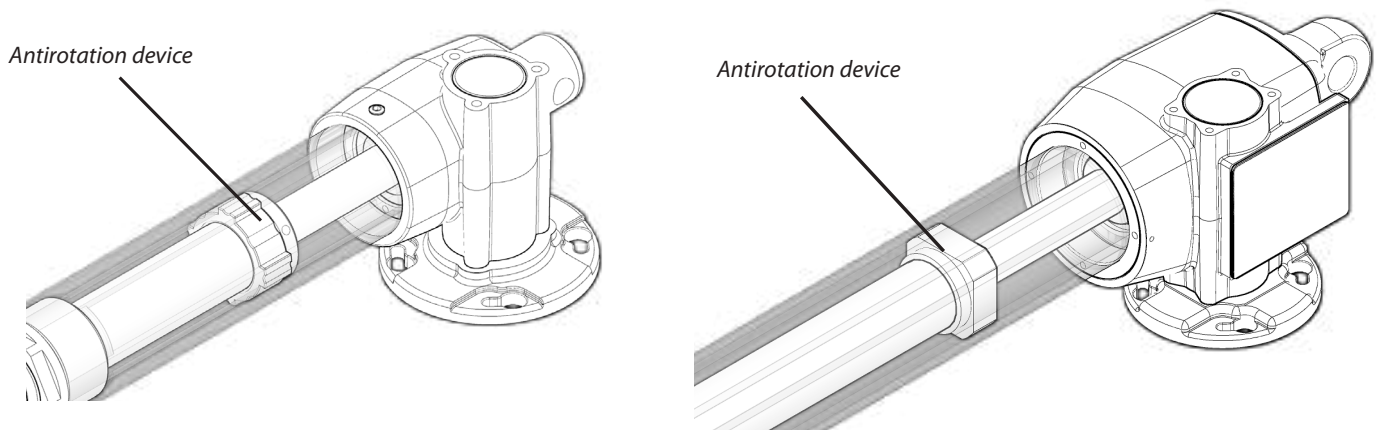

Torque limiter

Option "S"

It is assembled between motor and gearbox to prevent occasional overload. Available for DC and AC motors with IEC flange. As to dimensions contact Technical Department.

Note: Torque limiter reacts at 150-160% of nominal load.

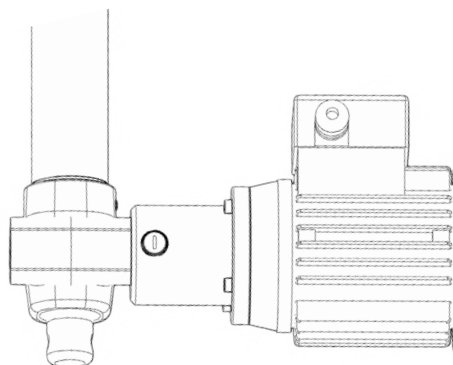

Torque limiter cannot be used as stroke control device with actuator getting to mechanical end-stops. In this way you will lose the torque limiter setting and get it useless

Shaft on motor opposite side Option "T"

Available for models ALI4 and ALI5
As to dimensions contact Technical Department.



Shaft on motor opposite side available only on ALI4 and ALI4-F

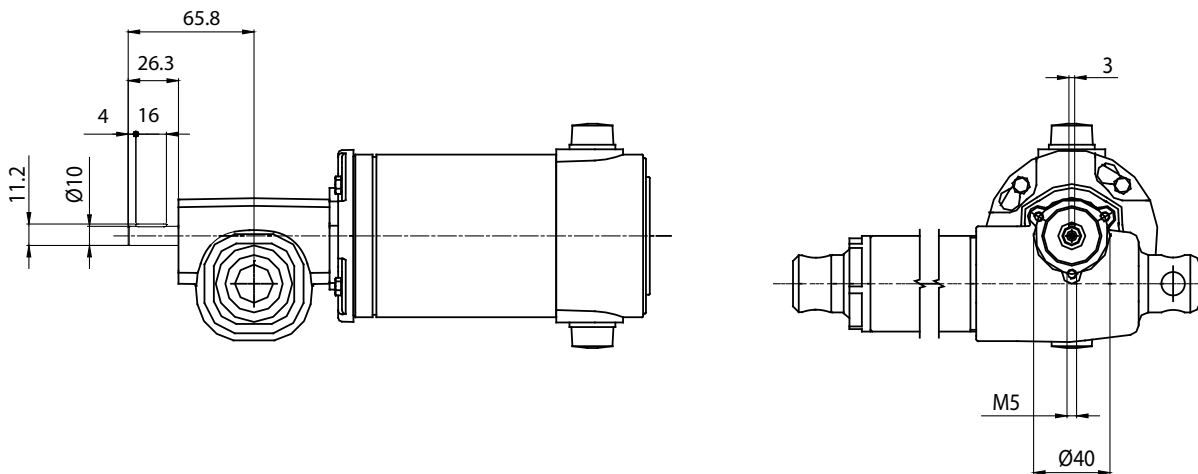

Shaft on motor opposite side available for ALI5

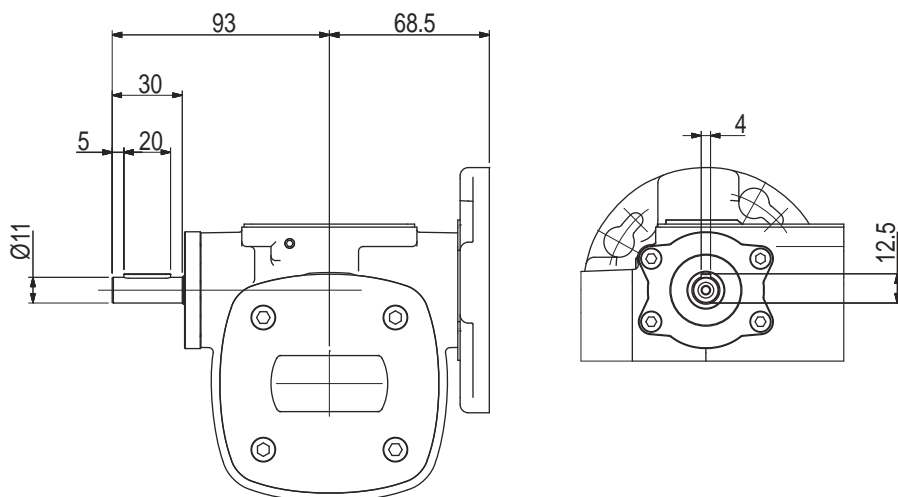

ACCESSORIES AND OPTIONS

Safety nut

Option "G"

The safety nut has been designed to start working only in case of main nut maximum wear. This safety nut is connected to the main bronze nut and travels with it along the stroke.

When the bronze nut is completely worn out, the steel nut starts working on acme screw until it comes to a complete grip to acme screw.

This kind of nut can work in both directions and that is integral with the load in both compression or traction (pushing / pulling)

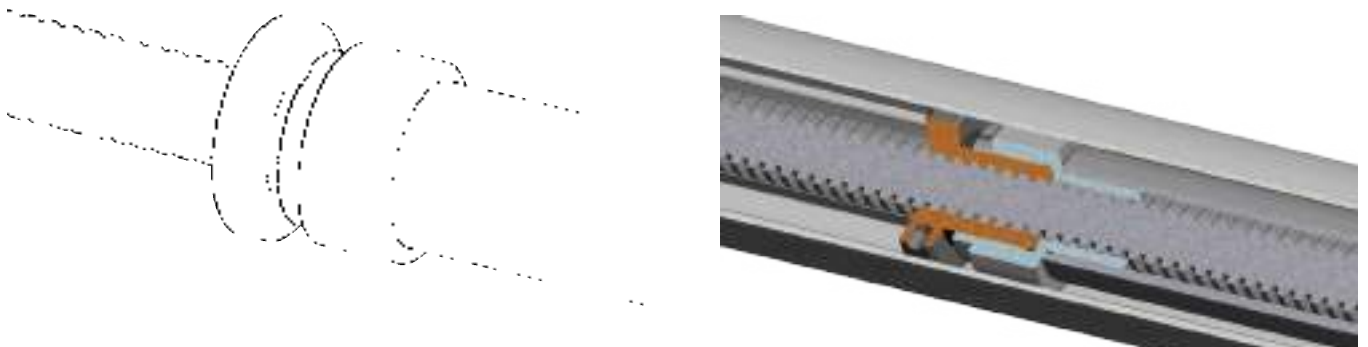

Bellows boot

Option "B"

Bellows boot protects push rods: pharmaceutical and food industries or aggressive environments are typical examples of applications where this option can be required.

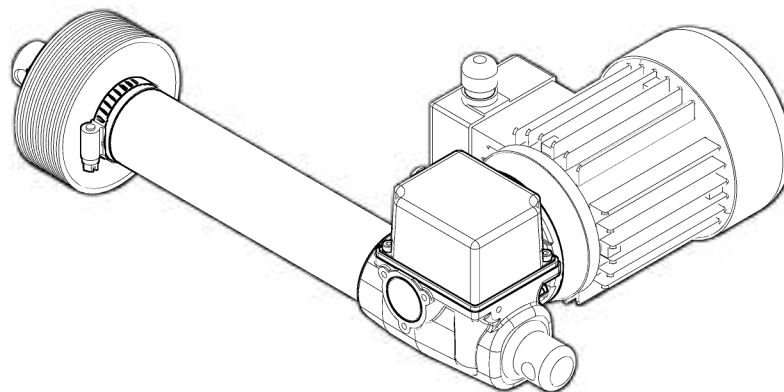

Handwheel and safety-switch unit

Manual driving

Option allowing actuator driving back in case power supply fails or some other inconvenience occurs. Second shafts on the back of the motors or extended worm-screws coming out from gearbox (see Encoder paragraph) can be manually turned with hand wheels, so to let actuator move without power supply for load disengagement. Gearing ratio and screw pitch determine number of revolutions to be done to run whole actuator's stroke: be aware that this number can be quite high.

Option "P" e "N"

Only for model EC

With safety limit switch MS

Option "H"

For all model in A.C.

Only for EC model with safety limit switch MS

OPTION P

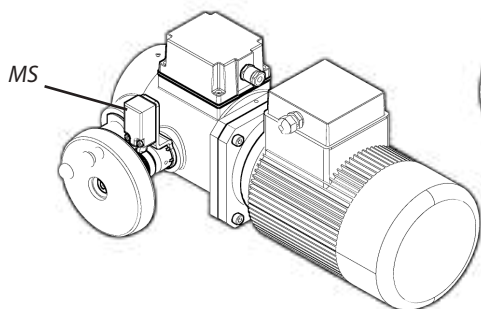

OPTION H

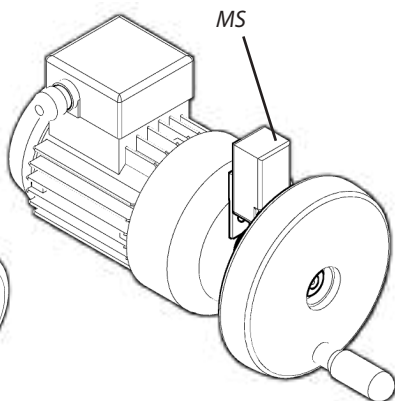

OPTION N

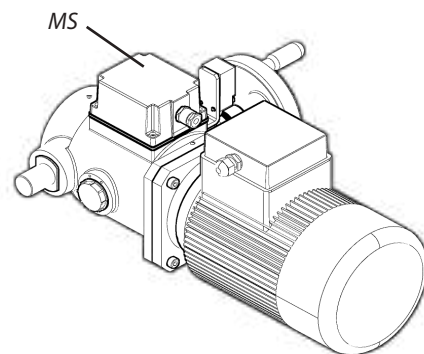

Warning!

"Before connecting motor to power supply, you must connect power to safety microswitch positioned on hand wheel : so you can disconnect motor from power supply pressing safety switch and be able to work in safe conditions"

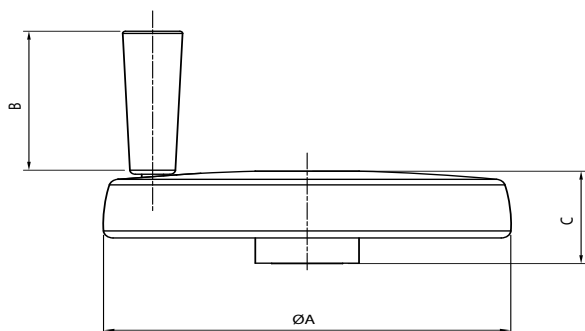

Dimensions			
Model	A	B	C
AL12 AL13 AL14 AL15 EC1 EC2 EC3 EC4	φ150	65	44
AV3 ECV9092 EC5	φ250	90	66

ACCESSORIES AND OPTIONS

A manual driving system is available, for emergency situations.
By removing the cap support, movement can be controlled using a screwdriver.

Option "MM" Mod. ALI1

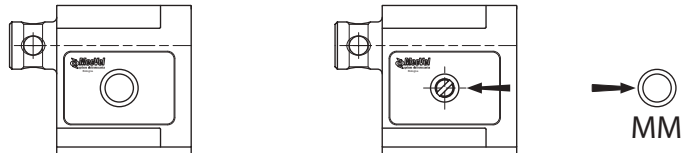

Option "MM" Mod. ALI1-P

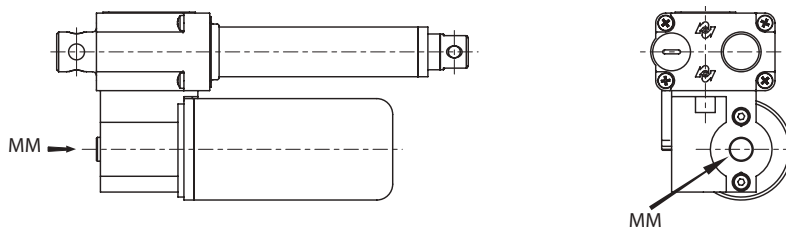

Viton seals

Option "E"

Viton seals are available as a replacement to those of NBR, except models ALI1 and ALI1-P.
For actuators with Option AA (Steel industry version) Viton seals are included.

Inox version

Option "A"

The stainless steel version includes front rear and push rod in stainless steel (X5CrNi18-10)
For AV3, ECV9092 and EC models the push rod is in double chromed .steel.

Tmax NBR = 110°C

Tmax Viton = 200°C

Low noise Version

Option "Z"

It's a version with special solutions for noise reduction.

Protective Painting

Option "FX"

ANTI-CORROSION coating used on all metals and many other materials also against aggressive agents such extreme sea water, industrial fumes, acid rain, etc. .. It also has excellent resistance to impact and abrasion.

Option "FXC"

CATAPHORESIS is a electro deposition of paint in immersion with current continuous electricalworker. The deposited film confers to the pieces ones elevated characteristic anticorrosive, extending in the time the conservation also of all the parts that are not available with a traditional system to spray.

Steel industry version

Option "AA"

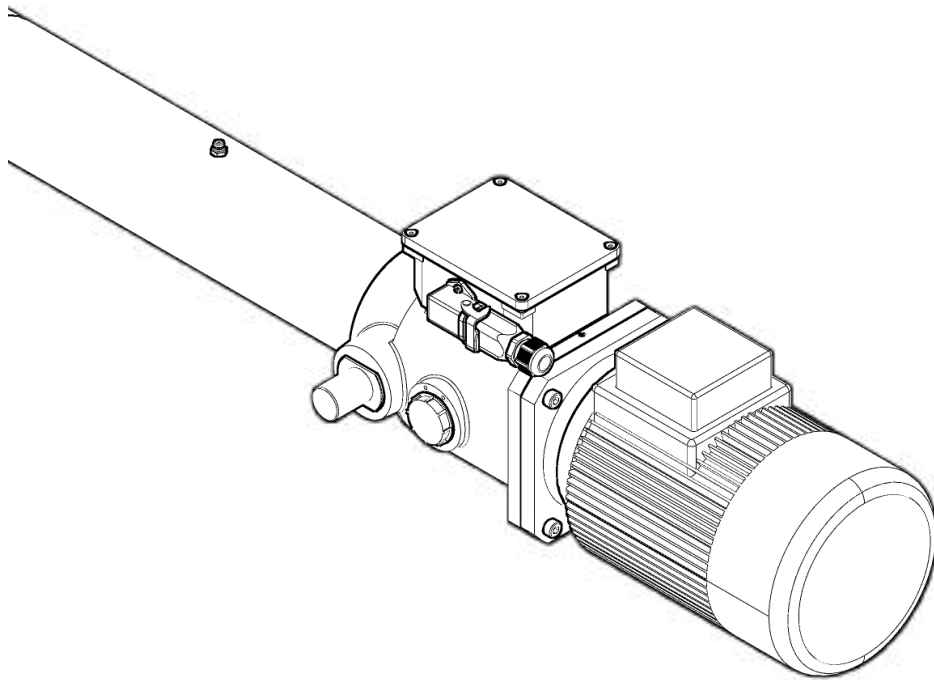





Steel works includes:
Larger limit switches box.
Brass gears and cams.
Metal connectors.
Viton seals.
Mechanical limiter with warning sensor.
Handwheel for manual driving (standard pos.N; optional P and H).
Front end with shock absorber.



For further information contact our technical dept.

ACCESSORIES AND OPTIONS

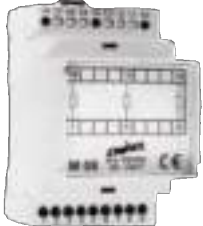

Electronic Devices

Electronic control cards







Code	Data	Application	Picture
PF.0014	<p>Driver for 1 actuator with 24 Vdc motor Power supply: 230 V - max 4A (for 24 Vdc motors) Amperage limitation Sound or light signal of movement</p>	All Ø61,5 and Ø40 motors may work with amperage limitation	
PF.0015	Infrared remote control - 2 buttons for PF0014	Accessory for PF0014	
PF.0050	<p>Driver for 2 actuators with 12 Vdc motor Power supply: 12 Vdc +/- 10% 4-28A (for 12 Vdc motors) Stroke limits control normally closed Amperage limitation Radio remote control - 4 buttons</p>	<p>I MAX = 28A Tutti i motori in All 12V motors Ø61,5 and Ø40 motors</p>	
PF.0100	<p>Driver for 1-2 actuators with 12-24 Vdc motor 15A Power supply 10..48 Vdc Stop by limit switches or programmable current threshold Acceleration and deceleration ramp (PWM) Parameters can be set by external interface, the interface is provided only in the first delivery</p> <p>Optional: CAN BUS Synchronization 2 actuators Radio Control</p>	<p>Dim. 86X72X50 I MAX = 15A All 24V Ø61,5 and Ø40 motors 12-24V</p>	

Code	Data	Use	Picture
<p>CC021.0104 Wattmetric relay</p>	<p>Connection = Motor Full scale = 2,5 / 5,0 / 10,0 A Power supply = 230 Vac Motor power supply = 230 / 400VAC</p>	<p>The electric motor is the most common load to be controlled by an active power relay. The active power supplied to the motor gives the direct information of the instant load of the motor itself. Such information is more accurate than the one given by the current value. As a matter of fact the $\cos\varphi$ variations may change the power value without affecting the current value.</p>	
<p>CC021.0105 3 phase drop resistance M08-8</p>	<p>Option for wattmetric relay Motor power = 440 Vac</p>	<p>The device has 3 resistances built-in when they are connected in series to 3 voltage pins they make a voltage drop. In this way it is possible to apply a voltage higher than the voltage accepted by the voltage pins</p>	
<p>CC021.0002 Transducer of position or signal E 261B-A1-CD (0-10V / 4-20 mA 24 Vdc)</p>	<p>Connection = Potentiometer 1-10 KHom Device power supply = 24Vdc</p>	<p>The device supplies a potentiometer and measures the voltage on the wiper. The voltage and current outputs are proportional to the position of the wiper of potentiometer</p>	



ACCESSORIES AND OPTIONS

Code	Data	Use	Picture
<p>CC021.0022</p> <p>Transducer of position or signal</p> <p>E 261 B- A1-GMA</p> <p>(0-10 V / 4-20 mA / 115-230Vac)</p>	<p>Connection = Potentiometer 1-10 KΩ</p> <p>Device power supply = 115-230Vac</p>	<p>The device supplies a potentiometer and measures the voltage on the wiper.</p> <p>The voltage and current outputs are proportional to the position of the wiper of potentiometer.</p>	
<p>CC021.0107</p> <p>Low voltage current transformer</p>	<p>Option for wattmetric relay</p> <p>Full scale = 2,5 / 5,0 / 10,0 A</p>	<p>If the motor current (or of the application) is over 10A, it is necessary to use a TA.../5 together with Mod.A or TA...1 together with Mod.B and the range will be set at 5A or 1A.</p>	
<p>CC021.010</p> <p>Current relay</p>	<p>Connection = Motor</p> <p>Full scale = 2,5 / 5,0 / 10,0 A</p> <p>Driver power supply = 230 Vac</p> <p>Motor power supply = single / 3 phase</p>	<p>This unit is designed to monitor the current of a load with a max or min set point (built-in CT).</p> <p>It is used to monitor a single or three-phase load (typically a motor) for performing a protection with one alarm.</p> <p>Max set point (or min) divided in 10 parts to be set by means of a small screwdriver on the front.</p>	





Wiring and connector (on request)

Code	Data	Use	Picture
Male Connector Molex from 2 to 12 pins IP 00 (Es. CC010.0010 12 pins)	max 0.75 mm ² max 6 A on the section 0.75 mm ²	Encoder, microswitch and motor wiring	
Female Connector Molex from 2 to 12 pins IP 00 (Es. CC010.0011 4 pins)	max 0.75 mm ² max 6 A on the section 0.75 mm ²	Encoder, microswitch and motor wiring	
Female Connector Deutsch from 2 to 12 pins IP 65 (Es. CC010.0043 4 pins)	from 0.5 mm ² to 1 mm ² max 7.5 A sulla sezione da 1 mm ²	Encoder, microswitch and motor wiring	
Female Connector Deutsch from 2 to 12 pins IP 65 (Es. CC010.0324 6 pins)	from 0.5 mm ² to 1 mm ² Max 7.5 A sulla sezione da 1 mm ²	Encoder, microswitch and motor wiring	
Connector Amphenol 90° 3 or 6 pins (with cor- rugated sheath) IP 65 (Es. CC010.0022 3 pins)	from 0.5 mm ² to 1 mm ² Max 16 A for 3 pin, Max 13A for 6 pin on the section 1.5 mm ²	Motor wiring	
Male connector Amphenol 3 or 6 pins IP65 (Es. CC010.0298 6 pins)	from 0.14 mm ² to 1.5 mm ² Max 16 A for 3 pin, Max 13A for 6 pin on the section 1.5 mm ²	Motor wiring	

ACCESSORIES AND OPTIONS

Code	Data	Use	Picture
Housings bulkead mounting right angle from 3 pin + ground to 16 pin + ground IP 66 (Es. CC010.0304 4pins)	From 0.5mm ² to 2.5 mm ² Max 10 A on the section 2.5 mm ²	Encoder, microswitch and motor wiring	
CC010.0309 Metal Housing, orizzontal input for 10 pins+ ground IP 66	From 0.5mm ² to 2.5 mm ² Max 10 A on the section 2.5 mm ²	Encoder, microswitch and motor wiring.	
CC010.0316 Female Connector Molex 4 pin round PG9	0,16 mmq Max 4A	Encoder wiring	

Transformers

Code	Data	Dimension	Picture
PF.0033	<i>Transformers ET 80PW (80 VA - 230 / 12V Vac)</i>	136 x 60	
PF.0034	<i>Transformers ET 150PW (150 VA - 230 / 12 Vac)</i>	136 x 60	
PF.0036	<i>Transformers ET 80PW (80 VA - 230 / 24Vac)</i>	136 x 60	
PF.0037	<i>Transformers ET 150PW (150 VA - 230 / 24 Vac)</i>	136 x 60	

Swivelling shafts holder.

SP---

To mount actuators series EC, four sizes of shaft holders

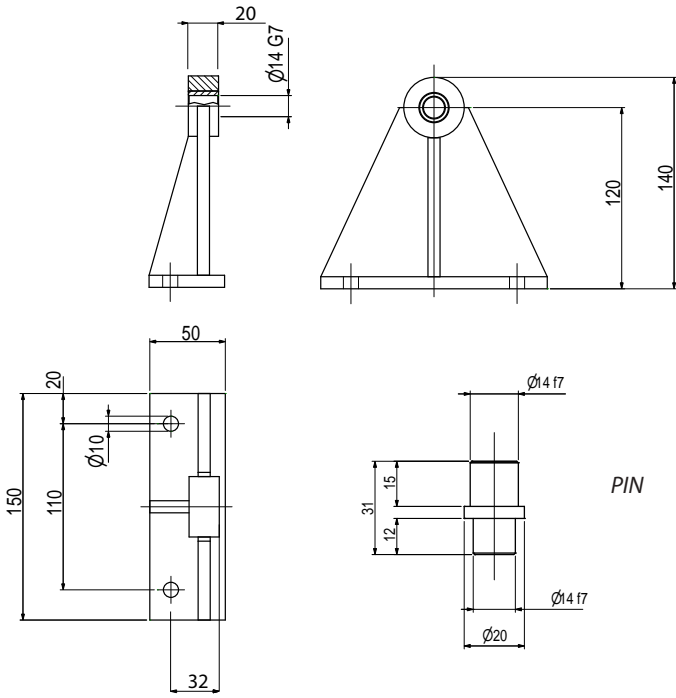
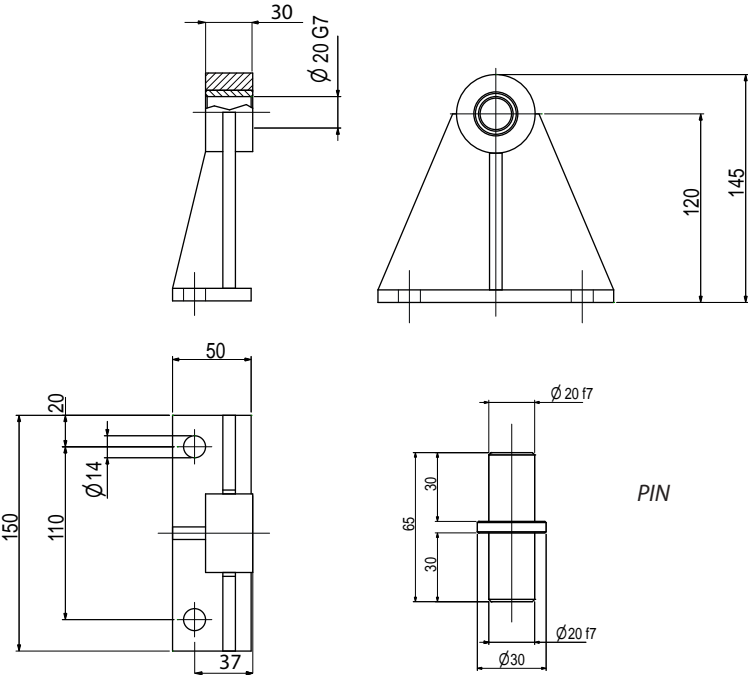
Code	Description	Dimensions
SP0014	Kit of 2 shaft holders for EC1	
SP0020	Kit of 2 shaft holders for EC2	

ACCESSORIES AND OPTIONS

Code	Description	Dimensions
<p>SP0030</p>	<p>Kit of 2 shaft holders for EC3</p>	
<p>SP0040</p>	<p>Kit of 2 shaft holders for EC4 / EC5</p>	

Bracket for front and rear ends

SAA---

To mount actuators having rear connection P1 / P2 and front head A1 and A4 the brackets are available for 3 series (ALI2 / ALI3 / ALI4 / ALI5)

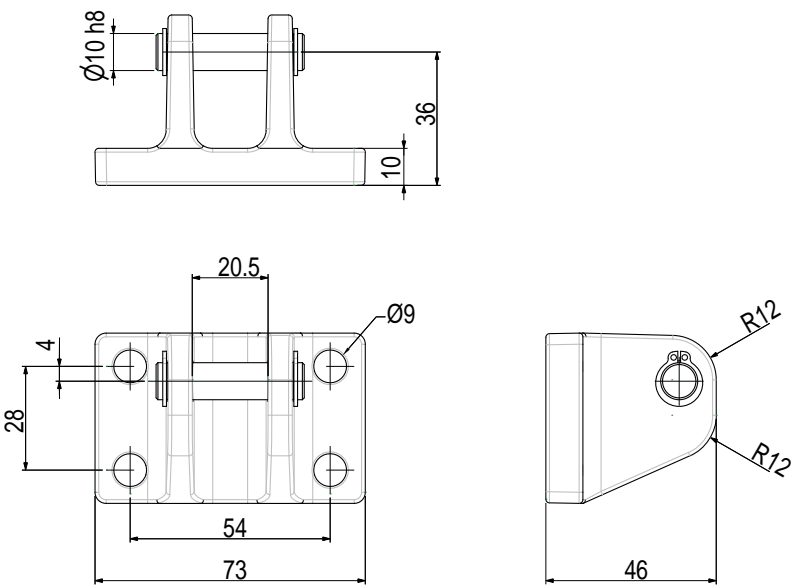
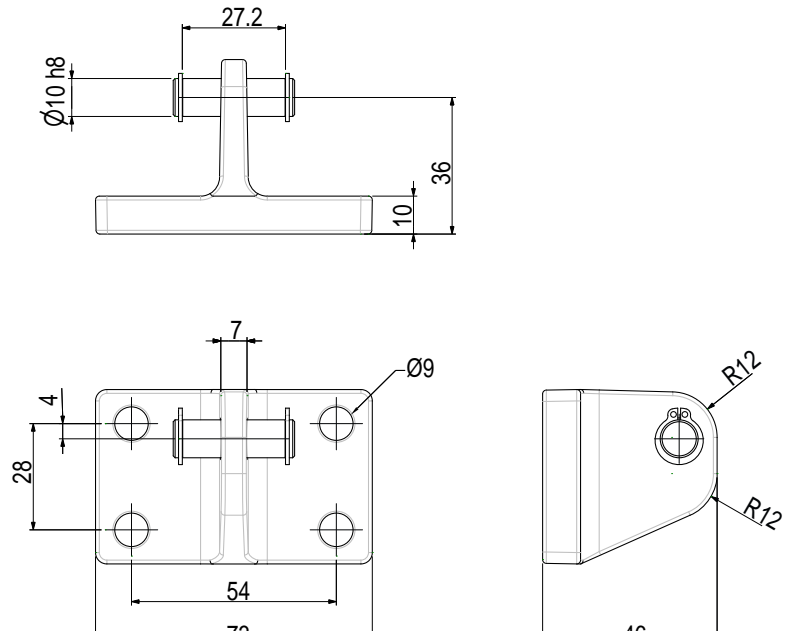
Code	Description	Dimensions
SAA0002	Asymmetric bracket for front and rear ends ALI2	 <p>Technical drawing of the SAA0002 asymmetric bracket. It includes three views: a side view, a front view, and a side view from the opposite side. The side view shows a mounting arm with a diameter of $\text{Ø}10 \text{ h}8$ and a height of 36. The front view shows a rectangular base with a width of 73 and a height of 28. The mounting arm is centered, with a distance of 20.5 from the center to the edge. The base has four mounting holes, with a distance of 4 from the center to the first hole. The side view shows a height of 46 and a radius of R12 at the top corner.</p>
SAA0003	Asymmetric bracket for front and rear ends ALI3	 <p>Technical drawing of the SAA0003 asymmetric bracket. It includes three views: a side view, a front view, and a side view from the opposite side. The side view shows a mounting arm with a diameter of $\text{Ø}10 \text{ h}8$ and a height of 36. The front view shows a rectangular base with a width of 73 and a height of 28. The mounting arm is centered, with a distance of 27.2 from the center to the edge. The base has four mounting holes, with a distance of 4 from the center to the first hole. The side view shows a height of 46 and a radius of R12 at the top corner.</p>

ACCESSORIES AND OPTIONS

Code	Description	Dimensions
SAA0004	Asymmetric bracket for front and rear ends ALI4	<p>Technical drawing of the SAA0004 asymmetric bracket. It includes three views: a front view showing a height of 66 and a base thickness of 15, with a mounting hole of diameter $\text{Ø}12$ and height $h11$, and a distance of 30 between mounting points; a side view showing a total width of 110, a mounting hole diameter of $\text{Ø}11$, and a distance of 13 from the edge; and a perspective view showing a base width of 80.5 and a height of 99.5.</p>
SAA0005	Asymmetric bracket for front and rear ends ALI5	<p>Technical drawing of the SAA0005 asymmetric bracket. It includes three views: a front view showing a height of 58 and a base thickness of 15, with a mounting hole of diameter $\text{Ø}20$ and height $h11$, and a distance of 26.1 between mounting points; a side view showing a total width of 110, a mounting hole diameter of $\text{Ø}11$, and a distance of 13 from the edge; and a perspective view showing a base width of 80.5 and a height of 95.5.</p>

GENERAL SALES CONDITIONS

Art. 1 Applicable law and conclusion of the contract

1.1 Any matter regarding the relationship between MECVEL and the Buyer that is not explicitly or implicitly resolved by the dispositions of the present General Sales Conditions or by possible special conditions agreed upon by the parties and settled in the sale contract (that in case of contrast will be considered prevailing) will be governed by the Italian law.

1.2 Any modification to the present General Sales Conditions must be made in writing.

1.3 The sale contract (hereinafter called "contract") has to be considered as concluded when, on reception of an order, the Producer has sent an acceptance in writing within the term eventually fixed by the Buyer.

Art. 2 Characteristics of the products and descriptive documents

2.1 Any information relating to working characteristics of the products, weights, dimensions, abilities, prices, outputs, and other data contained in catalogues, prospects, circulars, advertising, illustrations or price-lists of the Producer, have character of approximate indications. These information shall be binding only to the extent they are expressly referred to in the contract.

2.2 Any design or technical document enabling the manufacture of the supplied products or their parts, that the Producer has delivered to the Buyer before or after the stipulation of the contract, remains the Producer's property, and the Buyer cannot use, copy, reproduce, transmit or communicate it to third parties without the consent of the Producer.

2.3 The title of any intellectual or industrial right related to the products is and remains of the Producer.

Art. 3 Price

3.1 Unless otherwise agreed the price does not include value added tax, packing, custom costs, transport and accessory expenses, and it is subject to change according to the Producer.

Art. 4 Testing

4.1 Whether technical specifications for the tests are not specified in the contract, the tests will be carried out according to the procedures generally followed by the Producer.

4.2 If the Buyer claims for it at the moment of the order, the Producer has to communicate to him when the tests will take place, in order to allow his representatives to be present.

4.3 Unless otherwise agreed the Producer will be charged of all the expenses of the tests carried out in his establishments, in exception of those for the personnel of the Buyer.

Art. 5 Payment conditions and retention of title

5.1 Payments must be made with the means and to the expiration or expirations arranged by the parties. The obligation of payment is considered fulfilled when the due amount is received from the bank of the Producer in available funds.

5.2 If the delivery occurs before the complete payment, the Products delivered remain the Producer's property until complete payment is received by the Producer.

Art. 6 Interests on delayed payment

6.1 In case of delay in any payment by the Buyer, the Producer can actually suspend the fulfilment of his own obligations until complete payment is effected.

6.2 In addition to what is expressed in the preceding point, the Producer will have the right to interests on delayed payment on the amount that is not paid to the agreed date, beginning from the moment in which the payment is due up to the moment in which the payment is made, previous written notice to the Buyer. The parties arrange to fix the rate of the interests on delayed payment to the.....%.

6.3 Whether the delay of the Buyer in making any payment depends on a circumstance listed under article 10, the Producer is not entitled to any interest on delayed payment.

6.4 Whether the delay of the Buyer exceeds 60 days from the agreed date, the Producer has the right to withdraw from the contract, and consequently to get from the Buyer the restitution of the products and the compensation for damages, previous written notice to the Buyer and without having to require a favourable sentence of any Court.

Art. 7 Time of delivery

7.1 Except as otherwise agreed, the supply of goods will be Ex Works the Producer's establishment. The transfer of risks is determined in conformity to the Incoterms of the International Chamber of Commerce, in force at the moment of the contract conclusion.

7.2 Shall the delivery be delayed for any of the circumstances listed under article 10, or for any action or omission of the Buyer, a reasonable extension of the term of such delivery will be granted, considering all the circumstances of the delay.

7.3 Whether the Buyer does not withdraw the products to the agreed time, however he shall be engaged to make all the payments relating to the delivery as if the material had been delivered. The Producer shall care for the storage of the material at the Buyer's expenses and risks. On application of the Buyer the Producer has to assure the material at expenses of the Buyer.

7.4 Except if the Buyer does not withdraw the material because of one of the circumstances specified under article 10, the Producer can require the Buyer to withdraw the material within a reasonable term. Shall the Buyer, for any reason, not comply in the aforesaid term, the Producer shall have the right to withdraw from the contract, in regard to the part of the supply undelivered because of the above-mentioned breach of the Buyer, and consequently to get from the Buyer the compensation for those damages suffered because of his breach, previous written notice to the Buyer and without having to require the favourable sentence of any Court.

7.5 Possible penalties for delivery delays due to the Producer must be specified in writing at the conclusion of the sale contract, and they shall exclude any other remedy for his delayed delivery or non-delivery.

Art. 8 Warranty

8.1 Within the limits of the following dispositions, the Producer undertakes to remedy any imperfection that is consequence of any project, materials, or processing defect. Such obligation is limited to defects occurring during the period (hereinafter called "warranty period") of 12 months from the date of delivery to the buyer.

8.2 In order to claim the rights settled in the present article, the Buyer has to notify the Producer of all the manifested defects in writing, and he has to give him any possibility to ascertain and remedy them.

8.3 Upon reception of such notification during the warranty period, the Producer has to remedy the above mentioned defects at his own expenses. Except when the nature of the defects makes it convenient to carry out the reparation on the place, the Buyer shall forward the defective parts to the Producer, so that the latter can repair or replace them. The obligations of the Producer are considered duly carried out with the delivery to the Buyer of the repaired or replaced parts.

8.4 Except as otherwise agreed, the Buyer undertakes to bear all the costs and risks of transport of the defective parts, and the Producer those of the repaired or replaced ones, between the place where the material is located and the seat of the Producer and vice versa.

8.5 The defective products which the Producer has replaced according to the present article will be returned to the Producer within and not later than 15 days, from the date of reception of the goods sent for replacement, by the Buyer or by one of his customers on his behalf.

8.6 The liability of the Producer is limited to those defects manifesting under conditions of employment as provided in the contract and during a correct use. The guarantee does not cover defects due to causes arising after the transfer of the risks as described under clause 7.1, neither it concerns the normal deterioration.

8.7 Specially, the Buyer loses the right to the guarantee in the following cases: failure to comply with the instructions of use, installation and maintenance of the contractual products and the original spare parts, any modifications made to the products and their original spare parts without prior written consent of the Producer; any repairs made to the contractual products by persons not belonging to the Producer's network and using non-original spare parts.

Art. 9 Civil liability of the Producer

9.1 Shall the Buyer or his customers modify the products or use them for purposes other than those indicated in the catalogue without having obtained prior written consent to do so from the Producer, the Producer shall not be held liable for any loss or damage caused to people or property.

9.2 Pursuant to and for the purposes of Presidential Decree no. 224/88 the Producer shall be liable for any damages caused to third parties deriving from the use of the contractual products only in the event that the injured party is able to provide unassailable proof of the existence of the damage claimed, and of the causal link between any defects and the damage.

9.3 The Producer shall not be liable in the following cases: if the defect that has caused the damage did not exist at the moment the Producer delivered the contractual products to the Buyer; if the injured party, while aware of the defect and the danger to which it might give rise, deliberately exposed itself to it; if the damage is caused by a failure to comply with the instructions set out in the manual of use and maintenance of the contractual products, or when it is caused by the use of non-original spare parts mounted on the contractual products.

9.4 The Buyer shall promptly notify the Producer of any accident or potential safety issue relating to use of the contractual products.

Art. 10 Force majeure

10.1 Neither party shall be held in any way liable for any non-fulfilment of one of its obligations if, after the conclusion of the contract, there arise unexpectedly causes that prevent the fulfilment (such as strikes, fires, mobilisations, requisitions, embargo, monetary restrictions, riots, deficiency of means of transport, general lacks of raw materials and restrictions to the use of energy), to the extent in which it provides the proof (a) that such non-fulfilment was caused by unforeseeable events beyond its control, and (b) that at the moment of conclusion of the contract it could not reasonably foresee such event and its effects on its attitude to perform its contractual obligations, and (c) that it could not reasonably avoid or overcome such event or overcome its effects.

10.2 The party claiming for liability exemption shall notify the counterpart, as soon as possible and immediately after having discovered the impediment and its effects on its attitude to perform its obligations, of the existence of such impediment, as well as the effects of the same on its attitude to face its own obligations. Similar communication must be given as soon as the cause of liability exemption fails. Failure by the breaching party in giving such communication has the effect to make this party responsible for those damages that otherwise could have been avoided.

10.3 Whether the causes of liability exemption last for more than six months, each party shall have the right to terminate the contract. The parties will arrange the repartition of the expenses born up to that moment for the execution of the contract.

Art. 11 Jurisdiction

11.1 Any matter arising from the present General Sales Conditions and from the single sale contracts governed by them, shall be of exclusive competence of the Court of Bologna. However, as an exception to the above mentioned principle, the Producer is in any case entitled to bring his action before the competent court of the place where the Buyer has his registered seat.



MecVel reserves the right to change products information and/or features without notice; all data contained in this catalogue are purely indicative and not binding for the company.

HT05 HR05

Max force	5 kN
Gear ratios	1:4 1:10 1:16 1:30
Acme screw	18x4
Options: integrated - magnetic - inductive or mechanical limit switches, rotary potentiometer, encode	

HT10 HR10

Max force	10 kN
Gear ratios	1:4 1:10 1:16 1:30
Acme screw	20x4
Options: integrated - magnetic - inductive or mechanical limit switches, rotary potentiometer, encoder	

HT25 HR25

Max force	25 kN
Gear ratios	1:5 1:10 1:30
Acme screw	30x6
Options: integrated - magnetic - inductive or mechanical limit switches, rotary potentiometer, encode	

HT



HT50 HR50

Max force	50 kN
Gear ratios	1:5 1:10 1:30
Acme screw	40x7

Options:
- integrated - magnetic
- inductive or mechanical
limit switches, rotary
potentiometer, encoder

HT100 HR100

Max force	100 kN
Gear ratios	1:5 1:10 1:30
Acme screw	55x9

Options:
- integrated - magnetic
- inductive or mechanical
limit switches, rotary
potentiometer, encoder

HT200 HR200

Max force	
Gear ratios	
Acme screw	200 kN
	1:5 1:10 1:30
Options: - integrated - magnetic - inductive or mechanical limit switches, rotary potentiometer, encoder	70x10

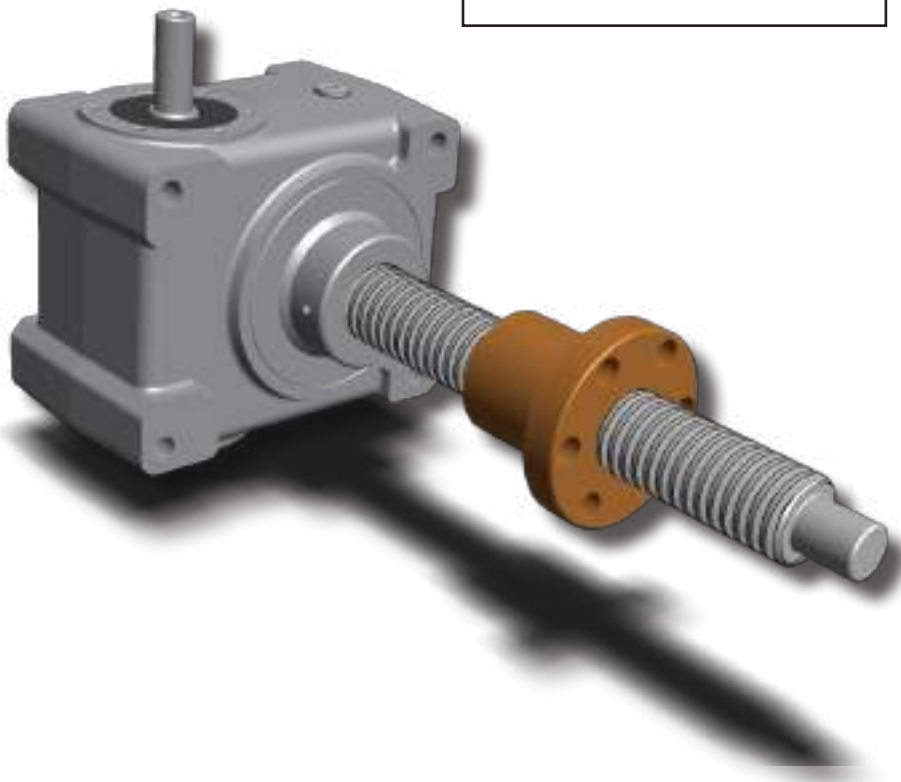

HR

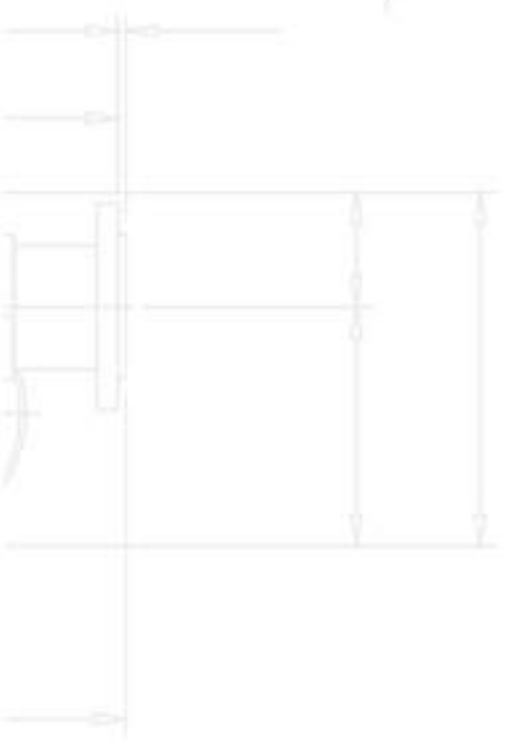
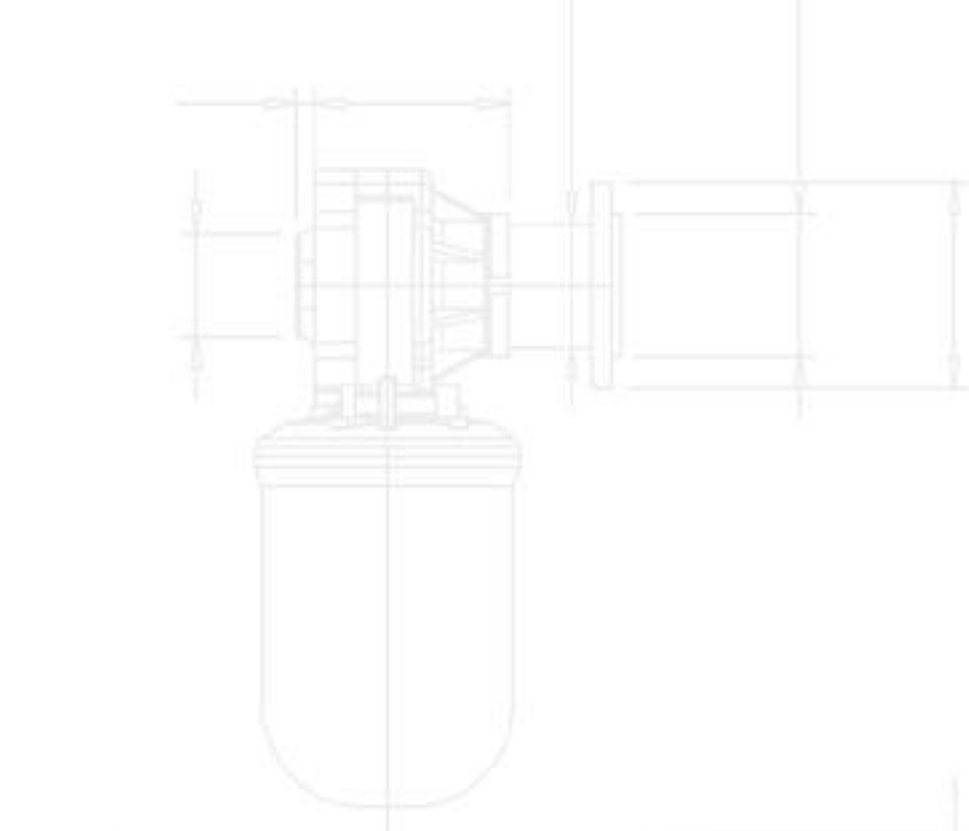

 **MecVel**[®]

MecVel s.r.l.
Via Due Portori, 23 - 40132 Bologna (IT)
Tel: +39.051.4143737 - Fax: +39.051.404567
info@mecvel.com - mecvel.com