

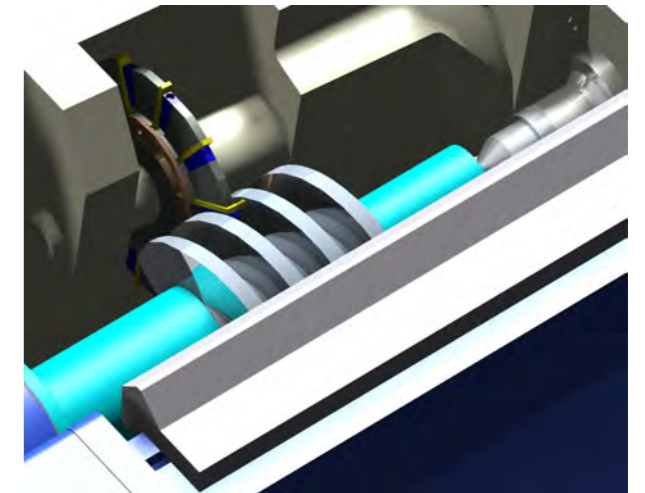

A very important feature and a key point for SAVORITI machines with head for disc cutters as SAR, PLUS CD or DK models is the device patented by SAVORITI for the reduction of the vibration caused by disc cutters.



SAVORITI MACHINES FOR PUMP & COMPRESSOR SCREWS



The Saporiti design and manufacture with knowledge and passion machine tools since 1946. Our first thread milling machine was realised in 1971. Our products are continuously up dated to be keep of a latest technology and to offer always a new generation machine to allow our customers to be really competitive in the market. We have satisfied end user all around the world. Our long experience assure a reliable and accurate production to our Customer.

The pump and compressor screws are with particular and precise shapes and sometimes made by extremely hard materials. For these reasons very often is necessary to use disc cutter with coated tips or in high speed steel with opportune shapes. The **SAVORITI** thread milling machines allow the use of these specials tools. These machines are in different sizes to work screws with diameter from 15 mm up to 500 and length even up to 8000 mm or more.

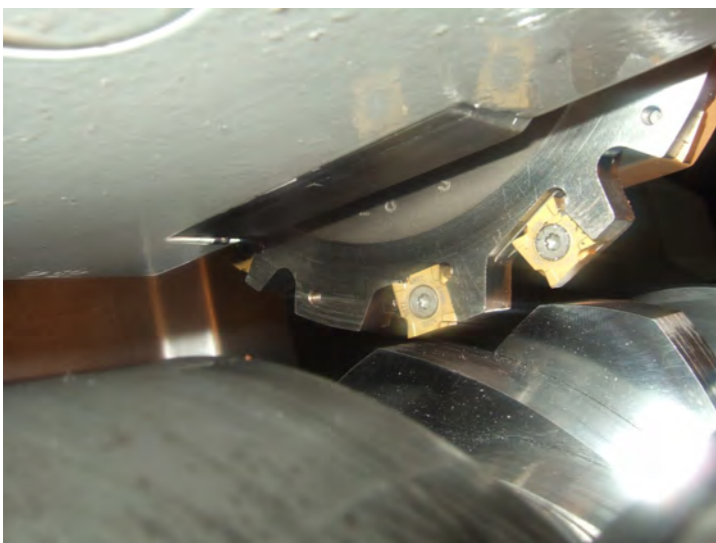

SAVORITI srl

SAVORITI MACHINES



SAVORITI Srl Via dei Patrioti, 58 Solbiate Olona, 21058 (VA) ITALY

Tel -39 0331649196 fax -39 0331643136

www.saporiti.it email: info@saporiti.it

www.saporiti.it



WWW.SAPORITI.IT

All the machines runs on roller sliders to assure the max. possible accuracy and the best surface finishing and use latest technology and first quality components. All the versions are equipped by CNC Siemens. The milling heads use sealed coolant chilled motors. These motors are silent and of latest generation to limit energy loss. In the CNC can be insert customised pages to facilitate the programming and the machine use by the operator.

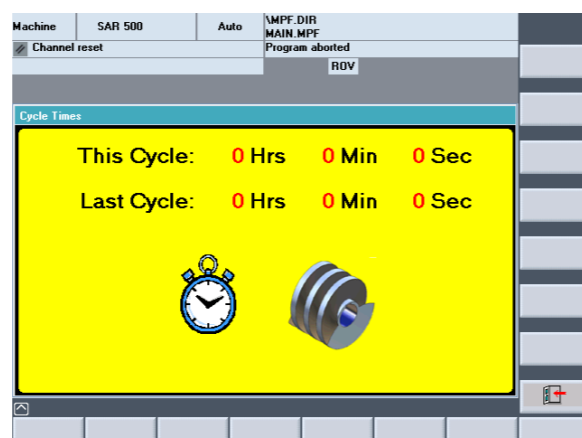
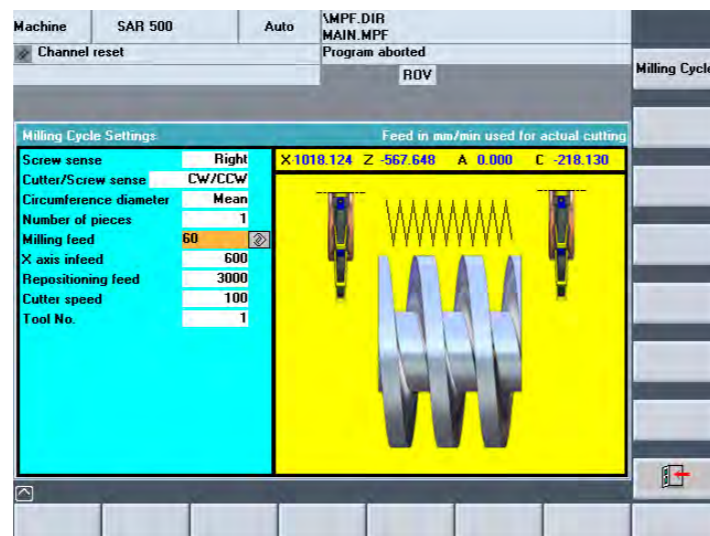
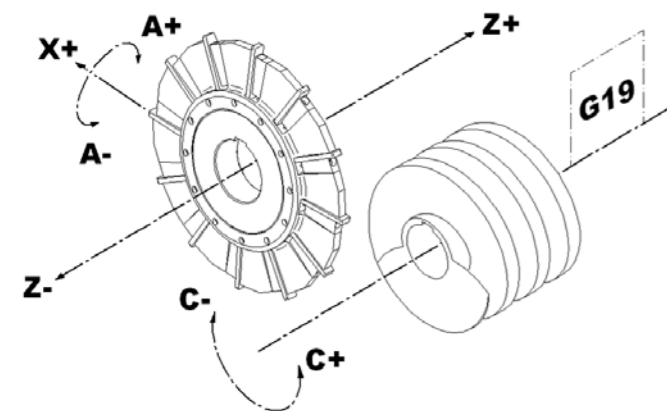

Available models with horizontal or slanted bed also with whirling heads for special screw shape. Our **SAPORITI GRM** models have whirling head. The **SAPORITI SAR** is a machine with Disc cutters head for cutters with max diameter of 440 mm and horizontal bed for screws with diameters from 150 mm up to 500 mm and length up to 1500 mm. The models **SAPORITI DK** and **SAPORITI CD** are suitable for max 250 mm screws diameter and length up to 8000 mm. They are with slanted bed and with max cutter diameters of 250 mm and 220 mm respectively. The machines tailstocks have a special shape to allow the inclination of the disc cutter heads with the less possible distance with the workpiece.



In the **SAPORITI SAR 500** the extreme machine rigidity allow high chips removal and very good surface finishing. It is possible work by inserts cutters up to 80 mm deep by only one passage even material very hard as stainless steel type 17- 4PH (320HB)

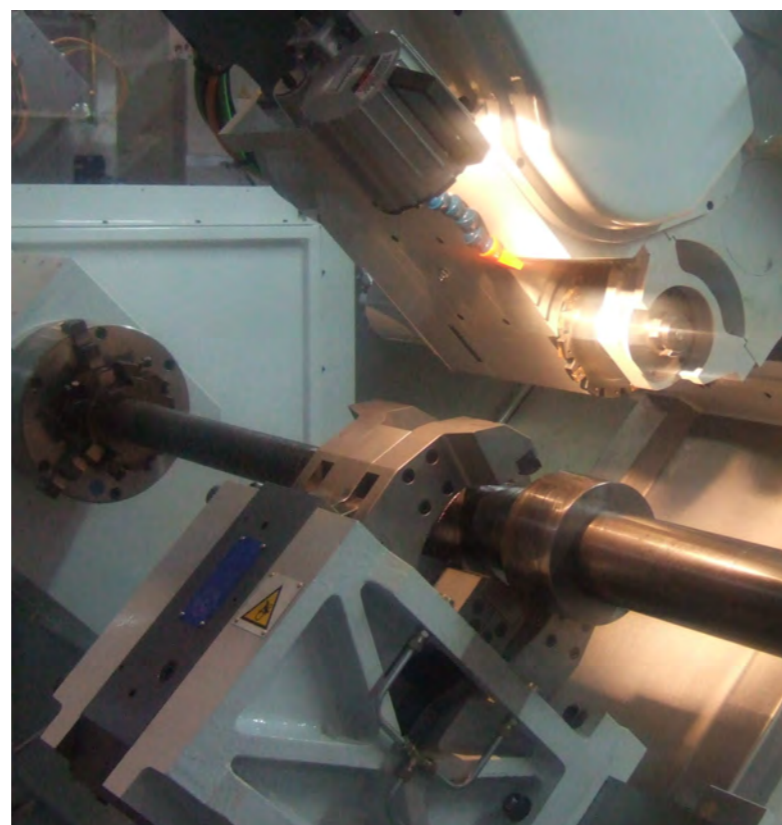
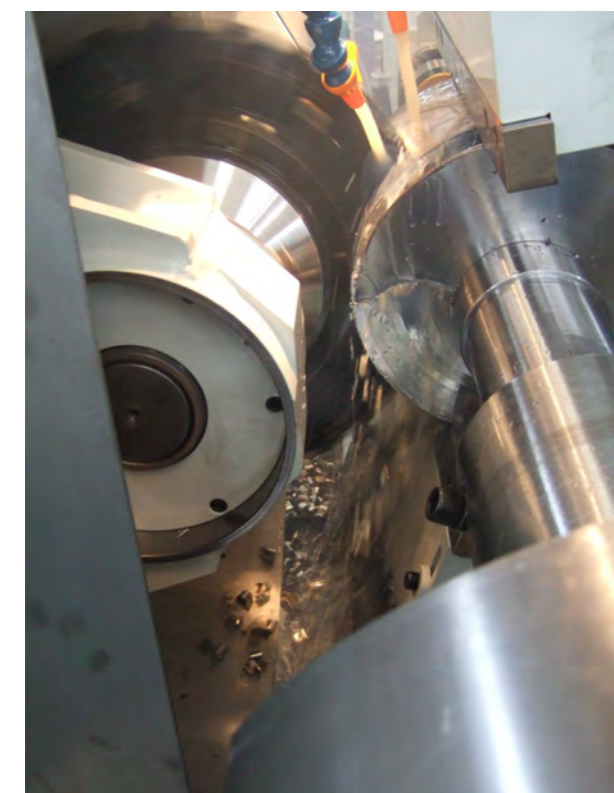

WWW.SAPORITI.IT