

CUF

MILANO

OFFICE LANDSCAPES  SINCE 1986

CUF

MILANO

OFFICE LANDSCAPES  SINCE 1986

CUFMILANO
OFFICE LANDSCAPES  SINCE 1986

Tel. +39 02 253771 - fax +39 02 2542100
20124 Milano - Italy - viale Andrea Doria, 17
www.cufmilano.com - info@cufmilano.com

COMPANY

CufMilano was founded in Milan in 1986. We are specialized in manufacturing and distributing office furniture, chairs and demountable partitions.

We are proud to show our numbers after 30 years of experience in the field:

- 20 showrooms in Italy;
- 5 warehouses with ready in stock items for quick delivery;
- 3 production sites.

OUR MISSION

Client satisfaction.

Our clients are the biggest value in the company, we continuously work for make them happy and comfortable.

High Quality items and customer service.

We combine high quality and made in Italy standards at affordable prices.

Our Team.

Our employees are our wealth, the daily commitment of our people is what makes the success of our company.

OUR REFERENCES



PROFILE

OUR STRENGTHS



Ready in stock products for immediate delivery.

Most of the items (Executive, Operative and demountable partitions) in standard finishes ready in stock.



Custom made

We realize products tailor made based on project.



100% MADE IN ITALY



Design and technical assistance

Our team of architects is supporting with project proposal, 3D and render.



Turnkey

We can supply all the items connected to office renovation: drywalls, lightings, floors, suspended ceilings.



Straight from the factory.



All the items are certified with European stability, safety, chemicals laws, so that their quality is guaranteed.

The company is certified for quality, environmental and workers-safety standards.

Vittoria

Design
D. LO SCALZO MOSCHERI

The elements making up the project are characterized by an only one proportions language, on the linearity and dignity of the materials.

The involvement of steel, glass, laminate and engineered stone define a neutral hue but firm: the laminate tones belongs to the warm grey and natural oak, combined with bronze and metal. Vittoria is a project that reveal multiple configurations, and introduce the concept of

glass showcase: a simple accessory, that became a privacy screen or a storage compartment. Top and sides desk's are in honeycomb core with double laminate panels, with brushed oak texture in the two finishes tobacco and ash grey oak. Desks can be equipped with a 6mm Gres with Sahara Noir and Calacatta Gold finishes. On desks can be added meeting table with metal structure and smoky grey glass.



Executives







“Design is a matter of opinion, not a solution.”



Magenta

Design
D. LO SCALZO MOSCHERI

The structures with varnished frames can be equipped with sides laminate panels in different finishes. The panels for inside structures are in special silky and antiscratch finishes. Tops are in laminate, with important edged



thickness, available in Tobacco and Ash Grey finishes. Modularity of the structural frame and tops, also available in glass, allow to create different matches and innovative configurations. The pedestal drawers are available on castors wheel

or integrated on structural side desk. Cabinets are in laminate with metal glides. Magenta has multiple combinations, either with corner composition or with free standing elements.



















Brera

Design
L. GLORINI

The Executive Office compact and essential, selection of finishes in Oak Walnut and Wengè, 38mm thickness of panels for a great stability. Brera collection desks can be realized as simple desk, or with side returns used as a side leg. These elements are supplied with a white metal

filing pedestal and cabinet. Brera bookcases are produced in two different way: like the classic cabinets, with wooden or glass doors, in three different heights (low, medium and high), or as a bookcase without doors, with back, sides and shelves realized in the same desk colors.

Executives













Seventy Seven

Design
PROGETTO CMR

An office furniture system, characterized by the combination and coexistence of the performance needed in the work environment and an aesthetic language able to reside in both working and domestic settings. An object with very high performance that presents, at the same time, an original, young, fresh and domestic image. The final result is an operative desk series characterized by a slim plane

that leans on top of a fleeing structure adorned by connection elements that, starting from the beams, evolve to embrace the table legs. The table top sizing is pushed to unusual depths (77 and 57 centimeters) in order to take advantage of a perfect modularity in situations in which the workstations are at a 90 degree angle between each other.

The accessories completing the system resume and take to the extremes the light aesthetics theme, working with slim metal plate and framed volumes. The aesthetic choices, as well as the material selection and hidden structural elements, give to the system a versatility of language that makes it adapt to be put in architectonic environments that present very different peculiarities.

Workspaces





























Fusion

Design
J. BENNETT
S. ADACHI

Office work environment is becoming more and more versatile. It is not only a place to work, but also to meet and chat, to eat and drink, to rest and relax and to do many other activities. The office system Fusion is what makes architecture functional as well as what helps people do various activities they have to do in the office. Fusion is constructed based on a kind of three dimensional frameworks.

Every detail is carefully designed around people's behaviors and activities in office space. There are designated storage spaces for personal and workplace belongings, to articulate and get better management of space. A variety of configurations create different atmospheres and landscapes, which are not only for solo and collaborative working, but also for impromptu meetings and short breaks in a

more relaxed and home-like environment and less institutionalised context. Fusion is an office system that responds also to a new scenario like co-sharing and co-working spaces. Workplace should be like a kind of social network, but with real people. They want to enjoy themselves, express their personalities and individual characters even though when they are working as a team.













“All big changes are simple.”















Doria

Design
L. GLORINI



The modular eclectic collection, with slim and linear shapes, with glass for executives or wood for operatives, pleasant and colourful with the multicolour finishes. Worktops made of wooden panels in 18 mm thickness, ready available in white veined, light oak or dove-grey and other 20

finishes on demand. For a unique desk is possible to ask for the POP collection with a custom glass top with a print based on client image. Connecting desks, long shelves and meeting tables complete the series of horizontal supports. Legs are also available in different shapes for

DELTA and RING collections and all metal parts are available in white, bonderized grey or chromed and further 5 different Ral colours on client choice. The collection is completed with meeting tables, cabinets, libraries, coffee table and standing meeting tables with the height of 100cm.



















Pop

Design
L. GLORINI





Delta

Design
L. GLORINI





Ring

Design
L. GLORINI









Isola

Design
L. GLORINI

Isola is the classic and evergreen desk, clean lines and surfaces, solid tops with smart beams and legs concealing cables. Worktops realized with a scratch resistant melamine surface, in 30mm thickness and ready available in solid grey or birch veined, other 20 additional colours can be selected to match the client taste. Metallic frame, made up of a central, cableable beam, connected to side legs, which can also be wired, to keep any cables hidden inside the structure. The entire metal structure is available in grey colours or white. Isola is available also in height-adjustable version, with electric system, called Isola-Up.









Aquarius

Design
P. RIPAMONTI

Aquarius is a single glazed evanescent partition that will seduce you for the cleanliness of the lines: brilliant and clear glass will allow natural light to spread in the ambience; in double glass version, Aquarius Duo will ensure a great acoustic comfort.

Partition walls













Custom made panels and profiles

The wall cladding is a Taurus wall partition, here shown with fabric upholstered panels with aluminium frame and wooden veneer panels with concealed profiles: the panels dimensions is a module of w100cm x h109cm.

Aquarius glass partitions with wood veneer laminate profiles, a solution that combines clean shapes and warm materials.





Aquarius Duo

Design
P. RIPAMONTI









Gemini

Design
P. RIPAMONTI

Spacious cabinet partition, flexible with the combination of doors and easily equipped with different shelves, create insulate rooms with technical walls.













Taurus

Design
P. RIPAMONTI

Modular partition with vertical or horizontal lines, elegant with different frames, prestigious with glass and clean with the wooden module, fire and acoustic certified for the best results in many applications.











MEETING ROOM
1



Aquarius

Glazed partition wall composed of anodized aluminium profiles, stratified glasses 5.5.1, swing glass/wooden doors. Maximum wall height 3100mm.

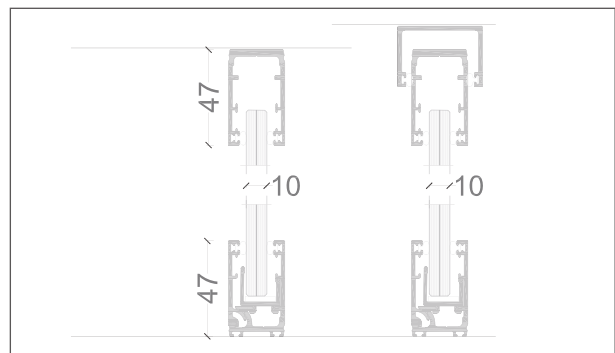

VERTICAL SECTION

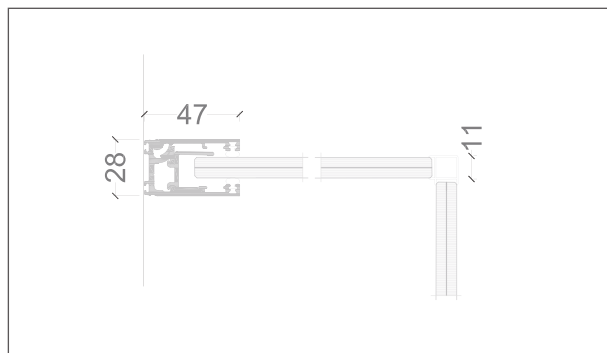

90° ANGLE

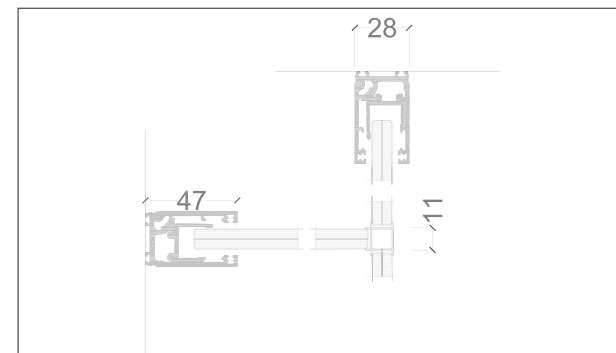

"T" JUNCTION

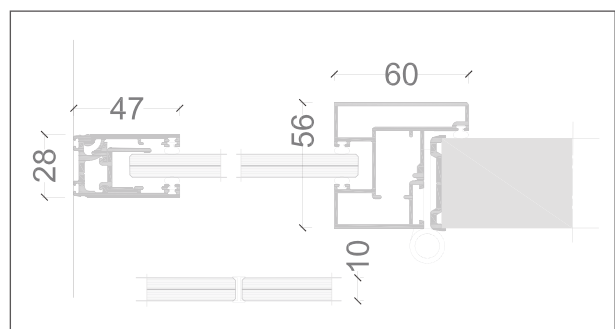

HORIZONTAL SECTION WOOD DOOR

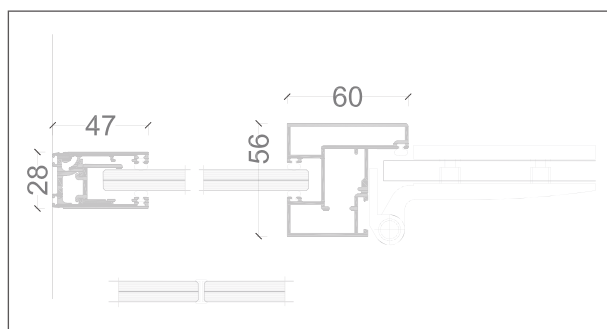

HORIZONTAL SECTION GLASS DOOR

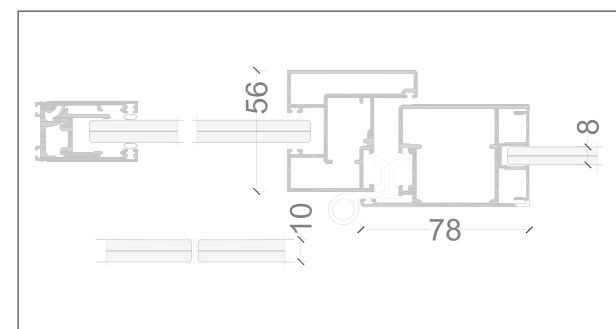

HORIZONTAL SECTION GLASS DOOR WITH FRAME

Aquarius Duo

Double glazed partition wall composed of anodized aluminium profiles, double stratified glasses 5.5.1 for high acoustic performance, swing glass/wooden door. Maximum wall height 3100mm.

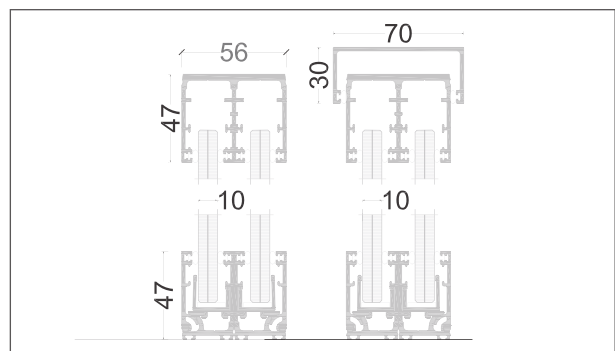

VERTICAL SECTION

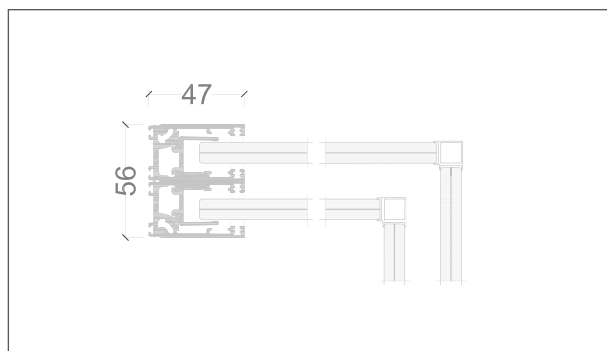

90° ANGLE

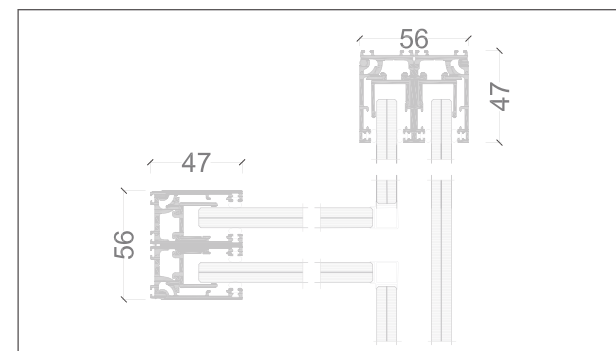

"T" JUNCTION

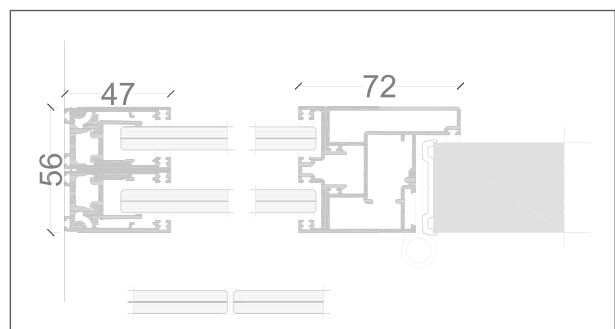

HORIZONTAL SECTION WOOD DOOR

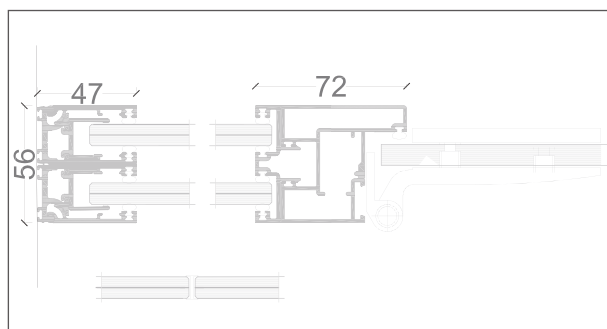

HORIZONTAL SECTION GLASS DOOR

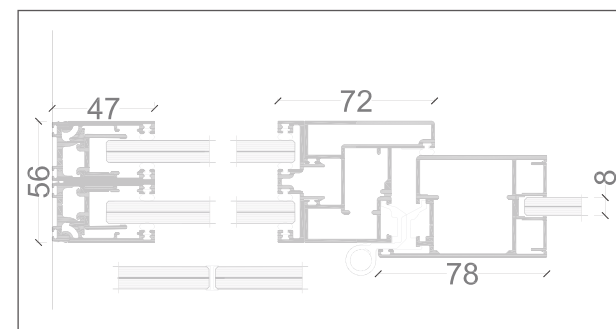

HORIZONTAL SECTION GLASS DOOR WITH FRAME

SECTION LAYOUTS

Taurus

Modular Wall partition, with steel structure, panels are wooden melamine in 18mm thickness, extruded aluminium profiles with stratified glasses of 3.3.1, swing glass/wooden doors. Maximum partition height of 3400mm. Taurus is certified ETA 18-0528.

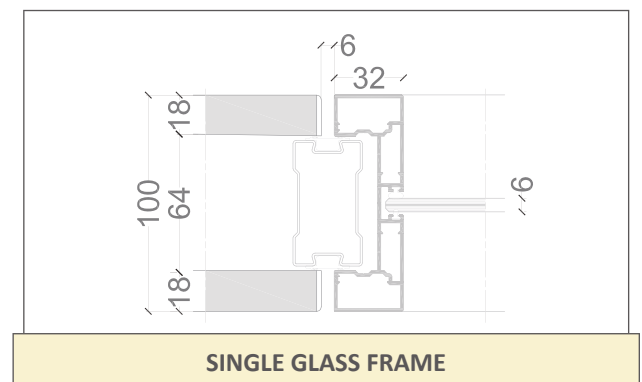
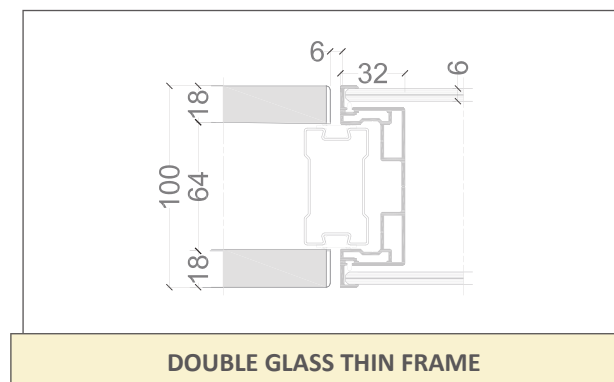
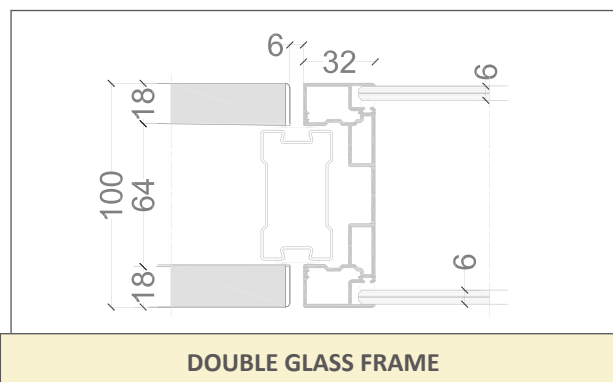
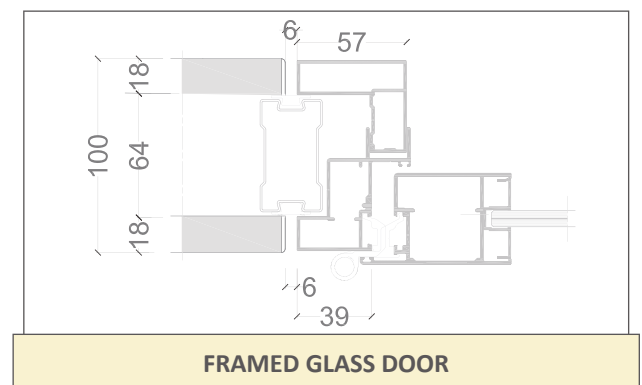
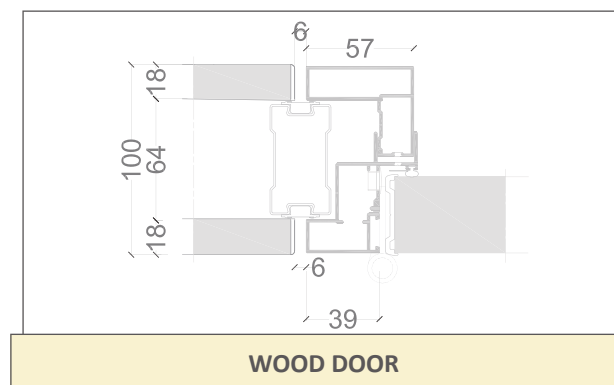
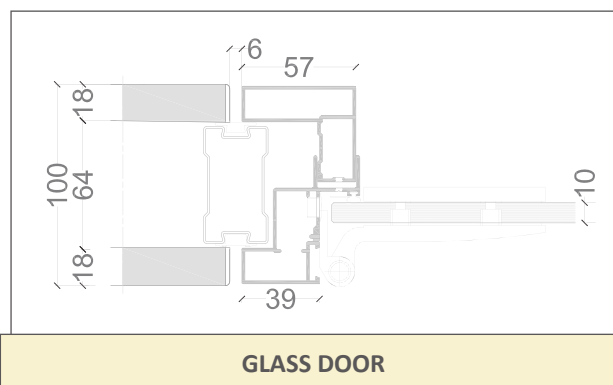
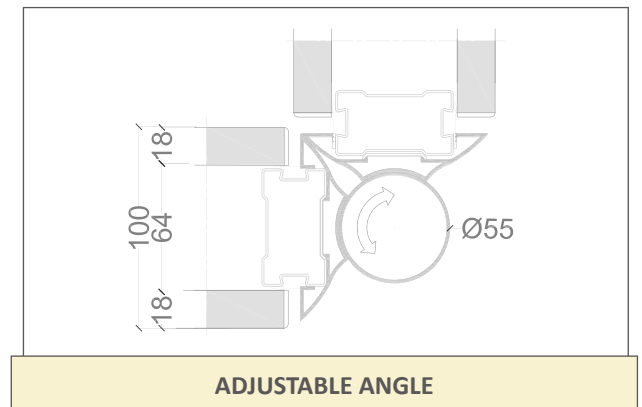
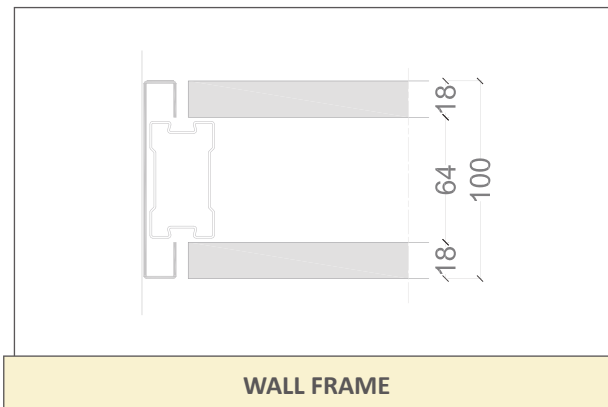

Tetrix & Onda

Tetrix, Onda and Tile Acoustix are colourful fabric panels, available in different dimensions that perfectly combines aesthetic and sound absorption, suitable in any situation where acoustic comfort is desired. The entire elements are Green friendly, made of recycled and recyclable content,

moisture resistant with washable surface. The involvement of Tetrix, Onda and Tile Acoustix contributes to Leed certifications. Acoustic performance of the elements are in the range of $\alpha_w=0,65$ up to $\alpha_w=0,95$ according to the installation method.

Tile Acoustix





Isola Up

Isola Up is the ergonomics sit-stand desk that allows the users to change their working position during the day, simply adjusting height of the desk trough a motorized system.





Wood Acoustix





Wood Acoustix is the elegant acoustic absorption system suitable for walls and ceilings, made of modular MDF boards with a perforated, microperforated or slotted surface. Finishes available in melamine, veneer, varnished, leather and fabric finish.

Designers:

DANIELE LO SCALZO MOSCHERI

PROGETTO CMR

SAKURA ADACHI

JOHN BENNETT

PAOLA RIPAMONTI

LUIGI GLORINI

CUF

MILANO

OFFICE LANDSCAPES  SINCE 1986

Viale Andrea Doria, 17
20124 Milano - Italy
Tel. +39 02 253771
Fax +39 02 2542100
info@cufmilano.com
www.cufmilano.com



