

**AUTOMHA**

SOLUTIONS  
BOOK





**AUTOMHA**

SOLUTIONS  
BOOK

|  |           |
|--|-----------|
| <b>1. Automha Solutions</b>                                      | <b>12</b> |
| • <b>Pallet warehouses</b>                                       | <b>13</b> |
| • Multi-deep pallet storage solutions                            |           |
| - Automated  |           |
| - Semi-automated   |           |
| • Pallet storage solutions in selective mode                     |           |
| - Single-deep  |           |
| - Double-deep  |           |
| - Triple-deep  |           |
| • Solutions for handling with the use of anthropomorphous robots |           |
| - Layer picking  |           |
| - Package handling   |           |
| • <b>Warehouses for boxes, trays</b>                             | <b>24</b> |
| • Order processing, e-commerce                                   |           |
| • Production supply  |           |
| • <b>Vertical warehouses</b>                                     | <b>28</b> |
| • Long items and molds   |           |
| • <b>Warehouses in the textile and synthetic fibre sector</b>    | <b>30</b> |
| • Swatches   |           |
| • Reels  |           |
| • <b>Special warehouses</b>                                      | <b>33</b> |
| • Automotive   |           |
| • Vertical Farming   |           |
| <b>2. Handling Systems</b>                                       | <b>34</b> |
| • <b>Automatic</b>   | <b>35</b> |
| • Pallet conveyors, boxes  |           |
| • Automated guided vehicles                                      |           |
| • <b>Manual</b>  | <b>38</b> |
| • Extendible conveyors   |           |

- 3. Software ..... 40
  - **AWM** ..... 41
    - Warehouse management software
  - **SYM** ..... 44
    - Dynamic simulation and virtual commissioning software
  - **HMI** ..... 45
    - Warehouse-operator interface software
  - **LOG** ..... 46
    - Semi-automated warehouse management software
  
- 4. Customer Services ..... 50
  - **Revamping** ..... 51
    - Warehouse modernization and certification in compliance with the latest safety standards
  - **After-sales assistance** ..... 51
    - 24/7
    - Spare parts
    - Ticketing and defect management service
    - Predictive maintenance
  - **Virtual Commissioning** ..... 51
  
- 5. Automha products ..... 52
  
- 6. Worldwide references ..... 64

## Why automate?

To make it easier to **add automation** to the corporate process, Automha's engineering department carries out thorough feasibility studies, analysing the data and requirements in each specific case in order to create the most suitable solution for each business. Automha accompanies customers through every stage of project implementation, carefully following the planning



**AN AUTOMATIC WAREHOUSE IS A SYSTEM WITH A HIGH LEVEL OF PROCESS AUTOMATION, OBTAINED BY INTEGRATING DIFFERENT SYSTEMS (CONVENTIONAL, AUTOMATIC AND DIGITAL).**

Automatic warehouses are now among the most used systems in the management of material storage and handling operations. The various types of automatic warehouse available on the market bring undeniable business benefits from a number of perspectives:

- **Space optimization:** spaces savings from 50 to 95% when storing the same goods;
- **Operator safety:** in automatic systems, picking is carried out according to a "goods to person" scheme, which ensures greater safety for the operators working in special picking stations;
- **Warehouse stock traceability:** stock management has never been so simple. The system can determine the contents of a specific pallet and indicate the warehouse entry date, shipment date and order under which it was shipped;
- **Improved order fulfilment efficiency:** automation brings immediate optimization in picking times and order lead times, eliminating errors and significantly improving performance;
- **Simple quality control management:** the warehouse is the best ally for quality control management. The system can independently determine how many and which pallets to check, based on rules imposed by the management software;
- **A tailor-made solution:** Automha is well known in the sector as the "tailor" of automation as it creates bespoke solutions for each customer, to meet any storage requirement.

**WHEN DESIGNING AN AUTOMATIC SYSTEM, IT IS ESSENTIAL TO CONSIDER AT LEAST TWO ASPECTS: HOW PICKING AND PLACING WILL BE DONE**



By limiting human intervention, an automatic warehouse can maximize the available space. The systems needed to achieve these two benefits are:

- **Stacker cranes:** these carry out the work of front-loading forklift trucks. They pick and place the products, travelling the aisle from one end to the other. Stacker cranes can perform both simple and combined cycles. Combined cycles can offer great time savings: after a “trip” to deposit an item, the stacker crane picks another item before returning.
- **AutosatMover:** is the modular automatic storage system for high density. AutosatMover consists of a Mover, the main shuttle running on tracks perpendicular to the storage aisles, and Supercap ES, the satellite on board the Mover, which automatically moves along the shelves to deposit and pick pallets quickly, ensuring greater operating accuracy and safety. The AutosatMover system can take full advantage of the warehouse space.
- **Miniload:** works like a pallet stacker crane, but is designed for storing small parts. It is the most suitable system for handling cases, containers and trays. The Automha Miniload makes preparation of small item orders faster and more efficient.



**AUTOMHA IS THE STRATEGIC PARTNER YOU ARE LOOKING FOR**

Based on experience gained over the course of more than forty years, Automha analyses: A, B, C rotation, data analysis, system flows and schemes, return on investment, workloads. Based on these analyses, Automha designs and develops the best solution that reflects the customer’s growth expectations.

# Which storage solution is right for your business?

The available space plays a fundamental role in the design of an automatic warehouse. That is because it directly affects the options for organizing an efficient goods storage and handling system. The main points to consider are:

- The internal or external area available for the warehouse;
- The types and quantities of load units to be stored;
- The warehouse flows.

## THE WAREHOUSE AREA

The terms internal or external area refer to the space available to create the warehouse. It can be external, and therefore self-supporting, or internal (or partially internal), either inside an already existing building or self-supporting.

## LOAD UNITS

Any storage system is based on how the load units are defined. The various Handling Units, i.e. the pallets or universal bases, must be identified according to their compatibility with forks, stability and integrity; the dimensions and weights of the Load Units and any possible overhang; the reference quantities to be stored and the maximum quantities in the LUs; the presence of processing batches; and the types and quantities of the LUs themselves.

## WAREHOUSE FLOWS AND SCHEMES

Warehouse flows means the movements that the load units make within a system. The goods pass through a warehouse briefly; they enter and exit continuously. This temporary aspect refers to the time required for active goods management (handling, storage, consolidation etc. phases), as well as the time used for passive goods management (the time during which the goods remain stationary or stored waiting to be managed).



The flow is not always linear; the goods do not simply arrive, transit and then exit in all warehouses. On the contrary, much more complex situations can arise.

The flow of materials or goods can be developed in various ways depending on the product to be moved or the type of system in which they will be stored.

### SIMPLE FLOW

Occurs when the same load units sent by the supplier are supplied without the need for splitting. The goods enter the warehouse, go through the storage phase and pass on to the consolidation phase before they are put back into circulation.

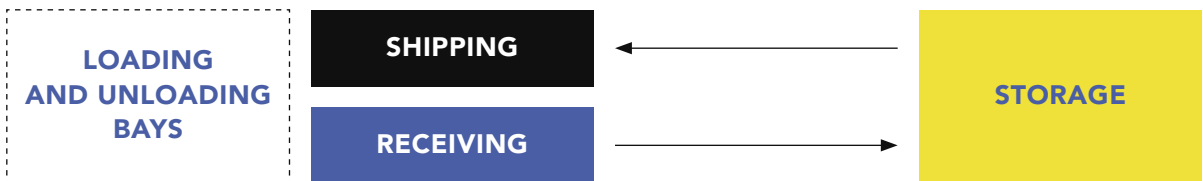

### MEDIUM FLOW

This is the type of flow in warehouses in which simple or combined picking is carried out. In this case, after the receiving phases, the goods move to a main warehouse, where they are sorted for shipment or directly to the consolidation area.

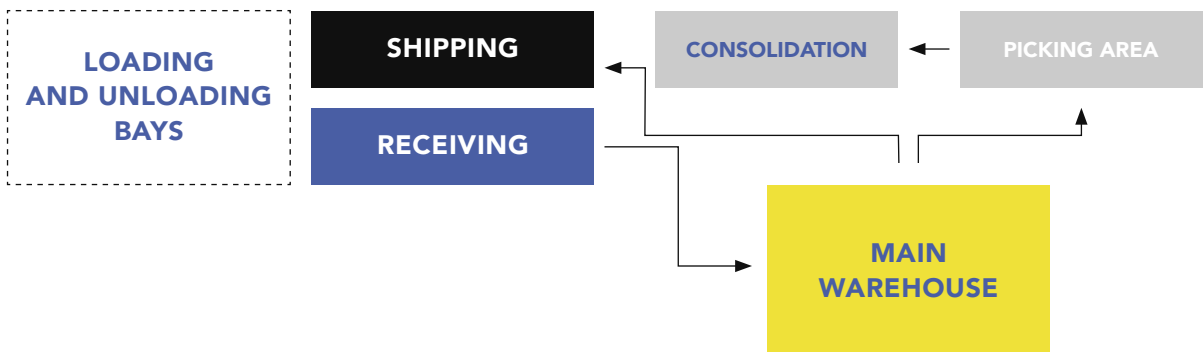

## COMPLEX FLOW

This is used in systems that usually have intermediate handling areas and that can require more than one operational procedure with flows of a certain complexity.

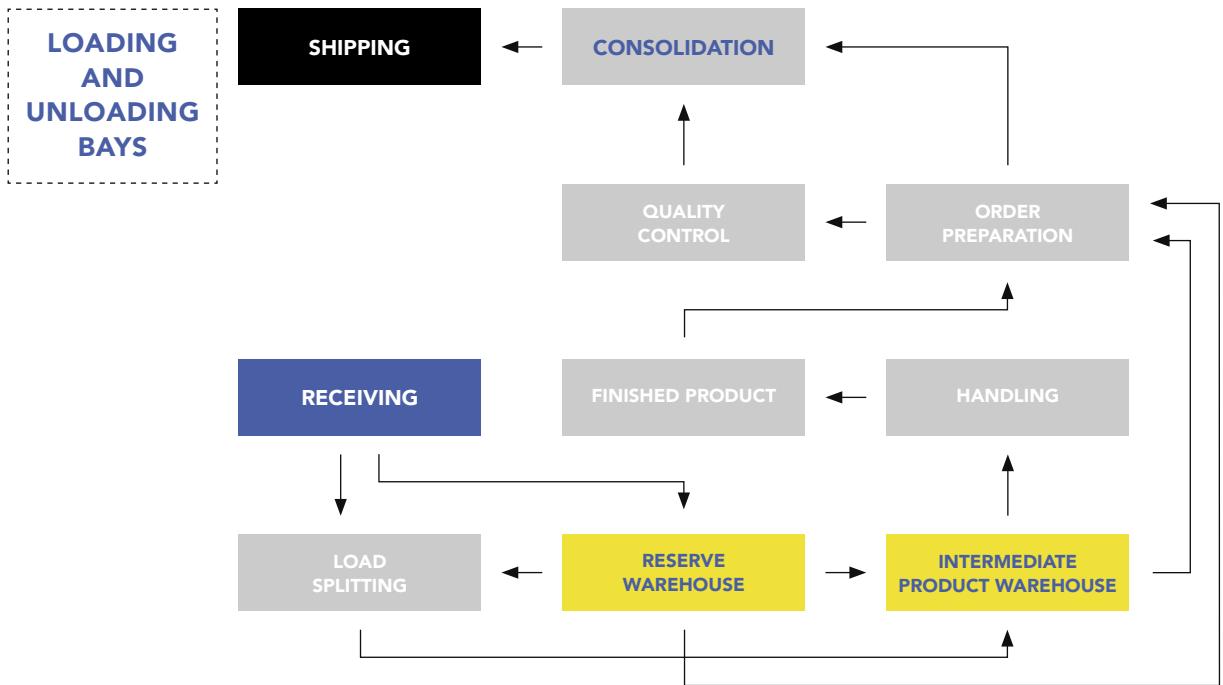

## PRODUCT ROTATION

A decisive factor that conditions the logistic flows is the demand for each product type. The most popular items must be placed near the loading and unloading bays. The rotation indices are used to determine which articles to distribute in these areas. They indicate the stock turnover in the warehouse, and can be used to divide the goods into three categories:

**A**

### HIGH ROTATION

Very popular items that enter and exit continuously

**B**

### MEDIUM ROTATION

These enter and exit often, but in smaller quantities than Class A goods

**C**

### LOW ROTATION

These are load units that remain the longest in the warehouse and are not very popular

The relative rotation index values are a tool for double-checking the 80/20 theory, according to which 80% of sales are concentrated on 20% of products, while the remaining 20% of sales are distributed among the remaining 80% of products.

Considering both these factors, the flows must be treated differently depending on whether the rotation type is A, B or C.

It is sometimes better to group products by storage system in an attempt to make the most of the available space. In other situations, however, system agility and time savings are more important. Where feasible, the two factors will be combined.



**AUTOMATIC WAREHOUSE  
FOR STORING SHOWER  
CABINS, DUKA, ITALY**

**DO YOU NEED COMMERCIAL, TECHNICAL OR SERVICE INFORMATION?  
DO YOU WANT TO OPTIMIZE YOUR SUPPLY CHAIN, OR THE FLOWS  
AND SCHEMES OF YOUR WAREHOUSE?**



**THE AUTOMHA TEAM OF PROFESSIONALS  
IS AT YOUR DISPOSAL FOR ANY REQUEST.  
OUR EXPERTS CAN PROVIDE COMPREHENSIVE  
SUPPORT FOR EVERY LEVEL OF YOUR ORGANIZATION.**



# AUTOMHA SOLUTIONS

# 1. AUTOMHA SOLUTIONS

## 1.1 Pallet warehouses

### MULTI-DEEP PALLET STORAGE SOLUTIONS

**Automha systems** are designed to provide specific solutions for each storage sector and answer various needs relating to different types of goods, such as size, performance and storage methods, picking, and operating conditions.

**Multi-deep storage maximizes warehouse space efficiency.** The obvious advantage of this type of storage is the elimination of a large proportion of access corridors, so that the usable volume of the warehouse is exploited to the maximum, thereby reducing costs related to the ratio between area occupied and usable capacity.



# 1. AUTOMHA SOLUTIONS

Multi-deep storage solutions may be **automated** or **semi-automated**:

## Automated solutions

In 2010, the world of automated storage saw an important revolution thanks to the arrival on the market of **AutosatMover**, the **modular storage** system suited to all industrial sectors. AutosatMover is composed of:

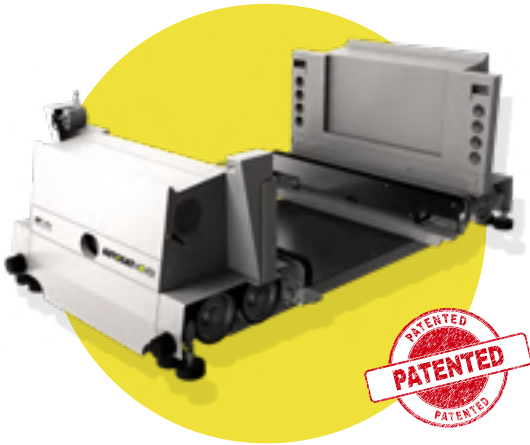

**Mover**: the parent shuttle that runs along **rails lying perpendicular to the storage lanes**, which is powered by a busbar.

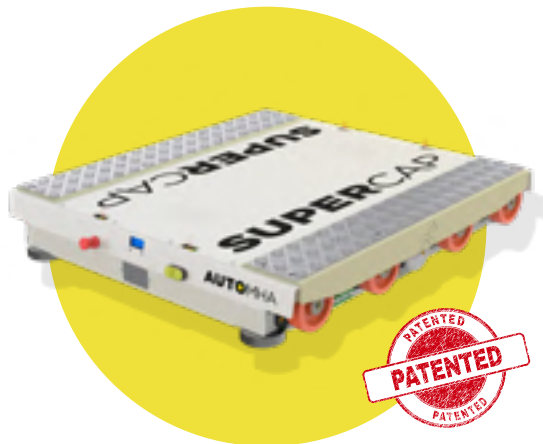

**Supercap ES**: the **satellite** on board the parent shuttle, which performs pallet storage and retrieval operations in the storage lanes based on commands issued via WI-FI from the Mover shuttle.

Based on the customer's cycles, the AutosatMover system allows for various configurations. The one generally used is an **AutosatMover for each storage level**.

This allows the potential of the system to be fully exploited, reducing pallet storage and retrieval times.

The various levels are served by high-speed storage lifts that transfer the pallets from the conveyors on the ground to the level required. The system also enables pallets leaving the automated warehouse to be transferred to the retrieval and shipping areas. This is achieved thanks to special buffer bays where the load units await the arrival of the machines without obstructing warehouse maneuvers.

Autosatmover is the ideal solution for all industries that need to develop automated systems that maximize warehouse space efficiency, thereby optimizing management costs, and which have to perform a high number of warehouse handling operations.



# 1. AUTOMHA SOLUTIONS

**Automha WMS software, AWM.20** (AWM - Automha Warehouse Manager) manages the entire Autosatmover system.

In addition, the parent vehicles are equipped with automapping: the parent vehicle and satellite combination is fully transparent and enables the remote parameterization of all on-board sensors and actuators.

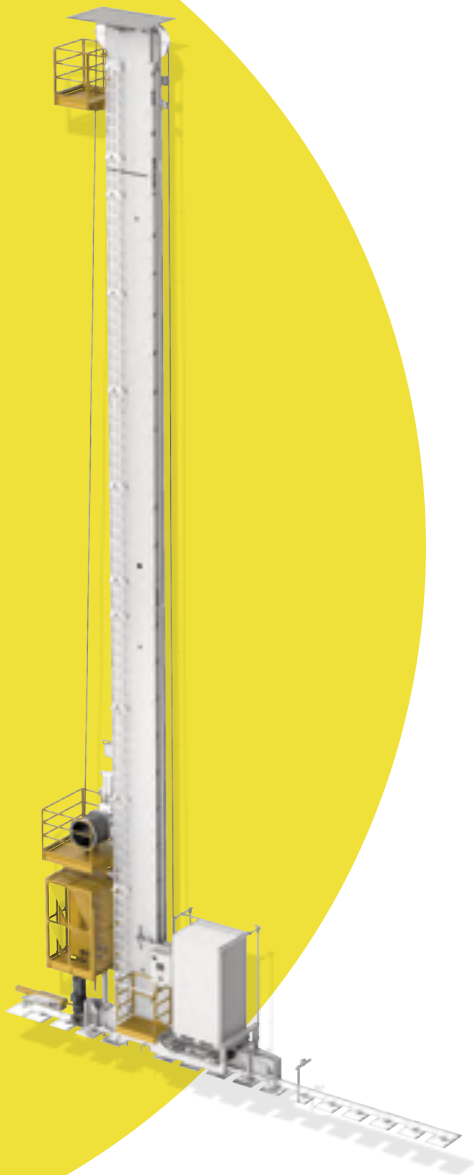

## **Stacking crane with Supercap**

Multi-deep storage can also be managed with **the combination of satellites on board a stacking crane**. Automha has equipped Supercap ES with supercapacitor technology, which overcomes the problems typically associated with battery-powered systems.

Unlike batteries, the supercapacitor has the advantage of **recharging times of 7 seconds**, **has an almost infinite lifespan**, requires **no maintenance** and is able to operate without losing power at up to **-30°C**.

The satellite is equipped with equipment for identifying the condition of the racks, and render in graphic format, using WMS, any inconsistencies encountered during its missions, during inspection tests but also later when the system is operating (remotely).

In both cases, Automha's Supercap ES offers a series of advantages:

- brushless motors for both traverse and lifting;
- impressive kinematics;
- full compliance with safety regulations;
- low maintenance;
- predictive maintenance;
- stand-by mode during maintenance.



**Lane rescue device:**

**Rescue Rover**

Automha has always been safety conscious, particularly when it comes to its warehouses and workers, and for this reason has patented the Rescue Rover, a carrier to be used by an operator trained to recover a satellite that has stopped in a lane, provided that the machine:

- is not blocked by external obstacles that prevent its movement;
- the instructions for using Rescue Rover have been applied.

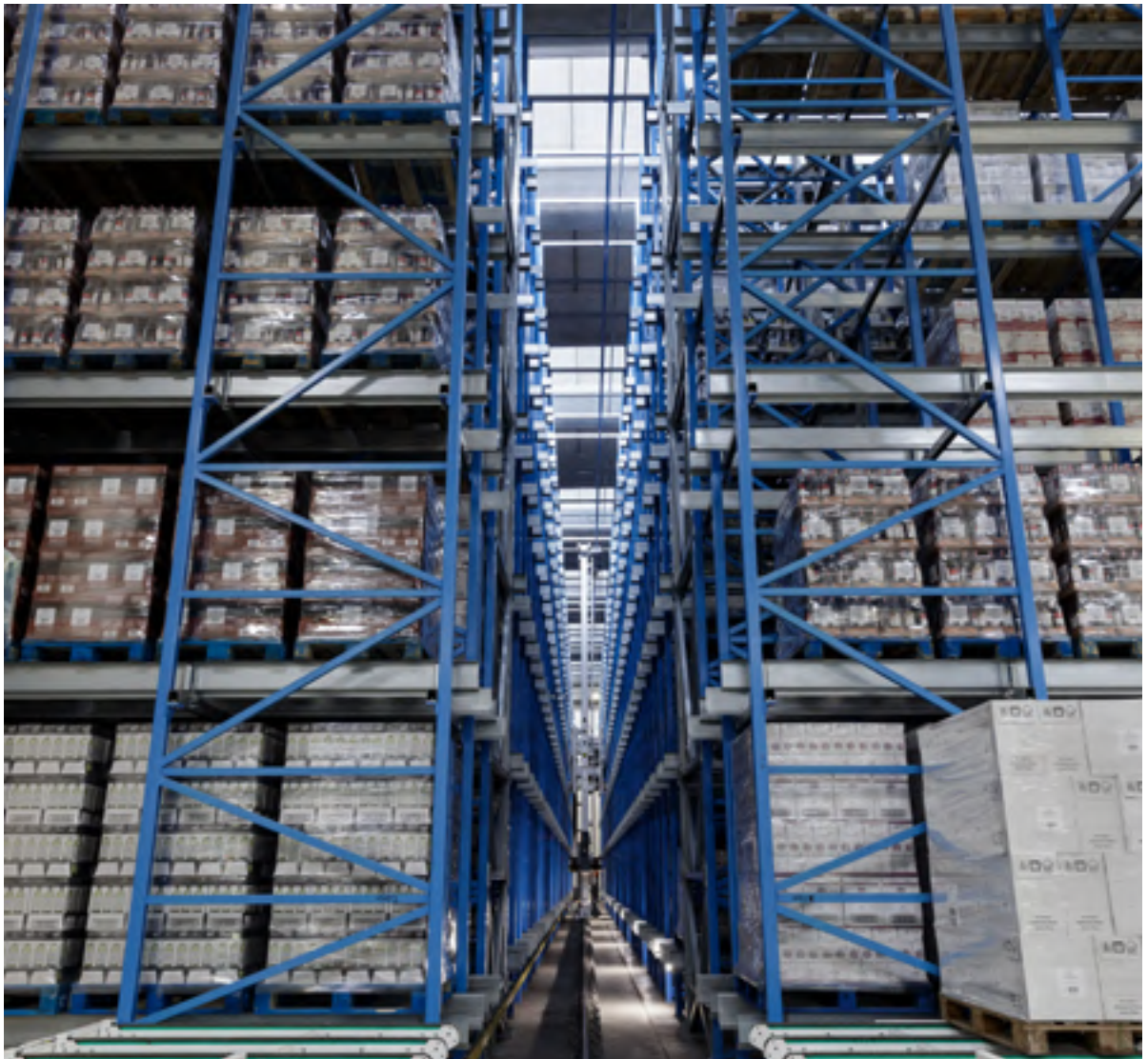

# 1. AUTOMHA SOLUTIONS

## Semi-automated solutions

**Autosat** is the perfect solution for the **high-density multi-deep storage of pallets**. This system is able to manage the storage of any product type positioned on pallets and containers inside the warehouse.

Autosat is suited to any shelving racks that can be used with conventional fork-lift trucks, and operates among the racks according to **FIFO** (First In - First Out) or **LIFO** (Last In - First Out) methods.



Autosat is equipped with a special **removeable lithium battery** weighing 9 kg with a discharge time of up to 10 hours, and is controlled by multifunctional radio control.

The level of stock saturation of drive-in warehouses served by Autosat reaches 90%, guaranteeing maximum storage capacity without damaging the goods and the metal shelving racks.

Autosat can be used to perform various methods, from the more usual FIFO/LIFO to Case Picking, and to the more traditional 80-20 rule.

Autosat operates at temperatures from **+45C°** to **-30C°** without any change in performance.

Autosat can be customized with:

- **WiFi: communication with hand-held devices, AGV and warehouse management systems.** System management is enhanced with the installation of LOG software, which in real time provides the operator and warehouse WMS with information on the status of the warehouse and goods inventory;
- **Inox Technology:** made entirely of **stainless steel and waterproof**, making it the ideal partner for the **dairy and food sector** where high standards of hygiene require advanced technology that meets the strictest legislation;
- **ATEX:** areas with **potentially explosive atmospheres are no obstacle.** The ATEX version of Autosat in compliance with the **ATEX 2014/34/EU Directive** and according to the **EN1755:2015** standard guarantees total safety and reliability.

**Automha is the first and only company in the world to offer solutions for ATEX environments.**

### Lane recovery device: Autoservice

This is the Autoservice manual safety platform for **recovering Autosat satellites** in lanes, in the event of a fault or ongoing maintenance. Easy to use, EC and TUV certified, the customer's extraordinary operations can be performed in complete autonomy.





# 1. AUTOMHA SOLUTIONS

## PALLET STORAGE SOLUTIONS IN SELECTIVE MODE

### Single, double and triple depth

Automha stacker cranes are also suited to warehouses that require **selective storage of the load unit**.

For this need, Automha proposes handling using a stacker crane with telescopic forks for retrieving and positioning loads in the shelving units. This system is able to support loads weighing between 50 kg and 2500 kg.

The pallets can be stored on single-, double- and triple-deep racks, to optimize storage density in accordance with the handling operations required.

The stacker crane for double- or triple-deep storage enables a **good balance to be achieved between storage capacity and an increase in hourly cycles**.



The operating methods can be divided according to whether they involve a **single cycle or combined cycle**.

Automha stacker cranes run on rails equipped with an exclusive anti-vibration plate system and receive power for motion from bus

bars positioned on the ground; they can be applied in a wide variety of industrial sectors.

**Automha machines can be used in both new warehouses and existing warehouses.**

The structure of the warehouse need not be changed.

### The advantages of our machines

- **Costs savings:** Automha stacker cranes deliver energy savings, and the regenerative energy generated by electric motors on the machine axles is introduced into the warehouse power supply;
- **Silent** operation;
- Management of **multiple load units:** pallets of any size, metal or plastic containers, trays, frames, rolls and reels, long items, motor vehicles, finished products;
- **Adaptability** to existing structures;
- **Advanced technologies** incorporated in the system;
- Possibility of integrating future developments in technology;
- Performance unchanged at temperatures from **-30°C to +45°C**;
- Heights **up to 40 m**;
- Possibility of **customizing** the machine according to the features of the load unit.

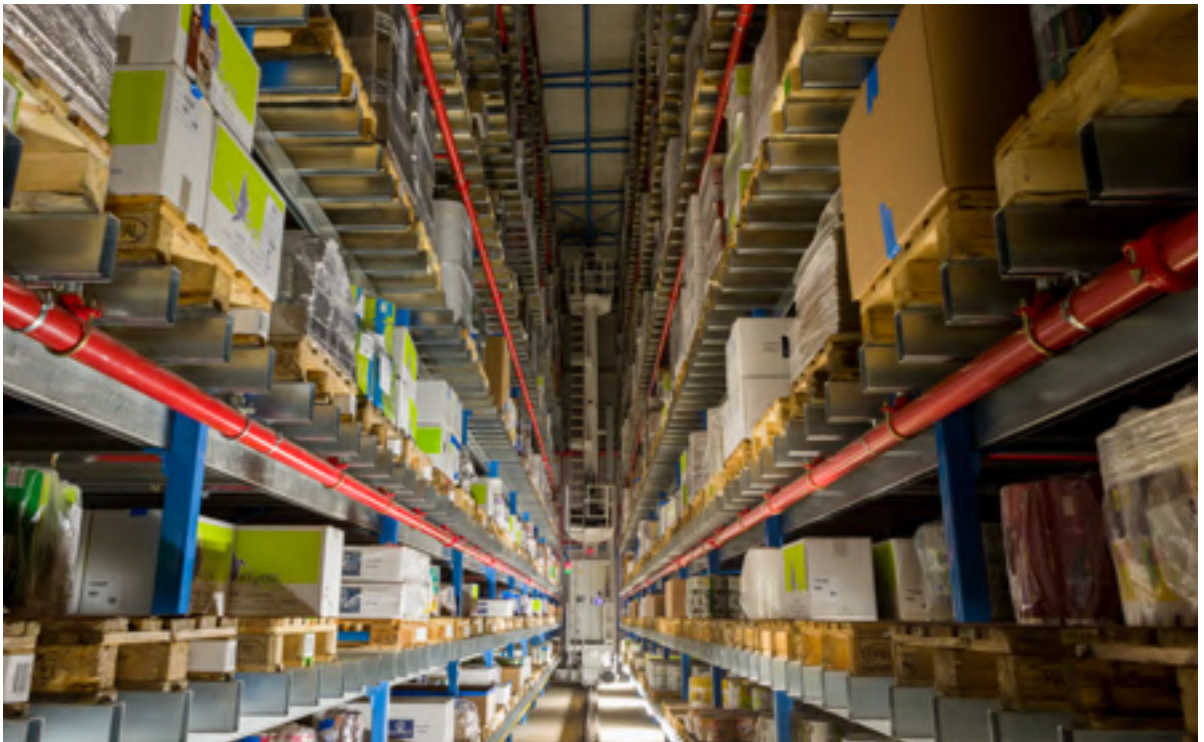

# 1. AUTOMHA SOLUTIONS

## SOLUTIONS FOR HANDLING WITH THE ASSISTANCE OF ANTHROPOMORPHOUS ROBOTS

### Layer picking

Customers' requests, in terms of the variety of goods, personalization, freshness and speed of delivery, are becoming increasingly demanding.

**Same-day delivery** is now a frequent request. The preparation of orders and palletization are extremely expensive processes and contribute to 60% of the total operating costs. The many and growing needs of today can be met only with a **high level of automation and with systems equipped with self-learning capabilities.**

Automha meets companies' emerging needs by integrating its systems with **layer palletizers** that can be adapted to **various box and pallet sizes and layouts** according to the needs of customers. These robots, in fact, provide greater flexibility when configuring layouts forming pallet layers.

The palletizer can be constructed according to the principle of **layer grouping** and transfer using a traverse platform with load stacking from above.

In addition, our many years' experience in handling systems guarantee that a system is built with high-performance incoming box transport systems, devices for box rotation to form layers according to the method requested, traverse tray lifting systems for layer overlapping.

Other types of robots for palletization, already tested by Automha in its plants, are those with suction grips. **Robots of this type can be used to pick up the product, wooden pallets and layer dividers.**



## Package handling

Automha is able to design solutions that combine **palletization and depalletization of layers in a single work phase.**

Depalletizers are **robots that unload packages or products from pallets** so that they can be handled without human intervention, thereby saving time and resources. There are different types of depalletizers, which vary according to the functions they need to perform, but above

all according to the type of material or products that need to be unloaded from the pallet on which they are stored.

Automha installs all types of depalletizers in its systems, adapting them to the functions they need to perform according to customers' specific requirements. Automha assists its customers in the selection of available technologies, directing them towards the most suitable logistical solution.

### The advantages of our machines and our systems

- Our robots guarantee **100% precision**;
- **Guaranteed efficiency**: in the long term, fully automated processes are extremely competitive;
- Possibility of palletizing even on **pallets positioned on the ground**;
- **Extremely reduced volumes**, which enable installation even in production facilities where the positioning of another type of palletizer would be otherwise impossible;
- Robots are able to perform **risky tasks** which in the long term may be hazardous to people's health;
- In the absence of personnel, other robots can be added to **increase productivity**;
- The anthropomorphic robot palletizer/depalletizer comes complete with **safety devices** according to current international legislation.



# 1. AUTOMHA SOLUTIONS

## 1.2 Warehouses for boxes, trays

### ORDER PROCESSING, E-COMMERCE

The continuous developments in retail sales dictated by e-commerce, together with the changing demands and expectations of customers has radically altered warehouse logistics requirements.

Automha has designed a high-performance system that answers the needs of e-commerce, distribution centres and other situations: **PeakMover**.

With PeakMover, Automha specializes in the **automated handling and storage of cardboard and plastic boxes**.

The PeakMover solution satisfies the needs of all customers that require **very rapid deliveries**, and have a wide variety of storage units - typical problems of e-commerce and omni-channel commerce. **PeakMover incorporates innovative systems, intelligent software and advanced technology**, which guarantee optimum performance and low maintenance costs.

PeakMover guarantees fast, organized handling in the warehouse, facilitating goods receipt and shipment operations, and can be used in all sectors that require the storage and management of boxes with **a high incoming and outgoing flow and at temperatures of up to -30°C**.

PeakMover is an efficient asset for all companies that aim to be truly competitive in serving customers.

PeakMover is available in two versions:

- **PeakMover Standard**: fast, accurate, high-performance and innovative in terms of construction and technology;
- **PeakMover Plus**: with the same features as the Standard model but larger dimensions and Load Unit capacity.

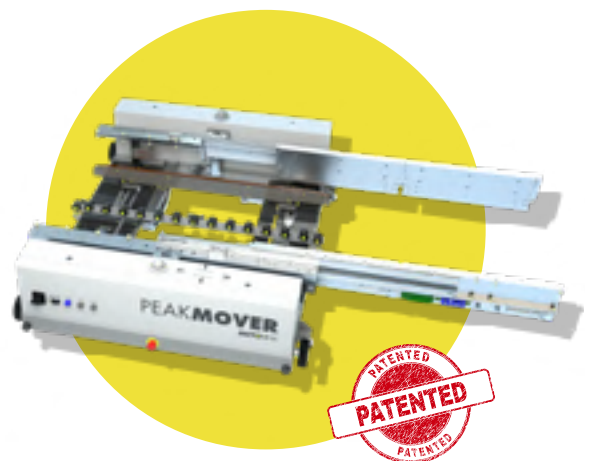
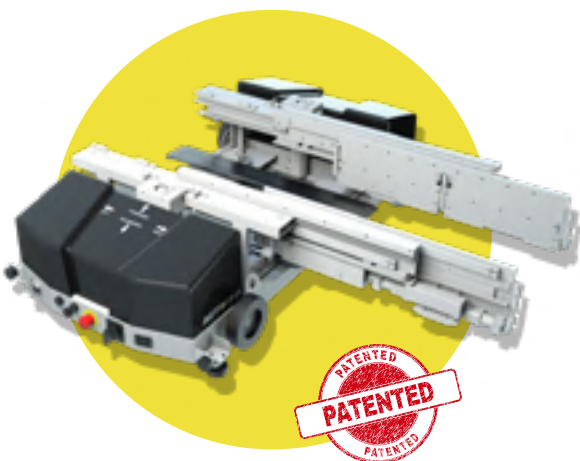



### Why choose PeakMover?

- **Compact dimensions;**
- **Fork extensions** for multi-deep storage with better performance than other similar machines;
- **Greater storage density** on shelving racks;
- **Versatility:** fork spacing can be changed so that the machines are able to transport packages of varying dimensions;
- Pickup equipment powered and controlled using **wireless solutions;**
- Greater **sturdiness;**
- Low maintenance **costs;**
- **Rapid recharging** thanks to supercapacitor technology.

PeakMover can be incorporated in pick-to-light, put-to-light and voice picking systems for the textile, manufacturing and mechanical/electronic sectors, as well as for refrigeration chambers, chemical and pharmaceutical industries and logistics centres.

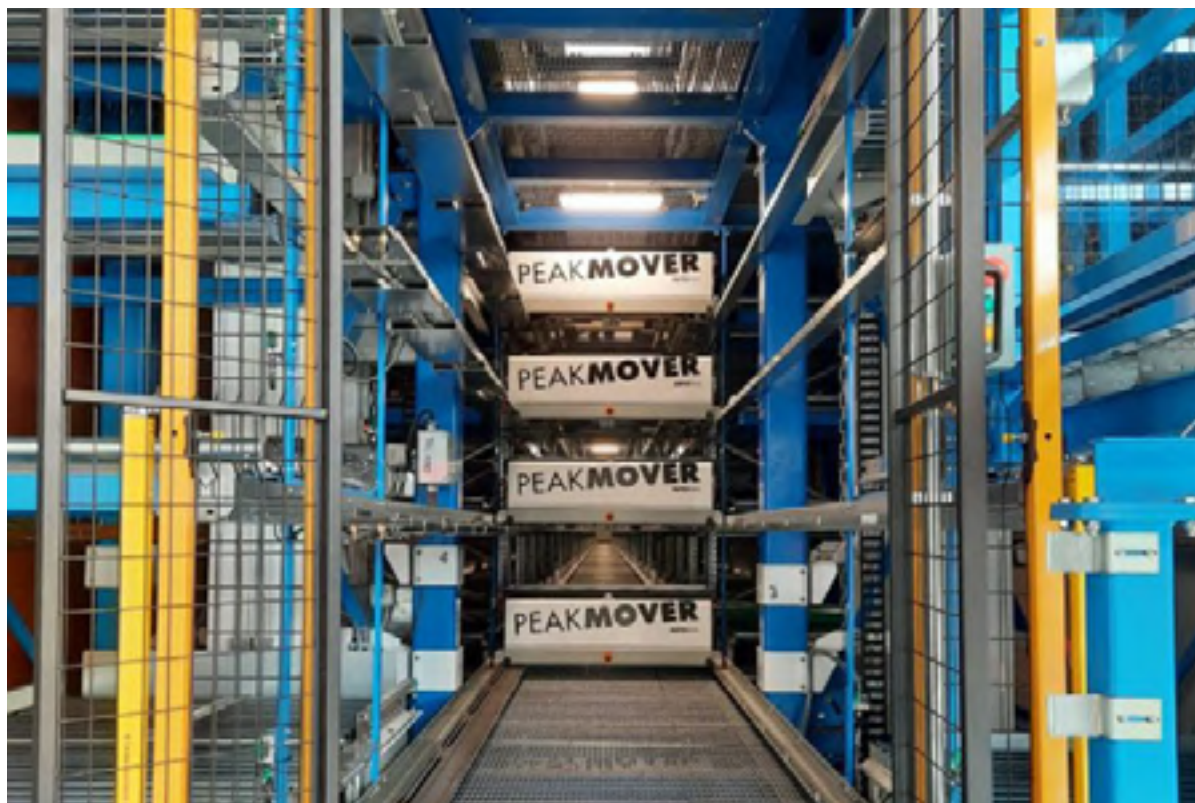

# 1. AUTOMHA SOLUTIONS

## PRODUCTION

The fully automated **Miniload** warehouse is the perfect solution for all situations with **high productivity and for warehouses supplying production lines**.

Miniload is a fully automated system suitable for handling any type of box or tray.

**Automha's Miniload systems are recommended for warehouses with high picking rates and load units with a maximum weight of 300 kg.**

The Automha Miniload, however, can, with a few modifications, achieve greater capacities.

The warehouse comprises a **central lane** along which a stacker crane runs, which serves shelving racks on both the left and right of the path taken by the machine.

The **boxes and trays** are placed in their positions on the shelving racks. **Conveyor circuits** transfer the load unit to picking stations and once the operation has been completed they are automatically transferred to the stacker crane for positioning. All Miniload operations are performed rapidly and with full computerized management.

The entire system is coordinated by AWM software, which records movements and the positions of the load unit in the warehouse and manages operating flows.

The reliability, speed and accelerations of the Miniload stacker cranes, together with modularity of the shelving racks and interface software functions make these systems **the most efficient and productive in the sector of storage with automatic picking**.

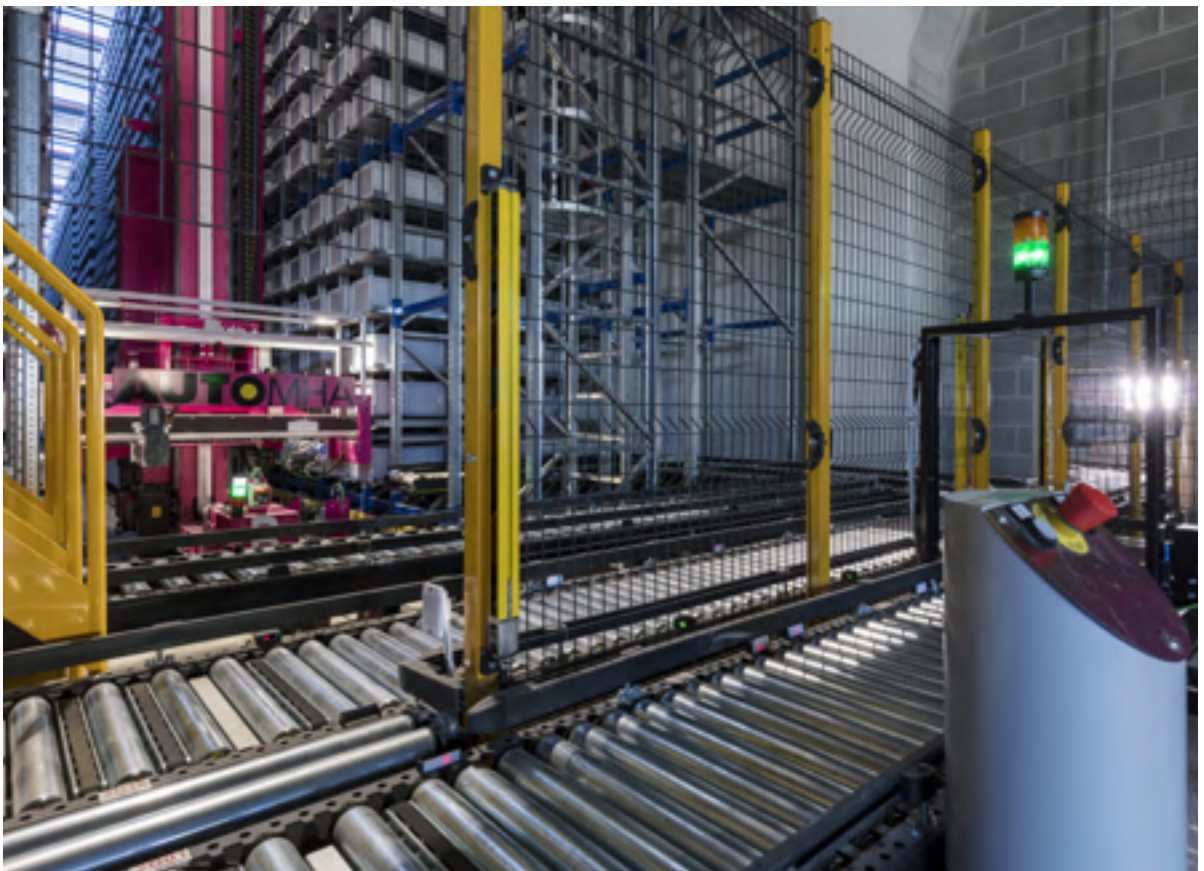

## The advantages of our machine

- **Cost savings and energy savings:** during the stages of cart traverse deceleration and descent, the motors generate energy, which via power drives is returned to the factory's electrical power grid, resulting in substantial cost savings;
- **Silent operation;**
- **Stripped-down design:** the machine consists of fundamental parts that are easy to identify and maintain;
- Unit weight transported of **up to 300 kg:** with unchanged cycles compared to classic miniloads;
- **Management of different load units;** trays, cardboard boxes, plastic boxes of different measurements and heights; load unit personalization on request;
- Suitable **for all sectors:** food, electronic, chemical, pharmaceutical, fashion, textile, manufacturing, mechanical and cosmetics;
- Possibility of installation at **low temperatures.**



# 1. AUTOMHA SOLUTIONS

## 1.3 Vertical warehouses

### LONG ITEMS, MOLDS

Heavy items and articles with varying measurements are often a barrier to well-planned warehouse logistics and efficient utilization of spaces.

In the case of long items, molds or heavy materials, handling may prove to be difficult, resulting in higher costs in the long term.

These problems are overcome by using the **HeavyTower automated vertical warehouse**.

HeavyTower is an automated vertical storage system specially designed for customers that need to **store long items, molds and heavy materials, which guarantees capacities of up to 5000 kg per floor**.

HeavyTower has been designed for all those manufacturing firms that want to make use of all the vertical space available, thereby increasing storage capacity considerably and cutting costs associated with the purchase or rental of other spaces.

Furthermore, HeavyTower is a people-friendly machine: it perfectly combines its vertical aspect with the principle of **"goods to person"** picking and, thanks to the latest generation lifts, always delivers the goods to the warehouse worker at ground level. The machine is equipped with a communication interface that can easily be connected to devices and software of any type rapidly and efficiently as required by Industry 4.0.



HeavyTower can be configured as an **inter-operational buffer** and used alongside cutting and production machines. Automha's **HeavyTower is the ideal solution for storing steel bars and profiles, tubes, heavy accessories, semi-processed items, parts, molds and large items in general.**

The HeavyTower vertical warehouse is available as a **mono-tower, double-tower** or **multi-tower** storage system

Using a **latest generation extractor**, the lift transfers the load units from the storage positions to a transfer system, and then from the latter to a work bay within the transfer area and finally to an operator at the correct ergonomic height.

The vertical system can be equipped with several operator stations, both to the front and the rear of the storage system.

The operator area or picking/put away bay is designed in such a way as to allow the operator to **load and unload entire packages** of heavy material using a forklift truck or other system.

The control system, with **touch screen** on the operator terminal, controls storage operations which can be in manual or automatic mode.

For HeavyTower systems operating separately, a **multi-warehouse system** can be created with overall control. A more complex process to obtain a controlled system is also possible.

### Advantages of our system

- "**Goods to person**" principle;
- Efficient use of **space**;
- High-capacity storage in a **small area**;
- Easy **material handling**;
- Excellent **material protection**;
- **Internal and external** installation;
- Easy **control and maintenance** of the system;
- Equipped with all required **user safety devices**.

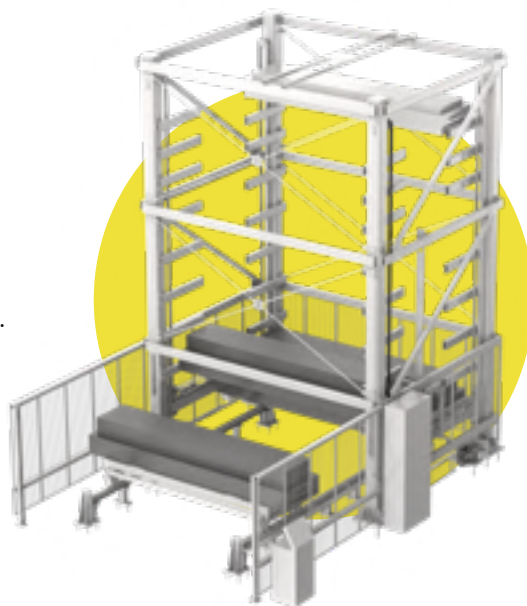

### 1.4 Warehouses in the textile and synthetic fibre sector

Over the course of the years, Automha has earned the reputation of being one of the world's best providers in the area of automated storage systems for the textile sector.

Automha's continuous search for solutions that fully satisfy customers' needs led to the creation of the **world's largest automated warehouse for textile rolls**.

The load units stored in the textile industry may have a longitudinal shape, such as fabric rolls or reels, which are generally stored in crates or boxes.

Automha provides customized solutions for handling and storage of both types of load unit.

#### SWATCHES

The handling and storage of fabric rolls requires specific technical precautions due to their cylindrical shape and form (they are often soft and with or without an internal support core).

The automated warehouse for fabric rolls is required to perform the following operations:

- **receipt, storage and shipment of fabric rolls from various external factories** and/or suppliers; in this case the automated warehouse acts as a logistics centre for large weaving mills or large commercial companies in the sector;
- **receipt, storage and internal distribution of fabric rolls from various suppliers** to the end user's production lines; in this case, the automated warehouse acts as an internal supply centre for the production of large packaging firms;
- **transfer of rolls to cutting machines** (picking: automatic or manual) and return of the roll after cutting (filling: automatic or manual).

### Bin warehouses

There are two types of bins: **multi-layer**, more conventional, or **single-layer** and customized, designed especially for Automha's customers. The rolls are placed in the bins, which may be single-item or multi-item bins. Once the parameters are recorded, the container is stored and retrieved automatically.

In the case of bins and containers, Automha recommends installing single-deep stacker cranes.

### Warehouses with baskets

The company has acquired over the years significant know-how in this specific sector,

patenting a **high-density fabric rolls storage system**.

This system combines stacker cranes with forks with a special storage system and automatic sorting.

### Selective warehouses

Usually used for handling pallets, Automha has designed solutions with stacker cranes with forks for the textile sector. These stacker cranes are fast and feature special **forks for the retrieval and selective handling of a single roll**. This patented solution has been selected by companies worldwide.

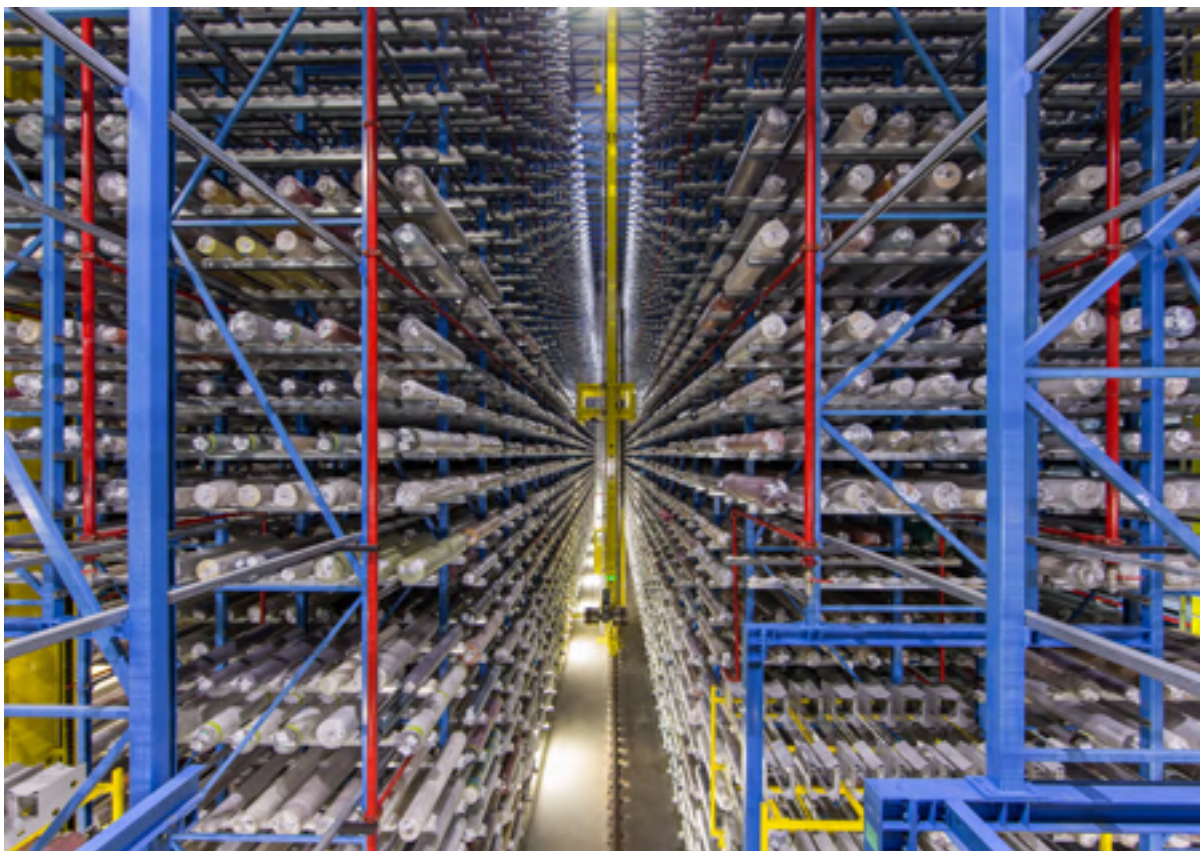

# 1. AUTOMHA SOLUTIONS

## REELS

The installation of an automated system for collection and palletization of fabric reels can make a textile company truly competitive within its market.

The automated system, which sometimes interfaces with the production line, enables the **monitoring of the production cycle and the product in the warehouse in real time, as well as reducing costs for labour and production downtime considerably.**

Storing reels of yarn or other synthetic material requires certain precautions to ensure that they remain in good condition and ready for use.

The storage solutions proposed by Automha are:

- **cardboard boxes** positioned on pallets (DTY, POY, FDY) if the product is sold by volume. The storage configuration can be selective or multi-deep with single-item accumulation channels, specific batches and specific class. They are generally positioned in selective warehouses where Miniload booster machines or Peakmover parallel machines operate;
- **metal and plastic boxes**: stored in selective warehouses primarily for picking activities.





## 1.5 Special warehouses

Automha is well known in the sector as the **"tailor" of automation**: it creates solutions tailored to each customer, to meet any storage requirement.

Certain examples that demonstrate Automha's high level of technology are the construction of warehouses for storing luxury vehicles, fully automated vertical greenhouses, and the consequent need to develop machines and software for these specific contexts.

This highlights the versatility and level of **know-how** that Automha is able to offer the market.



The background is a solid dark blue color. It features several overlapping geometric shapes in a lighter shade of blue. There is a large circle in the upper left, a smaller circle overlapping its bottom edge, and a horizontal rectangle at the bottom right. The text is centered in the middle of the page.

# HANDLING SYSTEMS

## 2. HANDLING SYSTEMS

### 2.1 Automatic

#### HANDLING

Automha designs, produces and installs **automated transport solutions** that improve productivity and reduce operating and labour costs. These solutions complete fully automated and complex storage systems or simply assist the management of manual or semi-automated warehouses. The modules comprising Automha's transport lines feature roller-, chain-, belt- or tape-drive stations, and can incorporate orthogonal transfer machines, transfer shuttles, lifts or other specially designed machines. These are solutions that can **operate in any industrial sector**, at any temperature and manage different load units.



## 2. HANDLING SYSTEMS

### The advantages of our solutions

- Identification by reading **bar code or TAG**;
- **Automatic check** of shape and weight;
- 3D display of load;
- **Packages aligned** in transit;
- **Load unit handled** in the receipt areas for subsequent processes;
- **Transport of goods** within the production processes;
- **Goods are directed** from the assembly processes to the packaging and shipping departments;
- **Restocking of goods in real time** from the warehouse to the picking or production stations;
- Restocking of goods at the filling stations (**refilling**);
- Automatic organization of shipping process orders;
- Full **traceability of goods**;
- Rightsizing of areas used for **materials handling**.

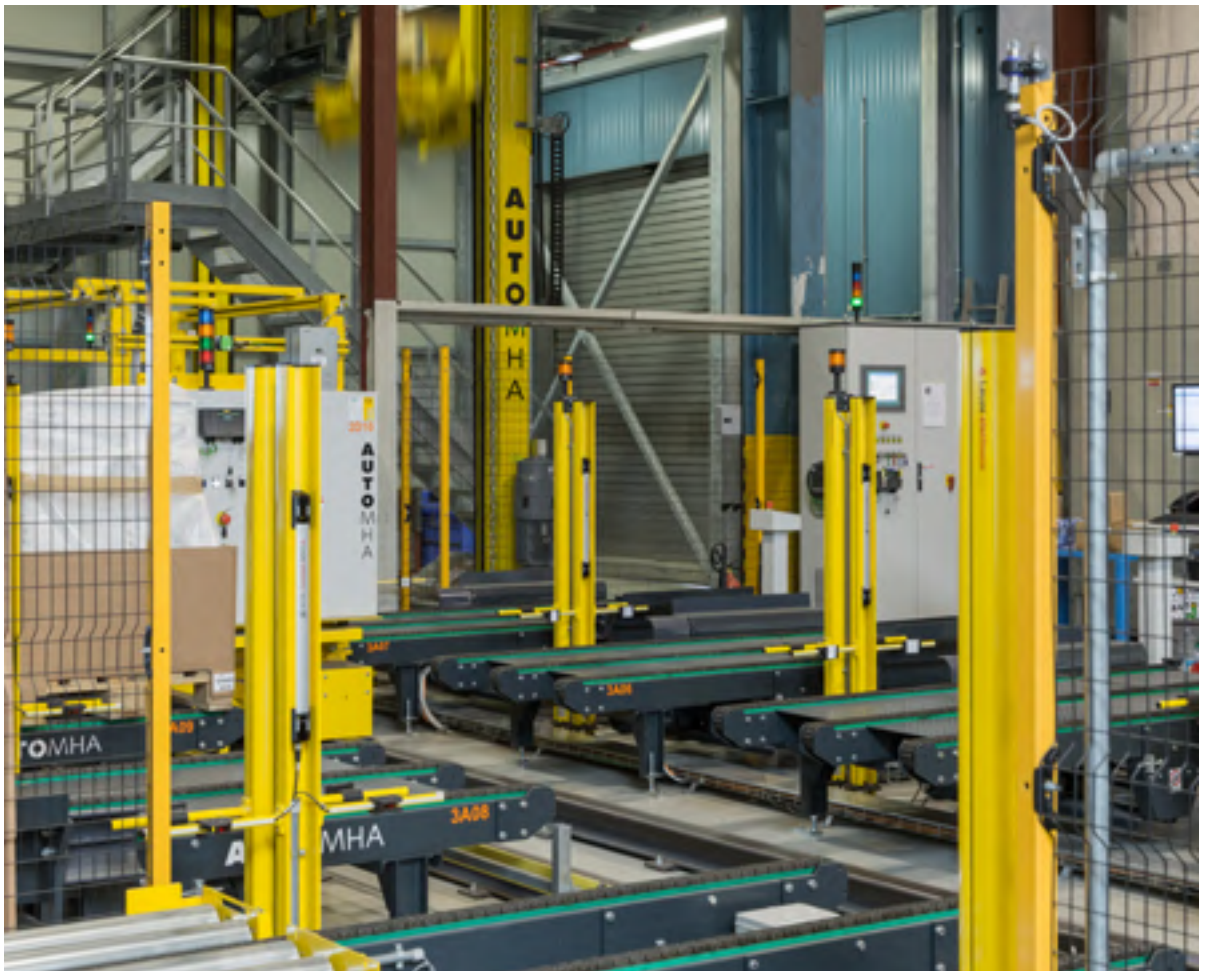



AUTOMHA

3A05

3A06

3A07

AUTOMHA

### 2.2 Manual

#### UNIFLEX

Automha is also specialized in the handling of specific packages in the logistics and shipping sectors.

The difference in weights and dimensions of goods handled in distribution centres requires the use of light conveyors that are easy to use and are maintenance-free.

Uniflex conveyors are the answer to any specific requirement, and are available in the models:

- **motorized rollers;**
- **gravity rollers;**
- **gravity wheels.**

The width of these conveyors varies from **600 mm up to a maximum of 900 mm**, making them versatile in adapting to the needs and types of load units handled.

These internal handling systems are designed to meet the needs of **goods transport in a practical, rapid way.**

Their success is confirmed by the many systems installed and by customer recognition.

These conveyors are portable, **expandible and extremely flexible.**

This helps to save valuable space when the conveyor is not in use and makes them easy to adapt to different applications.

Thanks to this flexibility, the conveyor can be positioned wherever needed and the **length and orientation changed** according to needs.

The structure is easy to move thanks to swivel wheels with brake, and the steel support with patented structural channel on complete conveyors provides greater strength.

Their capacity per linear meter is **150 kg.**

**Perpendicular legs** ensure that the weight is distributed evenly on the floor in a vertical line, for greater mobility and strength.

These products can be applied anywhere and are ideal for meeting different and changing company needs.



Vehicles  
Reversing

KESI XCL

AVR

IN FLEX



A large, light blue, semi-transparent number '8' is centered on a dark blue background. The number is composed of two overlapping circles, with the top and bottom circles being larger than the middle section. The word 'SOFTWARE' is written in white, bold, uppercase letters across the middle of the number.

**SOFTWARE**



## 3. SOFTWARE

### 3.1 AWM



#### WAREHOUSE MANAGEMENT SOFTWARE

AWM - Automha Warehouse Manager - is the warehouse management software used by the operator to communicate with the system via a series of screens to manage **introduction, loading, refilling and picking**.

Through AWM, the status of the system can be monitored and checked: the operator can manage handling operations via specific input boxes protected by a login system, which guarantee that the system is controlled correctly even in critical situations.

Automha software is the only WMS on the market that has the SCADA system incorporated. This permits immediate processing of data and instant usability by warehouse operators. The latest generation AWM is also available in versions for mobile phones and tablets so that even non-operators may analyze the KPIs.

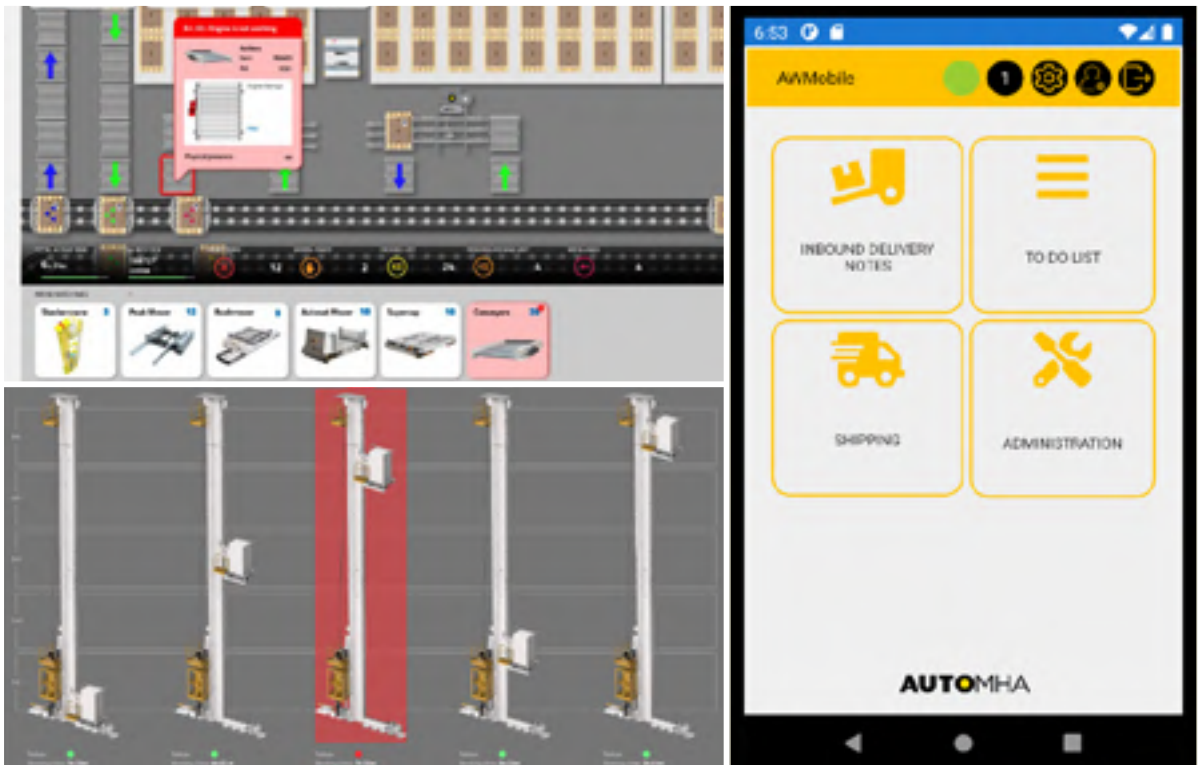

## 3. SOFTWARE

### HOW IT WORKS

AWM can interface with any customer ERP through exchange tables or Web Services.

Automha's team of software analysts **helps customers determine the most suitable** and balanced methods of achieving common goals.

Dynamic simulation supports analysis activities, giving the customer the absolute certainty that the warehouse and procedures are operating to optimum performance.

AWM is a **complete, standard and configurable software**, which has been developed on the Microsoft Server system, and manages three principal areas: the movement of flows (WCS), sending of pick lists and KPI analyses (WMS) and the connection with the factory ERP. Each verticalization is **tested and validated before on-site installation**.

#### The advantages of our solutions

The main features of the Automha's AWM system are:

- Web interface with zoom navigation in real time;
- Receipt and management of item codes;
- Management of production, picking and shipment;
- Management of inventory by item or batch;
- Management of sequences and shipping priority;
- Inventory updated in real time;
- Management of flows and planning correction in accordance with peaks in workload;
- Management of user profiles;
- Integrated safety;
- Manual management with tracking of operation and data;
- Management of KPIs via customized and customizable dashboard;
- Integrated SCADA with graphic display of machine and alarm status;
- Display in real time of machine components with their instruction manual and spare parts codes;
- Direct connection with Automha ticketing remote support.

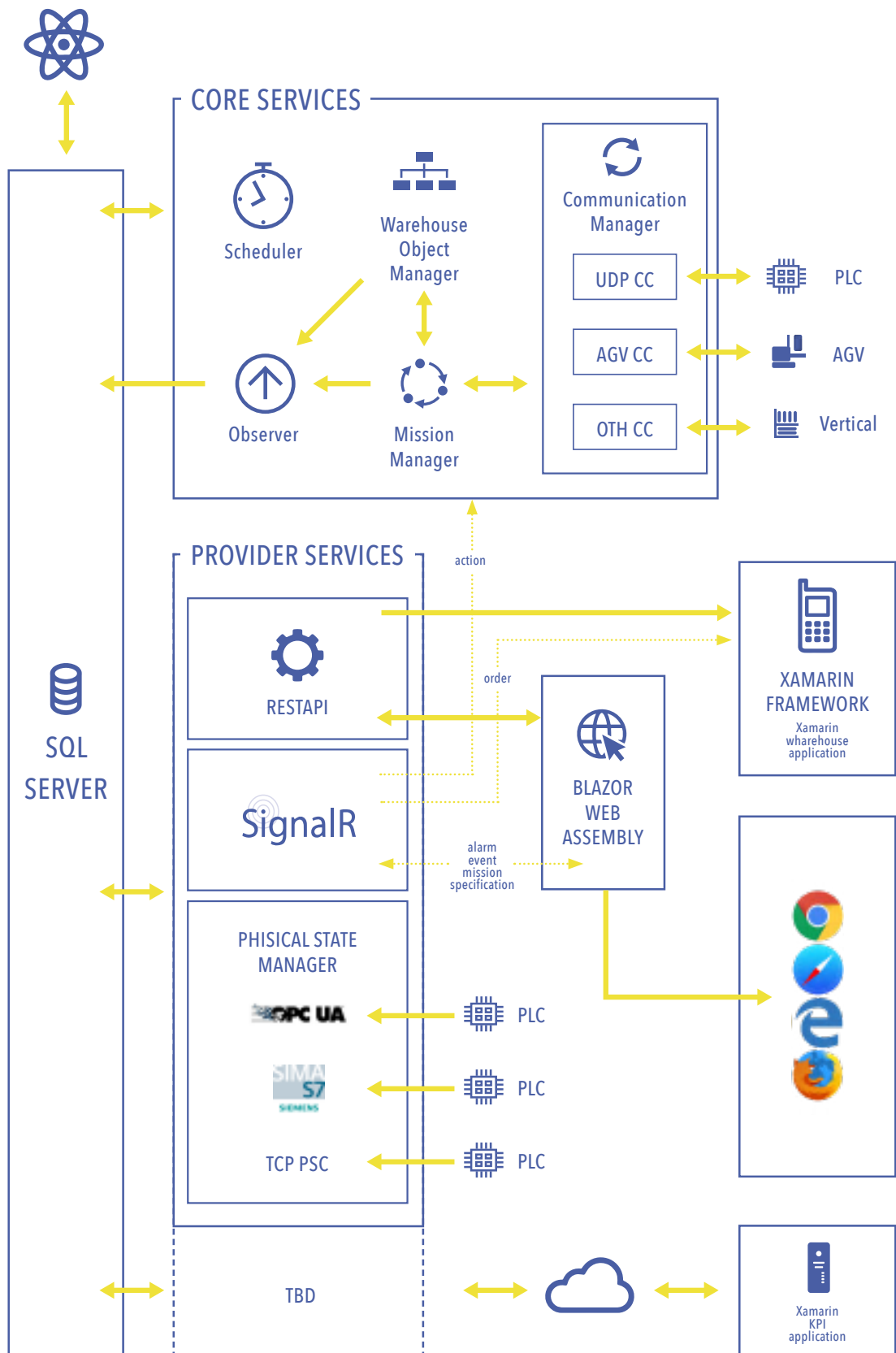

### 3.2 SYM



#### THE CERTAINTY OF A CORRECT CHOICE

Automha offers all its customers a **System Simulation and Virtual Commissioning service**, in other words the virtual reproduction of physical behaviour, via simulation software.

**3D simulation** is a video rendering of the system. Virtual Commissioning allows errors to be eliminated both digitally and virtually.

This allows the management process of products, particularly those made to order on the specific requests of the customer, to be streamlined, but not only: it can also be applied to standard products.

The use of Virtual Commissioning for products made to order arose from the need that when faced with a special request from a customer the specific dates at the start of work do not always remain unchanged until the end of the job.

This virtual approach makes it easier to **make changes to a project already underway, test them and check that they are truly effective, efficient and economical.**

The idea behind this approach is to connect a Digital Twin model of the actual system to the controller (**hardware in the loop**).

Thanks to this approach, a simulation model of the system is obtained, which the customer can analyze and get to know even before the plant is installed, thereby **guaranteeing optimal operation** and completion of the cycles requested. Virtual Commissioning allows mechanical and electronic control to be simulated; the model arising from this process is none other than a digital alter ego. A digital twin of the system, that can be analyzed and decisions made while the system is in operation.

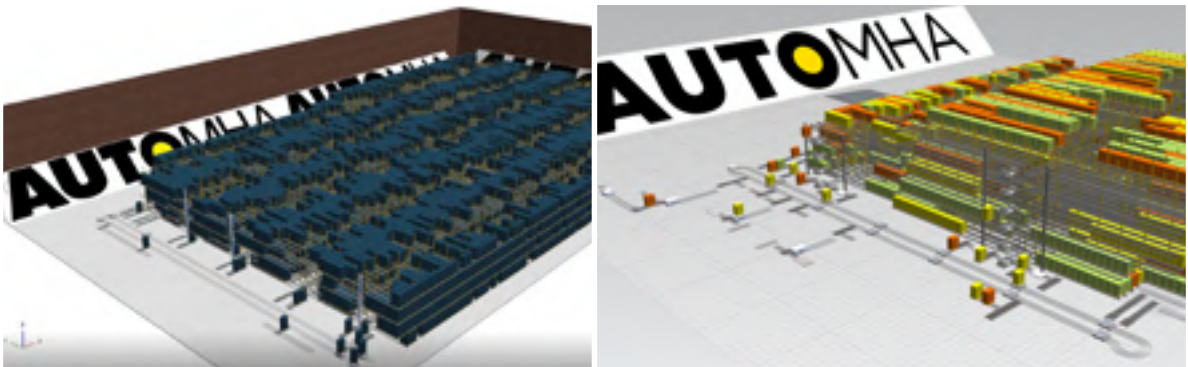

## 3.3 HMI



### USER-FRIENDLY INTERFACE

HMI, the acronym for **Human Machine Interface**, is Automha's captivating and user-friendly AWM interface.

**User profiling, dashboard personalization** and real-time management of alarms make information more usable and system access easier and more functional for warehouse operators, even those with less training.

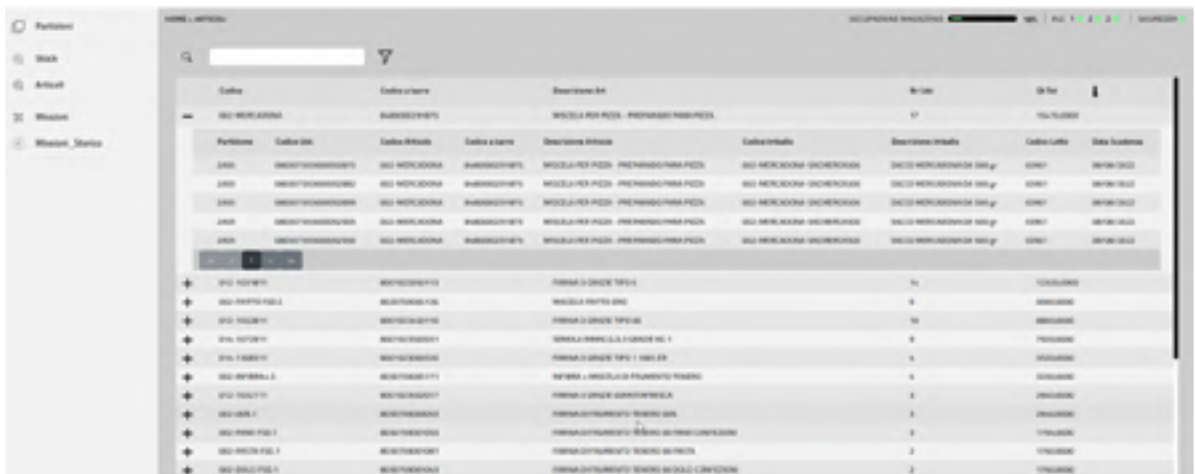

### 3.4 LOG



#### SEMI-AUTOMATIC WAREHOUSE MANAGEMENT SOFTWARE

LOG - Logistic Generation, is a recording software that makes a warehouse with Autosat technology as **traceable and independent** as a fully automated system.

LOG, using a simple, attractive interface, is a powerful and comprehensive tool for processing data concerning the handling of load units coming in and going out of the warehouse, whether in manual or semi-automatic mode.

**LOG processes all information** on the goods stored and **memorizes their features and movements** during the various management stages:

- **receipt:** LOG acquires data on the load unit and planning data on warehouse movements by the company ERP, process them and sends them back to the ERP once operations have been completed;
- **storage:** LOG controls the management and assignment of load unit locations according to company strategy (according to product, customer, production batch, etc.);
- **picking:** LOG controls the management of operations required to compile shipping or picking orders according to company strategy; this allows all goods in circulation in the warehouse to be mapped and their features, movements and location to be known.

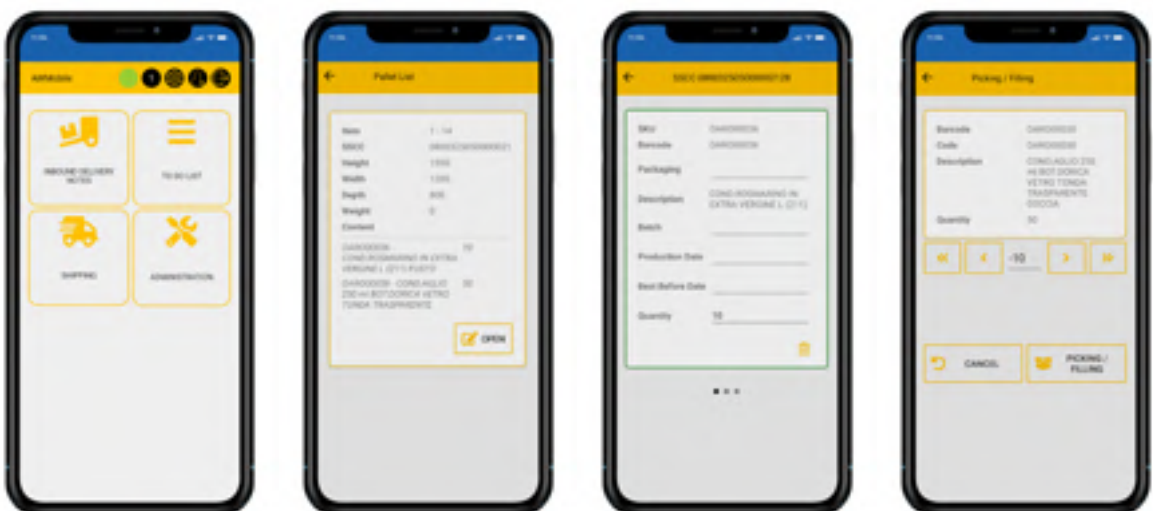

## HOW IT WORKS

The recording software is structured hierarchically and in modular form and allows the parameters and **positions of different elements to be stored and mapped:**

- **factory areas:** warehouses - database of physical or logical warehouses in the factory;
- **warehouse area:** each warehouse can be divided into various sub-areas;
- **channels:** each warehouse or area can be divided into various channels;
- **positions:** each channel or position is defined in terms of coordinates, dimensions and load capacity (even with multiple articles);
- **the details of operators, forklift trucks, customers and suppliers** can be registered and information (time and mission number, quantity of pallets per customer) recorded;
- **the details of the load units** are recorded using a coding system to which many customizable attributes may be associated. The attributes are those characteristics (colour, quantity, batch...) that are essential for future classification and analysis of warehouse movements.



### 3. SOFTWARE

#### The advantages of our solutions

- **Mapping:** allows you to always and immediately know where the goods are in the warehouse, know the movements made, the positions available and the cycles performed;
- **Reorganization:** the warehouse and warehouse areas can be reorganized and structured at any moment according to company procedures
- **Preparation:** LOG provides a sequence of the load lists to prepare, utilizing the available areas in the warehouse;
- **Traceability:** the operator can immediately track the goods stored in the warehouse lanes;
- **Reports:** LOG prepares accurate reports on the situation in the warehouse, on the cycles or on the activities performed by staff members, forklift trucks or customers;
- **License free:** the purchase of annual licenses or post-purchase licenses are not required with LOG;
- **Sizing:** LOG allows the customer to size the logical or physical warehouse at any moment using a two-dimensional array, customizing images, levels, channels and property.

#### DATA MANAGEMENT - ERP CUSTOMER

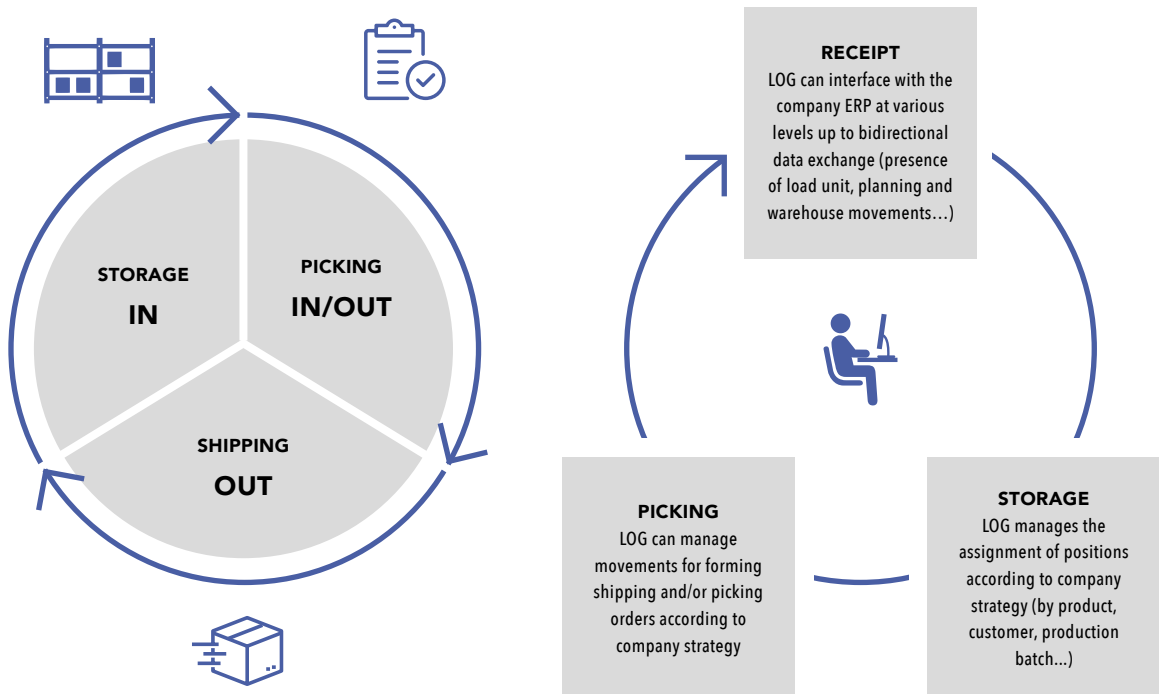







**CUSTOMER  
SERVICES**

## 4. CUSTOMER SERVICES

### REVAMPING AND UPGRADING TO SAFETY REQUIREMENTS

**Revamping** activities involve the modernization of old automated warehouses and their updating with the latest technology and safety regulations.

To ensure warehouse efficiency it is essential to periodically make **technological checks** of electrical and electronic parts.

For this reason, Automha designs solutions that are perfect for meeting customers' requests in the case of both transfer and extension of plants, offering a service of:

- **reconversion** of existing storage systems;
- **making systems more efficient** by installing hardware and software systems;
- **configuration** of new storage organization.

### AFTER-SALES ASSISTANCE

Automha provides much more than installation and start-up: by scheduling specific tutoring, maintenance and upgrade plans, managed directly from our maintenance office, the efficiency and safety of our systems are continuously monitored.

The aim of Automha is not only to **provide the best solutions for its customers**, but also to guarantee an excellent service, even in the after-sales stage. For this reason, Automha strives to draw up and supply to all its customers comprehensive instruction and maintenance manuals, which provide information on the correct and safe methods of using our system and machines. Each manual is drawn up in the **official language of the European Union** member country in which the system or machine is installed.

Automha has redefined the process of customer assistance and has **implemented Cloud software for managing assistance requests**. The customer assistance process has been revolutionized. Automha no longer uses emails to provide assistance and instead adopts one portal where all requests for assistance are collected so that service providers are offered a single-channel experience. The implementation and integration of this Cloud software in Automha is an example of how it is possible to work remotely and reach the goal in a short amount of time.

### VIRTUAL COMMISSIONING

Automha is one of the few companies in Italy and Europe to have developed a service of Virtual Commissioning, which involves **testing the automation code and warehouse management code** on a virtual reproduction of the warehouse (called Digital Twin) before commissioning the plant. Virtual Commissioning was a turning point: it reduces on-site commissioning times considerably, increases the safety of operators working on site, increases the level of innovation of Automha solutions and reduces software development times.

Virtual Commissioning **reproduces virtually the physical behaviour** of a plant or machine, as well as its control processes and systems using simulation technology, in order to innovate and make the company's specific work flow more efficient, minimizing risks and reducing costs and the time to commission a plant or machine.

The background features a solid dark blue color. Overlaid on this are several abstract geometric shapes in lighter shades of blue. These include a large, semi-transparent circle in the lower half, a smaller semi-transparent circle overlapping its top edge, and two overlapping semi-transparent rectangles in the upper half. The text 'AUTOMHA PRODUCTS' is centered in white, bold, uppercase letters, positioned over the overlapping circles.

**AUTOMHA  
PRODUCTS**

## 5. AUTOMHA PRODUCTS

# AUTOSAT



NEW GENERATION **SHUTTLE** DESIGNED  
FOR **AUTOMATED MULT-DEEP PALLET STORAGE**  
IN **DRIVE-IN SHELVING RACKS**



DISCOVER  
MORE

### The advantages of AUTOSAT

- Innovative high performance lithium-ion battery, removeable;
- No memory effect;
- Faster recharging and a high number of recharging cycles;
- Fast, safe storage;
- Lightweight structure and fast, silent handling;
- Cutting-edge safety devices;
- Efficient self-locking system in raised position with load on board;
- Versatility and adaptability with all drive-in structures, no modification to lift trucks needed;
- Suited to all industrial sectors and capable of operating up to -30C°;
- Innovative positioning with laser technology that avoids holes and cams on the guides;
- Vulkollan wheels for exceptional silence and greater acceleration;
- Better management of storage activities, the goods are always at the front of the warehouse thereby preventing damage to structures and goods;
- Optimization of spaces and internal costs;
- Latest generation LOG software for continuous monitoring of storage activities.



DISCOVER  
MORE

# SUPERCAP ES



**SATELLITE** DESIGNED TO WORK IN **MULTI-DEEP** STORAGE FACILITIES  
WITHIN AUTOMATED SYSTEMS; SUITABLE FOR USE  
WITH **ANY TYPE OF PALLET** AND LOAD UNIT

### The advantages of SUPERCAP

- Can be used in long storage rows due to an absence of electrical cables connecting the satellite to the parent vehicle;
- Extreme flexibility: it can be used on different types of parent vehicles;
- Possible multiple management of satellites by the parent vehicle;
- The Supercap automated system can be accessed from an external station to evaluate and modify its parameters;
- Total reliability and safety;
- Minimum recharging times;
- No maintenance required;
- Long vehicle life.

# AUTOSATMOVER



DISCOVER  
MORE

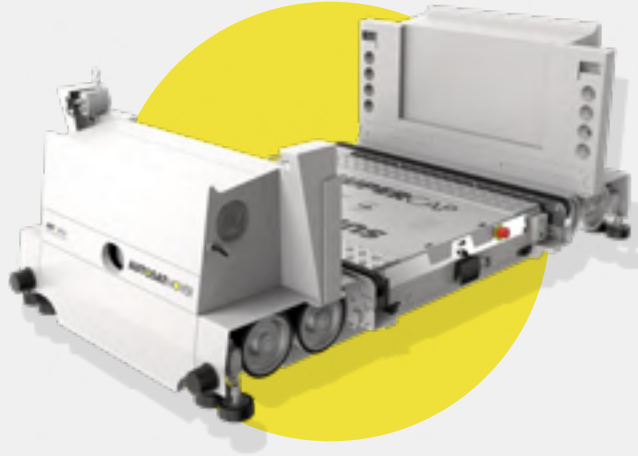

NEW GENERATION **MODULAR SYSTEM**,  
FULLY AUTOMATIC FOR THE AUTOMATION  
OF **MULTI-DEEP STORAGE OF PALLETS**

## The advantages of AUTOSATMOVER

- Easier access to the complete plant;
- Consumption and costs halved compared to normal automated storage systems;
- Increase in overall performance of the plant;
- Simple and fast installation;
- Predictive maintenance;
- Access to the plant during assistance and maintenance activities;
- Total flexibility and ease of picking;
- Performance unchanged at temperatures from -30°C to +45°C;
- Designed by Automha.



DISCOVER  
MORE

# RUSHMOVER



FULLY AUTOMATED **MODULAR CIRCUIT**  
WITH ABILITY TO **CURVE IN TWO DIRECTIONS**  
FOR ANY TYPE OF **TRANSPORT** AND LOAD UNIT

### The advantages of RUSHMOVER

- Modular system;
- Possibility of direction changes;
- Management of long and complex circuits;
- Lightweight rails that are easy to install;
- Easy maintenance;
- Remote control for manual commands to manage several shuttles;
- Roller or chain conveyor can be installed on the machine depending on requirements;
- Suitable for all types of pallet;
- Suitable for all industrial sectors;
- Performance remains unchanged at temperatures ranging from -30°C to +45°C;
- Designed by Automha.



# PEAKMOVER



DISCOVER  
MORE

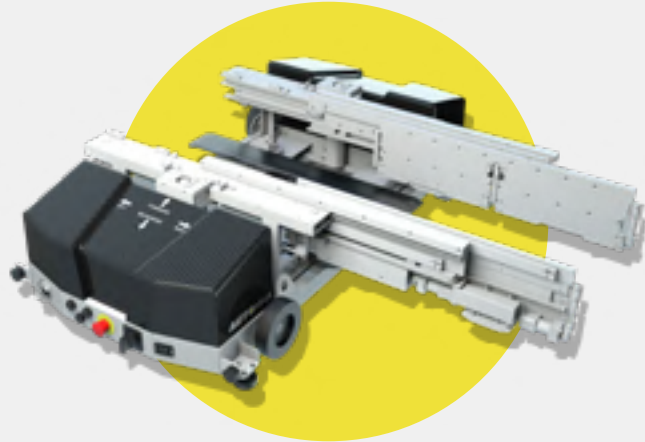

SYSTEM FOR HANDLING AND **AUTOMATED STORAGE**  
OF **CARDBOARD AND PLASTIC BOXES.**  
IDEAL FOR **E-COMMERCE**/DISTRIBUTION CENTRES

## The advantages of PEAKMOVER

- Compact size;
- Fork extensions with better performance than those of other similar machines;
- Suitable for the double-deep storage of boxes with lengths of up to 600 mm;
- Greater storage density on the shelving racks;
- Versatility: fork spacing can be changed so that the machines are able transport packages of different sizes;
- Pickup equipment powered and controlled using wireless solutions;
- Greater sturdiness;
- Low maintenance costs;
- Rapid recharging thanks to supercapacitor technology.



DISCOVER  
MORE

# HEAVYTOWER



AUTOMATED **VERTICAL STORAGE** SYSTEM  
DESIGNED TO STORE **LONG ITEMS**,  
SHEET METAL AND **HEAVY ARTICLES**

### The advantages of HEAVYTOWER

- "Goods to person" principle;
- Efficient use of space;
- High capacity in minimum area;
- Easy material handling;
- Excellent material protection;
- Internal and external installation;
- Easy system control and maintenance;
- Equipped with all safety devices for users.

# MINILOAD

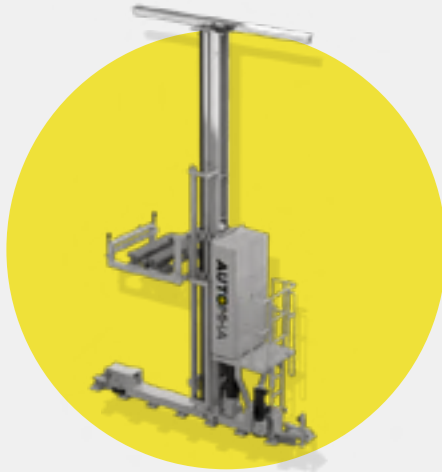

**AUTOMATED STORAGE SYSTEMS**  
FOR **CONTAINERS OR TRAYS**, USED FOR WAREHOUSES  
WITH HIGH PICKING FLOWS OF **HEAVY GOODS**



DISCOVER  
MORE

## The advantages of MINILOAD

- Cost savings: BOOSTER machines deliver energy savings, and during the stages of cart traverse deceleration and descent, the motors generate power, which is returned to the factory's electrical power grid, resulting in substantial cost savings;
- Silent operation;
- Stripped-down design: the machine consists of fundamental parts that are easy to identify and maintain;
- Unit weight transported of up to 300 kg: with unchanged cycles compared to classic miniloads (for small warehouses);
- Management of different Load Units; trays, cardboard boxes, plastic boxes of different measurements and heights; load unit personalization on request;
- Suitable for all sectors;
- Can be installed at low temperatures.

## 5. AUTOMHA PRODUCTS



DISCOVER  
MORE

# SRM

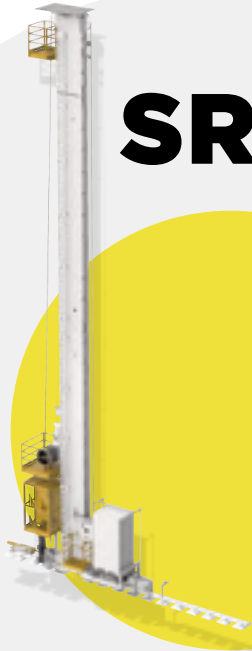

**WAREHOUSES** FOR THE AUTOMATED STORAGE  
OF LOAD UNITS OF **ANY SIZE AND WEIGHT**  
IN **INDUSTRIAL BUILDING** AND FREE-STANDING STRUCTURES

### The advantages of SRM

- Cost saving: SRM Stacker Crane machines deliver energy savings, and during the stages of cart traverse deceleration and descent, the motors generate power, which is returned to the factory's electrical power grid, resulting in substantial cost savings;
- Silent operation;
- Management of different Load Units: pallets of any size, metal or plastic containers, trays, frames, rolls and reels, long items, motor vehicles, finished products;
- Can be adapted to existing structures
- Possibility of multi-deep storage using on-board satellites
- Suitable for all industrial sectors, particularly the textile sector;
- Can be installed at temperatures from -30°C to +45°C.

# UNIFLEX



RANGE OF **FLEXIBLE CONVEYORS**  
WITH SWIVEL **WHEELS**, EXTENSIBLE AND DURABLE  
FOR BULK **LOADING AND UNLOADING** APPLICATIONS



DISCOVER  
MORE

## The advantages of UNIFLEX

- UniFlex increases the efficiency of material handling by up to 50% during bulk unloading/loading of trucks, delivering a quick return on invested capital;
- It satisfies all legal requirements regarding manual handling;
- AC SEW EuroDrive Motors- the speed of the conveyor is adjustable from 10 to 40 metres per minute; 0.09 kW for 230 V/240 V single-phase power supply;
- Motor saver: all motors are equipped with overload protection and trip signalling LEDs;
- Electrical controls are housed in solid steel cabinets, sealed according to the IP55 standard;
- The conveyor complies with all relevant EC laws;
- Easy to move and reposition for multiport applications (unlike conveyors with telescopic arm);
- Sides made of galvanized sheet steel, reinforced with ribs to ensure maximum strength and durability,
- Integral bolts: there are no rivets;
- Large steel handles, coated in yellow, for a secure grip and ease of conveyor handling;
- All support legs are equipped with welded reinforcements for great strength and rigidity.

## 5. AUTOMHA PRODUCTS



DISCOVER  
MORE

# PALLETRUNNER

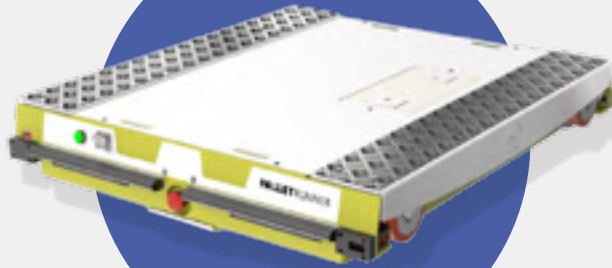

NEW GENERATION **SHUTTLE**  
DESIGNED FOR **AUTOMATED MULTI-DEEP PALLET STORAGE**  
IN DRIVE-IN SHELVING RACKS

Automha owns the Autosat and Pallet Runner brands.  
Autosat is marketed under the name Pallet Runner in the North American market.

### The advantages of PALLETRUNNER

- Innovative high performance lithium-ion battery, removeable;
- No memory effect;
- Faster recharging and a high number of recharging cycles;
- Fast, safe storage;
- Lightweight structure and fast, silent handling;
- Cutting-edge safety devices;
- Efficient self-locking system in raised position with load on board;
- Versatility and adaptability to all drive-in structures, no modification to lift trucks needed;
- Suited to all industrial sectors and capable of operating up to -30C°;
- Innovative laser technology positioning that avoids the use of holes and cams on the guides;
- Vulkollan wheels for exceptional silence and greater acceleration;
- Better management of storage activities, the goods are always at the front of the warehouse thereby preventing damage to structures and goods;
- Optimization of spaces and internal costs;
- Latest generation LOG software for continuous monitoring of storage activities.

**A  
U  
T  
O  
M  
H  
A**





# WORLDWIDE REFERENCES



## 6. WORLDWIDE REFERENCES

**Asahi**



**Coca-Cola**



**AVIKO**



**CAPRAL**



**AGIE CHARMILLES**



**AkzoNobel**



**CAVIRO**



## 6. WORLDWIDE REFERENCES





Unilever



PRADA



Fiducia ben nutrita.



CRODA



Vardhman



let's open our eyes



ITALIAN PACKAGING SOLUTIONS



energia positiva



COLD LOGISTICS BY NEWCOLO



## 6. WORLDWIDE REFERENCES



PEE VEE TEXTILES  
FINEST SKIITS, FINEST TRASTIETS



SHAHI

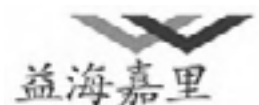

...and many more.

# AUTOMHA

[automha.com](https://automha.com)



2022 © AUTOMHA S.P.A. | 01-2022 | 00

All rights reserved. All text, images, photographs and tables are subject to copyright and intellectual property laws.

The contents may only be used with the express authorization of Automha S.p.A. All contents included may be subject to revision and changes given the continuous development of our products in line with technological progress. Changes in content will not be communicated proactively. Technical specifications may vary from country to country.