

PHIEQUIPE

ITALIAN MOTORBOATS



**BRAND
PHIEQUIPE**

ITALIAN MOTORBOATS

PHIEQUIPE



PHIEQUIPE Italian Motorboats is a line of compact and agile boats intended as “high-end” yacht tenders or comfortable and elegant day cruisers.

Phiequipe Italian Motorboats’s design is based on the concept of the “luxury tender”, a meticulous attention to the details, refined materials such as teak, leather and stainless steel. An accurate study of the ergonomics, stability and maneuverability confers to our whole range of boats an elegant and sophisticated look as well as enhanced performance and comfort while sailing.

Phiequipe Italian Motorboats offers two main layouts, a center console version for a more classic approach to sailing and a “motorcycle-like” saddle for different and fun steering sensations. The materials and colours are customizable to fit the standards and requirements of our customers.

DESIGN
PHIEQUIPE

ITALIAN MOTORBOATS

PHIEQUIPE

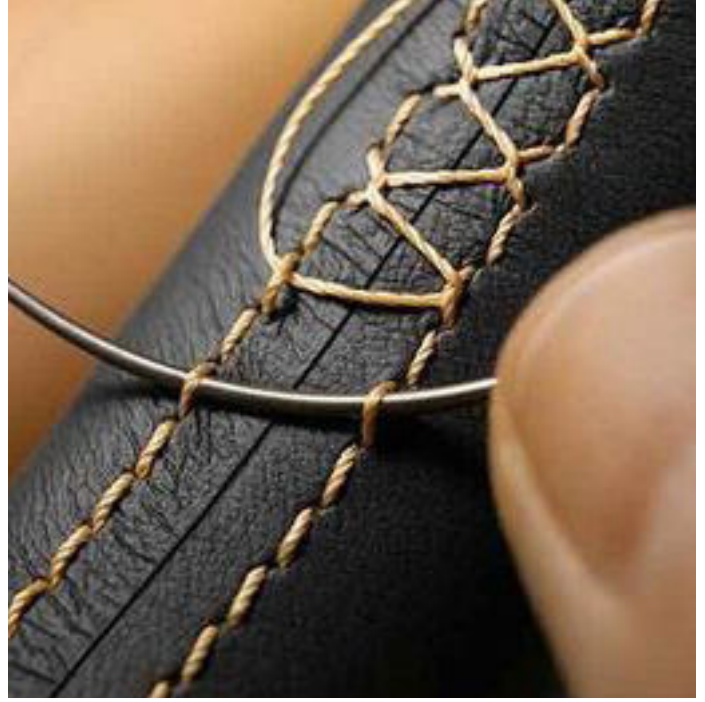

We were inspired by a lot of different areas such as classic motorcycles, classic cars, fashion design and modern art. All of these were combined to make an elegant and timeless design for our boat line.

The interior design is essential yet rich and comfortable, well balanced to permit the user to feel closer to the sea. The materials are customizable to allow the owner to feel a part of the design process.

MB 11

PHIEQUIPE

ITALIAN MOTORBOATS

PHIEQUIPE



MB 11

PHIEQUIPE



MB 11

PHIEQUIPE



MB 11

PHIEQUIPE

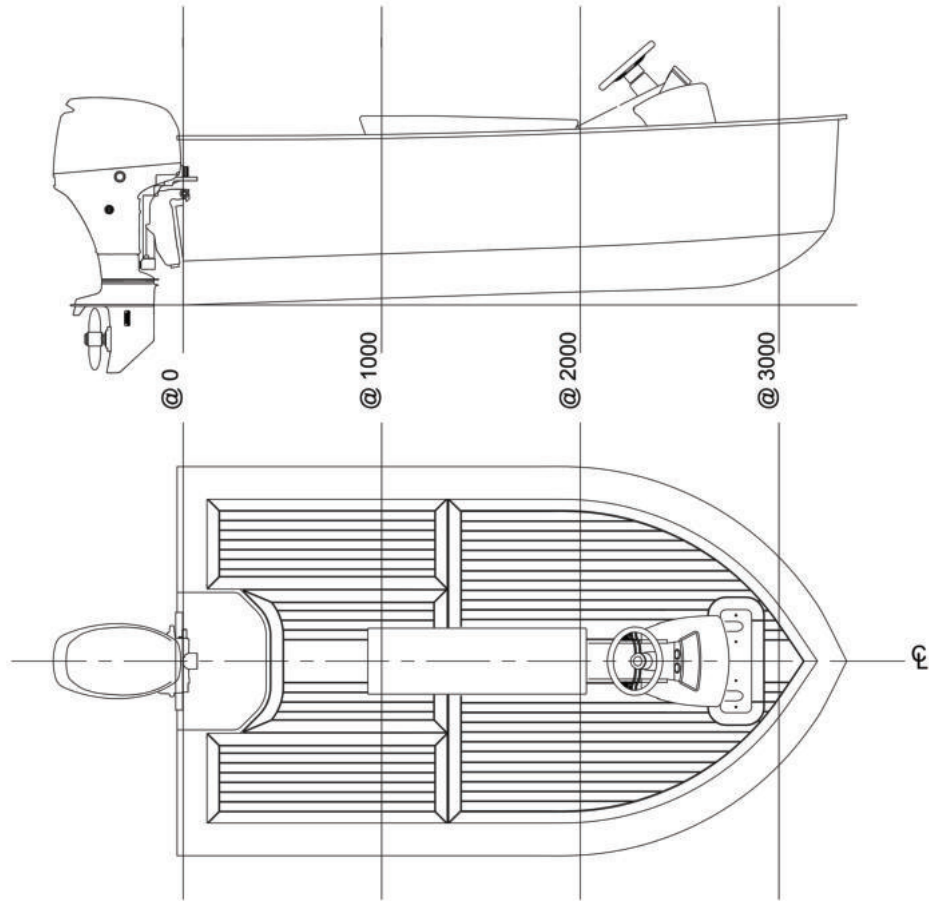

- L_{hull} 3,35 m
- LOA 3,50 m
- BOA 1,95 m
- Engine Maximum 40 HP outboard engine
- Crew 4 people
- Design cat C
- Dry weight 320 kg c.a. (with 40 HP outboard engine)

MB 12

PHIEQUIPE

ITALIAN MOTORBOATS

PHIEQUIPE



MB 12

PHIEQUIPE



MB 12

PHIEQUIPE

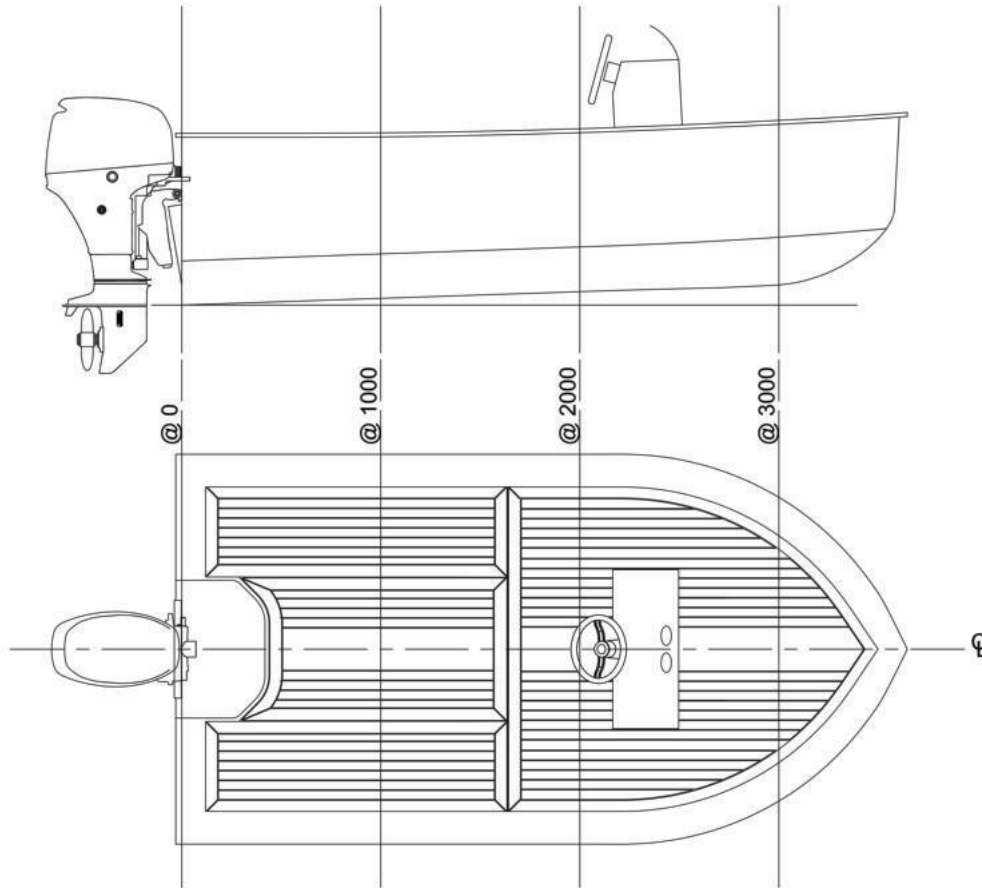

- L_{hull} 3,68 m
- LOA 3,90 m
- BOA 1,96 m
- Engine Maximum 40 HP outboard engine
- Crew 5 people
- Design cat C
- Dry weight 350 kg c.a. (with 40 HP outboard engine)

MB 18

PHIEQUIPE

ITALIAN MOTORBOATS

PHIEQUIPE



MB 18

PHIEQUIPE



MB 18

PHIEQUIPE



MB 18

PHIEQUIPE



MB 18

PHIEQUIPE

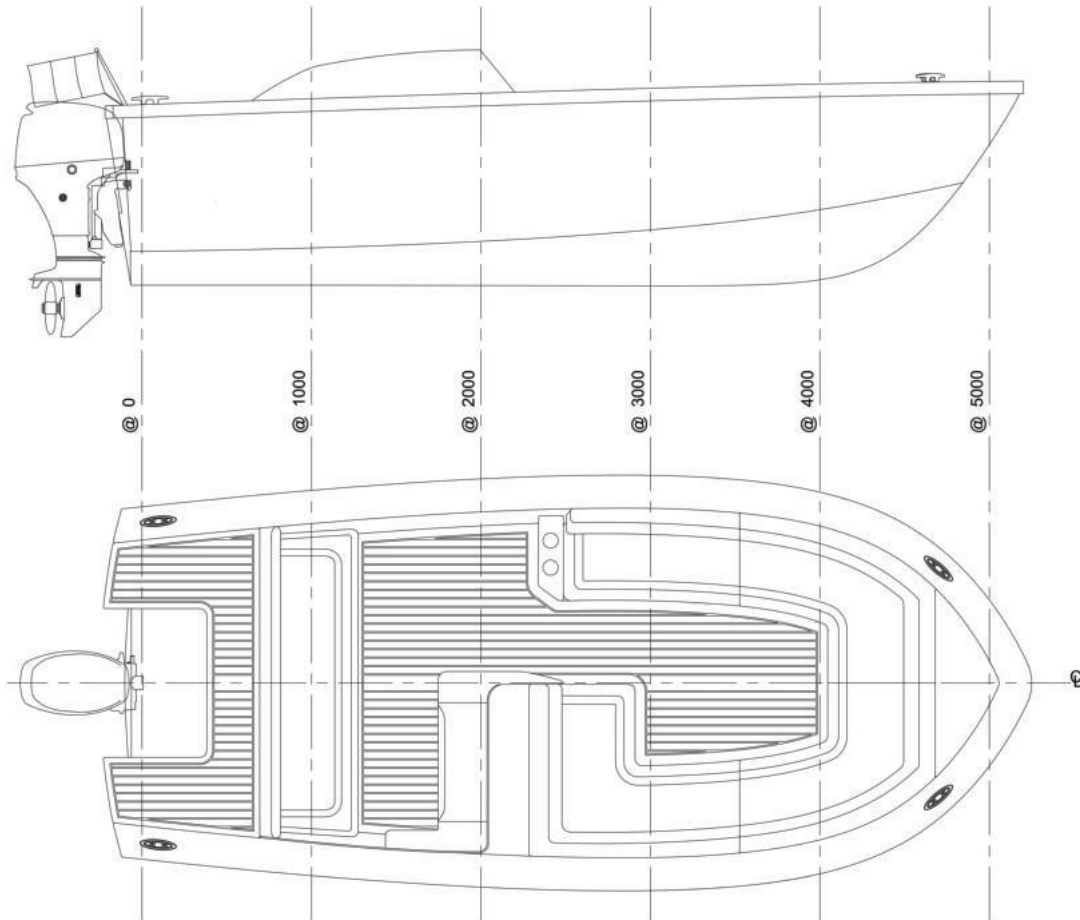

- L_{hull} 5,40 m
- LOA 5,80 m
- BOA 2,45 m
- Engine Maximum 115 HP outboard engine
- Crew 5 people
- Design cat C
- Dry weight 960,0 kg c.a. (with 70 HP outboard engine)

MB 18

TENDER

PHIEQUIPE

ITALIAN MOTORBOATS

PHIEQUIPE



MB 18 Tender

PHIEQUIPE



MB 18 Tender

PHIEQUIPE



MB 18 Tender

PHIEQUIPE



MB 18 Tender

PHIEQUIPE

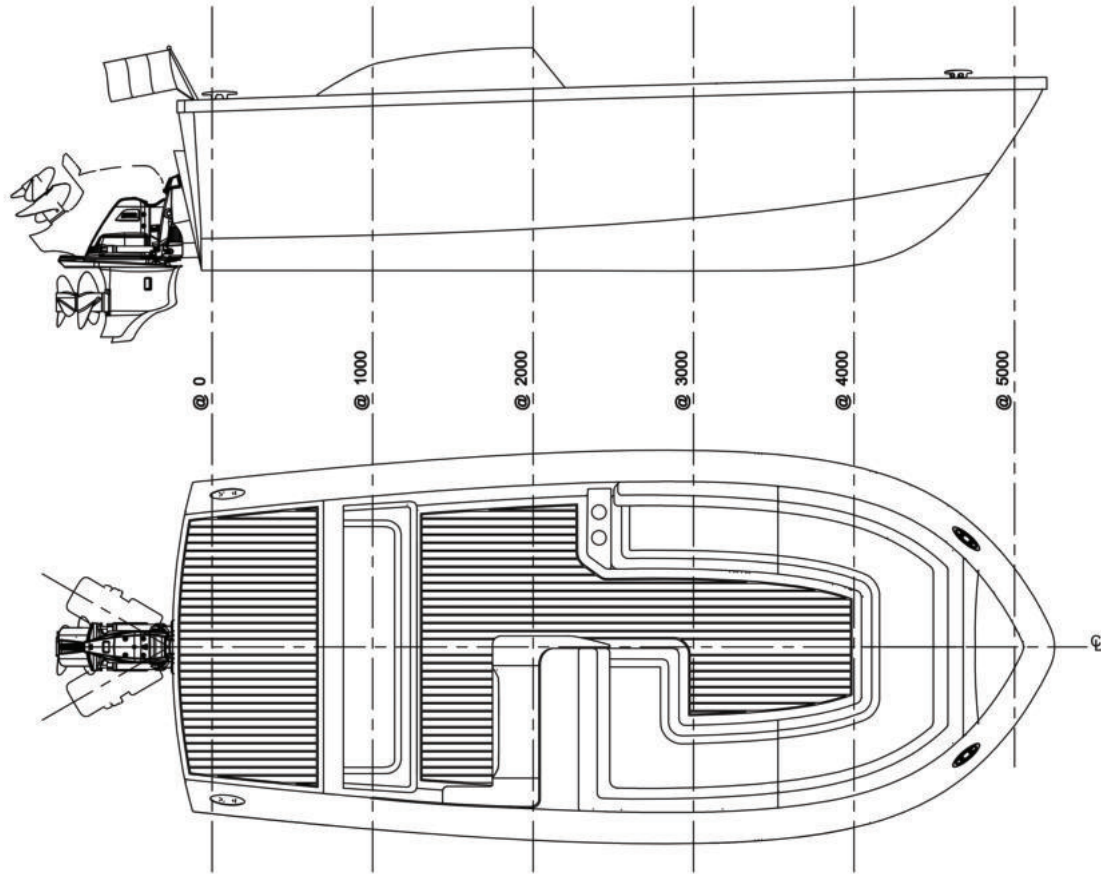

- L_{hull} 5,40 m
- LOA 5,80 m
- BOA 2,45 m
- Engine Maximum 200 HP inboard engine (gasoline)
Maximum 150 HP inboard engine (diesel)
- Crew 6 people
- Design cat C
- Dry weight 1280,0 kg c.a.

MB 21
LEVRIERO
PHIEQUIPE
ITALIAN MOTORBOATS

PHIEQUIPE



MB 21 Levriero

PHIEQUIPE



MB 21 Leviero

PHIEQUIPE

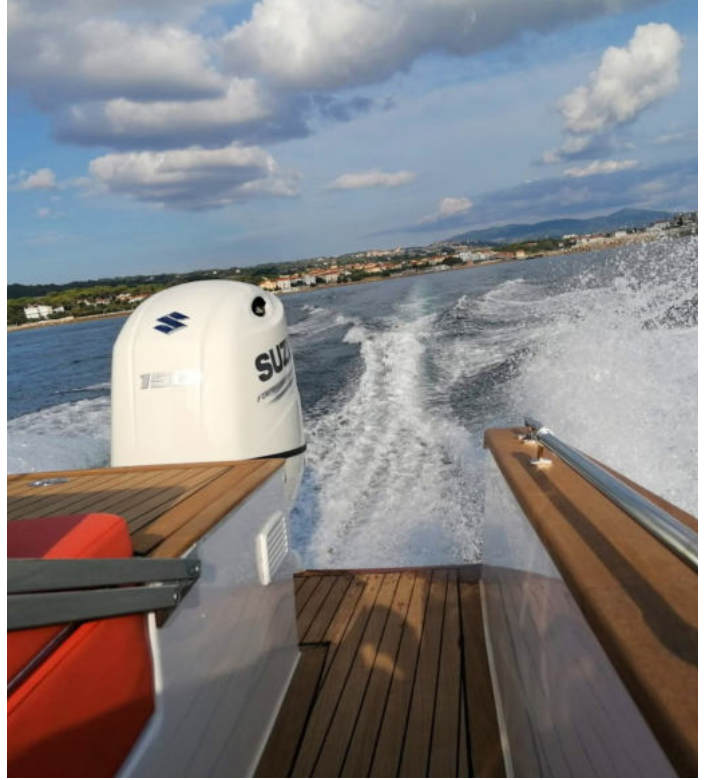

PHIEQUIPE

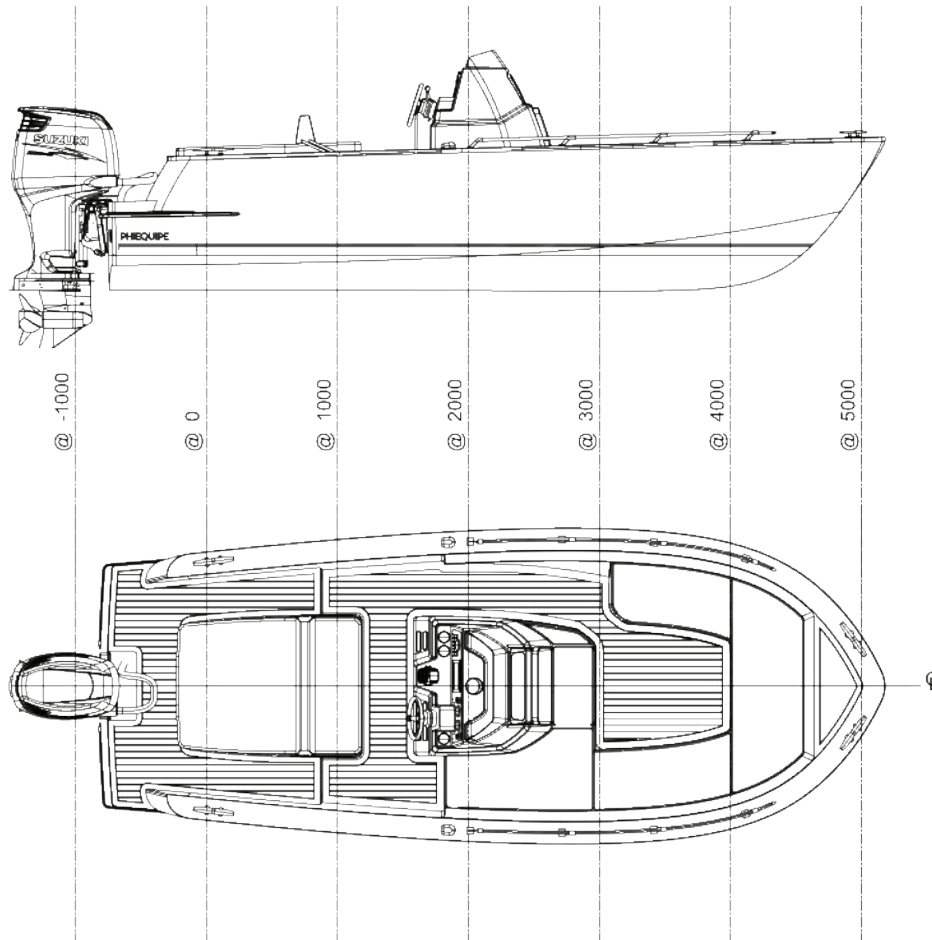

- L_{hull} 5,99 m
- LOA 6,20 m
- BOA 2,45 m
- Engine 150 HP outboard engine
- Crew 6 / 7 people
- Design cat C / D
- Dry weight 1250,0 kg c.a.



PHIEQUIPE
ITALIAN MOTORBOATS

Viale Italia, 115 - 57127 Livorno (LI)
Phone / Fax: +39 0586 211926
www.phiequipe.it - contact@phiequipe.it