



TOTEM  
OF DESIGN

# LUXURY DESIGN FOR MULTIMEDIA

MONNALISA



# Art for multimedia

Monnalisa is the connection between the traditional luxury style of Florence and the evolution of communication towards digital signage.

The product is still in the center of the communication and is well exposed to customers but is supported aside by the digital content in a strength communicative structure to achieve the maximum desire effects.





## Finest materials to best represent your products

Shelves are configurable in different positions and height to fit the best requirements to expose the real products. Metal can be plated or covered with different finishes or materials as wood, leather or marble for a stunning shining effect.

Display can be connected to a digital player or to a network and be controlled remotely. Touch screen can be implemented to provide interactive functions to the system.

# Monnalisa Dimension

## PHYSICAL SPECIFICATION

Width	93 cm
Depth	41 cm
Height	205 cm
Weight net	70 kg

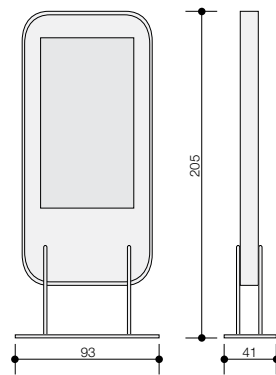

Patent desing

Width	148 cm
Depth	50 cm
Height	205 cm
Weight net	80 kg

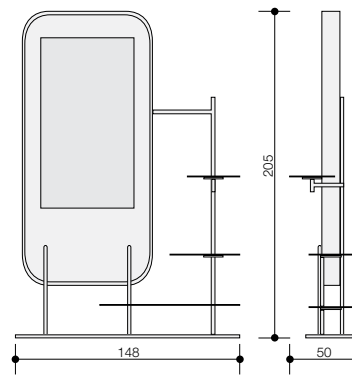

Width	150 cm
Depth	50 cm
Height	195 cm
Weight net	100 kg

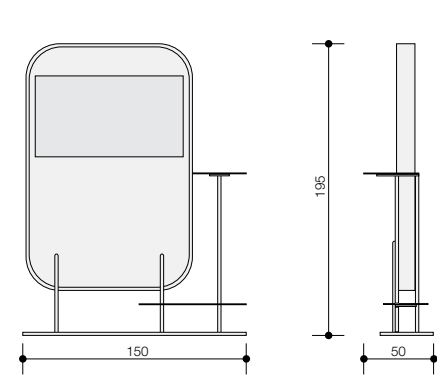

## Finishes

### METAL



### REAL WOOD



### MARBLE



Other finishes available on request

TOTEMOFDESIGN.IT