



# Steel Pipes Fittings Flanges Forgings & Spools

quality and service for business



**FORITEX** has been serving the Oil, Gas and Power Industries (conventional and nuclear) for 35 years. Our own production of non-standard piping components and piping fabrication/assembly, coupled with our extensive and close network with manufacturers and stockists enable **FORITEX** to offer a comprehensive supply capability.

**FORITEX** supply range is available in the following pages. All piping components are manufactured in accordance with International Standards, Customers' drawings, and/or designed to comply with project's requirements and data sheets.

**FORITEX** can support clients by supplying design, calculation and stress analysis (FEA) of WYE, branch and piggable fittings, pipeline flanges, bolts & nuts, gaskets and nozzles.

**FORITEX** can also supply full inspection services carried out by qualified independent inspectors.

**FORITEX** is your ideal partner for your piping purchasing requirements. Our technical and commercial expertise, earned through years in the business, ensures all materials supplied meet client's technical requirements and, equally important, within the contractual delivery time. The enclosed reference list is evidence of our clients' satisfaction with our performance over the years.

We look forward to be given the opportunity to prove our capabilities to you.

Managing Director

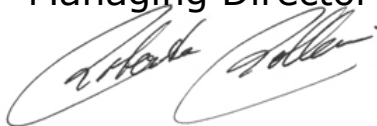
A handwritten signature in black ink, appearing to read 'Ahmed Salim', is written over a faint background image of an industrial facility.

**FORITEX** offer professional engineering support to cover specific project requirements.

Our engineering team can assist clients in all aspects of design, calculation and verification thanks to the experience acquired through the years in the oil, gas, power plant (conventional and nuclear) and pressure vessel industries.

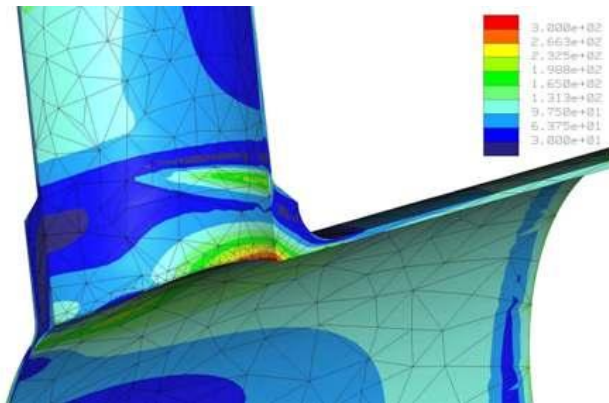

**FORITEX** design process is supported with the use of Computer Aided Design (CAD) and the latest 3D solid modeling software with Finite Elements Analysis (FEA).

If required, design can be verified by a third party engineer.

**FORITEX** can design the following products:

- ✓ Wye & Piggable Wye
- ✓ Swivel, Anchor, Hanger, Misalignment & Hot Tap Flange
- ✓ Barred, Flow, Studded & Lateral Tee
- ✓ Buckle Arrestor & J-Lay Collar
- ✓ Pig Launcher / Receiver & Piping Spool
- ✓ Self-reinforced branch fitting (outlet fitting): sweep, vessel, lateral, weld or flanged outlet

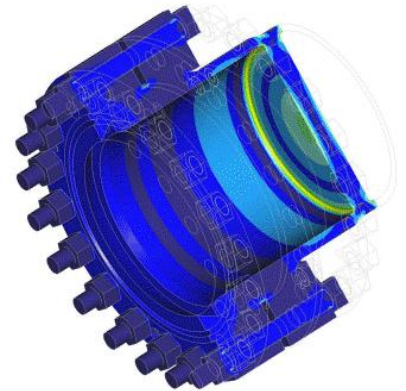

Design in accordance to the following standards and norms:

- ✓ ASME B31.1, B31.3, B31.4 and B31.8
- ✓ Pressure Equipment Directive 97/23/EC (PED)
- ✓ ASME Boiler and Pressure Vessel Code (BPVC) Section I
- ✓ ASME Boiler and Pressure Vessel Code (BPVC) Section III
- ✓ ASME Boiler and Pressure Vessel Code (BPVC) Section VIII div. 1 & 2
- ✓ RCC-M
- ✓ Others

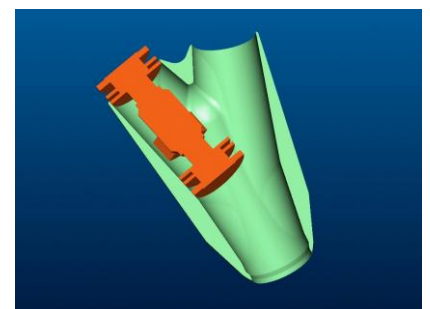
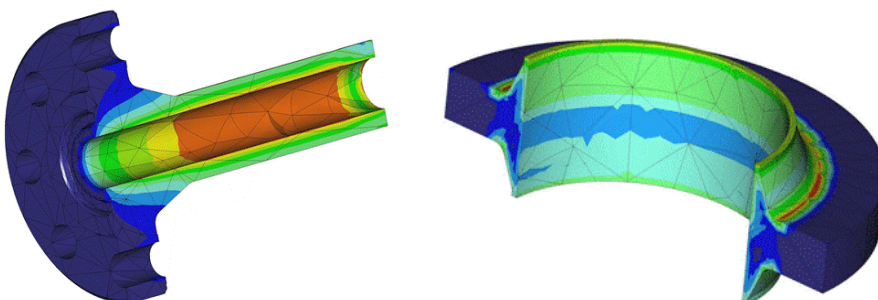
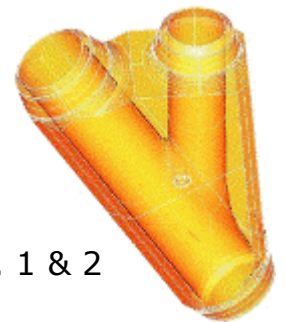

**FORITEX** manufactures and supplies non-standard piping components and piping fabrication/assembly to major International Fabricators, Engineering, Contractors, Power (conventional & nuclear) and Oil-Gas companies and believes that quality and service are key to its success and over the years has earned the trust of its customers.

Its motto: **Quality and Service for business** is therefore aimed at assuring its customers complete satisfaction via:

**Quality**: products and services must always fulfil at first delivery to the agreed contractual terms and to all other applicable requirements concerning customer satisfaction.

**Service**: customers are able to obtain assistance and information in a fast and efficient manner, and can count on reliable and predictable time of delivery.

## **Management Commitments & Corporate Value**

- ✓ Ensure Staff are **safe, healthy** and operate within a **stimulating** working environment;
- ✓ Provide to Suppliers a **common seamless route** in enhancing quality products and services;
- ✓ Ensure to Company **business development** through higher productivity, investigation of new markets and continuous improvement of its management system;

**FORITEX** is certified **ISO 9001:2015** and holds approvals and qualifications from major firms.





# Certificate

SQS herewith certifies that the company named below has a management system which meets the requirements of the standard specified below.



**Foritex S.r.l.**  
**Via Emilia Piacentina, 12**  
**29010 Sarmato (PC)**  
**Italy**

Scope of certification

**Site of Via Emilia Piacentina, 12**  
**29010 Sarmato (PC)**  
**Italy**

Field of activity

**Design and Manufacture of fittings, flanges and piping components for the oil & gas, power and related industries. Supply of items in accordance to PED material requirements**

Normative base

**ISO 9001:2015**

**Quality Management System**

Scope(s) 17

Validity 31.07.2016–30.07.2019  
Issue 31.07.2016

Reg. no. 34035

X. Edelmann, President SQS

R. Glauser, CEO SQS



sqs.ch



Swiss Association for Quality and Management Systems SQS  
Bernstrasse 103, 3052 Zollikofen, Switzerland



Swiss Made





THE INTERNATIONAL CERTIFICATION NETWORK

# CERTIFICATE

*SQS and IQNet Partner hereby states that the organization*

***Foritex S.r.l.***  
***Via Emilia Piacentina, 12***  
***29010 Sarmato (PC)***  
***Italy***

*for the following scope and type of activities*

***Site of Via Emilia Piacentina, 12***  
***29010 Sarmato (PC)***  
***Italy***

***Design and Manufacture of fittings, flanges and piping components  
for the oil & gas, power and related industries. Supply of items in accordance to  
PED material requirements***

*has implemented and maintains a*

***Management System***

*which fulfills the requirements of the following standard(s)*

***ISO 9001:2015 / Quality Management System***

*for the validity date, please refer to the original certificate\* issued by SQS*

*Scope No(s): 17*

*Issued on: 2016-07-31*

*Validity date: 2019-07-30*

*Registration Number: CH-34035*



*Michael Drechsel*  
*President of IQNet*

*Roland Glauser*  
*CEO SQS*



**IQNet Partners\*\*:**

AENOR Spain AFNOR Certification France AIB-Vinçotte International Belgium APCER Portugal CCC Cyprus  
CISQ Italy CQC China CQM China CQS Czech Republic Cro Cert Croatia DQS Holding GmbH Germany  
FCAV Brazil FONDONORMA Venezuela ICONTEC Colombia IMNC Mexico Inspecta Certification Finland INTECO Costa Rica  
IRAM Argentina JQA Japan KFQ Korea MIRTEC Greece MSZT Hungary Nemko AS Norway NSAI Ireland PCBC Poland  
Quality Austria Austria RR Russia SIGE México SII Israel SIQ Slovenia SIRIM QAS International Malaysia  
SQS Switzerland SRAC Romania TEST St Petersburg Russia TSE Turkey YUQS Serbia  
IQNet is represented in the USA by: AFNOR Certification, CISQ, DQS Holding GmbH and NSAI Inc.

\* This attestation is directly linked to the IQNet Partner's original certificate and shall not be used as a stand-alone document

\*\* The list of IQNet partners is valid at the time of issue of this certificate. Updated information is available under [www.iqnet-certification.com](http://www.iqnet-certification.com)

**FORITEX S.r.l.**  
Via Emilia Piacentina, 12  
29010 SARMATO (PC) - ITALY  
tel +39 0523 886164  
e-mail [foritex@foritex.it](mailto:foritex@foritex.it)  
attn Mr. Roberto Bollani

**Machine Shop**  
24040 Levate (BG)  
ITALY

**CONSULTANT FOR THE FAR EAST**  
**FOREAST PTE LTD**  
tel +65 6547 8305  
e-mail [foreast@singnet.com.sg](mailto:foreast@singnet.com.sg)  
attn Mr. Tan Kim Hock

**Sales Offices**

**SINGAPORE**  
**M3 MARKETING & ENGINEERING SERVICES**  
tel +65 68 722208  
e-mail [m3mktg@singnet.com.sg](mailto:m3mktg@singnet.com.sg)  
attn Mr. Ivan Chua

**GREECE**  
**INDUSTRIAL STEEL**  
tel +30 210 2856559  
e-mail [vassilis.boukouvalas@industrialsteel.gr](mailto:vassilis.boukouvalas@industrialsteel.gr)  
attn Mr. Vassilis Boukouvalas

**INDONESIA**  
**PT. DWIRESTU REJEKIGUNA**  
tel +62 21 6267576  
e-mail [sales@dwirestu.com](mailto:sales@dwirestu.com)  
attn Mr. Yohan Sutandar

**CANADA**  
**MAYAR TAHA**  
tel +1 416 578 7525  
e-mail [mahyartaha@hotmail.com](mailto:mahyartaha@hotmail.com)  
attn Mr. Mayar Taha

**PAKISTAN**  
**PIPES & FITTINGS SUPPLIER CO.**  
tel +92 42 35311946 / mob +92301 8436459  
e-mail [pipesfittingsupplier@gmail.com](mailto:pipesfittingsupplier@gmail.com)  
attn Mr. Mohammad Sheraz

**GREAT BRITAIN**  
**CUBOSTEEL INTERNATIONAL LTD**  
tel +44 1292 265275  
e-mail [cubosteel@aol.com](mailto:cubosteel@aol.com)  
attn Mr. David Cunningham

**SOUTH KOREA**  
**SEJIN CORPORATION**  
tel +82.52.265.1278  
e-mail [sejintl@sejintl.com](mailto:sejintl@sejintl.com)  
attn Mr. Son Hong Dae

**AUSTRALIA**  
**GLOBAL STEEL SOURCING**  
tel +61 (0) 499.996.515  
e-mail [michaelwhitaker@globalsteels.com.au](mailto:michaelwhitaker@globalsteels.com.au)  
attn Mr. Michael Whitaker

**IRAN**  
**MIDDLE EAST INDUSTRIAL PROFESSION (MIP Co LLC.)**  
tel :+98 9124345067  
e-mail [info@fidarindustrial.com](mailto:info@fidarindustrial.com)  
attn Mr. Amir Mirzaeifard

**INDIA**  
**APPLIED TEK AND MANAGEMENT CONSULTANCY PVT.LTD.**  
tel +91 22 66920074 / 75  
e-mail [suresh@appliedtek.org](mailto:suresh@appliedtek.org)  
attn Mr. Suresh G. Mirchandani

**KINGDOM of SAUDI ARABIA**  
**ART LAND INDUSTRIAL MARKETING CO.**  
tel +966 532 559 911  
e-mail [hilal@aim-ksa.com](mailto:hilal@aim-ksa.com)  
attn Mr. Mohammed Hilal

**PRODUCTS LIST**

- ✓ Welded & Seamless pipes
- ✓ Hollow forged pipes
- ✓ Deep-bored pipes
- ✓ Pipe spools
- ✓ Manifolds
- ✓ Forgings
- ✓ Flanges
- ✓ Lap Joint Stubends
- ✓ Vessel flanges
- ✓ Contoured nozzles
- ✓ Long WN
- ✓ Tubesheets
- ✓ Swivel, Anchor, Hanger, Misalignment & Hot Tap flanges
- ✓ AWWA flanges
- ✓ Packing & Gaskets
- ✓ Buttweld fittings
- ✓ Pipe bends
- ✓ Piggable fittings
- ✓ Sphere & Flow tees
- ✓ Barred & Target tees
- ✓ Piggable WYE & Lateral tees
- ✓ Buckle Arrestor & J-Lay Collar
- ✓ Power plant fittings
- ✓ Screwed & Socket-weld fittings
- ✓ Branch outlet fittings
- ✓ Ring-joint gaskets
- ✓ Bolts & Nuts
- ✓ Special fasteners & Stud-bolts
- ✓ Patented Quick Opening Closures and Pig Launchers & Receivers
- ✓ Weld-overlaying of flanges, nozzles & fittings

**STANDARDS**

- |         |        |        |         |         |
|---------|--------|--------|---------|---------|
| ✓ AFNOR | ✓ ASTN | ✓ CSA  | ✓ GHOST | ✓ NACE  |
| ✓ ANSI  | ✓ ASTM | ✓ DIN  | ✓ ISO   | ✓ RCC-M |
| ✓ API   | ✓ AWS  | ✓ EMUA | ✓ MSS   | ✓ JIS   |
| ✓ ASME  | ✓ BSI  | ✓ EN   |         |         |

**MATERIALS**

- ✓ Carbon & Low Temp. Steel
- ✓ High Yield Steel
- ✓ Stainless Steel
- ✓ Duplex & Super Duplex Steel
- ✓ Low & High Alloy Steel
- ✓ Titanium
- ✓ Exotic steels



**CERTIFICATION**

- ✓ Standard: EN 10204 Type 3.1
- ✓ Upon request: EN 10204 Type 3.2 countersigned by Lloyd's Register, TUEV, Det Norske Veritas, Bureau Veritas or other independent authority.

**INDUSTRIES**

- ✓ Oil and Gas (onshore and offshore)
- ✓ Petrochemical and Chemical Plants
- ✓ Power Plants (conventional & nuclear)
- ✓ General Industry



<i>Machining units available for machining operation</i>	<i>builder</i>	<i>model</i>	<i>year of construction / revision</i>	<i>dimensional capacity values in mm</i>	<i>max workable weight Kg</i>
<b>1 - Horizontal lathe</b>					
1.01	POREBA	TCF 224	2009	diam. 2240 X 12000	40.000
1.02	WMW NILES	DP1 S/3	1988/1998	diam. 1900 x 7000	15.000
1.03	G. GIANA	GGL 900	1995	diam. 1600 x 6000	12.000
1.04	L. PONTIGGIA		1960/2007	diam. 1200 x 4000	6.000
<b>2 - Vertical lathe</b>					
2.01	KOLOMNA	1540T	2009	diam. 4000 x 2800	50.000
2.02	KOLOMNA	1532	2000	diam. 3200 x 2000	50.000
2.03	SEDIN	1525	2001	diam. 2500 x 1600	12.000
2.04	ROMAN	SC 22	1991/2004	diam. 2200 x 1500	12.000
2.05	SEDIN	1516	1988/2003	diam. 1600 x 1300	12.000
<b>3 - Millers</b>					
3.01	LAZZATI	HB 150 MM	1979/2003	9000 x 3000	50.000
3.02	TOS	WNH 13.8 C	1990	3500 x 2000	12.000
3.03	FOREST LINE'	P130	1990/2006	2000 x 2000	15.000
3.04	SAN ROCCO	Futura 10	1988/2005	2000 x 1500	6.000
3.05	DEFUM	WF 100 N	1988/1998	1500 x 1100	4.000
3.06	MTE	BF 4200	2002	4000 x 1500	12.000
3.07	FIL	FA 250	1988	2500 x 1300	5.000
3.08	TOS	WHQ 110	2012	2500x1600	8000
<b>4 - Cutter</b>					
4.01	SGM		1980/2006	1500 x 2200	50.000
<b>5 - Bridge crane</b>					
5.01	MARTE		2000		50.000
5.02	TONOLI		2003		16.000
5.03	TONOLI		2002		15.000
5.04	DOVERE		1994		15.000
5.05	MARTE		1998		6.300

Welded & Seamless pipes  
 Hollow forged pipes  
 Deep-bored pipes  
 Pipe spools  
 Manifolds  
 Forgings  
 Flanges  
 Lap Joint Stubends  
 Vessel flanges  
 Contoured nozzles  
 Long WN  
 Tubesheets  
 Swivel, Anchor, Hanger, Misalignment  
 & Hot Tap flanges  
 AWWA flanges  
 Packing & Gaskets  
 Buttweld fittings  
 Pipe bends  
 Piggable fittings  
 Sphere & Flow tees  
 Barred tees  
 Piggable WYE & Lateral tees  
 Buckle Arrestor & J-Lay Collar  
 Power plant fittings  
 Screwed & Socket-weld fittings  
 Branch outlet fittings  
 Ring-joint gaskets  
 Bolts & Nuts  
 Special fasteners & Stud-bolts  
 Patented Quick Opening Closures and Pig Launchers & Receivers  
 Weld-overlaying of flanges, nozzles & fittings

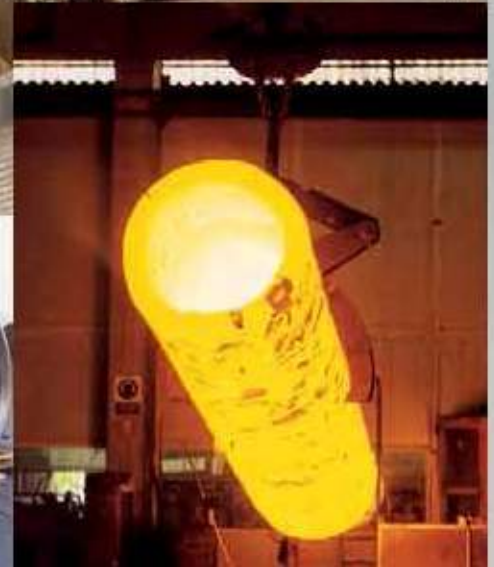

# REFERENCE LIST

## main projects



Year	Product	Material	Project / Country
1990	Fittings, flanges & special nozzles	WPB - A105 LF2	<b>KANGAN PROJECT</b> IRAN
1990	20" anchor flanges with pup pieces	ASTM A694 F60	<b>BRAHMAPUTRA GAS PROJECT</b> BANGLADESH
1991	900 lbs nozzles with w-overlaying	ASTM A350 LF2 + 304L	<b>EPMI SELIGI 'A' GLYCOL PACKAGE</b> MALAYSIA
1991	Large size fittings and flanges	LOW ALLOY	<b>N.W. SHELF DEVELOPMENT</b> AUSTRALIA
1991	Swept nozzles 2" to 20" 600 lbs	ASTM 105	<b>Slug catcher and Inlet separator</b> BRUNEI SHELL PETROLEUM COMPANY
1992	Large size fittings and saddle nozzles	WPHY60 & Y70 WPB & A105	<b>ARCO ONWJ GAS DEVELOPMENT</b> INDONESIA
1992	Fittings, flanges & Spacers	Carbon Steels	<b>UNOCAL ATTAKA 'L' PLATFORM</b> INDONESIA
1992	2" to 10" 600 LBS swept nozzles	A182 F304	<b>PHILIP MORRIS BV - DIET II PLANT</b> NEDERLAND
1992	3" to 30" 900 LBS saddle type nozzles	ASTM A350 LF2.	<b>Slug catcher and Inlet separator</b> ADNA-OPCO
1992	70 tons of buttweild and outlets fittings	ASTM WPB & A105	<b>KHARG TERMINAL</b> IRAN
1993	2" to 24" 600 LBS saddle type nozzles	SA350 LF2.	<b>E.P.M.I.</b> MALAYSIA
1993	Forged fittings & swage nipples	ASTM A105 & A182 F316L	<b>THE LIVERPOOL BAY DEVELOPMENT</b> U.K.
1993	10" 5D pipe bends	WPHY65	<b>PERTAMINA</b> INDONESIA
1993	18" to 24" Anchor Flanges	ASTM A694 F60	<b>KADANWARI PIPELINE &amp; SHIKARPUR LARKANA LOOPLINE</b>
1993	43 tons of welded pipes 1" to 24" OD	TP304L, 316L & 316TI	<b>PT RISJAD BRASALI CHEMINDO</b> INDONESIA
1993	1 x 15 tons saddle type boot	ASME SA105	<b>High pressure separator</b> <b>SINGAPORE REFINING CO. LTD.</b>
1994	30 tons of fittings and flanges.	ASTM A105	<b>NAVAL BASE LIQUID FUEL STORAGE</b> TURKEY
1994	Heavy wall buttweild fittings	WPHY52	<b>JUDY / JOANNE DEVELOPMENT</b> GREAT BRITAIN
1994	100 tons of piping component	Alloy & Stainless Steels	<b>JOHORE</b> MALAYSIA
1994	Large flanges	ASTM A182 F51	<b>SOUTH MORECAMBE TERMINAL</b> U.K.
1994	10 tons of tubing	A269 TP317L	<b>Rigid arm &amp; Riser column.</b> <b>WANASEA &amp; COSSACK PROJ</b> AUSTRALIA
1994	Piping components	Carbon Steels	<b>Water Injection Module</b> <b>WHITE TIGER II FIELD</b> VIETNAM
1994	40 tons of piping component	Carbon Steels	<b>POLYMER &amp; UTILITIES PLANT</b> <b>KARAWANG</b> INDONESIA
1994	Heavy wall buttweild fittings	ASTM A234 WPB	<b>KRANJI SEWERAGE TREATMENT WORKS</b> SINGAPORE
1994	Large size vessel flanges	A182 F304H	<b>FOSTER WHEELER TEXACO</b> U.K.
1994	Heavy wall buttweild fittings	A403 WP 316L	<b>JACKET &amp; TOP SITE</b> <b>SOUTH CHINA SEA</b>

# REFERENCE LIST

## main projects



Year	Product	Material	Project / Country
1994	20 tons of piping components	Carbon Steels	<b>BOTAS NATURAL GAS PIPELINE</b> TURKEY
1995	20 tons of piping components	Carbon Steels	<b>CHIYODA CORPORATION</b> <b>SERAYA CHEMICALS</b>
1995	10 tons of vessel nozzles	BS1503-224-490E LT40	<b>Production separator &amp; coalescer</b> <b>HIGHLAND FABRICATORS (BROWN &amp; ROOT)</b> U.K.
1995	Forged steel fittings & olets	A182 F316 MODIFIED	<b>UREA PLANT</b> INDIA
1995	Heavy wall elbows & hollow pipes	A234 WP22 & A182 F22	<b>CHANDRAPUR 500 MW, UNIT 7</b> <b>BHARAT HEAVY ELECTRICAL LIMITED</b> INDIA
1995	Vessel nozzles & flanges	A182 F11 Class 2	<b>STONE &amp; WEBSTER</b> <b>for GULF OIL REACTOR VESSEL</b> U.A.E.
1995	300 mtr 8" Sch 10S seamless pipe	A312 TP316L	<b>PT. RISJAD BRASALI PEROXIDE</b> <b>CIKARANG, WEST JAVA</b> INDONESIA
1995	Special forged elbows	SA266 CLASS 2	<b>2 x 600 MW COAL FIRE BOILERS</b> <b>STEIN INDUSTRIES - FRANCE</b> U.K.
1995	Bored & machined forged tees	Carbon Steel	<b>HOT TAPPING EQUIPMENT</b> BELGIUM
1995	Special forged nozzles	A105 & A350 LF2	<b>MOBIL OIL INDONESIA INC.</b> INDONESIA
1995	15 tons of pipes, fittings & flanges	Alloy Steel	<b>POWER PLANT</b> <b>PAKA PASIR GUDANG PROJECT</b> MALAYSIA
1995	Fittings & flanges (sizes 20" to 48").	Carbon Steel	<b>THAI PETROCHEMICAL INDUSTRY</b> <b>FLARE STACKRAYONG, MAP TA PHUT</b>
1995	Large size bends	WPHY52	<b>ARBINI PCG PIPELINE - JAVA</b> JAVA - INDONESIA
1996	Trunnions	ASTM A705M-93 Type 630 H1150	<b>NUCLEAR POWER PLANT</b> JAPAN
1996	Large size butt weld fittings & flanges	ASTM A694 F65 & WPHY 65	<b>ARBINI PCG PIPELINE</b> JAVA - INDONESIA
1996	Flanges	ASTM A694 F42, F52 and F65	<b>Metrogas Project</b> <b>VALPARAISO / SAN ANTONIO</b> CHILE
1996	Special concentric reducers	MSS SP-75 WPHY60	<b>Gas &amp; Oil Launchers</b> <b>UNOCAL INDONESIA</b> INDONESIA
1996	50 tons of seamless pipes	A312 TP321	<b>THAI PETROCHEMICAL INDUSTRY</b> THAILAND
1996	Nozzles	BS 1503 - 225 - 490 LT40	<b>AMOCO (UK) EXPLORATION CO.</b> GREAT BRITAIN
1996	Swept Nozzles	ASTM A182 F11	<b>BP ETAP</b> U.K.
1996	Heavy wall butt weld fittings & flanges	MSS SP-75 WPHY60 /A694 F60)	<b>WHITE TIGER II</b> VIETNAM
1996	Special designed nozzles	BS 1503 - 225 - 490 LT40	<b>K.C.C</b> KUWAIT
1996	24" Sch 80 Elbows for pig passage	A420 WPL6	<b>BINTULU CRUDE OIL TERMINAL</b> SARAWAK - MALAYSIA
1996	Fittings & flanges	Carbon steel	<b>TOTAL MYAMMAR PP/QP</b>
1996	Pipes, BW, forged steel & Flanges	A312 TP32, A403 WP32, A182 F321	<b>TUNU NORTH FIELD DEVELOPMENT</b> INDONESIA
1996	24", 36" & 42" anchor flanges	A694 F52	<b>INSTALLATION OF PIGGING FACILITIES</b> <b>ON HP FUEL GAS LINES</b> KUWAIT

# REFERENCE LIST

## main projects



Year	Product	Material	Project / Country
1996	2500 mm OD flanges	SA516 Grade 70.	<b>Reboiler closure TUNU DEVELOPMENT INDONESIA</b>
1997	12000 m of tubes for heat-exchanger	SA213 TP316L	<b>CIKARANG INDONESIA</b>
1997	1000 pieces special nozzles	C22.8 & DIN 17243.	<b>VARIOUS OIL REFINERIES DEUTSCHLAND</b>
1997	28" AWWA flanges	SA516 Gr.60	<b>Recycling waste water in natural gas power plant REPUBLIC OF SOUTH AFRICA</b>
1997	Pipes, fittings & flanges	Low temp. steel	<b>TOTAL BONGKOT FIELD DEVELOPMENT</b>
1997	Piping component	Carbon Steel	<b>AL-SAMEEN FIELD PROJECT MAERKS OIL QATAR</b>
1997	150 tons of heavy forgings	ASTM A105	<b>Tubesheets and vessel flanges INDONESIA</b>
1997	Nozzles to customer's design	BS 1503 - 225 - 490E - LT20	<b>B.P. EXPLORATION (DIMLINGTON) GREAT BRITAIN</b>
1997	900 lbs flanges & nozzles	INCOLOY 825	<b>NSO "A" DEVELOPMENT PROJECT MOBIL EXPLORATION INDONESIA</b>
1997	Spectacle blinds, spades & spacers.	UNS S31803 Duplex A182 F51	<b>MOSSGAS FA GAS COMPRESSION REPUBLIC OF SOUTH AFRICA</b>
1997	Forged bars, rings, & butt weld fittings	ASTM A182 F91	<b>SUTTON BRIDGE POWER PLANT GREAT BRITAIN</b>
1997	Nozzles with weld-overlaying	SA350 LF2 INCOLOY 825	<b>LPG STORAGE SPHERES for PULAU INDAH LPG BOTTLING PLANT MALAYSIA</b>
1997	Reinforced long welding neck	ASTM A350 LF2.	<b>KCC PROCESS EQUIPMENT LTD</b>
1997	1" to 16" pipe	ASTM A333 Gr.6	<b>MALAYSIAN REFINING CO.</b>
1997	From 1/2" to 36" Fittings & Flanges	WPHY60 & ASTM A694 F60.	<b>TUNU NORTH DEVELOPMENT PROJECT INDONESIA</b>
1998	24" & 30" nozzles	BS 1503 - 225 - 490E LT50	<b>Glycol Contractors REINERTSEN VIGOR A.S.</b>
1998	30" to 36" fittings & flanges	WPHY60 & ASTM A694 F60.	<b>TOTAL INDONESIA - EAST KALIMANTAN INDONESIA</b>
1998	BW Fittings, olets & Flanges	WPHY52 & ASTM A694 F52.	<b>SLUG CATCHERS MALAYSIA</b>
1998	38" 300 LBS nozzles	ASTM A182 F304	<b>LNG TANK TRINIDAD &amp; TOBAGO</b>
1998	48" 900 LBS flanges	ASTM A694 F65 & A182 F304.	<b>PECIKO ONSHORE DEVELOP. PROJECT SENIPAH - EAST KALIMANTAN INDONESIA</b>
1998	Monel elbows & monel cylinders	SB366 WPNCS SB564 UNS N04400	<b>Nuclear Power Application ROLLS-ROYCE MARINE POWER LTD.</b>
1998	18" & 20" NPS hubs and test rings	A182 F55 UNS S32760	<b>TROLL 'C' - NORTH SEA NORWAY</b>
1998	6" 900 lbs RTJ orifice flanges	ASTM A105	<b>TUNU NORTH DEVELOPMENT PROJECT INDONESIA</b>
1998	1/2" / 36" OD pipe	A358 Class 1 Grade 321H	<b>PECIKO ONSHORE DEVELOP. PROJECT SENIPAH - EAST KALIMANTAN INDONESIA</b>
1998	H' type saddle nozzles	A707 Class 3	<b>STATOIL NORWAY</b>
1998	20" NS clamp connectors	ASTM A694 F60	<b>VALVE ASSEMBLY NORWAY</b>

# REFERENCE LIST

## main projects



Year	Product	Material	Project / Country
1998	Fittings & flanges	A403 WP321H and A182 F321H	<b>PECIKO ONSHORE DEVELOP. PROJECT SENIPAH - EAST KALIMANTAN INDONESIA</b>
1999	Nozzles for vessel	ASTM A350 LF2	<b>NATIONAL PETROLEUM of ABU DHABI (UAE) U.A.E.</b>
1999	Seamless Shell Barrel, Channel Barrel Special Bolts, Cover Flanges	A182M-95c F22 Class 3	<b>PT. ELNUSA PETRO TEKNIK BALIKPAPAN - INDONESIA</b>
1999	Reinforced nozzles	ASTM A350 LF2	<b>ONSHORE GAS DEVELOPMENT - Phase II ABU DHABI NATIONAL OIL COMPANY</b>
1999	Forgings	TITANIUM Gr 2	<b>NEDERLAND</b>
1999	Centre tube flanges	Wst 1.4306 - DIN 17440	<b>NIKHEF NEDERLAND</b>
1999	18" 900 lbs nozzles	BS 1503 - 225 - 490E LT50	<b>FLEXSYS RUBBER CHEMICALS LTD.</b>
1999	8" & 10" Seamless Crosses	ASTM A234 WPB	<b>MOBIL TERMINAL VIETNAM</b>
1998	40" 600 RF WN	ASTM A 350LF2.	SAUDI ARABIA
1999	Reinforced nozzles	ASTM A350 LF2	<b>ONSHORE GAS DVLP.- Phase II ABU DHABI NATIONAL OIL COMPANY</b>
1999	Heavy WT piping components	Alloy Steels	<b>Santa Rita Combined Cycle Power Station BATANGAS LUZON ISLAND - PHILIPPINES</b>
1999	5D bends	API 5LX gr. 60	<b>Handil Air Injection Pilot Project TOTAL INDONESIA BALIKPAPAN</b>
1999	Heavy Wall Pipe from 1" to 28"	ASTM A106 gr B or A106 gr 60	<b>COGEN NATURAL GAS DEVELOPMENT SINGAPORE</b>
1999	Proof machined forgings	Wst 1.4306 - DIN 17440.	<b>NIKHEF</b>
1999	14 and 24" 1500 "H" type nozzles	BS 1503 - 225 - 490E LT 40	<b>READ PROCESS ENGINEERING LTD U.K.</b>
2000	Studbolts & Nuts	UNS S32760 FLT-SA	<b>NORTH SEA PLATFORM DENMARK</b>
2000	500 tons of piping components	Carbon Steels	<b>WESTERN CANADA</b>
2000	6 metres hollow pipe	BS 1503-622-490E	<b>FERRYBRIDGE POWER STATION GREAT BRITAIN</b>
2000	Reducing Crosses 18" x 10" NPS c/w integral flange	ASTM A694 F52. Fortrex's design & calculation	<b>For Mining Development REPUBLIC OF SOUTH AFRICA</b>
2000	Piping Components	Alloy Steels	<b>COGEN NATURAL GAS POWER PLANT JURONG ISLAND - SINGAPORE</b>
2000	passengers boarding bridges.	Structural steel	<b>Ambon &amp; Manado Airports Expansion INDONESIA</b>
2000	60 tons of vessel flanges & nozzles	Low Temperature	<b>KVAERNER PROCESS SYSTEM ALGERIA</b>
2000	Heavy WT piping components	Y60 - Y65 grades	<b>ANOA Offshore Project INDONESIA</b>
2000	160 tons of forged fittings & outlets	Carbon Steel	<b>Distribution in WESTERN CANADA</b>
2000	Large diametre rings and discs	ASTM A182 F51 (Duplex).	<b>AUSTRALIA</b>
2000	Hot tap cryogenic fittings	WP 304H	<b>Nigeria LNG Expansion Project NIGERIA</b>

# REFERENCE LIST

## main projects



Year	Product	Material	Project / Country
2000	500 tons of piping components	Carbon & Alloy Steels	<b>Inland distribution of natural gas.</b> JURONG ISLAND - SINGAPORE
2000	900 lbs large flanges	ASTM A182 F347	<b>AUSTRALIA</b>
2000	Heavy wall flanges and stud bolts	Carbon Steel	<b>Total Myanmar Filter Relocation</b> NYANMAR
2000	forgings machined to customer's drawings	A182 F6NM	<b>TRANSNUCLEAIRE</b> <b>Transportation of spent nuclear fuel</b> FRANCE
2001	Hollow forgings	BS 1503-660-460	<b>DIDCOTT POWER STATION</b> U.K.
2001	900 & 1500 lbs 'H' type flanges	ASME SA 350 LF2	<b>Allen Process Systems</b> <b>SOUTH PARS</b> IRAN
2001	50 tons of piping components & Wye pieces	Alloy Steels P11 & P22	<b>PANGLIMA CCGT POWER PLANT</b> MALAYSIA
2001	24" heavy nozzle	BS 1503 - 225 - 490E LT50	<b>HALLIBURTON - BROWN &amp; ROOT</b> <b>for and on behalf of BP</b>
2001	20 tons Channel & 7 tons Cover Flanges	ASME SA266 Class 2	<b>KOBE STEEL, LTD.</b> JAPAN
2002	30 tons of fittings & flanges	WPB & WPHY65 A105 & A694 F65	<b>10 WELL CONNECTION</b> INDONESIA
2002	150 tons of Piping Components	A403 WP321H and A182 F321H	<b>PECIKO III ONSHORE DEVELOPMENT PROJ.</b> EAST KALIMANTAN - INDONESIA
2002	Large Diameter Swept Nozzles	BS EN 10333-4	<b>STE Facilities Upgrade Project</b> GREAT BRITAIN
2002	8" to 30" SEAMLESS buttweld fittings	A403 WP304	<b>SENOKO POWER PLANT</b> SINGAPORE
2002	4" to 28" 600 & 900 "H" Type Flanged Nozzle	ASME SA 350LF2	<b>KCG for OGGs</b>
2002	50 tons of Piping Components & Wye pieces	Alloy Steels P11, P22 & P91	<b>PHU MY 3 POWER PLANT</b> VIETNAM
2002	2 x 4 tons / each Lifting Covers	ASTM A105	<b>VGO HT LAG Reactors</b> JAPAN
2002	8" to 24" 600 LBS flanges, bolts&nuts	A182 F304 A193 B8M / 8MA	<b>SENOKO POWER PLANT</b> SINGAPORE
2002	3D Pipe Bends	API 5L X65	<b>BELANAK FIELD DEVELOPMENT</b> INDONESIA
2002	2" to 24" 1500 LBS Swept nozzles	ASME SA508 Grade 3 Class 1	<b>SLP for SHELL GOLDENEYE</b> GREAT BRITAIN
2002	28" x 24" SEAMLESS ECC. REDUCERS	SA350 LF2	<b>Pig Traps - Peciko Back up Line Project</b> <b>TOTALFINALF E&amp;P</b> INDONESIA
2002	25 tons of fittings & flanges	Carbon steels & Duplex S.S.	<b>PECIKO WELL CONNECTION</b> INDONESIA
2002	3D Pipe Bends	API 5L X65	<b>BELANAK FIELD DEVELOPMENT</b> INDONESIA
2002	1 / 2" to 32" vessel nozzles and flanges	SA105N	<b>Final Caustic Wash Tower</b> SAUDI ARABIA
2002	Octagonal RJ Gaskets Bolts & Nuts	Hastelloy C276 & UNS S32760-FLT-SA	<b>Oil Flow Lines</b> <b>TYRA WEST - DANISH SECTOR - NORTH SEA</b>
2003	35 tons of fittings & flanges	Carbon steel	<b>GAS TRANSMISSION &amp; DISTRIBUTION PARALLEL LINES</b> GRISIK - SAKERMAN - INDONESIA
2003	Barred Tees & other piping components	Carbon steel	<b>TUNU NORTH DEVELOPMENT PROJECT</b> INDONESIA



# REFERENCE LIST

## main projects



Year	Product	Material	Project / Country
2003	2" to 24" 600 LBS Nozzles & Flanges	A350 LF2 & 1503-224-490B LT 50	<b>BENDALLS ENGINEERING</b> U.K.
2003	Barred Tees & Eccentric Reducers	MSS SP-75 WPHY 65	<b>ANGSI C &amp; E DEVELOPMENTS</b> MALAYSIA
2003	120 Tons of Piping Components	A403 WP321H and A182 F321H	<b>BONGKOT FIELD DVLP. Phase 3 C</b> THAILAND
2003	42° NB Vessel TEE by 2 meters long	A350 LF2 to be weld-overlaid with SS 904L	<b>SAUDI ARAMCO</b>
2003	Octagonal RJ Gaskets Bolts & Nuts	Hastelloy C276 & UNS S32760-FLT-SA	<b>DAN FG FIELD DEVELOPMENT</b> DENMARK
2003	24" x 14" 600 LBS reducing flanges	ASME SA508 Grade 3 Class 1	<b>KCC</b>
2003	140 Tons of Piping Components	Low Temperature Carbon Steels	<b>OPQL ISDN PHASE II</b> QATAR
2003	Valves, Pipes & Piping Components	Stainless & Low Carbon Steels	<b>OURHOUD PROJECT</b> ALGERIA
2003	140 Tons of Piping Components	Low Temperature Carbon Steels	<b>ERHA FPSO</b> NIGERIA
2003	420 x 160 BORE 600 Eccentric Flanges	ASME SA508 Grade 3 Class 1	<b>SEMBICORP – SIMON CARVES</b> U.K.
2003	2" to 24" 600 LBS Nozzles & Flanges	A350 LF2 & 1503-224-490B LT 50	<b>BENDALLS ENGINEERING</b> U.K.
2003	Extra long reducers to customer's design	SEAMLESS A350 LF2 + NACE	<b>DAN FG FIELD DEVELOPMENT</b> DENMARK
2003	Fittings & Flanges	Carbon steel	<b>TUNU FIELD DEVELOP. PROJECT - PHASE 9</b> INDONESIA
2003	16° NB 90DEG SHORT RADIUS ELBOWS	A420 WPL6	<b>SAUDI ARAMCO</b>
2003	34" & 36" Pipes & Plates	A240 .& A790 UNS S32750	<b>DAN FG FIELD DEVELOPMENT</b> NORTH SEA
2003	400 TONS of flanges 1/2" to 56" 600 lbs	A105 & A694 F70	<b>56" TRANS-IRANIAN GAS LINE</b> IRAN
2003	SEAMLESS fittings 42" x 65 mm WT	A234 WP22 & WP91 90LR ELBOWS & TEE	<b>POWER PLANT FABRICATION</b> CHINA
2003	FORITEX's design 20" Seamless Bar Tee	MSS SP-75 WPHY65	<b>TUNU FIELD DEVELOP. PROJECT - PHASE 9</b> INDONESIA
2004	Stud Bolts & Nuts	Super Duplex UNS S32760 FLT-SA	<b>Dan FG Field Development</b> NORTH SEA
2004	1000 kg Forgings	ASME SA182 F347	<b>Project INCA for BP GRANGEMOUTH</b>
2004	40 Tons of Piping Components	MSS SP WPHY 60 & A694 F60	<b>DOHA PETROLEUM CONTRUCTION CO.</b> DOHA
2004	Spectacle Blinds, Spacers & Drip Rings	Carbon steel & Duplex	<b>Dan FG Field Development</b> NORTH SEA
2004	50 tons of forged rings & discs	Duplex & Super duplex	<b>SOUTH PARS</b> IRAN
2004	42" heavy wall elbows & special reducers	ASME SA234 P91 & ASME SA 182 F91	<b>POWER STATION</b> CHINA
2004	40 tons of Flanges & Weldoflanges	ASTM A182 F51	<b>EAST KALIMANTAN</b> INDONESIA
2004	40 Tons of Piping Components	MSS SP WPHY-60 & A694 F60	<b>DOHA PETROLEUM CONTRUCTION CO.</b> DOHA

# REFERENCE LIST

## main projects



Year	Product	Material	Project / Country
2004	8 pcs Cylinder Shells 1474 OD x 2410 mm LG	ASME SA266 Class 2	PT PUSRI INDONESIA
2004	42 Tons of finish machined nozzles and forged pipes	ASME SA336M - F22 V	1ST & 2ND STAGE REACTORS BABCO LSOP PROJECT
2004	20 pcs 30" x 65 mm WT 90LR ELBOWS	MSS SP-75 WPHY 60	DOHA PETROLEUM CONSTRUCTION CO. DOHA
2004	5 Tons finish machined LIFTING COVER	ASME SA266 Class 2	FLUOR CANADA LTD CANADA
2004	50 Tons of Piping Components	A403 WP321H and A182 F321H	BONGKOT FIELD DVLP. - Phase 3 C THAILAND
2004	Fabricated Special Reducers 26" x 14"	ASME SA516 Gr.70	DAN FG FIELD DEVELOPMENT NORTH SEA
2004	24 Tons DISC 2910 OD x 400 THICK	ASME SA508 Grade 3 Class 1	ROLLS-ROYCE MARINE OPERATIONS LTD U.K.
2004	Flanges and Nozzles for pressure vessel	ASME SA350 LF2 Class 1	PT. SURYA BESINDO SAKTI INDONESIA
2004	2" to 24" 900 lbs Nozzles for pressure vessel	BS1503-25-490-LT50	WHITELEY READ ENGINEERING LTD U.K.
2004	9 Tons of small size heavy wall fittings	ASTM A860 WPHY 60	ERHA FPSO NIGERIA
2004	5 tons of finish machine Rings & discs	ASTM B564 UNS NO 008811	ROLLS-ROYCE MARINE OPERATIONS LTD U.K.
2004	250 tons of fittings & flanges	Carbon, Low temp & High Yield Steels	W.F.F. (CANADA) LTD CANADA
2005	<b>Design, Supply and Coating c/w FINITE ELEMENT ANALYSIS</b> of 3 tons 18" SYMMETRICAL WYE	ASTM A694 F60	TOWNGAS - SHENZHEN to TAI PO SUBMARINE GAS PIPELINE PROJECT
2005	6.2 Tons finish machined LIFTING COVER	ASME SA336M - F22 Class 3	BABCO LSOP PROJECT
2005	18 tons of finish machined rings & discs	ASME SA182 F91 3.2 IBR	BHARAT HEAVY ELECTRICAL LIMITED INDIA
2005	Forged steel, Butt-weld & Branch fittings	ASTM A350 LF6 Cl.2 & LF2 Cl.1	THIRD TRANSMISSION PIPELINE PROJECT OFFSHORE PLATFORM THAILAND
2005	Flanges	ASTM A182 F304H	BURNERS CONSTRUCTION U.K.
2005	30 tons of Nozzles	ASTM A250 LF2 Cl.1	TUNU FIELD Phase 10 TOTAL INDONESIA
2005	35 Tons of finish machined nozzles and forged pipes	ASME SA336M - F22 V	HYDROGENATION REACTORS
2005	Flanges, gaskets, bolts & nuts	ASTM A694 F60 & A182 F51	TOWNGAS - SHENZHEN to TAI PO SUBMARINE GAS PIPELINE PROJECT
2005	75 tons of piping components	MSS SP-75 WPHY52 ASTM A234 ASTM A403 WP304L	UZGEOBURNEFTEGAZDOBYCHA UZBEKISTAN
2005	SEAMLESS 16" & 42" 45 DEG LATERALS	A234 WP91 & WP22	POWER PLANT FABRICATION
2005	11 tons of Flanges & Flangelets	ASTM A105 + A694 F65	KALIMANTAN - INDONESIA
2005	2 tons of API 5000 flanges with INCONEL 625 weld-overlay	ASTM A694 F65 + INCONEL 625	KALIMANTAN - INDONESIA
2005	Nozzles and Necks 2" to 6" 1500 LBS	ASTM A182 F316L	CONOCO-PHILLIPS INDONESIA
2005	Deep-bored pipes 4 to 6 METERS LONG & piping components	BS1503-622-490 E	RATCLIFFE POWER PLANT U.K.

# REFERENCE LIST

## main projects



Year	Product	Material	Project / Country
2006	Bolts & Nuts	Super Duplex UNS S32760 FLT-SA	<b>Various projects 2006</b> Denmark - Qatar
2006	200 tons of proof machined discs and rings	ASTM A 350 LF2	<b>21 Pressure Vessels</b> <b>National Iranian Oil Company</b> IRAN
2006	48 inches Welded Heavy Wall 90°LR Elbows	A234 WPC	<b>POWER PLANT FABRICATION</b> CHINA
2006	11 Tons of Heavy wall welded pipes and buttweld fittings	UNS S 32750	<b>NORTH SEA</b> DENMARK
2006	Heavy Wall flanges 150 lbs to 1500 lbs	ASTM A 182 F5	<b>NORTH SEA</b> DENMARK
2006	300 tons of fittings & flanges	Carbon, Low temp & High Yield Steels	<b>WESTERN CANADA</b> CANADA
2006	INCOLOY 18" 1500 RTJ BLIND with centre hole	ASTM B564 UNS N08825	<b>Water Injection nozzle for BAPCO LSDP PROJECT</b> BAHRAIN
2006	16" & 28" WYE Pieces	ASME SA182 F 91	<b>KOREA</b>
2006	4 TONS of LONG WN	SA182 F316	<b>INDONESIA</b>
2006	Forged Cylinders for Power Plant	BS 1503 621 460	<b>POWER PLANT</b> U.K.
2006	3 Tons of forgings & Stud Bolts	X10CrMoVn9-1	<b>RATCLIFFE POWER PLANT</b> U.K.
2006	Flanges & Forgings for Pressure Vessels	ASTM A182 F53	<b>TOTAL INDONESIA</b> INDONESIA
2006	8 Tons of buttweld fittings up to 24"	A860 WPHY52	<b>TANGE BIJAR PROJECT</b> IRAN
2007	2 x TUBESHEETS OD 3900 mm 19,750 KG/EACH	ASTM A 350 LF2	<b>Pressure Vessel</b> <b>National Iranian Oil Company</b> IRAN
2007	32" heavy wall Elbows Forged & Finish machined discs	ASTM A 234 WP11	<b>THAILAND</b>
2007	FRONT & REAR TUBESHEET Fully machined & drilled	ASTM A182 F53	<b>INDONESIA</b>
2007	320 Tons of fittings, flanges and other piping components size from 1/4" to 36"	A 403 WP 316/316L & A182 F316/316L	<b>CENTRAL PROCESSING PLATFORM TOPSIDE &amp; JACKET - JDA BLOCK B-17 GAS FIELD Dev.</b> MALAYSIA
2007	6 Hollow Forgings 353 OD x 221 mm ID in lengths up to 6100 mm	11CrMo9-10	<b>RATCLIFFE POWER PLANT</b> U.K.
2007	Heavy Wall Elbows of various angles	11 CrMo910	<b>POWER PLANT</b> U.K.
2007	2 x 26" Insulating Joints + 3 Tons of fittings, olets & gaskets	API 5L X60 A105, F316 & A234 WPB	<b>26° AHVAZ PROJECT</b> IRAN
2007	Weldoflanges & other piping components	ASTM A182 F51	<b>PAKISTAN</b>
2007	Bolts & Nuts	Super Duplex UNS S32760 FLT-SA	<b>Various projects 2007</b> Denmark - Qatar
2007	18" x 12" Seamless Tee 50.53 mm WT	ASTM A815 S31803	<b>GUNTONG E &amp; TAPIS F platforms</b> TERENGGANU - MALAYSIA
2007	900 LBS Flanges 10.000 API Flanges & Weldoflanges	A694 F52 A182 F51	<b>JGC - DESCON ENGINEERING - MIANO 11</b> PAKISTAN
2007	2" to 24" heavy "H" type nozzle for pressure vessels	ASTM A105N	<b>BP Dimlington Refinery</b> U.K.
2007	42" 90DEG ELBOW with 30mm min. WT	ASME SA234 WPC	<b>POWER PLANT FABRICATION</b> CHINA

# REFERENCE LIST

## main projects



Year	Product	Material	Project / Country
2007	900 LBS Flanges	A694 F52	<b>FOSTER WHEELER PETROLEUM KADANWARI FIELD DEVELOPMENT</b> PAKISTAN
2007	2 Tons of fittings, flanges & Anchor flanges designed by FORITEX	MSS SP-75 WPHY52 & A694 F52	<b>27 NAR PROJECT</b> IRAN
2007	2" to 24" 600 LBS Nozzles & Flanges	A350 LF2 with special requirements	<b>JACOB'S ENGINEERING</b> HOLLAND
2007	10" Seamless pipes 4" seamless, 6" & 8" welded pipes	A333 Gr.6 A790 UNS S31803	<b>WELLHEAD DEVELOPMENT PROJECT</b> <b>SAWAN 11, 13 &amp; 14</b> PAKISTAN
2007	Forgings, "H" Type Nozzles & Flanges	A105N & A350 LF2	<b>TOTAL INDONESIA</b>
2007	4 tons of forgings	ASTM A182 F91	<b>INDIA</b>
2007	4 x 8" Insulating Joints + 18 Tons of fittings, flanges & Anchor flange designed by FORITEX	API 5L X52 MSS SP-75 WPHY52 A694 F52	<b>23 &amp; 30 KANGAN PROJECT</b> IRAN
2007	16" & 20" Seamless pipes flanges & fittings Self reinforced nozzles	API 5LX52 WP316L,WPL6, WPHY52 SA 105N	<b>IRAN</b>
2008	48" & 42" Anchor Flanges designed by FORITEX	A694 F70 & F60	<b>GAZODUC MED-GZ4 48" PHASE III</b> ALGERIA
2008	seamless pipes 8" Sch 80S 180 metres	A790 UNS S31803	<b>WELLHEAD DEVELOPMENT PROJECT</b> <b>SAWAN 11</b> PAKISTAN
2008	180°SR Return Bends & 90°SR Ebows flanges	A234 WP9 A182 F9	<b>IRAN</b>
2008	24" & 18" Barred Tees designed by FORITEX	MSS P-75 WPHY65 & Y52	<b>CPOC JDA Block-17 DEVELOPMENT</b> <b>Central Production Complex Facilities</b> THAI-MALAYSIA JOINT DEVELOPMENT AREA
2008	8" SEAMLESS 5D & 10D Pipe Bends	ASTM A815 UNS S31803	<b>JGC - DESCON ENGINEERING - SAWAN 14</b> PAKISTAN
2008	Bolts & Nuts	Super Duplex UNS S32760 FLT-SA	<b>Various projects 2008</b> DENMARK - QATAR
2008	56 pieces Heavy Wall Elbows of 216 mm ID and 406 mm ID	14MOV6.3	<b>RATCLIFFE POWER PLANT</b> U.K.
2008	14 tons of 1/2" to 24" flanges 300 and 600 LBS	ASTM A105 & A182 F22	<b>ABADAN REFINERY</b> IRAN
2008	280 tons of butt-weld fittings & flanges	Carbon, Low Temp & High Yield Steels	<b>WESTERN CANADA</b>
2008	28" x 24" 53 mm WT x 620 mm LG SEAMLESS concentric reducer	ASTM A234 W22 Cl. 1	<b>SINGAPORE</b>
2008	Heavy Wall welded pipes, fittings flanges and olets	A790 UNS S31803 & ASTM A815 UNS S31803	<b>ZAMZAMA GAS PLANT</b> PAKISTAN
2008	Finish machined nozzles to customer's design	14MOV6.3	<b>RATCLIFFE POWER PLANT</b> U.K.
2008	2" to 24" 600 LBS Nozzles & Flanges	A350 LF2 and additional requirements	<b>UNITED KINGDOM</b>
2008	20 tons of Flanges & Flangeolets	ASTM A182 F51 ASTM A105	<b>KALIMANTAN</b> INDONESIA
2008	Metallic Gaskets	HASTELOY C276	<b>Various projects</b> DENMARK - QATAR
2009	Complete package of forged steel & buttweld fittings	ASTM A815 WP-S32760 A403 WP-S31254 A403 WP316L	<b>HALFDAN B PHASE IV Development</b> DENMARK
2009	Drop-forged valve components	C22E	<b>Gas distribution</b> FRANCE
2009	Pipes, fittings, flanges of various sizes and pressure ratings	A403WP316/316L A403WP-S31803 A182 F51, F316L	<b>WELLHEAD DEVELOPMENT PROJECT</b> <b>SAWAN 10 &amp; 15 - PAKISTAN</b>

# REFERENCE LIST

## main projects



Year	Product	Material	Project / Country
2009	Complete package of Flanges	ASTM A105 & A350 LF2 A182 F44, F53-55 , F316L	<b>HALFDAN B PHASE IV Development</b> DENMARK
2009	Complete package of Stud Bolts & Nuts	Super Duplex UNS S32760 FLT-SA UNS S32760 FG-SA	<b>HALFDAN B PHASE IV Development</b> DENMARK
2009	12 tons of SEAMLESS Lap Joint Stubends	A403 WP-S31254	<b>HALFDAN B PHASE IV Development</b> DENMARK
2009	20 tons of proof machined forged blocks 2800 mm LONG	P355 QH TUV 354/3 ad WO/W10/W13	<b>EXXON-MOBIL</b> <b>production facilities</b>
2009	Stud Bolts & Nuts	Super Duplex UNS S32760 FLT-SA	<b>Various projects 2009</b> DENMARK - QATAR
2009	Buttweld fittings, flanges weldoflanges and olets gaskets	A403WP316/316L A403WP-S31803 A182 F51, F316L	<b>LATIF-2 PROJECT</b> PAKISTAN
2009	Complete package of Drip Rings	ASTM A350 LF2 A182 F44, F316L	<b>HALFDAN B PHASE IV Development</b> DENMARK
2009	Flanges	SA182 F304L & SA105	<b>IRAN</b>
2009	Pipes, fittings, flanges, bolts, nuts, oval and spiral wound gaskets	WPB, A105, A193/194 SOFT IRON	<b>GAZODUC MED-GZ4 48" PHASE III</b> ALGERIA
2009	Super Duplex Stud Bolts & Nuts	UNS S32760 FLT-SA	<b>HALFDAN B PHASE IV Development</b> DENMARK
2009	2" to 24" Self Reinforced nozzles	ASME SA350 LF2	<b>NIGERIA</b>
2009	Critical Flow Nozzle	ASME SA304H	<b>UNITED KINGDOM</b>
2010	Forged Elbows for power plant	EN10222-2 14MoV6.3	<b>FEERYBRIDGE POWER STATION</b> UK
2010	20 tons of Flanges	A182 F51 UNS S31803	<b>BHP Petroleum (Pakistan) PTY LTD</b> PAKISTAN
2010	Forged Rings for Pig Launchers and Receivers	A694 F52 A182 F51 UNS S31803	<b>SNAM RETE GAS</b> ITALY
2010	Bonnet and Nozzle forgings for High Pressure Boiler	ASME SA182 F91	<b>BHARAT HEAVY ELECTRICALS Ltd.</b> INDIA
2010	Finish machined pipes and nozzles for power plant boiler	EN10222-2 13CrMo4-5	<b>ALSTOM c/o Boilers Factory SEFAKO S.A</b> POLAND
2010	Fittings, Flanges and Pipes	A333 Grade 6 - A106-B A234 WPB - A105	<b>BHP Petroleum (Pakistan) PTY LTD</b> DEBOTTLENECKING PROJECT
2010	Hollow Forgings	ASTM A182 F22	<b>Nuclear civil application</b> UK
2010	Stud Bolts & Nuts	A193 Grade B8/B8M/B8T A194 Grade 6/8/8M/8T	<b>SHIRAZ REFINERY</b> IRAN
2010	40 Tons of finish machined Tubesheets & Shell Flanges	ASME B564 Gr.1 Ed.06a UNS N06625	<b>CASTOR UGS DEVELOPMENT</b> SPAIN
2010	<b>Design, Fabrication and Coating</b> of J-TUBE BELLMOUTHS	A694 F52	<b>KIPPER TUNA RISE ACCES TOWER</b> AUSTRALIA
2010	Fittings, Flanges and Pipes	A403WP316/316L A403WP-S31803 A182 F51, F316L	<b>ZAMZAMA FRONT END COMPRESSION PROJECT</b> PAKISTAN
2010	SUPER DUPLEX Stud Bolts & Nuts and Gaskets	UNS S32760 FLT-SA INCONEL 625	<b>Various projects 2010</b> DENMARK - QATAR
2010	Duplex and Cupronickel Forged Steel and Buttweld Fittings	ASTM A815 UNS S31803 EN 12449 CW352H Cu-Ni	<b>KALIMANTAN</b> INDONESIA
2010	Socket-weld Forged Steel Fittings & Branch Fittings	TITANIUM ASTM B381 Grade F-2 & INCOLOY ASTM B564 UNS N08825	<b>4th NGL Project</b> U.A.E.

# REFERENCE LIST

## main projects



Year	Product	Material	Project / Country
2010	<b>Design, Fabrication and Coating c/w FINITE ELEMENT ANALYSIS</b> of 16" SYMMETRICAL PIGGABLE WYE	ASTM A105N	<b>STX OFFSHORE &amp; SHIPBUILDING CO LTD</b> Korea External Turret Mooring System - CHINA
2010	Duplex Pipes and Flanges	ASME SA790 UNS S31803 ASME SA 182 F51	<b>PETROLEUM DEVELOPMENT OMAN</b> AIR COOLED HEAT EXCHANGERS
2010	Monolithic Insulation Joint	A694 F52 / API5L X52	<b>SEMBCORP GAS PTE LTD</b> ORF Modification for GSA-2 Project
2011	24" 90°LR ELBOWS x 60 mm WT	ASTM A403 WP 321 -S Seamless	<b>HYDROCRAKER PACKAGE</b> YANBU EXPORT REFINERY - SAUDI ARABIA
2011	Driving Heads for wind mills	ASTM A694 F52	<b>4GW Hornsea offshore wind farm</b> off the Yorkshire coast - UNITED KINGDOM
2011	Flanges	Incoly 825 - UNS N08825	<b>Gas Sweetening Facilities</b> SRU project
2011	28 tons of Drop-forged valve bodies	EN10222-2 P245 GH+N	<b>Gas distribution</b> FRANCE
2011	40 tons Bonnet and Nozzle forgings for High Pressure Boiler	ASTM A182 F91	<b>POWER PLANT</b> INDIA
2011	Flanges, neck forgins and fittings	Incoloy 825 - UNS N08825	<b>SCOT &amp; BUGIS PROJECT</b> SHELL Eastern Petroleum, Pulau Bukom, SINGAPORE
2011	Girth and Blind Vessel Flanges	ASTM A182 F51 - DUPLEX NORSOK Standard	<b>AKER PROCESS SYSTEMS AS</b> NORWAY
2011	Finish machined & drilled Tubesheets Nozzles - 36" and 60" WN & BLIND	ASME SA182 F316L	<b>PERTAMINA</b> INDONESIA
2011	Customised 24" and 28" WN flanges for J Transition Pieces	ASTM A694 F52	<b>OIL STATES</b> for E.ON RUHRGAS - HUNTINGTON FIELD - UK
2011	HP Steam Strainer Body	EN 10222-2 Grade 14MoV6-3	<b>LOY YANG POWER STATION</b> AUSTRALIA
2011	Nozzles, Long WN and Flanges	A350 LF2	<b>HEAT EXCHANGER</b> IRELAND
2011	12 & 14" 90°LR ELBOWS x 40 / 42 mm WT	ASME SA182M F347 Seamless	<b>HDT REACTOR</b> SK LUBRIFICANTS CO. LTD. - KOREA
2011	Customs design Elliptical subsea flanges	ASME SA182 F51 UNS S31803	<b>U.S. NAVY</b> Submarine Application
2011	<b>Design and Fabrication</b> of 26" SWIVEL, WN & HANGER FLANGES	ASTM A694 F65	<b>BIEN DONG 1 PROJECT</b> VIETNAM
2011	<b>Design and Fabrication c/w FINITE ELEMENT ANALYSIS</b> of 26" SYMMETRICAL PIGGABLE WYE	ASTM A694 F65	<b>BIEN DONG 1 PROJECT</b> VIETNAM
2011	100 Tons of finish machined nozzles	ASME SA336M - SA182M GRADE F22V	<b>REACTORS &amp; SEPARATORS</b> TUPRA IZMIT REFINERY TURKEY
2012	Seamless Barred Tees with EN10204 - 3.2 certificates	A860 WPHY65	<b>HST FULL FIELD AND HSD EARLY PRODUCTION SYSTEM DEVELOP. PROJECT</b> VIETNAM
2012	Long WN Flanges	ASME SA182 F44 - F316L & SA350 LF2 CI.1	<b>SHAYBAH NGL PROJECT - SAUDI ARAMCO</b> AIR COOLED HEAT EXCHANGERS
2012	30 tons of rough machined forgings	EN 10222-2 Grade 14MoV6-3 N&T	<b>Yallourn Power Station</b> AUSTRALIA
2012	Lap Joint STUB ENDS	A403 UNS S31254	<b>Various projects 2012</b> DENMARK
2012	SS Flanges	ASME SA182 F316L	<b>WASIT GAS PROJECT - SAUDI ARAMCO</b> AIR COOLED HEAT EXCHANGERS
2012	Nozzles, Long WN & Cover flanges for HEAT EXCHANGERS	ASTM A765 Grade II & SA350 LF2 CI.1	<b>The Shell Petroleum Development Company of Nigeria Limited</b> OBEN GAS PLANT - NIGERIA
2012	Proof Machined Forgings	AISI 4140	<b>THE JAPAN STEEL WORKS LTD</b> YOKOHAMA PLANT - JAPAN

# REFERENCE LIST

## main projects



Year	Product	Material	Project / Country
2012	Hemispherical Heads, Nozzles, Long WN & Flanges	ASME SA366 F22 & F5 + <b>SS347 Weld Overlay</b>	<b>PERTAMINA DUMAI REFINERY</b> Units Combined Feed Exchanger - INDONESIA 5
2012	Pig Launchers & Receivers 22"x 18" 600# / 32" x 28" 1500#	ASTM A694 F65 Seamless	<b>ZAWTIKA DEVELOPMENT PROJECT</b> MYANMAR
2012	Monel elbows	SB564 UNS N04400 Monel	<b>Nuclear Power Application</b> <b>ROLLS-ROYCE MARINE POWER OPERATIONS</b>
2013	48" & 52" Heavy Wall TEES & ELBOWS total supply 300 tons	MSS SP-75 WPHY60 MSS SP-75 WPHY65	<b>SLUG CATCHERS</b> Pakistan
2013	VALVES BODY FORGINGS	ASME SA182 F53 SUPER DUPLEX	<b>API 6A/ ISO 10423 PSL 1-3 pressure equipment</b> USA
2013	Pipe, Fittings & Flanges	CS, SS, Duplex	Varios projects <b>LATIF- SAWAN - KANDANWARI</b> PAKISTAN
2013	28 tons of Drop-forged valve bodies	EN10222-2 P245 GH+N	<b>Gas distribution</b> FRANCE
2013	Girth Flange + Flanges	MONEL 400	WESTERN AUSTRALIA
2013	Flanges & Pipes	Incoloy 825 & Duplex	<b>Varios Projects</b> AIR COOLED HEAT EXCHANGERS
2013	SPECIAL FITTINGS	MODIFIED F304L	<b>UK Royal Navy</b> BAE SYSTEMS
2013	<b>Design and Fabrication c/w FINITE ELEMENT ANALYSIS</b> of 26 INCH Anchor + WN + Blind Flanges	A694 F70	<b>SASOL</b> <b>ROMPCO Loop Line Expansion Project</b> MOZAMBIQUE
2013	Lap Joint STUB ENDS	A403 UNS S31254	<b>Varios projects 2013</b> DENMARK
2013	<b>Design and Fabrication c/w FINITE ELEMENT ANALYSIS</b> of SWEEP BRANCH OULET FITTING	ASTM A182 F321 & ASTM A105	<b>Varios projects</b> EGYPT
2013	26 INCH Barred Tee & Fittings	MSS SP-75 Grade WPHY-70	<b>SASOL</b> <b>ROMPCO Loop Line Expansion Project</b> MOZAMBIQUE
2013	<b>Design and Fabrication c/w FINITE ELEMENT ANALYSIS</b> of 12 INCH x 10 INCH ASYMMETRICAL PIGGABLE WYE	ASTM A182 F51 DUPLEX	<b>HUSKY ENERGY</b> <b>South White Rose Extension Project</b> CANADA
2014	<b>Design and Fabrication c/w FINITE ELEMENT ANALYSIS</b> of 20 INCH and 42 INCH WELDED Y-TEE	ASTM A358 TP304/304L	<b>PUSRI 2B AMMONIA UREA PROJECT</b> INDONESIA
2014	VALVES BODY FORGINGS	ASME SA182 F53 SUPER DUPLEX	<b>NATIONAL OILWELL VARCO</b> <b>API 6A/ ISO 10423 PSL 1-3 pressure equipment</b> USA
2014	FITTINGS, FLANGES HOLLOW FORGINGS & PIPES	ASME SA182 F317L / F321 ASME SA312 TP 321 ASME SA403 WP-S-317 / 317L	<b>HEAT EXCHANGERS</b> CANADA
2014	Finish machined pipes and nozzles for power plant	EN 10222-2 11CrMo9-10	<b>COTTAM POWER STATION</b> UK
2014	24" NPS Sch 60 (24.61 mm AWT) SEAMLESS PIPE	A358 UNS S31254 254SMO@ 6moly, 6MO	<b>NORTH SEA</b> DENMARK
2014	MONOLITHIC INSULATING JOINTS	A694 F52 API 5L X52	<b>LPG TERMINAL &amp; BOTTLING PLANT</b> BANGLADESH
2014	<b>Fabrication of PIPESPOOLS</b> c/w HYDROSTATIC testing	ASTM A350 LF2 & LF6	<b>Thai Binh Gas Field Development Project</b> VIETNAM
2014	<b>Design and Fabrication c/w FINITE ELEMENT ANALYSIS</b> of 6 INCH and 24 INCH TRANSITION JOINTS	ASTM A182 F304H + ASTM B564 UNS N08800 + ASTM A182 F11/F91	<b>PUSRI 2B AMMONIA UREA PROJECT</b> INDONESIA
2014	MONOLITHIC INSULATING JOINTS	A694 F60 API 5L X60 PSL2	<b>VIETSOPETRO - PETROVIETNAM</b> <b>mod. at WHITE TIGER FIELD TO RECEIVE GAS FROM THIEN UNG, DAI HUNG FIELDS</b>
2014	<b>Design and Fabrication of</b> SWIVEL & BALL / MISALIGNMENT FLANGES	ASTM A694 F52 ASTM A694 F60	<b>GULF OF MEXICO</b>
2014	Design and Fabrication c/w <b>FINITE ELEMENT ANALYSIS</b> of 20 INCH ASYMMETRICAL PIGGABLE WYE	ASTM A350 LF2 Cl.1 plus welding of PUP PIECES of material grade L360MB	<b>STUBLACH GAS STORAGE FACILITY</b> UK

# REFERENCE LIST

## main projects



Year	Product	Material	Project / Country
2014	<b>Design and Fabrication c/w FINITE ELEMENT ANALYSIS</b> of 16 INCH ASYMMETRICAL PIGGABLE WYE and WN, SWIVEL, BALL / MISALIGNMENT & HOT TAPABLE FLANGES and supply of HOT INDUCTION BENDS	WYE: ASTM A694 F60 FLANGES: ASTM A694 F60 <b>+ Inconel 625 W/O of RJ</b> BENDS: API X60 PSL2	<b>PETROVIETNAM</b> <b>DAI HUNG GAS GATHERING PROJECT</b> VIETNAM
2014	Bolts & Nuts	Super Duplex UNS S32760 FLT-SA	<b>Various projects 2014</b> DENMARK - QATAR
2015	80 Tons of finish machined nozzles	ASME SA336M - SA182M GRADE F22V	<b>REACTORS &amp; SEPARATORS</b> STAR RAFINERI A.S. - TURKEY
2015	WN & BLIND Flanges 1500#	Incoloy 825	<b>PETROFAC</b> <b>CLEAN FUEL PROJECT</b>
2015	20 inch BW FITTINGS	ASTM A860 WPHY52 & 60	<b>HEBRON OFFSHORE PROJECT</b> CANADA
2015	WN, BLIND & LWN Flanges	ASME SB462 N08367 ASME SB564 N08825 ASME SA182 F60	<b>SAUDI ARAMCO</b> <b>JAZAN REFINERY &amp; TERMINAL PROJECT</b>
2015	Forged Barrels, Nozzles and Special Eccentric Reducers	ASTM A350 LF2 Cl.1	<b>TOTAL EGINA FPSO</b> NIGERIA
2015	Design and Fabrication of 26 inch 1500# WN, Spade & Spacer and Barred Tee	ASTM A694 F65 / A860 WPHY65 <b>+ Inconel 625 W/O of RJ</b>	<b>BK-TNG WELLHEAD PLATFORM</b> VIETNAM
2015	36 x26 inch SEAMLESS BARRED TEE	MSS SP-75 WPHY65 Q+T	<b>PDVSA - CAMPO DRAGON</b> VENEZUELA
2015	<b>Design and Fabrication c/w FINITE ELEMENT ANALYSIS</b> of 5 and 6 inch ASYMMETRICAL PIGGABLE WYE	ASTM A694 F65	<b>PT FREEPORT INDONESIA</b> Grasberg minerals district - INDONESIA
2015	Procurement and Fabrication of 24 INCH 900# TEMPORARY PIPE SPOOL	ASTM A694 F65	<b>SHELL</b> Amberjack Pipeline
2016	Finish machined Nozzles for Pressure Vessels	ASME SA182 F1 ASME SA350 LF2	<b>PRESSURE VESSEL</b> SPAIN
2016	Vessel Flanges	TITANIUM ASME SB381 Grade F2	<b>PRESSURE VESSEL</b> INDONESIA
2016	20 & 28" Forged Tee, Cap and Elbow	ASME SA366 F22	<b>HEAT EXCHANGER</b> SPAIN
2016	<b>Design and Fabrication</b> of 16 INCH BALL / MISALIGNMENT FLANGES and accessories	ASTM A694 F65 <b>+ Inconel 625 W/O of RJ</b>	<b>PETROVIETNAM GAS CORPORATION J.S.C</b> <b>SSIV SKID IN BACH HO FIELD</b> VIETNAM
2016	50 Tons of Forged Half Cones	EN 10028-2 P265GH	<b>SIEMENS</b> POWER PLANT
2016	<b>Design and Fabrication c/w FINITE ELEMENT ANALYSIS</b> 26" Riser Hang-off Flanges and test ring	ASTM A694 F65	<b>BPTT Angelin Project</b> Trinidad and Tobago
2016 & 2017	Complete package of Stud Bolts & Nuts (120 tons)	<b>Super Duplex</b> ASTM A276 UNS S32760 FLT ASTM A276 UNS S32760 FG <b>Alloy</b> ASTM B446 (UNS N06625) <b>Carbon Steel</b> A320 GRL7/ A194/7L	<b>CULZEAN FIELD DEVELOPMENT PROJECT</b> Maersk Oil North Sea UK Limited UK
2017	HOLLOW FORGING for Power Plant	ASTM A105N / SA266 Gr.2	<b>MILLMERRN POWER STATION</b> AUSTRALIA
2017	<b>Design and Calculation</b> of 12" & 36" ANCHOR Flanges	ASTM A694 F60 & F70	<b>TAQA Atrush BV</b> <b>Atrush Pipeline Export System</b> IRAQ
2017	10" & 12" PIPE WELDED	A928 Cl.1 UNS S31803 DUPLEX	<b>SOUTH WEST MIANO BLOCK</b> PAKISTAN
2017	12" & 18" ELBOWS 90° LONG RADJUS with 200 mm TANGENTS	EN10222-2 Grade 14MoV6-3	<b>YALLOURN W POWER PLANT</b> AUSTRALIA



# REFERENCE LIST

## main projects



Year	Product	Material	Project / Country
2017	26" BARRED TEE including <b>Hydrostatic Test</b>	ASTM A860 WPHY65	<b>BPTT Angelin Project</b> Trinidad and Tobago
2017	<b>Design and Fabrication</b> of 72" & 90" OD <b>VESSELETS</b>	ASTM A182 F321H	<b>Saudi Polyolefins Company</b> Kingdom of Saudi Arabia
2017	<b>High Pressure Autoclaves Body and Covers</b> Cat. IV as per DESP and fabricated according to CODAP 2015	ASME SA 564 Gr 630 type 1150	<b>TOP INDUSTRIE SAS</b> France
2017	<b>Design and Fabrication</b> of 36, 28 & 16 INCH Lateral Tees, Sweepolets, Bends & Reducers	ASTM A182 F304 AISI 304	<b>JSC Yamal LNG</b> <b>Liquefied Natural Gas Plant</b> <b>South Tambej Field</b> Russia
2017	<b>Design and Fabrication c/w</b> <b>FINITE ELEMENT ANALYSIS</b> of 20 INCH ASYMMETRICAL PIGGABLE WYE	ASTM A350 LF2 Cl.1 plus welding of PUP PIECES of material grade L360MB	<b>STUBLACH GAS STORAGE FACILITY</b> PHASE 2 Project UK
2017	<b>Design and Fabrication c/w</b> <b>FINITE ELEMENT ANALYSIS</b> of 8, 12 & 16 INCH WN, SWIVEL, BALL / MISALIGNMENT FLANGES	ASTM A694 F60	<b>VIETSOPETRO</b> <b>AT CA TAM OIL FIELD</b> Vietnam
2018	<b>Design and Fabrication</b> of ANCHOR Flanges & Supply of Barred Tees, Bends, BW Fittings, Flanges, Bolts & Nuts	MSS SP-75 WPHY-60 / 65 ASTM A815 Gr. UNS S31803 ASTM A694 F60 / 65 ASTM A182 F51	<b>SONATRACH - FCP (OC)</b> <b>Block 405b</b> <b>Central Area Field Complex (CAFC) facilities</b> ALGERIA
2018	2" & 14" 1500 WN, Blind Flanges & Test Rings	ASTM A694 F52 / F65 <b>with Inconel 625 Weld Overlay</b> <b>&amp; NORSOK M501 system 7C coating</b>	<b>Tulip Oil Netherlands BV</b> <b>flanges for a 43 km 14" gas pipeline with 2" Methanol injection</b> <b>line for Q10 - P15 gas field NEDERLAND</b>
2018	<b>Design and Fabrication c/w</b> <b>FINITE ELEMENT ANALYSIS</b> of 2, 10, 12, 20 & 26 INCH of WN, BLIND & SWIVEL FLANGES	ASTM A694 F65 <b>with Multi-Purpose Polyamide Epoxy</b> <b>coating</b>	<b>Terang Sirasun Batur (TSB)</b> <b>offshore gas fields in the Bali Sea</b> INDONESIA
2018	<b>Design &amp; Supply</b> of 20 x 10 INCH FORGED CONICAL SHAPE REDUCERS	ASTM A350 LF2 Cl.1	<b>STUBLACH GAS STORAGE FACILITY</b> PHASE 2 Project UK
2018	<b>Design and Fabrication c/w</b> <b>FINITE ELEMENT ANALYSIS</b> of 20 INCH ASYMMETRICAL PIGGABLE WYE and Assembly of Pipe Pus and Flanges <b>HYDROTESTED</b>	ASTM A694 F65 SOUR SERVICE	<b>PEMEX</b> CONSTRUCTION OF TWO SUBSEA PIPELINES OF 20" Ø IN THE XANAB FIELD, IN THE PROBE OF CAMPECHE GULF OF MEXICO

Welded & Seamless pipes  
Hollow forged pipes  
Deep-bored pipes  
Pipe spools  
Manifolds  
Forgings  
Flanges  
Lap Joint Stubends  
Vessel flanges  
Contoured nozzles  
Long WJ  
Tubesheets  
Swivel, Anchor, Hanger,  
Misalignment & Hot Tap flanges  
AWWA flanges  
Packing & Gaskets  
Pipe Spools

Buttweld fittings  
Pipe bends  
Piggable fittings  
Sphere & flow tees  
Barred tees  
Piggable WYE & Lateral tees  
Buckle Arrestor & J-Lay Collar  
Power plant fittings  
Screwed & Socket-weld fittings  
Branch outlet fittings  
Ring-joint gaskets  
Bolts & Nuts  
Special fasteners & Stud-bolts  
Patented Quick Opening Closures and  
Pig Launchers & Receivers  
Weld-overlaying of flanges,  
nozzles & fittings

---

quality and service for business

---



FORITEX S.r.l.  
Via Emilia Piacentina 12  
29010 SARMATO PC  
ITALIA

telephone +39 0523 886164  
telex +39 0523 886171  
e-mail [foritex@foritex.it](mailto:foritex@foritex.it)  
website [www.foritex.it](http://www.foritex.it)