



Design and
construction of heat
treatment plants

HI-TECH ENGINEERING SRL

Heat treatment installation of steel or aluminum parts, at raw state, forged, cast or die-cast state.

About Us

- Hi-Tech engineering is based in Turin, the heart of the Italian automotive industry and a reference point for the medium and small series forging sector.
- We are a small-to-medium sized company of about 15 **highly qualified professionals**, each with established specialized skills.
- We offer an integrated service thanks to a **multi-disciplinary team** capable of covering all project phases: from **conception and mechanical design**, to the **development of electrical diagrams, PLC programming, construction and commissioning** of installations.



Company information

Italian company, based in Turin



Our Mission

"TURNKEY" IS BOTH SERVICE AND COMPANY PHILOSOPHY

- In-house technical study.
- Assembly in our factory
- Shipping
- Reassembly at customer site
- Commissioning and production start-up
- 24-month warranty



Our customers

Who are the recipients of our tailor-made plants

Customized installations

Our company does not have a catalogue; we design customized installations tailored to our customers' needs. We are able to adapt our layouts to the existing spaces and restrictive requirements of our customers.

Stamping, forging or rolling companies.

Steelworks or foundries.

Third-party heat treaters.

Our customers

- Customers who have never had an in-house heat treatment process;
- Customers who need to retrofit existing heat treatment lines;
- Those who have difficulty achieving certain heat treatment targets;
- Customers who wish to improve their processes or add new ones;
- Who want to add new parts to their production.

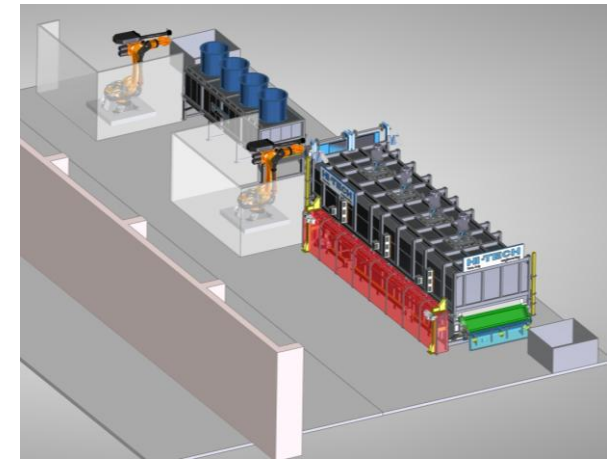
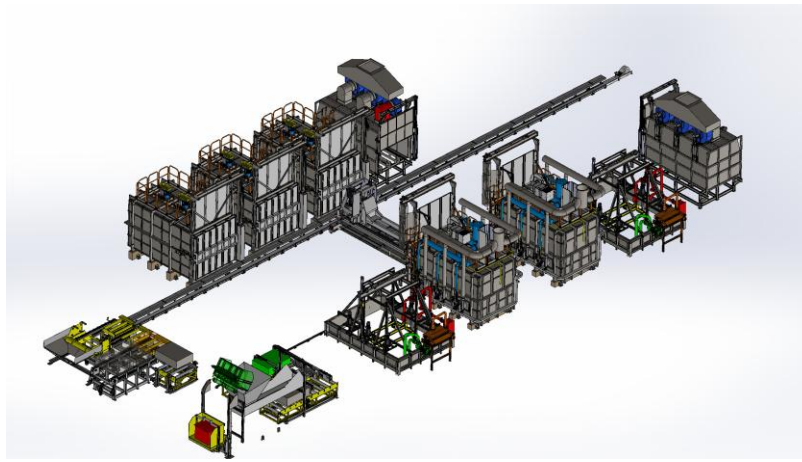

Our know-how

Our systems for every need

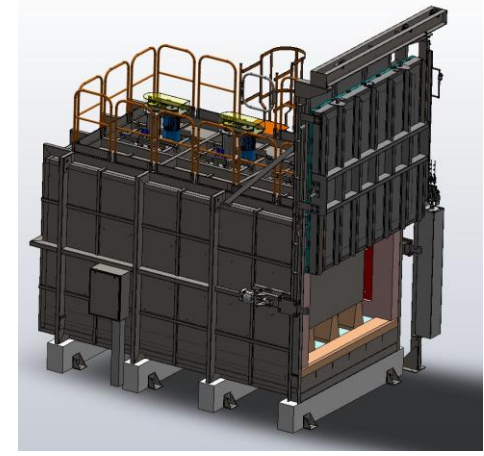
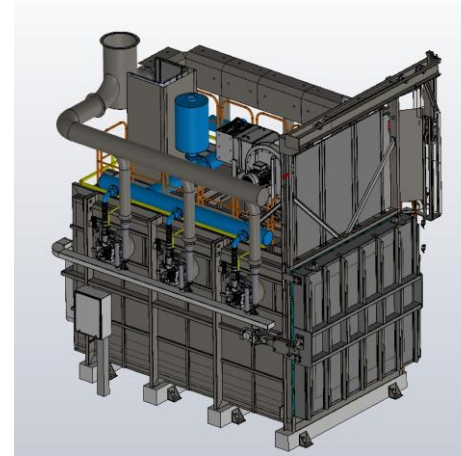
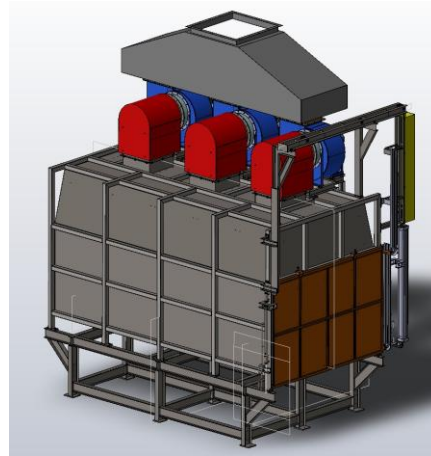

Plants that adapt to production and layout requirements

• Box Type Furnaces

- Furnaces for temperatures between 200°C and 1100°C, for variable processes, and modular productivity



Modularity



• Roller Type Furnaces

- Furnaces for hardening, isothermal annealing, normalising, between 200°C and 1050°C, for more continuous processes



Continuity of production



• Charging machines

- Fully automatic or semi-automatic machines serving batch lines; capacities between 2-30 t.



Automation



• Other machines

- Automatic loading systems, shot blasting machines, robot loads, accessories



Completion of the supply



Our added values

Some specificities of our product or service

Roller furnaces up to 1050°C

Modular lines with multi-purpose furnaces

Pilot and test lines

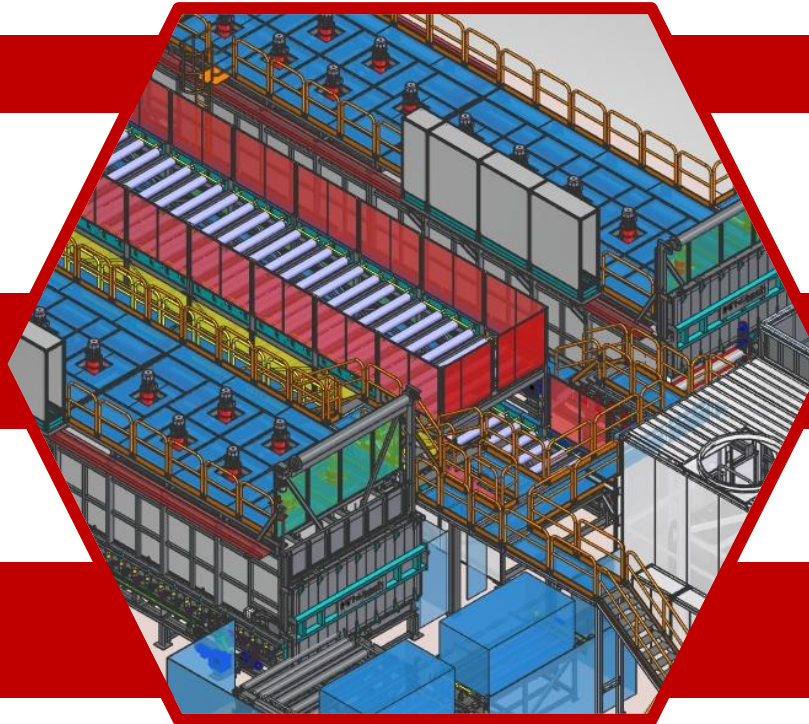

Maintenance and accessibility

Feasibility test in our plant

Availability within 24-48 hours

We serve the world

We supply plants for global markets; we follow all our customers and potential customers directly

Italian Market



Between our customers:

Berco Thyssenkrupp
Casartelli
Caterpillar
Feat
Faces
Fomas Group
Ghial
Mec-Track Caterpillar
Massucco
Siderforgerossi
Tecninox
Teksid Aluminum
TTN

European Market



Between our customers:

Aubert & Duval groupe Eramet
Erasteel
Eurings
Forges et Mécaniques de la Loire
Krenhof Austria
Nemak Poland
Safe Metals FWF
Starcam Czech Republic
Stellantis PSA

Global Market



Between our customers

Bharat Forge India
Fomas China
Frisa Forjados Mexico
Grant Prideco NOV groupe Mexico
Naledi Ring Rollers South Africa
Nemak Alabama
Nemak Monclova
RN Gupta India

Let's run the numbers

and the algorithms that make them work



Some numbers of our company

We are a company founded on people. Numbers are important, but they are only really important if they accompany and support the human value that sets us apart.

No. of internal team members	15
Average annual turnover	6 M€
Reached continents	4
Languages spoken by our team	4
Plants designed and started up in the last 10 years	39
Square meters for our offices	500
Square meters of construction building	4000
Square meters for outdoor space	5000
Square metres and power of the photovoltaic panels we have installed on our roof	4500 sqm for 1 MW

The algorithms that make us successful

Algorithms are logical tools for achieving effective solutions. But we do not stop at pure mathematics: we believe in the human value, intuition and experience that give numbers meaning. Some key words, which emerge from what our customers say about us, tell our true added value:

'lean, family-run business'

"total in-house know-how with mechanical, plant, electrical and software design in-house "

'always up to date with training on safety, general and specific heat treatment regulations'

"high responsiveness in problem solving, dynamism in production".

'ISO9001 and ISO 14001 certification as a commitment to environmental, sustainability and product quality policies'

"feasibility tests in the factory that offer the customer peace of mind".

'robust installations suitable for harsh environments'

'complete assembly at Hi-Tech headquarters before shipping. Unreserved presence of the site manager until production start-up and beyond'.

"research and development projects on software, strategic products and innovative energy".

'assistance always guaranteed anywhere in the world. Support with local companies we trust, already trained during assembly".

'commercial spare parts directly accessible on the market'

"socially responsible team. Company assessed with gold medal by Ecovadis'



Our technicians operate responsibly and transparently, aware that each system is the result of the synergetic work of a design and management team with proven experience and reliability.

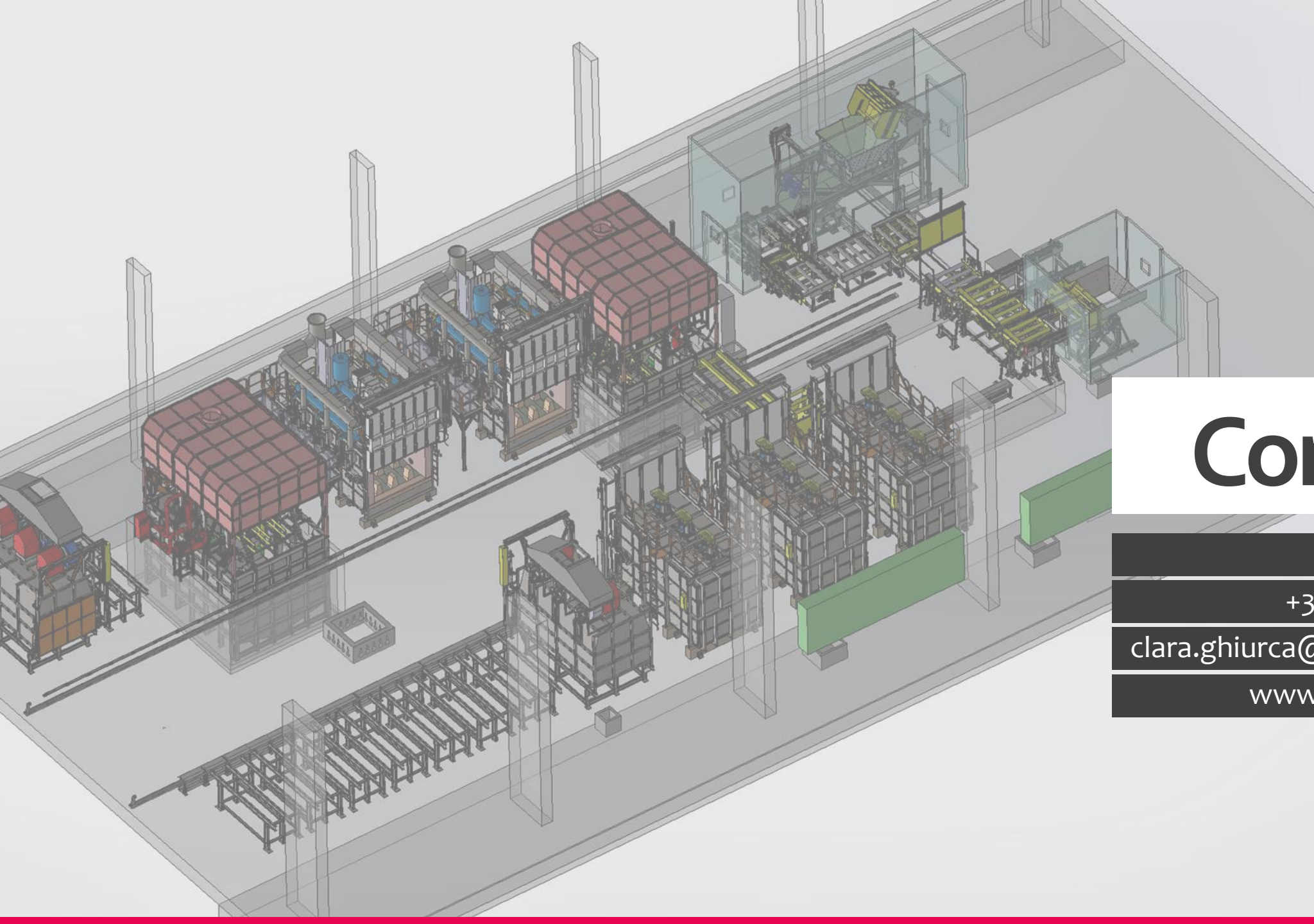

Contact us

Clara Ghiurca



+39 334 69 66 760



clara.ghiurca@hitecheng.com



www.hitecheng.com



