

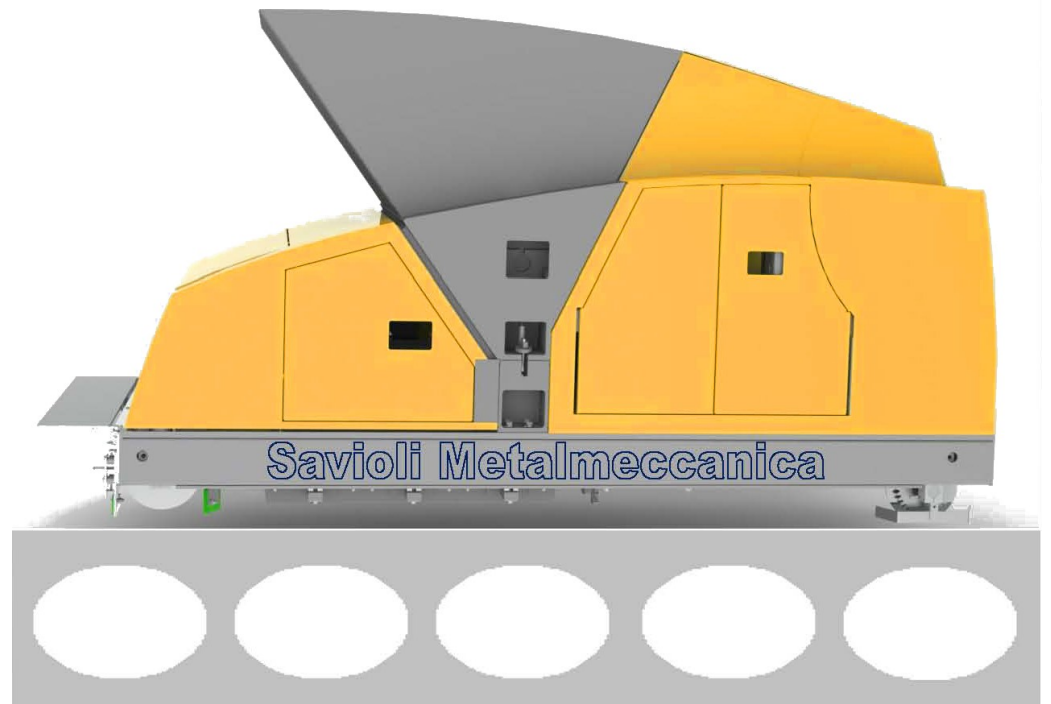

MASTER CATALOGUE



**Spare parts
for prestressed hollow-core slab extruders**

After twenty years of experience on repairing all types of extrusion plants, we now make and supply extruder spare and wear parts.

Advice	FLEXIBLE SOLUTION FOR ANY CONCRETE NEEDS
Technical support	
Sales service	
Overhauls	
Maintenance	

SPARE AND WEAR PARTS

ENGINEERING DEPARTMENT

Availability and courtesy are the basis of our working relationship with customers.

According to each single company 's needs, our engineering department studies, designs and draws each part to meet even the smallest requirement.

The department is always in close contact with the production to find and meet any customer's requirements. This is why the customer's satisfaction is for us an added and essential requisite in our overall view of quality.







FACTORY AND WAREHOUSE

Spreads over more than an indoor surface of 3700 m². Our company is composed of a factory where single parts are built and repaired, and a warehouse where we always have all parts in stock. Our flexible structure of production allows us to make smaller quantities opposed to the standard sizes. We are therefore more able to react properly and rapidly when orders are received, and thereby reducing waiting times.







EXTRUSION SCREW



TYPE	COD.	DESCRIPTION		EXTRUDER GROUP
H150	1510201R	EXTRUSION SCREW	RIGHT	8 VOIDS 
H150	1510201L	EXTRUSION SCREW	LEFT	
H200	2010201R	EXTRUSION SCREW	RIGHT	6 VOIDS 
H200	2010201L	EXTRUSION SCREW	LEFT	
H265/H300/H320	3010201R	EXTRUSION SCREW	RIGHT	5 VOIDS 
H265/H300/H320	3010201L	EXTRUSION SCREW	LEFT	
H320/H400/H500	5010201R	EXTRUSION SCREW	RIGHT	4 VOIDS 
H320/H400/H500	5010201L	EXTRUSION SCREW	LEFT	





HOLLOW-CORE SLEEVE



TYPE	COD.	DESCRIPTION		EXTRUDER GROUP
H150	TF.H150	HOLLOW-CORE SLEEVE	8 VOIDS	
H160	TF.H160	HOLLOW-CORE SLEEVE	6 VOIDS 	
H200	TF.H200	HOLLOW-CORE SLEEVE		5 VOIDS 
H265	TF.H265	HOLLOW-CORE SLEEVE		
H300	TF.H300	HOLLOW-CORE SLEEVE		
H320	TH.H320	HOLLOW-CORE SLEEVE	4 VOIDS 	
H360	TF.H360	HOLLOW-CORE SLEEVE		
H400	TF.H400	HOLLOW-CORE SLEEVE		
H440	TF.H440	HOLLOW-CORE SLEEVE		
H500	TF.H500	HOLLOW-CORE SLEEVE		

MASS GUIDE



TYPE	COD.	DESCRIPTION	EXTRUDER GROUP
H150	GMH150	MASS GUIDE	8 VOIDS 
H200	GMH200	MASS GUIDE	6 VOIDS 
H265	GMH265	MASS GUIDE	5 VOIDS 
H300	GMH300	MASS GUIDE	
H360	GMH360	MASS GUIDE	4 VOIDS 
H400	GMH400	MASS GUIDE	
H440	GMH440	MASS GUIDE	
H500	GMH500	MASS GUIDE	

GROUP: MODULE

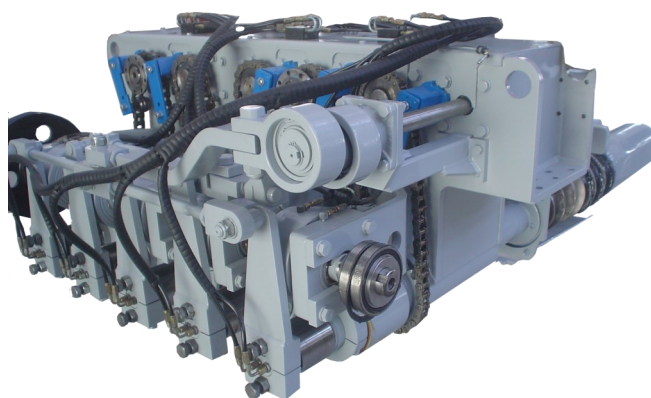

SUBGROUP: NOZZLE



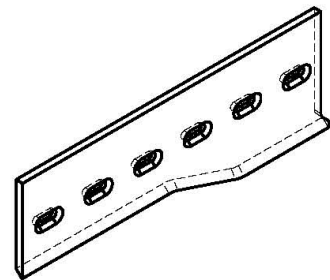
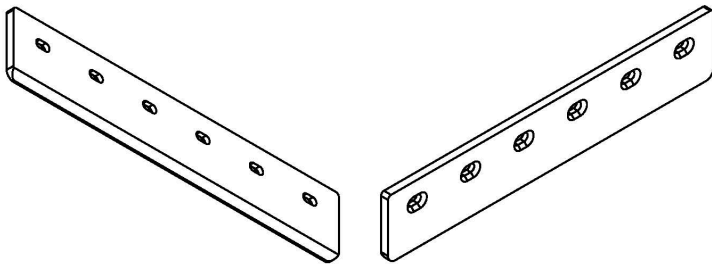
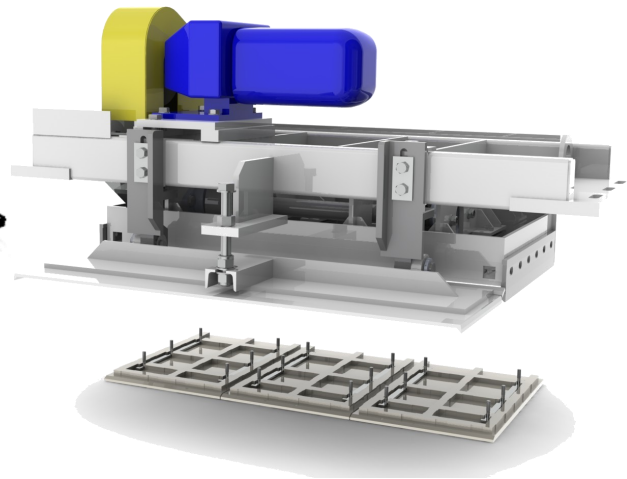
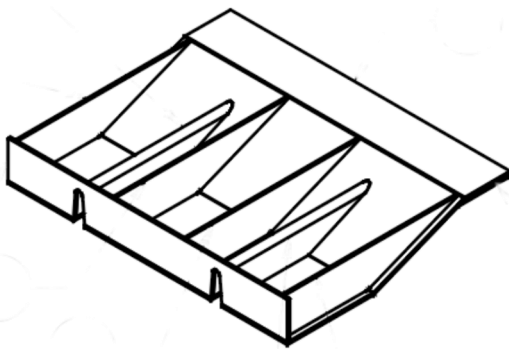
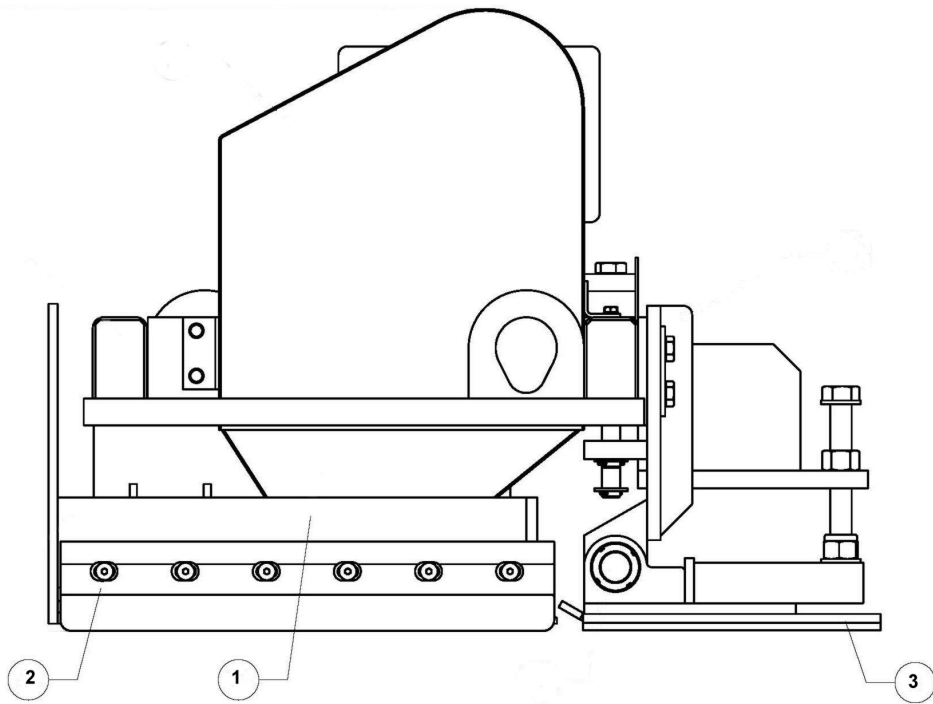

spare PARTS

SMOOTHING PLATE OF LEVELLING BEAM



POS.	TYPE	COD.	DESCRIPTION	EXTRUDER GROUP
1	H160	1603004	SMOOTING PLATE	6 VOIDS 
1	H200	2003017	SMOOTING PLATE	
1	H265	2003017	SMOOTING PLATE	5 VOIDS 
1	H300	3003017	SMOOTING PLATE	
1	H360	3603003	SMOOTING PLATE	4 VOIDS 
1	H400	4003003	SMOOTING PLATE	
1	H500	5003003	SMOOTING PLATE	

POS.	TYPE	COD.	DESCRIPTION	EXTRUDER GROUP
2	H160	16S03003RA	EDGE PART RIGHT	6 VOIDS 
2	H160	16S03003LA	EDGE PART LEFT	
2	H200	2003020A	EDGE PART	
2	H265	2003020A	EDGE PART	5 VOIDS 

POS.	TYPE	COD.	DESCRIPTION	EXTRUDER GROUP
3	H160	2003006	WEAR PLATE	6 VOIDS 
3	H200	2003006	WEAR PLATE	
3	H265	265.01.03.07-1	WEAR PLATE	5 VOIDS 
3	H300	300.01.03.07-1	WEAR PLATE	
3	H360	360.01.03.07-1	WEAR PLATE	4 VOIDS 
3	H400	400.01.03.07-1	WEAR PLATE	
3	H500	500.01.03.07-1	WEAR PLATE	





GROUP: MODULE

SUBGROUP: LEVELLING BEAM

spare PARTS

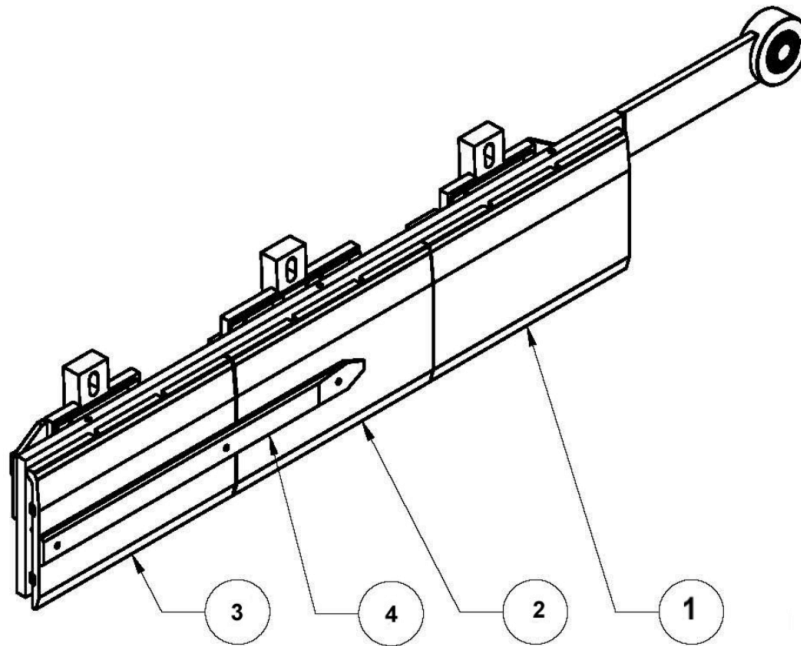
WEAR PLATE AND DOWEL BAR FOR SIDE PLATE ASSEMBLY



POS.	TYPE	COD.	DESCRIPTION		EXTRUDER GROUP
1	H200	2005007	PLATE	right	6 VOIDS 
2	H200	2005008	PLATE	central	
3	H200	2005009	PLATE	left	
4	H200	2005012	DOWEL BAR		
1	H265	2605006	PLATE	right	5 VOIDS 
2	H265	2605007	PLATE	central	
3	H265	2605008	PLATE	left	
4	H265	2005012	DOWEL BAR		
1-2	H300	3005006	PLATE	right+central	
3	H300	3005007	PLATE	left	
4	H300	3005012	DOWEL BAR		

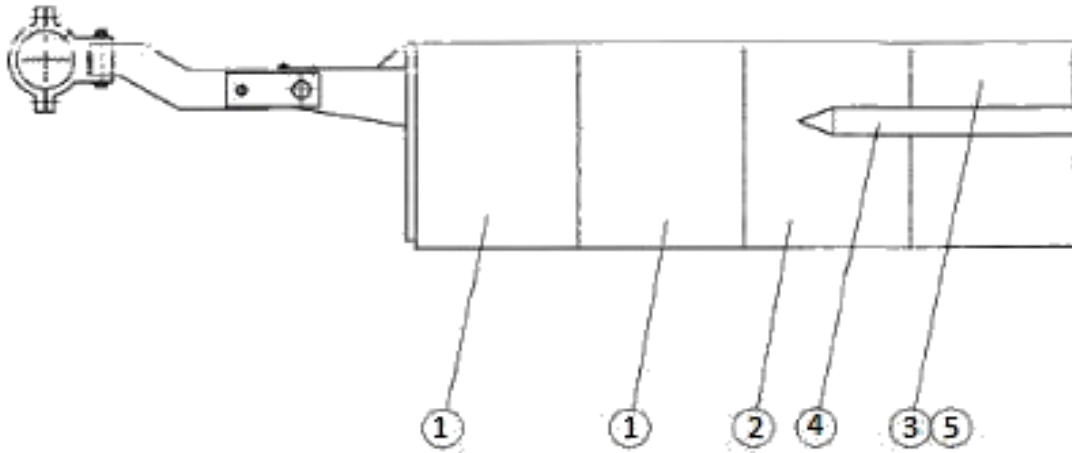

POS.	TYPE	COD.	DESCRIPTION		EXTRUDER GROUP
1	H360	3605006	PLATE	right 2Pc.	4 VOIDS 
2	H360	3605007	PLATE	central	
3-5	H360	3605009	PLATE	left	
4	H360	3205012	DOWEL BAR		
1	H400	4005006	PLATE	right 2 Pc.	
2	H400	4005007	PLATE	central	
3-5	H400	4005008	PLATE	left	
4	H400	3205012	DOWEL BAR		
1	H440	4405006	PLATE	Right 2 Pc.	
2	H440	4405007	PLATE	central	
3-5	H440	4405008 / 9	PLATE	left	
4	H440	4405012	DOWEL BAR 440		
1	H500	5005006	PLATE	right 2 Pc.	
2	H500	5005007	PLATE	central	
3-5	H500	5005008	PLATE	left	
4	H500	5005012	DOWEL BAR		

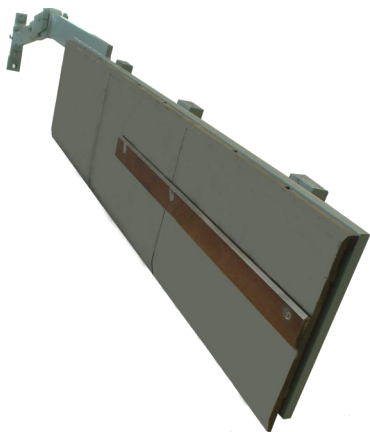





GROUP: MODULE

SUBGROUP: SIDE PLATE

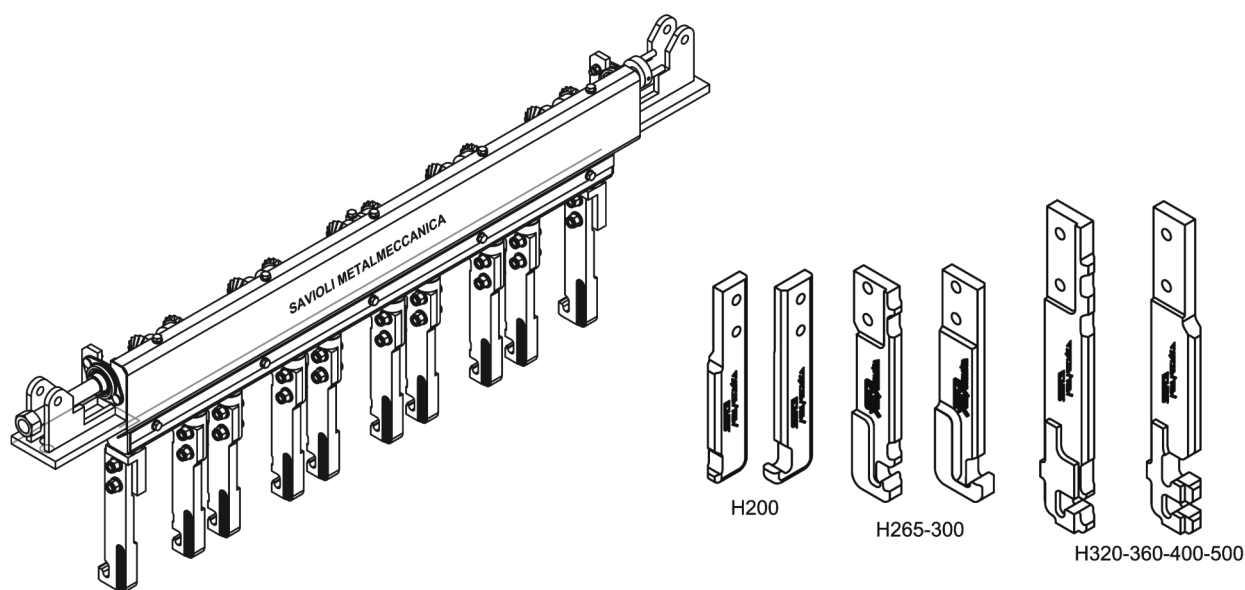
spare PARTS

STRAND GUIDES



TYPE	COD.	DESCRIPTION	EXTRUDER GROUP
H150	1504004	INNER	8 VOIDS 
H150	1504005	OUTER	
H200	2004011	INNER	6 VOIDS 
H200	2004012	OUTER	
H265	2604013	INNER = OUTER	5 VOIDS 
H300	2604013	INNER = OUTER	
H320**/360/400	3204004	INNER	4 VOIDS 
H320**/360/400	3204005	OUTER	
H320**/360/400	3604006	OUTER 2 STRANDS	
H440	4404007	INNER	
H440	4404008	OUTER 2 STRANDS	
H500	5004004	INNER	
H500	5004006	OUTER 2 STRANDS	

** possibility for 5 holes extruder

GROUP: MODULE

SUBGROUP: STRAND GUIDE



DAMPERS

SIDE PLATES

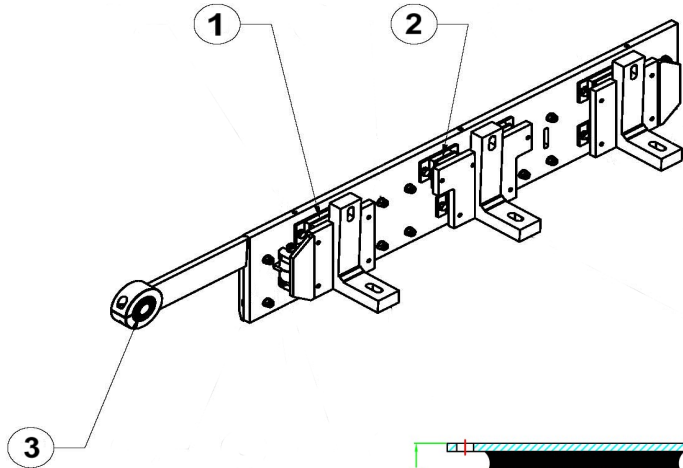

POS.	COD.	L 1	L 2	H
1	060001	168	57	42
2	060004	108	57	42

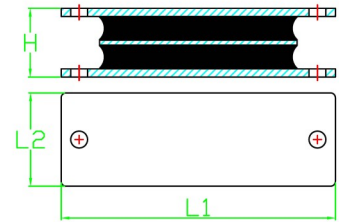

POS.	COD.	L	D	d
3	060009	48	65	30

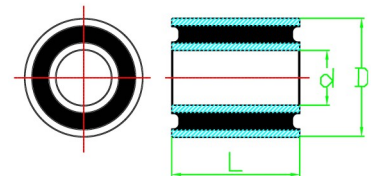

LEVELLING BEAM

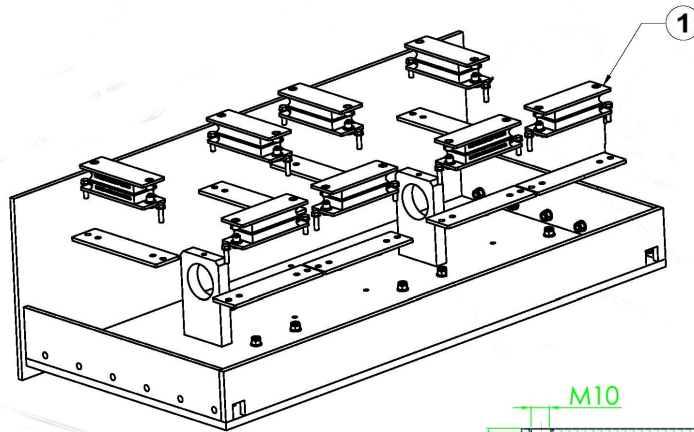

POS.	COD.	L 1	L 2	H	M10
1	060005	168	57	48	

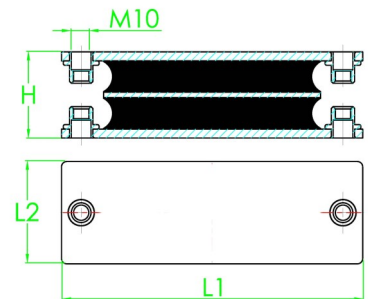



SAVIOLI METALMECCANICA S.r.l.

- Headquarters:
Via R.Gemma, 13
46035 - OSTIGLIA (MANTOVA) ITALY
- Production plant and goods destinationi:
Via Canove,44 Z.A.Roncanova
37060 - GAZZO VERONESE (VERONA) ITALY

Tel. (+39)0442-550345

E-mail: info@saviolimetalmecanica.it

VAT CODE : IT02048070201

**Spare parts
for prestressed hollow-core slab extruders**