

speedy

FRENUM

CERNIERA IDRAULICA
HYDRAULIC PATCH
BISAGRA HIDRAULICA

I love Einstein and I lived my life by some of his quotes

"Try not to become a man of success, but rather try to become a man of value".

For a while now in my little spare time, my dedication to my business and its evolution, made me ponder on a few revolutionary concepts to make life better and easier for everyone.

one of my ideas was to create a "HYDRAULIC" HINGE WHICH COULD BE USED TO REPLACE ALL OF THE STANDARD BOTTOM FITTINGS hinges FOR ALL GLASS DOORS with the same standard cut out.

Well, that idea did not leave my mind, I kept hearing more of Einstein's words "Success comes from curiosity, concentration, perseverance and self criticism."

So I persevered and started simplifying something that on the surface appeared complicated and impossible. It is with great "humble" pride that I present to you my dream realised: FRENUM

Milenco Marinoni - CEO



Speedy è sinonimo di chiudiporta dal 1942.

Speedy, completamente progettati e costruiti in Italia con componenti e materiali di prima qualità, sono fabbricati utilizzando sofisticate metodologie di produzione e controllo. Ciò permette di ridurre al minimo gli attriti tra i componenti interni, in modo da garantire un elevato rendimento (rapporto tra coppia applicata e coppia restituita) ed un'impareggiabile durata.

Speedy, particolarmente silenziosi e specificatamente progettati per porte vetrate, sono utilizzabili anche per porte in legno ed in metallo. Soddisfano inoltre qualsiasi altra esigenza d'installazione con la caratteristica, comune a tutti i prodotti SbyC, della costante focalizzazione sulla qualità, sulla facilità di installazione, sul disegno originale e sull'innovazione.

Speedy sono continuamente testati secondo le norme EN1154 su apposito centro computerizzato. La normale produzione Speedy viene anche testata al 100% per garantirne il perfetto funzionamento e l'assenza di perdite d'olio con particolare attenzione al collaudo della valvola di sicurezza, da sempre caratteristica Speedy, che serve per prevenire rotture involontarie delle cerniere o del chiudiporta.



Speedy has been synonymous with door closers since 1942.

Speedy, are completely designed and manufactured in Italy with high quality materials and components. They are manufactured using sophisticated methods of production and quality control. This allows us to reduce to the minimum the friction between all the internal components, in order to ensure "high efficiency" (ratio between the opening and the closing torques) as well as an incomparable durability.

Speedy, specifically designed for glass doors, are particularly silent and suitable for any timber and metal doors. They can meet any installation requirement thanks to the features common to all SbyC products: constant focus on quality, ease of installation, original design, and innovation.

Speedy are constantly checked in accordance with EN1154 standards on a special computerized center. They are also 100% tested to ensure perfect functioning with no oil leakages. During this test we also check the safety valve, a well known Speedy characteristic, which prevents involuntary breakage of the hinges or door closer.



Speedy es sinónimo de cierrapuertas desde 1942.

Speedy, completamente diseñados y contruidos en Italia con componentes y materiales de primera calidad, están fabricados utilizando sofisticadas metodologías de producción y control. Esto permite reducir al mínimo los desgastes entre los componentes internos, de manera que se garantiza un elevado rendimiento de los mismos y una duración incomparable.

Speedy, particularmente silenciosos, diseñados específicamente para puertas de vidrio, también se pueden utilizar en puertas de madera y metálicas. Están preparados para satisfacer cualquier otra exigencia en una instalación con la característica, común a todos los productos SbyC, de la constante focalización en la calidad, facilidad de instalación, original diseño y la innovación.

Speedy están continuamente testados según las normas EN1154 en un centro de pruebas computerizado. Además en el propio sistema de producción y montaje de los Speedy éstos se prueban al 100% para garantizar su perfecto funcionamiento y la ausencia de pérdidas de aceite. En este proceso es donde se testa la válvula de seguridad, una pieza característica de los Speedy, que sirve para prevenir roturas involuntarias de los pernios o del cierrapuertas.



La nuova cerniera idraulica Speedy per le porte interne in vetro.

La prima cerniera al mondo che può trasformare una porta in vetro senza chiudiporta in una con chiusura controllata idraulicamente, mantenendo il design originale della porta e cambiando solamente la cerniera inferiore e il punto di rotazione a terra.

Un chiudiporta Speedy EN2 a tutti gli effetti, completamente realizzato in Italia, per porte fino a 100kg.

Ha le stesse dimensioni e lavorazioni del vetro delle cerniere superiori ed inferiori standard (165mm x 50mm).

Può essere usata al posto di una cerniera inferiore standard con tutti gli accessori della serie 40000 in tutte le finiture disponibili.

Facile da installare. Sono necessari solo 10min come per una porta standard senza chiudiporta.

L'ingegnosa piastrina di fissaggio a terra consente l'installazione anche su pavimenti particolarmente sconnessi o pendenti senza nessun problema.

Il punto di rotazione inferiore è costituito da un'apposita piastrina regolabile ed anche la velocità di chiusura è regolabile per consentire qualsiasi installazione.

Una sola valvola permette la regolazione della velocità di chiusura.

Come tutti i chiudiporta Speedy, possiede le funzioni Easy Opening e la valvola di sicurezza.

Testata secondo le norme europee EN 1154.



The New Speedy Hydraulic Hinge for Interior Applications.

The world's first hydraulic patch fitting that can turn an already installed free swinging glass door into a fully controlled one, without affecting the original design. Meaning the only change will be to the bottom pivot and the bottom patch.

It is a true Speedy EN2 door closer, completely manufactured in Italy, suitable for doors up to 100kg.

It has the exact same dimensions as the standard top and bottom patches (165mm x 50mm) and utilizes the same cut out.

It can be used instead of a standard bottom patch for double acting doors. It can be used together with all other patch fittings (40000 series) in any of their finishes.

Easy to install, it takes less than 10 minutes like any standard free-swinging glass door.

The smart floor fixing plate allows the Frenum installation onto sloped and unregular flooring levels.

Adjustable bottom pivot and closing speed to suit any installation requirement.

Only one valve controls the closing speed.

As with all Speedy floor springs it has the Easy Opening and the Safety Valve functions.

Tested in accordance with EN1154.



La nueva bisagra hidráulica para aplicaciones interiores .

Es la primera en el mundo que permite de transformar una puerta con pivote loco en una puerta controlada sin afectar el diseño original de la puerta, simplemente cambiando la bisagra baja y su punto de giro.

Es un auténtico cierrapuertas Speedy EN2, completamente construido en Italia, para puertas hasta 100kg.

Tiene exactamente las mismas dimensiones y muescas en los vidrios que las bisagras estándar (165mm x 50mm).

Se puede usar en lugar de una bisagra inferior vaivén estándar. Se puede usar con todas las demás bisagras de la gama 40000 en cualquiera de sus acabados.

Instalación sencilla: se instala en menos de 10 minutos igual que instalar un herraje bajo o una puerta estándar.

La ingeniosa pletina de fijación a suelo permite la instalación incluso en suelos irregulares y con desniveles.

Punto de giro inferior y velocidad de cierre ajustable para adaptarse a cualquier requisito de instalación.

Una sola válvula controla la velocidad de cierre.

Como todos los cierrapuertas Speedy tiene las funciones "Easy Opening" y la válvula de seguridad.

Testada según las normas EN1154



DATI TECNICI

Technical Data / Datos Técnicos

<p>✓ LARGHEZZA MASSIMA PORTA MAXIMUM DOOR WIDTH ANCHO MÁXIMO DE LA PUERTA</p>	<p>Forza Gialla Yellow Strength Fuerza Amarilla</p>	<p>90 cm</p>
<p>✓ PESO DELLA PORTA SOSTENIBILE DOORS WEIGHT UP TO PESO DE LA PUERTA SOSTENIBILE</p>	<p>100 Kg</p>	
<p>✓ PESO DELLA CONFEZIONE WEIGHT OF PACKAGE PESO DE LA CONFECCIÓN</p>	<p>1.0 Kg</p>	

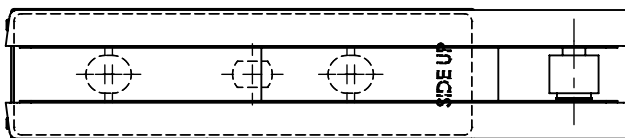
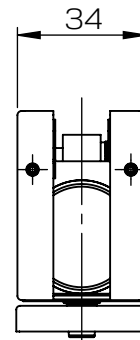
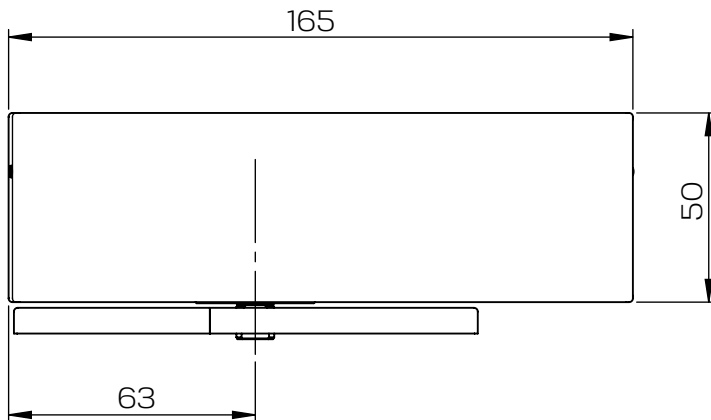

● FERMO
hold-open
Retenció

● LIMITE OPERATIVO
Working Limit
Limite Funcional

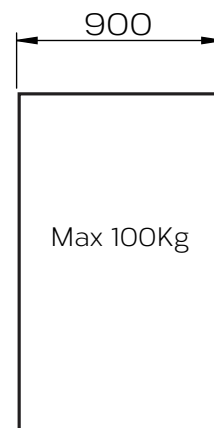
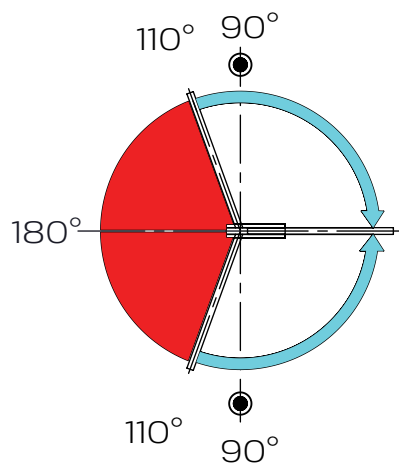

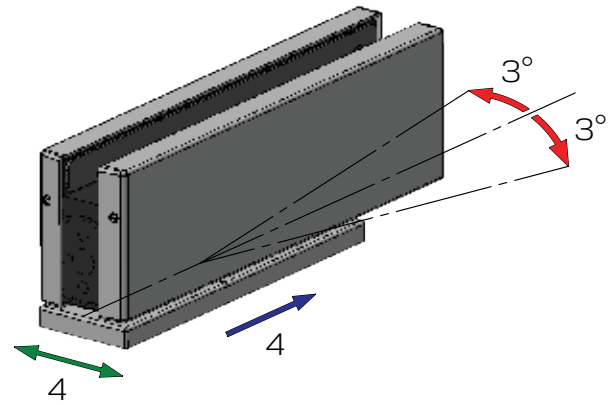
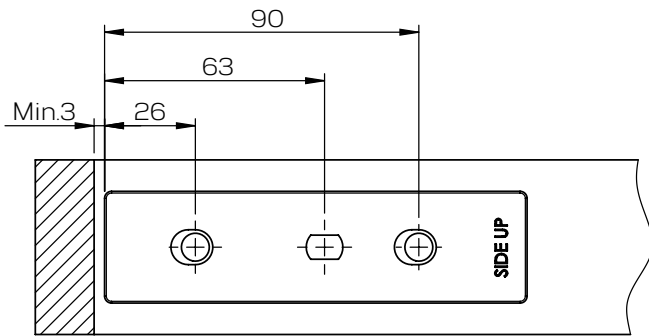
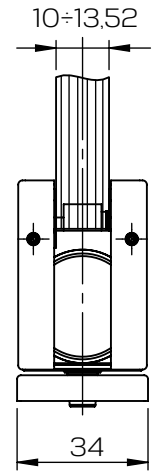
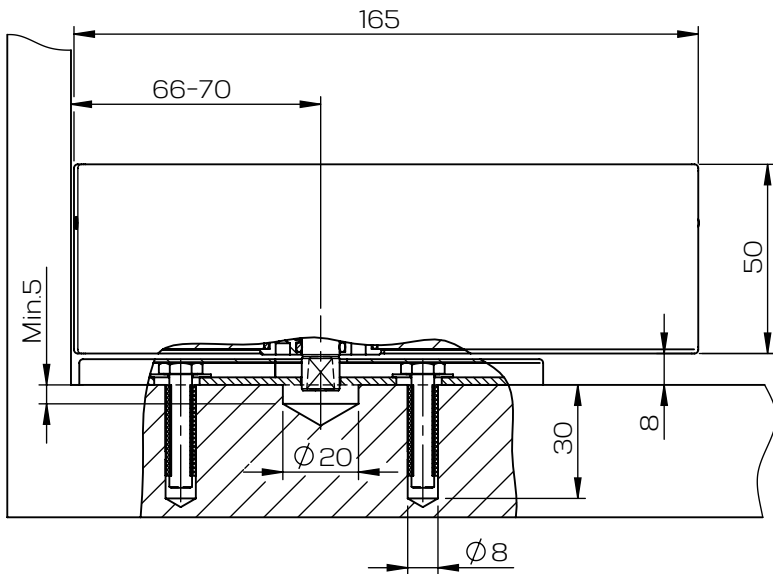

T4.01

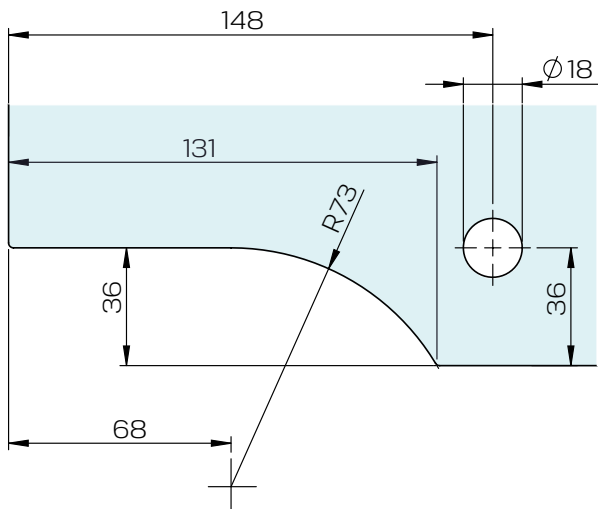

FINITURE STANDARD

Standard finishes/Acabados estándar

Alluminio/Aluminium/Aluminio

Acciaio Inox Satinato/
Satin Stainless Steel/Acero Inoxidable Satinado

Acciaio Inox Lucido/
Polished Stainless Steel/Acero Inoxidable Pulido





SPEEDYBYCASMA SRL

VIA I MAGGIO, 86 - 20013 MAGENTA (MI) - ITALY
PH. +39 02 97298418 - FAX +39 02 97299006
WWW.SBYC.IT - INFO@SBYC.IT