

TMT  [®]
Tanks & Trailers

Una storia lunga 50 anni

TMT Tanks & Trailers basa la sua produzione su tre valori fondamentali: Prodotto, Persone, Passione.

Da questo fondamento nasce la determinazione di creare prodotti senza rivali, tramite la ricerca di materiali di alta qualità, elevati controlli di sicurezza, eccellente e accurata lavorazione per dare ai nostri Clienti il massimo del profitto.

Le nostre linee di prodotto sono:

- Semirimorchi Walking Floor®
- Autobotti
- Container Walking Floor®
- Portacontainer
- Impianti di misurazione e pompaggio petrolifero
- Impianto di trasferimento rifiuti

Il nostro motto? *TMT... Tanks & Trailers Creators.*
Creiamo da zero il prodotto che il cliente desidera!

A story 50 years long

TMT Tanks & Trailers bases its production on three fundamental values: Product, People, Passion.

From this foundation comes the determination to create unrivaled products, through the search for high quality materials, high security controls, excellent and accurate workmanship to give our Customers maximum profit.

Our product lines are:

- Walking Floor® semitrailers
- Tanks
- Containers Walking Floor®
- Container chassis
- Oil measuring and pumping plants
- Waste transfer system

Our motto? *TMT... Tanks & Trailers Creators.*
We create the product the customer wants from scratch!



Une histoire de 50 ans

TMT Tanks & Trailers base sa production sur trois valeurs fondamentales
Produit, Personnes, Passion.

C'est sur cette base qu'est née la détermination de créer des produits sans égal, à travers la recherche de matériaux de haute qualité, de contrôles de sécurité élevés, d'un travail excellent et soigné pour donner à nos Clients le maximum de profit.

Nos gammes de produits sont:

- Semi-remorques Walking Floor®
- Camions-citernes
- Containers Walking Floor®
- Porte-containers
- Stations de mesure et de pompage de pétrole
- Installation de transfert de déchets

Notre devise? *TMT... Tanks & Trailers Creators.*

Nous créons à partir de zéro le produit souhaité par le client!

50 Jahre zu Diensten unserer Kunden

TMT Tanks & Trailers gründet seine Produktion auf drei grundlegende Werte:
Produkt, Personen, Leidenschaft.

Auf dieser Grundlage entsteht der starke Wille unvergleichliche Produkte herzustellen, mit Hilfe der Suche nach Materialien höchster Qualität, hoher Sicherheitsstandards, außerordentlicher und genauster Verarbeitung, um unseren Kunden den größten Profit zu ermöglichen.

Unsere Produktlinien sind:

- Schubboden Walking Floor®
- Tankwagen
- Container Walking Floor®
- Containerträger
- Mess- und Pumpanlagen für Erdöl
- Abfalltransportanlage

Unser Motto? *TMT... Tanks & Trailers Creators.*

Wir bauen das Produkt, das der Kunde möchte, von Grund auf neu!



I nostri prodotti: vasta gamma

Diversi prodotti per diversi utilizzi, per garantire la massima flessibilità, qualità, affidabilità ed efficienza.

Conchiglia WF Standard.....	4
Conchiglia WF porte laterali 3.4.....	6
Conchiglia WF porte laterali 6.3.....	8
Conchiglia WF porte lat. 6.3+6.3..	10
Scrigno WF	12
Conchiglia Frigo WF.....	14
Leakproof.....	16
Intermodale WF	18
Container WF.....	20
Profili	22
Optionals	23
Portacontainer	26
Cisterna Rifiuti.....	28
Cisterna Carburanti	29
Tanks.....	30
Impianti e servizi	32
Certificazioni e riconoscimenti	34

Our products: wide range

Different products for different uses, to ensure maximum flexibility, quality, reliability and efficiency.

Conchiglia WF Standard.....	4
Conchiglia WF side doors 3.4	6
Conchiglia WF side doors 6.3	8
Conchiglia WF side doors 6.3+6.3	10
Scrigno WF	12
Conchiglia Refrigerator WF	14
Leakproof.....	16
Intermodale WF	18
Container WF.....	20
Profiles	22
Optionals	23
Container Chassis	26
Waste Tank.....	28
Fuel Tank	29
Tanks.....	30
Plants and services	32
Certifications and Recognitions.....	34

Nos produits: large gamme

Différents produits pour différentes utilisations, pour garantir la flexibilité, qualité, fiabilité et efficacité maximales.

Unsere Produkte: Große Auswahl

Unterschiedliche Produkte für unterschiedliche Verwendungszwecke, um maximale Flexibilität, Qualität, Zuverlässigkeit und Effizienz zu gewährleisten.





Conchiglia WF Standard

Semirimorchi / Walking floor

___ **Utilizzo:** ✓ Rifiuti ✓ Raccolta e conferimento CDR ✓ Plastica ✓ Carta (sia sfusi che imballati) ✓ Umido ✓ Indifferenziata ✓ Agricolo ✓ Forestale ✓ Riciclaggio ✓ Segatura ✓ Cippato ✓ Cereali ✓ Big Bag ✓ Fieno ✓ Foraggi ✓ Tuberi ✓ 33 europallet

___ **Use:** ✓ Waste ✓ Collection and transfer RDF ✓ Plastic ✓ Paper (both loose and packed) ✓ Wet ✓ Undifferentiated ✓ Agricultural ✓ Forestry ✓ Recycling ✓ Sawdust ✓ Woodchips ✓ Cereals ✓ Big Bag ✓ Hay ✓ Forages ✓ Tubers ✓ 33 europallets

___ **Utilisation:** ✓ Déchets ✓ Collecte et livraison des CDD ✓ Plastique ✓ Papier (en vrac et emballés) ✓ Humide ✓ Non différencié ✓ Agricole ✓ Forestier ✓ Recyclage ✓ Sciure ✓ Copeaux de bois ✓ Céréales ✓ Big Bag ✓ Foin ✓ Fourrage ✓ Tubercules ✓ 33 europallettes

___ **Gebrauch:** ✓ Abfälle ✓ Sammlung und Übertragung KAA ✓ Plastik ✓ Papier (unverpackt oder verschnürt) ✓ Biomüll ✓ Restmüll ✓ landwirtschaftlicher Abfall ✓ Waldabfälle ✓ Recycling ✓ Sägespäne ✓ Hackschnitzel ✓ Korn ✓ Big Bag ✓ Heu ✓ Grünfutter ✓ Knollenfrüchte ✓ 33 Europaletten



Conchiglia E00

Weight (kg)	7300
Chassis and load-bearing structure	Self-supporting steel chassis with aluminium box bolted to the frame
Total weight (kg)	40000 / 45000
Suspensions	Air suspensions HALDEX, WABCO / tridem SAF, ROR, JOST, BPW
Moving floor system	Cargo Floor® System or Keith Walking Floor®
Floor	21 or 24 alu profiles 6-8-10 mm
Walls	30 mm aluminium extruded profiles

Conchiglia E60

Weight (kg)	7400
Chassis and load-bearing structure	Continuous steel chassis, aluminium box bolted to the frame
Total weight (kg)	40000 / 45000
Suspensions	Air suspensions HALDEX, WABCO / tridem SAF, ROR, JOST, BPW
Moving floor system	Cargo Floor® System or Keith Walking Floor®
Floor	21 or 24 alu profiles 6-8-10 mm
Walls	30 mm aluminium extruded profiles



Conchiglia WF porte laterali 3.4

Semirimorchi / Walking floor

___ **Utilizzo:** ✓ Rifiuti ✓ Raccolta e conferimento CDR ✓ Plastica ✓ Carta (sia sfusi che imballati) ✓ Umido ✓ Indifferenziata ✓ Agricolo ✓ Forestale ✓ Riciclaggio ✓ Segatura ✓ Cippato ✓ Cereali- Big Bag ✓ Fieno ✓ Foraggi ✓ Tuberi ✓ Carico e Scarico Colli ✓ Corpi Indivisibili ✓ Pallet ✓ Cassoni ✓ Pannelli ✓ Profilati ✓ 33 europallet

___ **Use:** ✓ Waste ✓ Collection and transfer RDF ✓ Plastic ✓ Paper (both loose and packed) ✓ Wet ✓ Undifferentiated ✓ Agricultural ✓ Forestry ✓ Recycling ✓ Sawdust ✓ Woodchips ✓ Cereals ✓ Big Bag ✓ Hay ✓ Fodder ✓ Tubers ✓ Loading and Unloading Packages ✓ Bodies Indivisible ✓ Pallets ✓ Boxes ✓ Panels ✓ Profiles ✓ 33 europallets

___ **Utilisation:** ✓ Déchets ✓ Collecte et livraison des CDD ✓ Plastique ✓ Papier (en vrac et emballés) ✓ Humide ✓ Non différencié ✓ Agricole ✓ Forestier ✓ Recyclage ✓ Sciure ✓ Copeaux de bois ✓ Céréales ✓ Big Bag ✓ Foin ✓ Fourrage ✓ Tubercules- Chargement et déchargement de colis ✓ Corps indivisibles ✓ Palettes ✓ Caissons ✓ Panneaux ✓ Profilés ✓ 33 europalettes

___ **Gebrauch:** ✓ Abfälle ✓ Sammlung und Übertragung KAA ✓ Plastik ✓ Papier (unverpackt und verschnürt) ✓ Biomüll ✓ Restmüll ✓ landwirtschaftlicher Abfall ✓ Waldabfälle ✓ Recycling ✓ Sägespäne ✓ Hackschnitzel ✓ Korn ✓ Big Bag ✓ Heu ✓ Grünfutter ✓ Knollenfrüchte ✓ Laden- und Entladen von Packstücken ✓ unteilbare Gegenstände ✓ Paletten ✓ Kasten ✓ Platten ✓ Profile ✓ 33 Europaletten

Conchiglia E00

Weight (kg)	7500
Chassis and load-bearing structure	Self-supporting steel chassis with aluminium box bolted to the frame
Total weight (kg)	40000 / 45000
Suspensions	Air suspensions with HALDEX, WABCO tridem SAF, ROR, JOST, BPW
Moving floor system	Cargo Floor® System or Keith Walking Floor®
Floor	21 or 24 alu profiles 6-8-10 mm
Walls	30 mm aluminium extruded profiles

Conchiglia E60

Weight (kg)	7500
Chassis and load-bearing structure	Continuous steel chassis, aluminium box bolted to the frame
Total weight (kg)	40000 / 45000
Suspensions	Air suspensions with HALDEX, WABCO tridem SAF, ROR, JOST, BPW
Moving floor system	Cargo Floor® System or Keith Walking Floor®
Floor	21 or 24 alu profiles 6-8-10 mm
Walls	30 mm aluminium extruded profiles

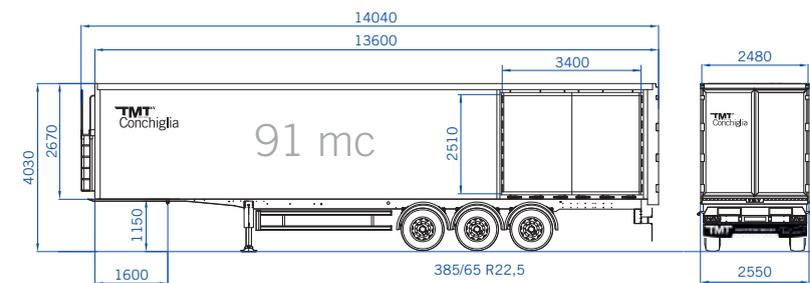
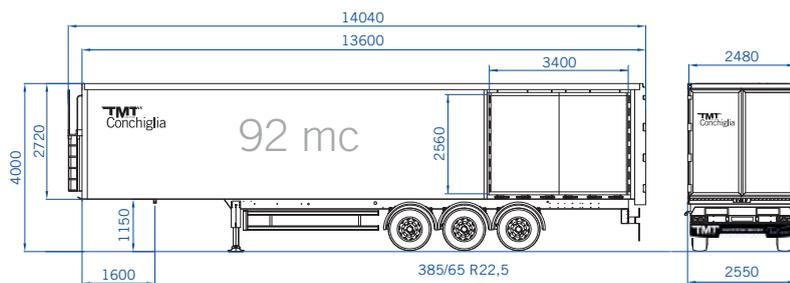

Conchiglia WF porte laterali 6.3

Semirimorchi / Walking floor

___ **Utilizzo:** ✓ Rifiuti ✓ Raccolta e conferimento CDR ✓ Plastica ✓ Carta (sia sfusi che imballati) ✓ Umido ✓ Indifferenziata ✓ Agricolo ✓ Forestale ✓ Riciclaggio ✓ Segatura ✓ Cippato ✓ Cereali- Big Bag ✓ Fieno ✓ Foraggi ✓ Tuberi ✓ 33 europallet

___ **Use:** ✓ Waste ✓ Collection and transfer RDF ✓ Plastic ✓ Paper (both loose and packed) ✓ Wet ✓ Undifferentiated ✓ Agricultural ✓ Forestry ✓ Recycling ✓ Sawdust ✓ Woodchips ✓ Cereals ✓ Big Bag ✓ Hay ✓ Forages ✓ Tubers ✓ 33 europallets

___ **Utilisation:** ✓ Déchets ✓ Collecte et livraison des CDD ✓ Plastique ✓ Papier (en vrac et emballés) ✓ Humide ✓ Non différencié ✓ Agricole ✓ Forestier ✓ Recyclage ✓ Sciure ✓ Copeaux de bois ✓ Céréales ✓ Big Bag ✓ Foin ✓ Fourrage ✓ Tubercules ✓ 33 europalletes

___ **Gebrauch:** ✓ Abfälle ✓ Sammlung und Übertragung KAA ✓ Plastik ✓ Papier (unverpackt oder verschnürt) ✓ Biomüll ✓ Restmüll ✓ landwirtschaftlicher Abfall ✓ Waldabfälle ✓ Recycling ✓ Sägespäne ✓ Hackschnitzel ✓ Korn ✓ Big Bag ✓ Heu ✓ Grünfutter ✓ Knollenfrüchte ✓ 33 Europaletten

Conchiglia E00

Weight (kg)	7500
Chassis and load-bearing structure	Self-supporting steel chassis with aluminium box bolted to the frame
Total weight (kg)	40000 / 45000
Suspensions	Air suspensions HALDEX, WABCO / tridem SAF, ROR, JOST, BPW
Moving floor system	Cargo Floor® System or Keith Walking Floor®
Floor	21 or 24 alu profiles 6-8-10 mm
Walls	30 mm aluminium extruded profiles

Conchiglia E60

Weight (kg)	7600
Chassis and load-bearing structure	Continuous steel chassis, aluminium box bolted to the frame
Total weight (kg)	40000 / 45000
Suspensions	Air suspensions HALDEX, WABCO / tridem SAF, ROR, JOST, BPW
Moving floor system	Cargo Floor® System or Keith Walking Floor®
Floor	21 or 24 alu profiles 6-8-10 mm
Walls	30 mm aluminium extruded profiles

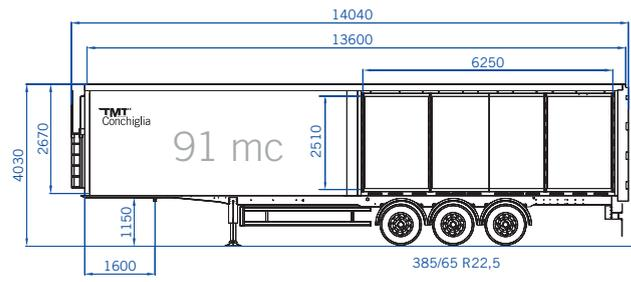
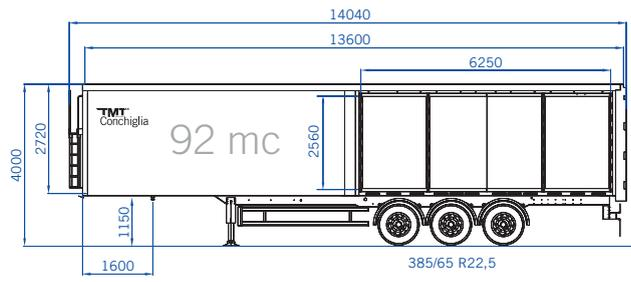

Conchiglia WF porte laterali 6.3+6.3

Semirimorchi / Walking floor

___ **Utilizzo:** ✓ Rifiuti ✓ Raccolta e conferimento CDR ✓ Plastica ✓ Carta (sia sfusi che imballati) ✓ Umido ✓ Indifferenziata ✓ Agricolo ✓ Forestale ✓ Riciclaggio ✓ Segatura ✓ Cippato ✓ Cereali- Big Bag ✓ Fieno ✓ Foraggi ✓ Tuberi ✓ 33 europallet

___ **Use:** ✓ Waste ✓ Collection and transfer RDF ✓ Plastic ✓ Paper (both loose and packed) ✓ Wet ✓ Undifferentiated ✓ Agricultural ✓ Forestry ✓ Recycling ✓ Sawdust ✓ Woodchips ✓ Cereals ✓ Big Bag ✓ Hay ✓ Forages ✓ Tubers ✓ 33 europallets

___ **Utilisation:** ✓ Déchets ✓ Collecte et livraison des CDD ✓ Plastique ✓ Papier (en vrac et emballés) ✓ Humide ✓ Non différencié ✓ Agricole ✓ Forestier ✓ Recyclage ✓ Sciure ✓ Copeaux de bois ✓ Céréales ✓ Big Bag ✓ Foin ✓ Fourrage ✓ Tubercules ✓ 33 europallettes

___ **Gebrauch:** ✓ Abfälle ✓ Sammlung und Übertragung KAA ✓ Plastik ✓ Papier (unverpackt oder verschnürt) ✓ Biomüll ✓ Restmüll ✓ landwirtschaftlicher Abfall ✓ Waldabfälle ✓ Recycling ✓ Sägespäne ✓ Hackschnitzel ✓ Korn ✓ Big Bag ✓ Heu ✓ Grünfutter ✓ Knollenfrüchte ✓ 33 Europaletten

Conchiglia E60 Light

Weight (kg)	8100
Chassis and load-bearing structure	Continuous steel chassis, aluminium box bolted to the frame
Total weight (kg)	40000 / 45000
Suspensions	Air suspensions with HALDEX, WABCO tridem SAF, ROR, JOST, BPW
Moving floor system	Cargo Floor® System or Keith Walking Floor®
Floor	21 or 24 alu profiles 6-8-10 mm
Walls	30 mm aluminium extruded profiles

Conchiglia E110 Heavy

Weight (kg)	8700
Chassis and load-bearing structure	Continuous steel chassis, aluminium box bolted to the frame
Total weight (kg)	40000 / 45000
Suspensions	Air suspensions with HALDEX, WABCO tridem SAF, ROR, JOST, BPW
Moving floor system	Cargo Floor® System or Keith Walking Floor®
Floor	21 or 24 alu profiles 6-8-10 mm
Walls	30 mm aluminium extruded profiles



Light



Heavy

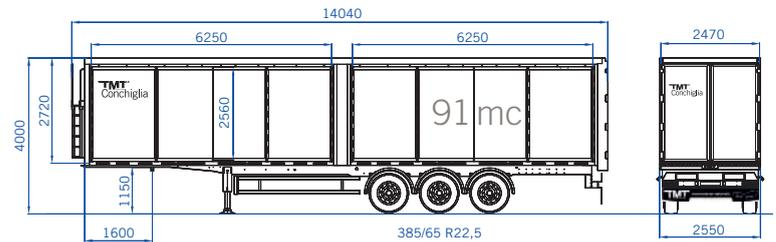
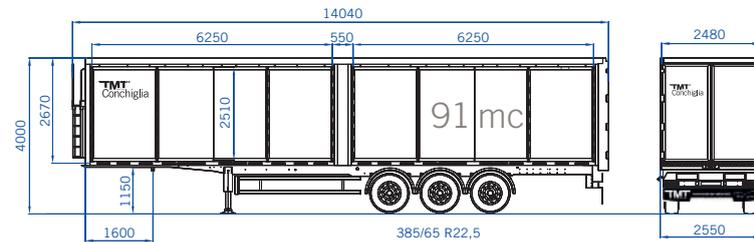
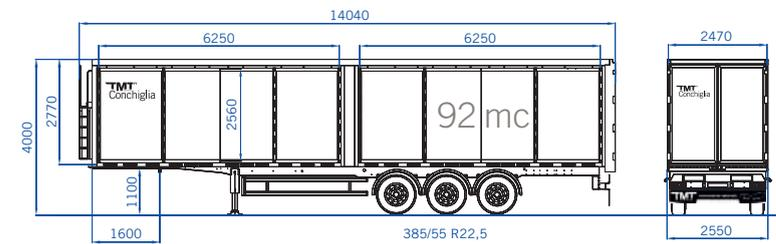
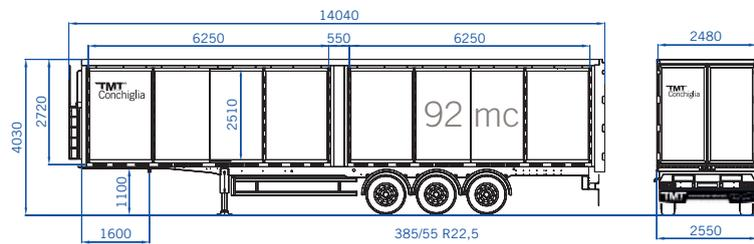

Light

Heavy



Scigno WF

Semirimorchi / Walking floor

___ **Utilizzo:** ✓ Rifiuti ✓ Raccolta e conferimento CDR ✓ Plastica ✓ Carta (sia sfusi che imballati) ✓ Umido ✓ Indifferenziata ✓ Agricolo ✓ Forestale ✓ Riciclaggio ✓ Segatura ✓ Cippato ✓ Cereali ✓ Big Bag ✓ Fieno ✓ Foraggi ✓ Tuberi ✓ Carico e Scarico Colli ✓ Corpi Indivisibili ✓ Pallet ✓ Cassoni ✓ Pannelli ✓ Profilati ✓ 33 europallet

___ **Use:** ✓ Waste ✓ Collection and transfer RDF ✓ Plastic ✓ Paper (both loose and packed) ✓ Wet ✓ Undifferentiated ✓ Agricultural ✓ Forestry ✓ Recycling ✓ Sawdust ✓ Woodchips ✓ Cereals ✓ Big Bag ✓ Hay ✓ Fodder ✓ Tubers ✓ Loading and Unloading Packages ✓ Bodies Indivisible ✓ Pallets ✓ Boxes ✓ Panels ✓ Profiles ✓ 33 europallet

___ **Utilisation:** ✓ Déchets ✓ Collecte et livraison des CDD ✓ Plastique ✓ Papier (en vrac et emballés) ✓ Humide ✓ Non différencié ✓ Agricole ✓ Forestier ✓ Recyclage ✓ Sciure ✓ Copeaux de bois ✓ Céréales ✓ Big Bag ✓ Foin ✓ Fourrage ✓ Tubercules- Chargement et déchargement de colis ✓ Corps indivisibles ✓ Palettes ✓ Caissons ✓ Panneaux ✓ Profilés ✓ 33 europalettes

___ **Gebrauch:** ✓ Abfälle ✓ Sammlung und Übertragung KAA ✓ Plastik ✓ Papier (unverpackt oder verschnürt) ✓ Biomüll ✓ Restmüll ✓ landwirtschaftlicher Abfall ✓ Waldabfälle ✓ Recycling ✓ Sägespäne ✓ Holzschnitzel ✓ Korn ✓ Big Bag ✓ Heu ✓ Grünfutter ✓ Knollenfrüchte ✓ Laden- und Entladen von Packstücken- unteilbare Gegenstände ✓ Paletten ✓ Kasten ✓ Platten ✓ Profile ✓ 33 Europaletten



Scigno E110

Weight (kg)	8800
Chassis and load-bearing structure	Continuous steel chassis. Side doors opening 12,3
Total weight (kg)	40000 / 45000
Suspensions	Air Suspensions with HALDEX, WABCO tridem SAF, ROR, JOST, BPW
Moving floor system	Cargo Floor® System or Keith Walking Floor®
Floor	21 or 24 alu profiles 6-8-10 mm
Walls	30 mm aluminium extruded profiles

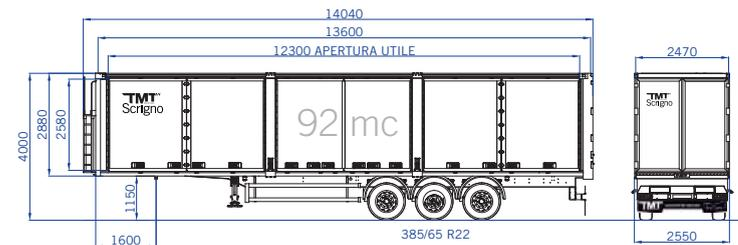
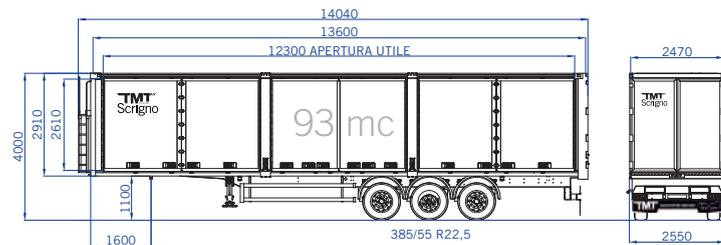

Conchiglia Frigo WF

Semirimorchi / Walking floor

È stato pensato e realizzato specificatamente per trasportare, con l'utilità del piano mobile, merci alimentari sfuse e/o pallettizzate a temperatura controllata e non.

___ **Utilizzo:** ✓ Frutta ✓ Verdura
✓ 33 europallet

It was designed and built specifically to transport loose and / or palletized food goods with controlled temperature and not, with the use of the walking floor.

___ **Use:** ✓ Fruit ✓ Vegetables
✓ 33 europallet

Elle a été conçue et construite spécifiquement pour le transport, avec l'utilité du fond mouvant, de produits alimentaires en vrac et/ou palettisés à température contrôlée ou non.

___ **Utilisation:** ✓ Fruits
✓ Légumes ✓ 33 europalettes

Er wurde speziell dazu entwickelt und verwirklicht, um mit Hilfe der beweglichen Ladefläche, unverpackte Lebensmittel und/ oder auf Paletten bei kontrollierter Temperatur oder auch nicht zu transportieren.

___ **Gebrauch:** ✓ Obst ✓ Gemüse
✓ 33 Europaletten



ATP APPROVED FOR TRANSPORT OF PERISHABLE FOODSTUFFS

Conchiglia Frigo

Weight (kg)	9500
Chassis and load-bearing structure	Continuous steel chassis, aluminium box bolted to the frame
Total weight (kg)	40000 / 45000
Suspensions	Air Suspensions with HALDEX, WABCO tridem SAF, ROR, JOST, BPW
Moving floor system	Cargo Floor® System or Keith Walking Floor®
Floor	21 or 24 alu profiles 6-8-10 mm
Walls	30 mm aluminium extruded profiles

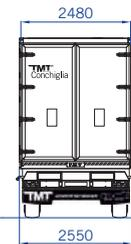
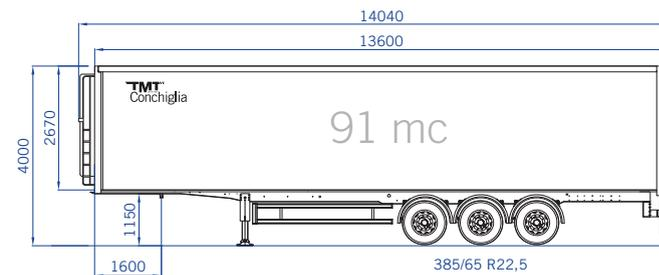
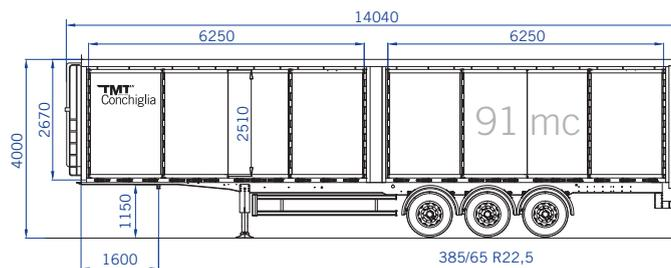

Leakproof

Semirimorchi / Walking floor

___ **Utilizzo:** ✓ Rifiuti ✓ Raccolta e conferimento CDR ✓ Plastica ✓ Carta (sia sfusi che imballati) ✓ Umido ✓ Indifferenziata ✓ Agricolo ✓ Forestale ✓ Riciclaggio ✓ 33 europallet

___ **Use:** ✓ Waste ✓ Collection and transfer RDF ✓ Plastic ✓ Paper (both loose and packed) ✓ Wet ✓ Undifferentiated ✓ Agri3cultural ✓ Forestry ✓ Recycling ✓ 33 europallets

___ **Utilisation:** ✓ Déchets ✓ Collecte et livraison des CDD ✓ Plastique ✓ Papier (en vrac et emballés) ✓ Humide ✓ Non différencié ✓ Agricole ✓ Forestier ✓ Recyclage ✓ 33 europallettes

___ **Gebrauch:** ✓ Abfälle ✓ Sammlung und Übertragung KAA ✓ Plastik ✓ Papier (unverpackt oder verschnürt) ✓ Biomüll ✓ Restmüll ✓ landwirtschaftlicher Abfall ✓ Waldabfälle ✓ Recycling ✓ 33 Europaletten



Conchiglia E110

Weight (kg)	8900
Chassis and load-bearing structure	Continuous steel chassis, aluminium box bolted to the frame
Total weight (kg)	40000 / 45000
Suspensions	Air suspensions with HALDEX, WABCO / tridem SAF, ROR, JOST, BPW
Moving floor system	Keith Walking Floor® Lp16
Floor	15 alu profiles 6+9. Waterproof van
Walls	30mm aluminium alloy extruded profiles

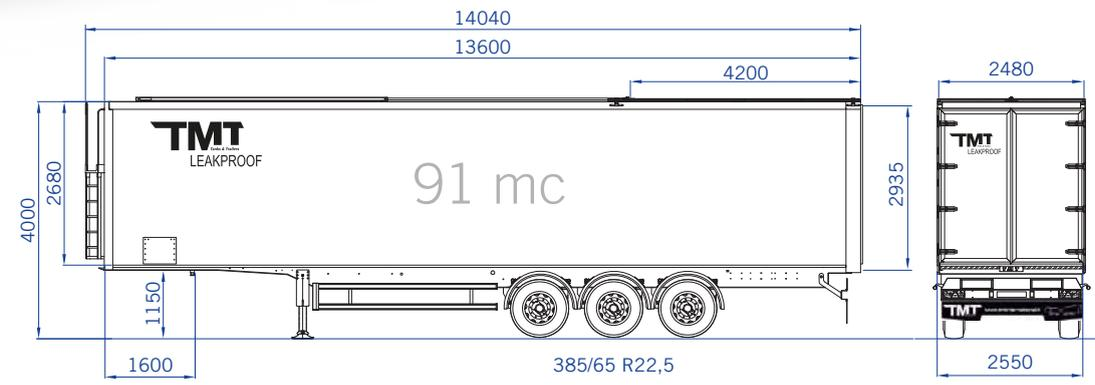

Intermodale WF

Semirimorchi / Walking floor

___ **Utilizzo:** Semirimorchio Intermodale Strada-Ferrovia compatibile con tratte P400 e carri poche C-D-E-F-G-H-I con selletta 98 cm. Questa versione omologata "Hupac" risponde alla normativa UIC 596-5.
✓ 33 europallet.

___ **Use:** Highway-Railway Intermodal semitrailer compatible with P400 sections and C-D-E-F-G-H-I wagons with 98 cm support element. This "Hupac" approved version complies with UIC 596-5.
✓ 33 europallets.

___ **Utilisation:** Semi-remorque intermodale route-rail compatible avec les sections P400 et quelques wagons C-D-E-F-G-H-I avec selle de 98 cm. Cette version approuvée "Hupac" est conforme à la norme UIC 596-5.
✓ 33 europallettes.

___ **Gebrauch:** Intermodaler Schubboden für Straße-Bahn, kompatibel mit P400-Abschnitten und wenigen C-D-E-F-G-H-I-Wagen mit 98-cm-Sattel. Diese von "Hupac" genehmigte Version entspricht UIC 596-5.
✓ 33 Europaletten

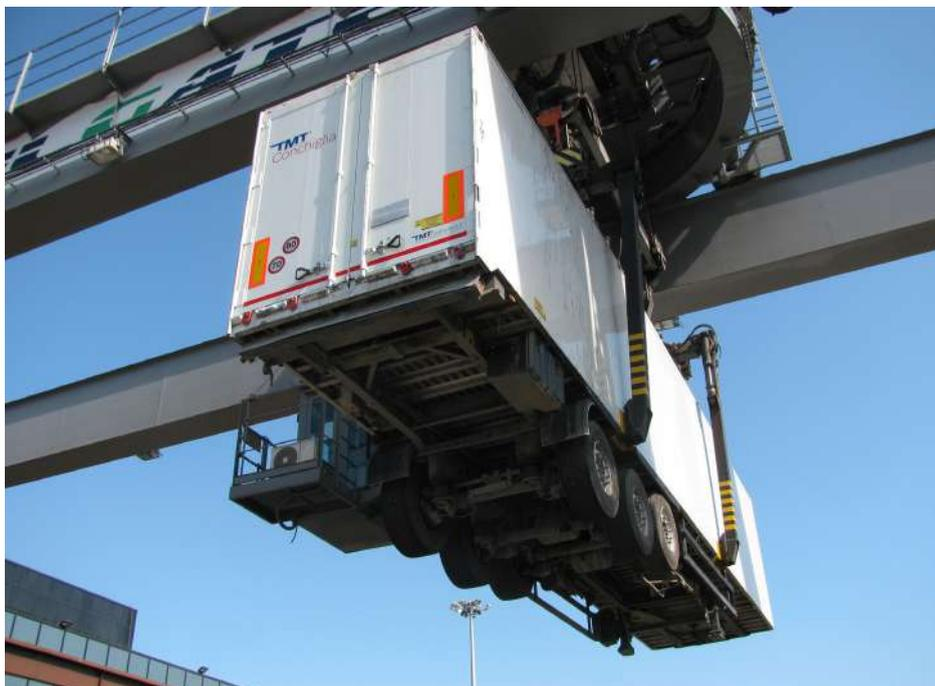

Intermodale E60

Weight (kg)	8000
Chassis and load-bearing structure	Continuous steel chassis, aluminium box bolted to the frame
Total weight (kg)	38000
Suspensions	Air suspensions HALDEX, WABCO / tridem SAF, ROR, JOST, BPW
Moving floor system	Cargo Floor® System or Keith Walking Floor®
Floor	21 or 24 alu profiles 6-8-10 mm
Walls	30 mm aluminium extruded profiles

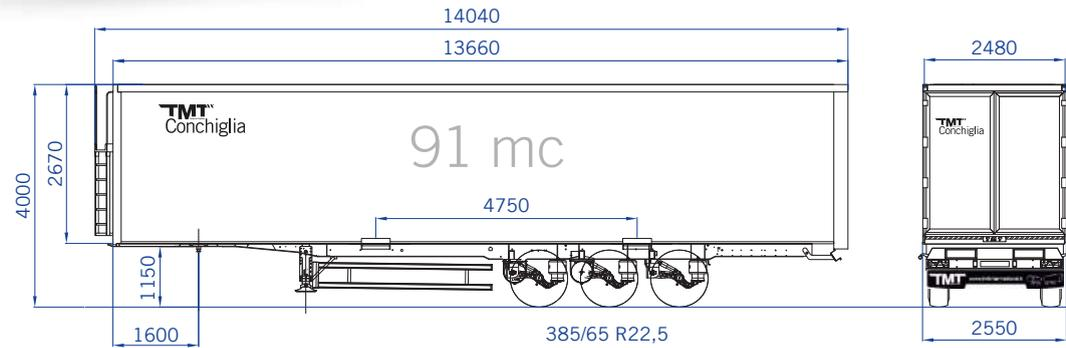

Container WF

Container

Container Walking Floor innovativo in acciaio S-400 da 45' per il trasporto strada ✓ mare ✓ ferrovia. Omologato per una portata massima di 29500kg è adatto al trasporto di tutte le merci sfuse abitualmente trasportate con i Walking Floor®. ✓ 33 europallet

45' High Cube Open Top Pallet Wide innovative container Walking Floor in S-400 for highway - sea - railway transport. Approved for a maximum capacity of 29500kg, it is suitable for transporting all loose goods usually carried with Walking Floor®. ✓ 33 europallets

Container fond mouvant innovateur en S-400 de 45' pour le transport routier, maritime et ferroviaire. Le container homologué pour une portée maximale de 29500 kg est indiqué pour le transport de toutes les marchandises en vrac normalement transportées avec les Walking Floor®. ✓ 33 europalettes

45 'High Cube Open Top Pallet Wide innovativer Container Schubboden in S-400 für Transport auf Straße ✓ Meer ✓ Bahn. Der homologierte Container für eine maximale Füllung von 29500kg ist für den Transport allen Schüttguts geeignet, das normalerweise mit den Walking Floor® transportiert werden. ✓ 33 Europaletten



Container WF

Weight (kg)	7200
Chassis and load-bearing structure	Container with moving floor
Moving floor system	Cargo Floor® System or Keith Walking Floor®
Floor	21 alu profiles 6-8-10 mm
Walls	plate 3mm in high strenght steel







Innovazione Tecnologica 2019

Si attesta che la ditta
TMT TANKS & TRAILERS
 ha partecipato ad Ecomondo - Key Energy
 presentando un brevetto innovativo

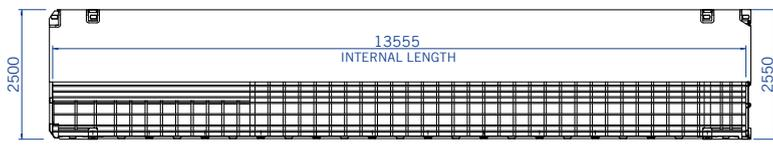
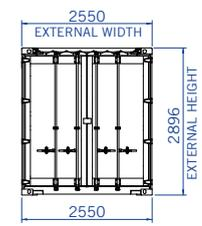
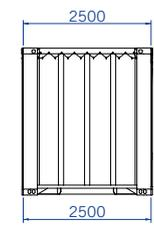
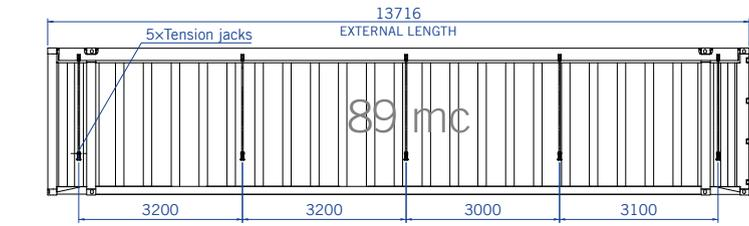

5 - 8 NOVEMBER 2019 RIMINI EXPO CENTRE - ITALY



PROFILI \ PROFILES \ PROFILEN \ PLANCHERS

BEARINGS



SPLASH GUARD
HOLD-DOWN



3003 BEARING

LEAK PROOF (15 SLAT)



PRESSURE SEAL® LITE



V-18 SERIES

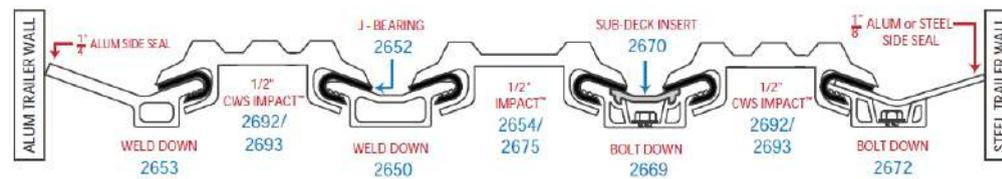

V-9 SERIES

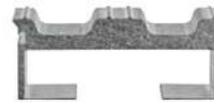
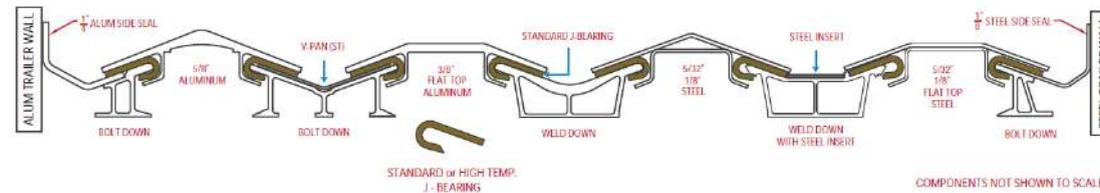

Alu profile 8-18/112mm HDI
(art. no. 30.0695)



Alu profile 8/112mm SLP ribbed
(art. no. 72.2988)
possible with SLP-channel
(art. no. 755.4525)



Alu 10/133mm Leak Proof
deckslat HD (Heavy Duty)
(art. no. 89.3497)



Non moving sideprofiles



Alu profile 10/112mm ribbed
(art. no. 25.0550)



Alu profile 6/112mm ribbed
(art. no. 20.0360)



Alu profile 6/112mm-DS ribbed
(art. no. 21.0549)

STANDARD CARGO FLOOR SYSTEM

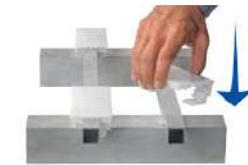

OPTIONALS



ADR kit with fire extinguisher, PVC fire extinguisher holder, neutral folding table on the rear and 3 diamond tables per side (right, left, rear)



Underchassis toolbox double side openable 2400x950x380 thickness 1,5mm



Pressure gauge 0-10 bar connected to diaphragm for the approximation of the transported weight



Spare wheel bracket for 1/2 spare wheel



- Foldable "R" waste transport sign Italy model
- 4 wing nuts kit for greater sealing of rear doors



Wabco smart board for axle weight control

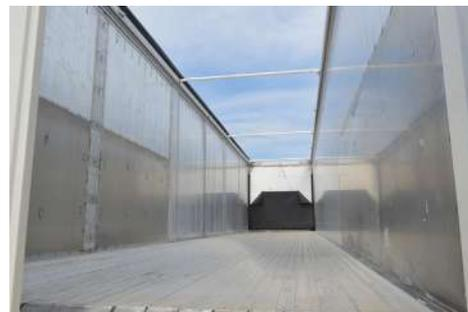

Inside aluminium protection (different dimensions)



- Foldable "A" waste transport sign German model
- Pneumatic safety lock on rear doors



All closed pallet box, 36 or 24



Compressed air quick coupling with the gun and hose in the rear part of the vehicle for cleaning the loading floor



Extra hydraulic/electric connections on the left



- KM-Counter stud
- 6 studes inox steel

OPTIONALS



Shorter semi-trailer



- IMO hooks for ferry boats
- Anchor hooks for highway-sea intermodal transport



Hydraulic Roof



Rear rubber buffers



- LED headlights
- Stainless steel bumper



- PVC toolbox 800x500x500 / 100x500x500
- 25 liters tank with soap holder



Walking Floor Remote control



6 mudguards



JOST landing gear



Inox steel toolbox 800x500x500 super mirror



Pneumatic floor sheet set



120-liters tank installed on the front of the semi-trailer

OPTIONALS



Rear door with hydraulic opening system



Openable rear roof upside frame / and liftable



Front and rear painting in a different color than the side wall / Two-tone painting / No-painting



13+13 / 18+18 / 23+23 Load retaining hooks 5 ton model



Full opened pallet box, 24



Metallic or pearly colour paint



Moving headboard



Work light kit (R, L, ant. telescopic)



Semi-waterproof walking floor with 21 slats with rear water collection tank of about 50/300 liters with side discharge



Document holder



6 chrome wheel nut covers



- Sheet with supports on one fix side
- Cut resistant sheet Carapax



Pneumatic tipping bumpers



Four locking bars on rear doors



Window for load inspection

Portacontainer



1



2



3



4

Portacontainer per il trasporto specifico di containers e casse mobili

- Pianalato (1)
- Collo d'oca (2)
- Allungabile (3)
- Scheletrato (4)

Container Chassis for the transport of containers and swap bodies

- Flat (1)
- Gooseneck (2)
- Extensible (3)
- Skeleton (4)

Porte-container pour le transport de conteneurs et de caisses mobiles

- Avec plancher (1)
- Col de cygnet (2)
- Extensible (3)
- Squelette (4)

Containerträger für den Transport von Containern und beweglichen Kasten

- Ladefläche (1)
- Schwanenhals (2)
- Verlängerbar (3)
- Skelem (4)



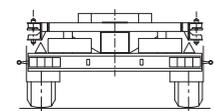
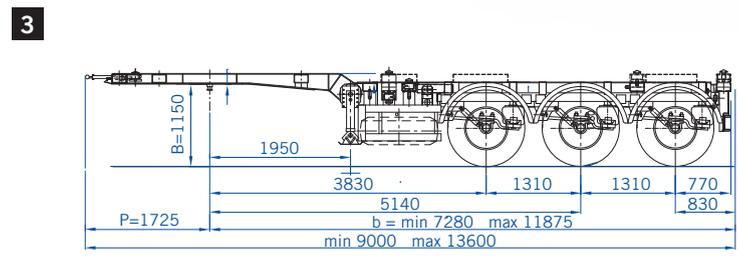
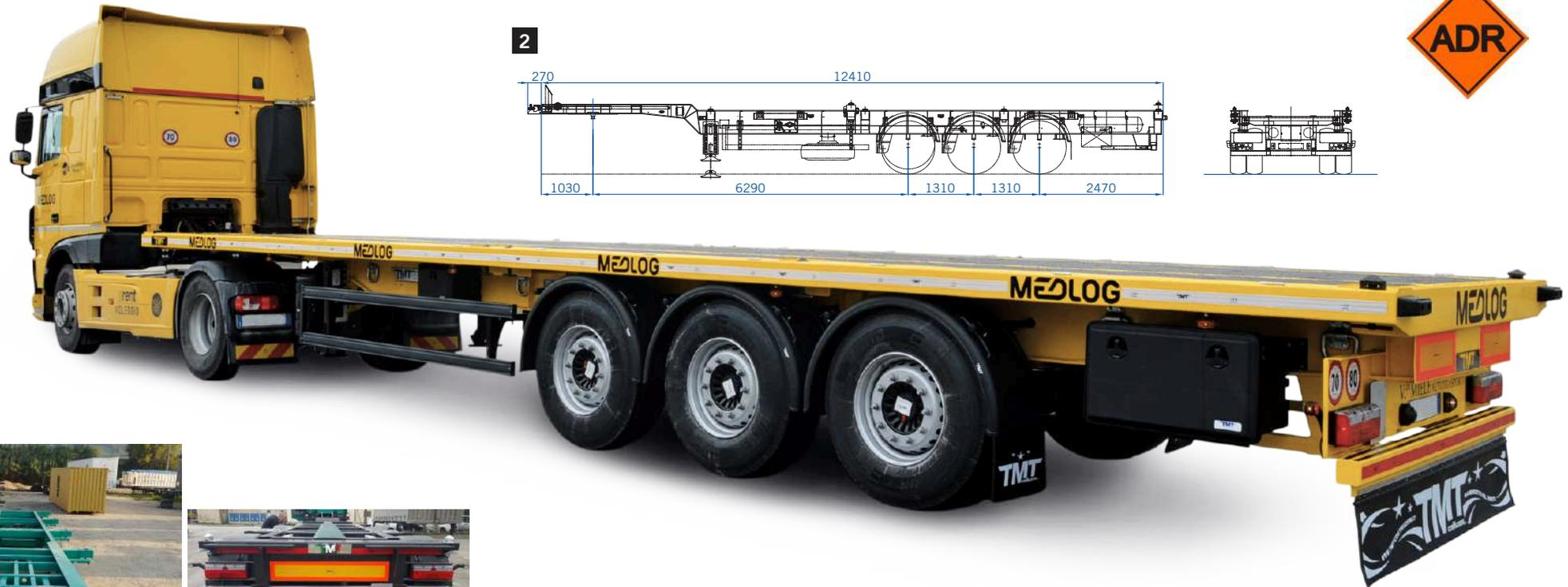
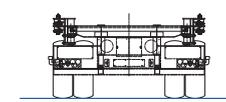
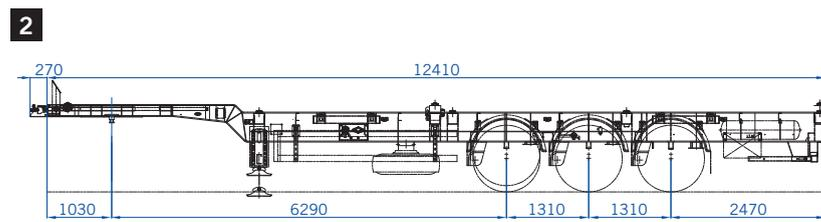
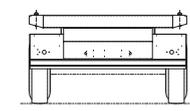
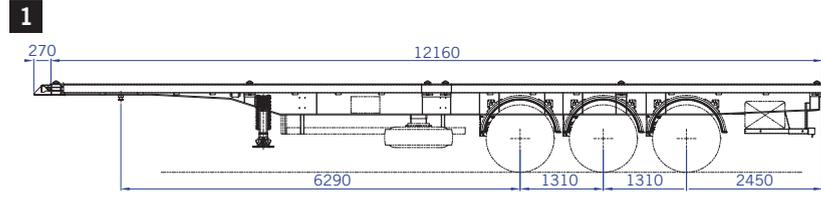

Cisterna Rifiuti

Waste Tank

___ **Utilizzo:** ✓ Rifiuti ✓ Oli esausti

___ **Use:** ✓ Waste ✓ Waste Oil

___ **Utilisation:** ✓ Déchets ✓ Huiles usages

___ **Gebrauch:** ✓ Abfälle ✓ Verbrauchte Öle

7450 Lt

19100 Lt

7450 Lt



Available Versions

- One-compartment 34000 Lt
- Two-compartments 21000 Lt + 13000 Lt

10,5 mt (Available also 11,5 mt)



Cisterna Carburanti

Fuel Tank



___ **Utilizzo:** ✓ Carburanti
✓ Benzina ✓ Gasolio ✓ Jet-A1

___ **Use:** ✓ Fuels ✓ Petrol ✓ Diesel
Fuel ✓ Jet-A1

___ **Utilisation:** ✓ Carburants
✓ Essence ✓ Gazole ✓ Jet-A1

___ **Gebrauch:** ✓ Kraftstoffe
✓ Benzin ✓ Diesel ✓ Jet-A1



Tanks

___ **Utilizzo:** ✓ Carburanti ✓ Acqua
✓ Rifiuti ✓ Oli esausti

___ **Use:** ✓ Fuels ✓ Water ✓ Waste
✓ Waste Oil

___ **Utilisation:** ✓ Carburants
✓ Eau ✓ Déchets ✓ Huiles
usages

___ **Gebrauch:** ✓ Treibstoffe
✓ Wasser ✓ Abfälle
✓ Verbrauchte Öle



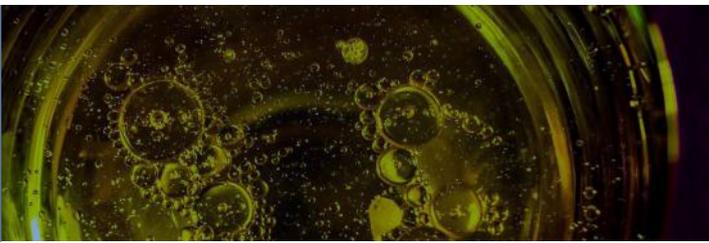

IMPIANTI \ Progettazione, costruzione ed assistenza di impianti per lo stoccaggio, il pompaggio e la misurazione di prodotti petroliferi con sistemi integrati per il monitoraggio dei serbatoi interrati (controllo tenuta, controllo livello prodotto), lo scarico e la distribuzione (modello “piping”). Tali impianti sono progettati, realizzati e collaudati secondo i requisiti richiesti e nel rispetto delle normative vigenti; possono essere installati in porti commerciali e turistici, in aeroporti militari e civili e in depositi privati.

Novità: Impianto ingegnerizzato e di altissima tecnologia per il trasporto dei rifiuti.

PLANTS \ Design, construction and assistance of plants for storage, pumping and measurement of petroleum products with integrated systems for monitoring underground tanks (leakage control, product level control), unloading and distribution (“piping” model).

These systems are designed, manufactured and tested according to the requirements and in compliance with the regulations in force; they can be installed in commercial and tourist ports, in military and civil airports and in private depots.

New: Engineered plant with very high technology for waste transport.



I NOSTRI SERVIZI

- **Assistenza semirimorchi:** assistenza tecnica sui semirimorchi Walking Floor®
- **Assistenza autobotti:** team altamente specializzato, depositi e autobotti civili e militari

OUR SERVICES

- **Technical support semi-trailers:** technical support for semi-trailers Walking Floor®
- **Technical support for tank trucks:** highly skilled personnel, civilian or military depots and tank trucks

INSTALLATIONS

\ Conception, construction et assistance d'installations de stockage, de pompage et de mesure de produits pétroliers avec des systèmes intégrés de surveillance des réservoirs souterrains (contrôle d'étanchéité, contrôle du niveau des produits), de vidage et de distribution (modèle «piping»). Ces installations sont conçues, construites et testées selon les exigences et dans le respect de la réglementation en vigueur; ils peuvent être installés dans les ports commerciaux et touristiques, dans les aéroports militaires et civils et dans les dépôts privés.

Nouveautés: Installation de haute technologie et d'ingénierie pour le transport des déchets.

BETRIEBSANLAGEN

\ Entwicklung, Herstellung und Assistenz der Anlagen für Lagerung, Pumpen und Messen der Erdölprodukte mit integrierten Systemen zur Überwachung der unterirdischen Tanks (Dichtheitsprüfung, Füllstand), die Entladung und Verteilung (Modell „piping“). Diese Anlagen wurden entwickelt, hergestellt und geprüft in Anlehnung an die Zulassungsvoraussetzungen und den geltenden Gesetzenormen und sie können in Handels- und Touristenhäfen, in militärischen und zivilen Flughäfen und in privaten Lagern installiert werden.

Neuigkeiten: Technische Anlage höchsten Niveaus für den Abfalltransport.



NOS SERVICES

- **Assistance semi-remorques fond mouvant:** assistance technique sur les remorques Walking Floor®
- **Assistance camiones-citernes:** une équipe hautement spécialisée, dépôts et camions-citernes civils et militaires

UNSERE SERVICE

- **Assistenz für Schubboden:** Technische Assistenz an den Schubboden Walking Floor®
- **Assistenz für die Tankwagen:** Hoch spezialisiertes Team. Lager und Zivile und Militärische Tankwagen

CERTIFICAZIONI E RICONOSCIMENTI \ CERTIFICATIONS AND RECOGNITIONS



ISO 9001 certification



Leader della crescita Il Sole 24 Ore: 4° su 400 aziende



Financial Times 1000: 53rd company that achieved the highest compound annual growth



Ecomondo ✓ TMT's Container Technological Innovation 2019



Trailer Innovation 2021: TMT's Scrigno nomination



Trailer Innovation 2021: Category Smart Trailer



Conformità Produzione in Serie



EC TYPE Approval Certificate



XL Certification



N/CAGE AH177 Certification



TMT Tanks & Trailers
Via Del Terziario 18/20
63076 Monteprandone (AP)

tel. (+39) 0735 56 82 85
fax (+39) 0735 56 02 44
info@tmtinternational.it

www.tmtinternational.it