

Volume 01

2020

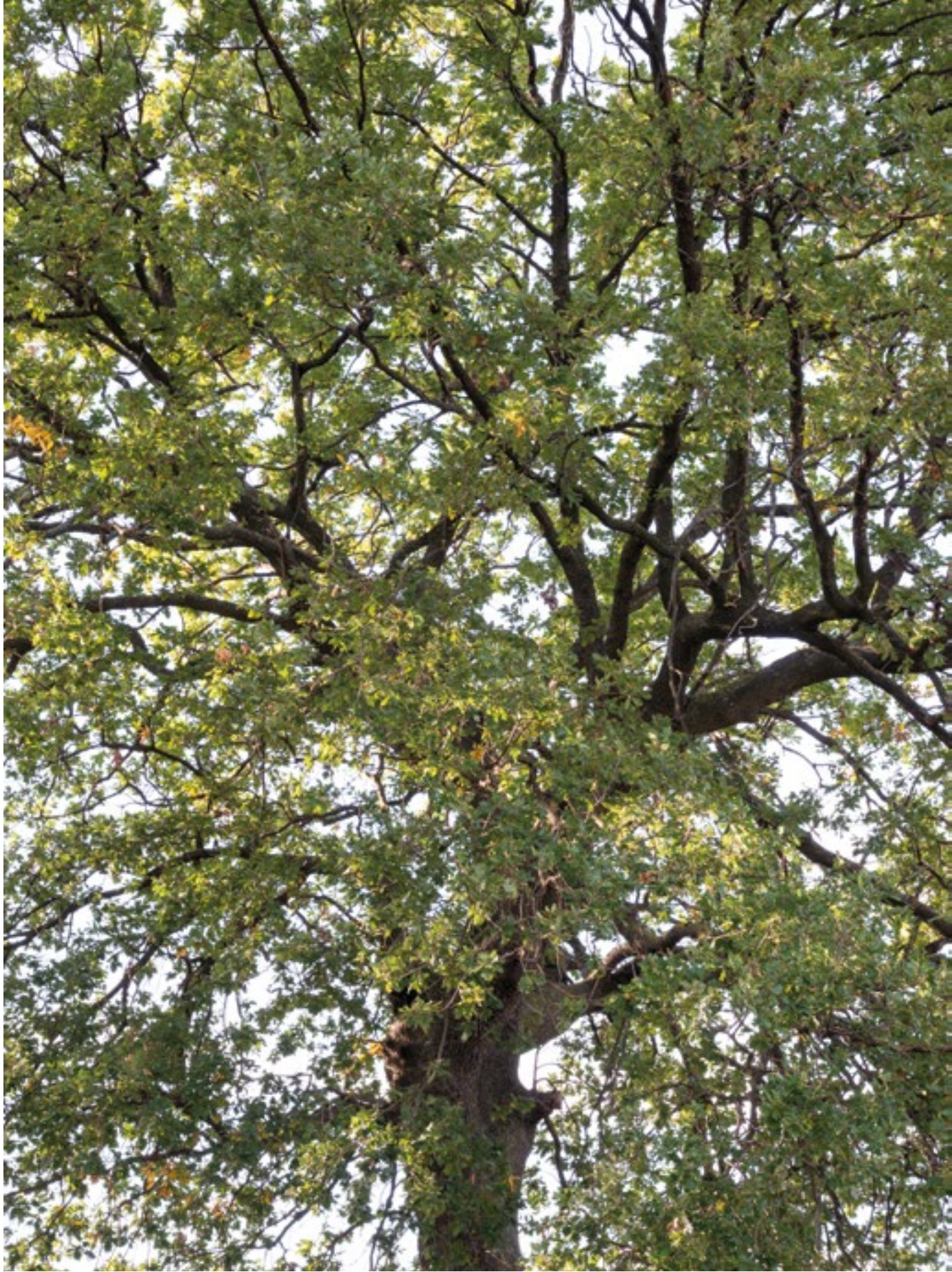



L'azienda	The company	8
La collezione	The collection	12
Prodotti	Products	17
Tavolo rettangolare	2017	20
Tavolo quadrato	2017	36
Credenza	2017	44
Credenza bassa	2017	58
Mensola	2017	70
Multiuso	2017	84
Modulare	2017	100
Paravento	2018	124
Specchio tondo	2018	136
Specchio rettangolare	2018	142
Schede tecniche	Technical sheet	145
Avvertenze	Instructions	146
Elenco materiali in uso	List of materials used	147
Dichiarazione	Disclaimer	148
Tavolo rettangolare	2017	149
Tavolo quadrato	2017	150
Credenza	2017	151
Credenza bassa	2017	152
Mensola	2017	153
Multiuso	2017	154
Modulare	2017	155
Paravento	2018	156
Specchio tondo	2018	157
Specchio rettangolare	2018	158

Volume 01

2020





Unopervolta è un'azienda che vive in Abruzzo. Nasce da una falegnameria tradizionale, forte di una estrema capacità e attenzione nella lavorazione del legno.

Queste qualità vengono conservate con cura da una giovane proprietà, che vuole dare alla tradizione una vita contemporanea.

Unopervolta vuole creare mobili di qualità, utili e raffinati. Oggetti semplici, veri.

Unopervolta crea la sua collezione di prodotti con la certezza che nella normalità delle cose si possa nascondere la magia.

Unopervolta is a company based in Abruzzo, Italy. Born from a traditional carpentry, strong of an extreme ability and attention in the woodworking.

These qualities are carefully preserved by a young property, which wants to give tradition a contemporary life.

Unopervolta wants to create quality, useful and refined furniture. Simple, real objects.

Unopervolta creates its collection of products with the certainty that magic can be hidden in the normality of things.

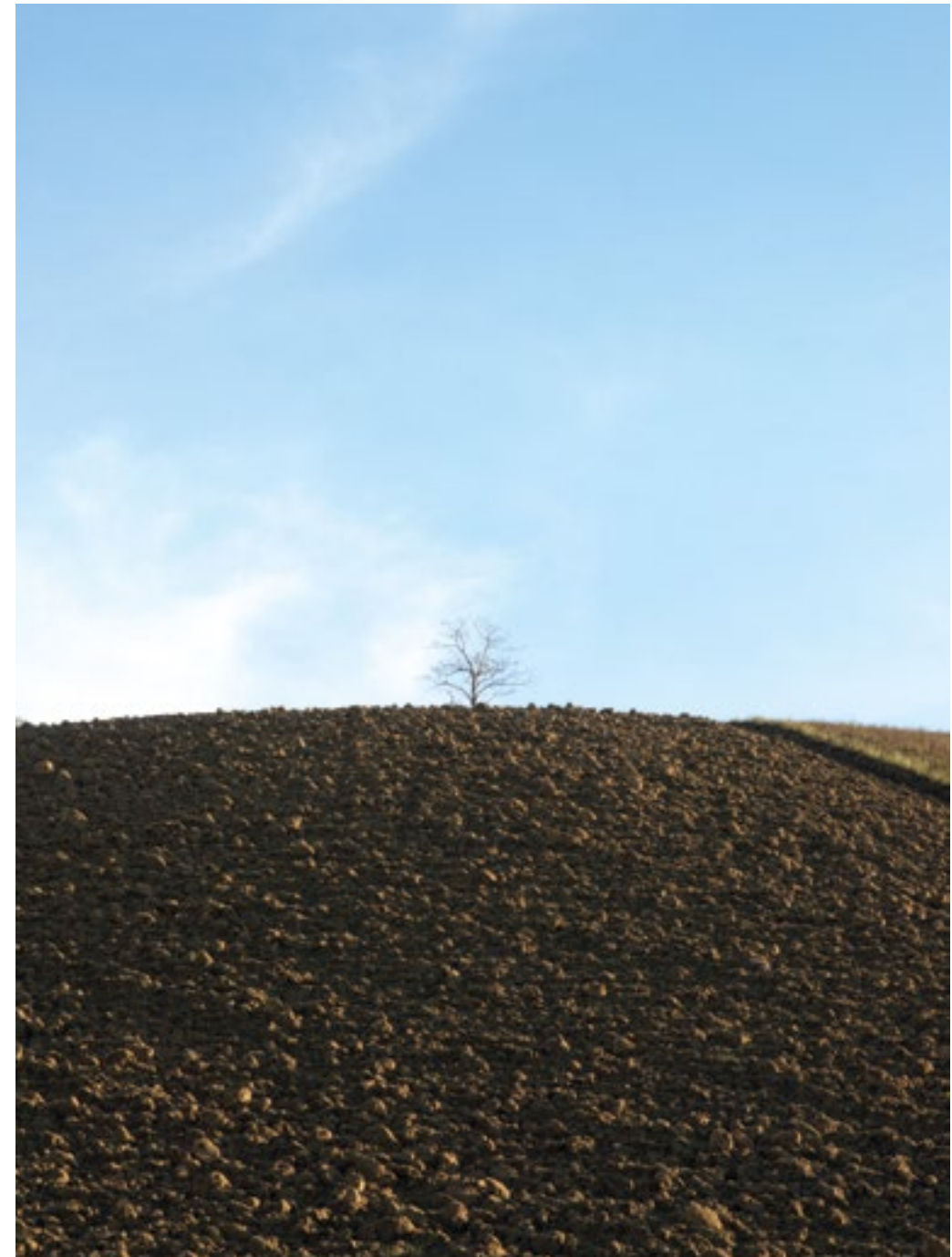

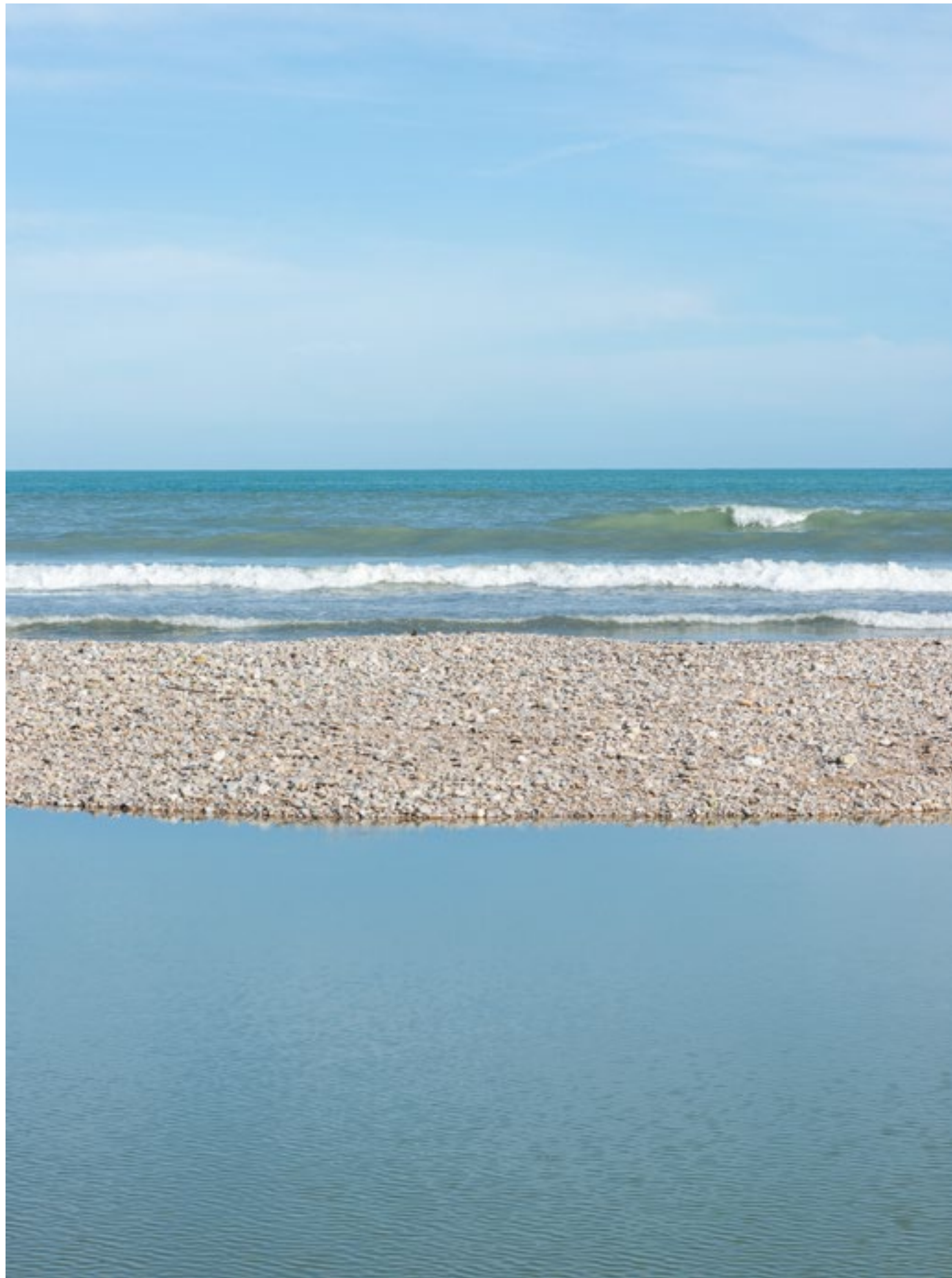

La collezione Unopervolta accoglie prodotti capaci di convivere per creare un ambiente leggero, personale e semplice.

Oggetti dalle giuste dimensioni, capaci di adattarsi a vari ambienti della casa.

La memoria e l'assenza sono i riferimenti concettuali del progetto. Oggetti comuni della tradizione locale, vengono reinterpretati per creare una collezione sobria e senza tempo.

Il legno è il tema. Altri materiali semplici, come il ferro, sono coinvolti nella narrazione.

The Unopervolta collection includes products that can coexist to create a light, personal and simple environment.

Objects with the right dimensions, capable of adapting to various rooms in the house.

Memory and absence are the conceptual references of the project.

Common objects of the local tradition are reinterpreted to create a sober and timeless collection.

Wood is the theme. Other simple materials, such as iron, are involved in the narrative.



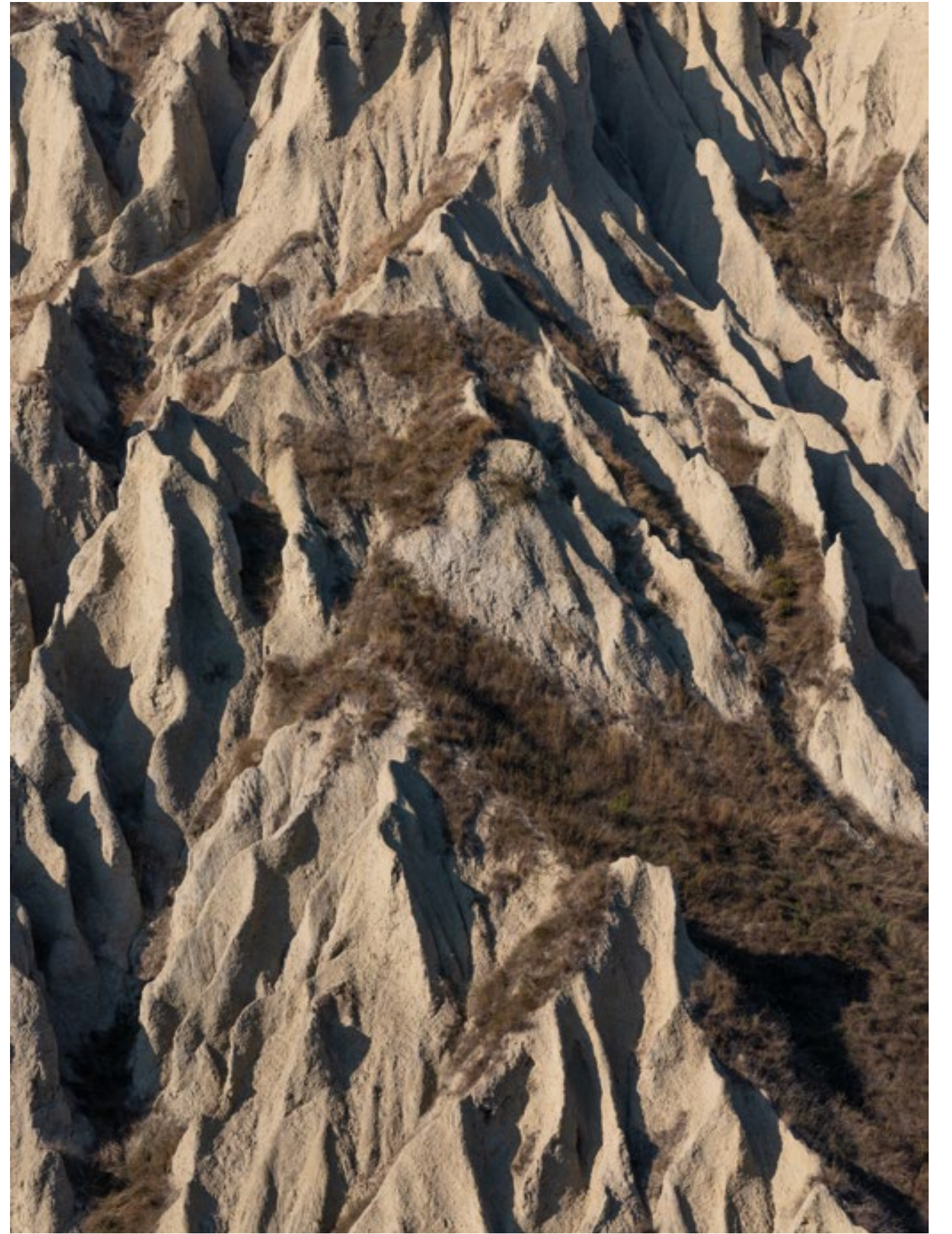





Tavolo rettangolare 2017

Quattro sottili gambe in metallo verniciato sorreggono un piano in legno massiccio di Noce nazionale. Nella forma rettangolare e in quella quadrata il tavolo conserva un disegno semplice dal tratto ingenuo e rigoroso.

Four thin painted metal legs support a solid european walnut top. In the rectangular and square shape the table keeps a simple design with a naive and rigorous line.







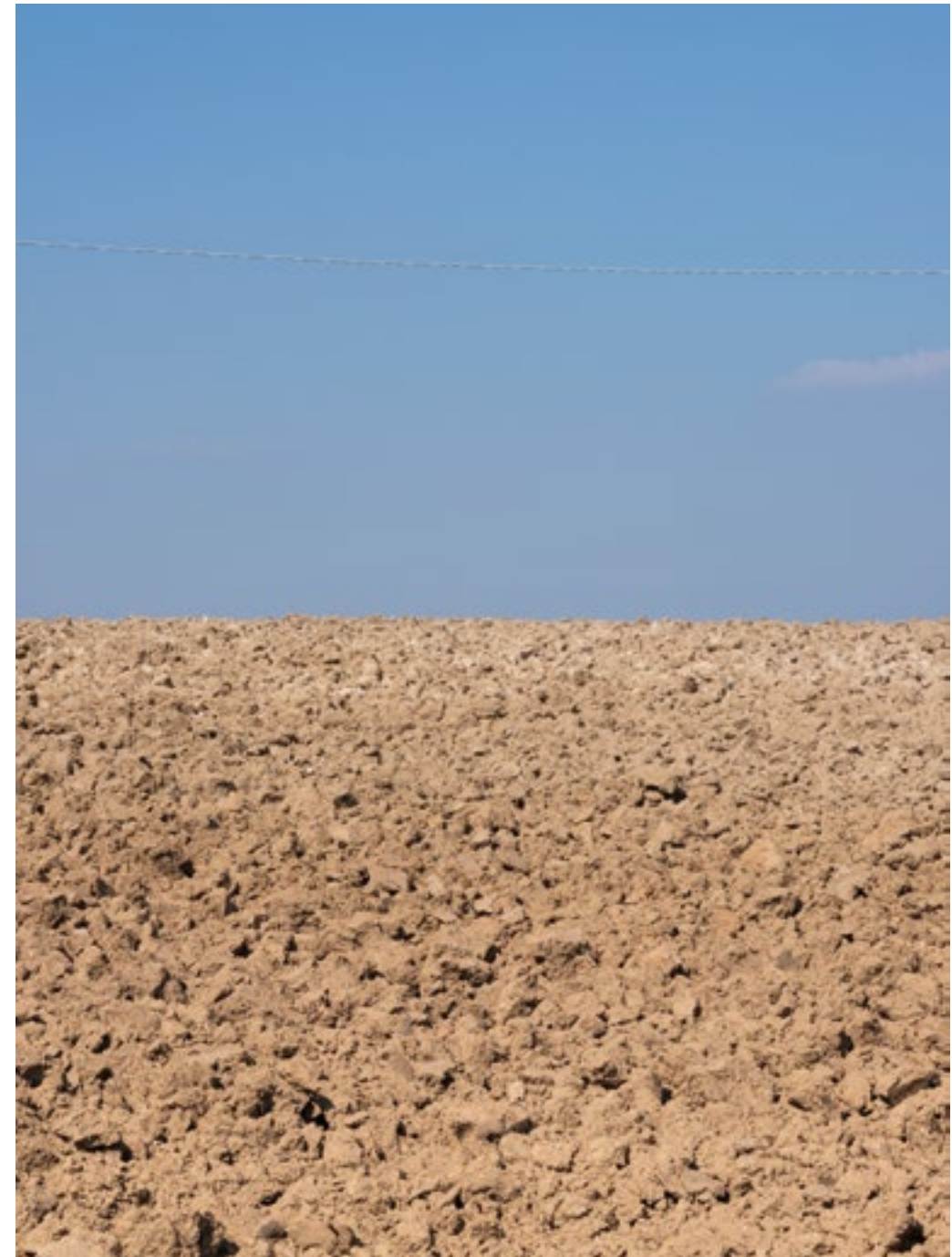

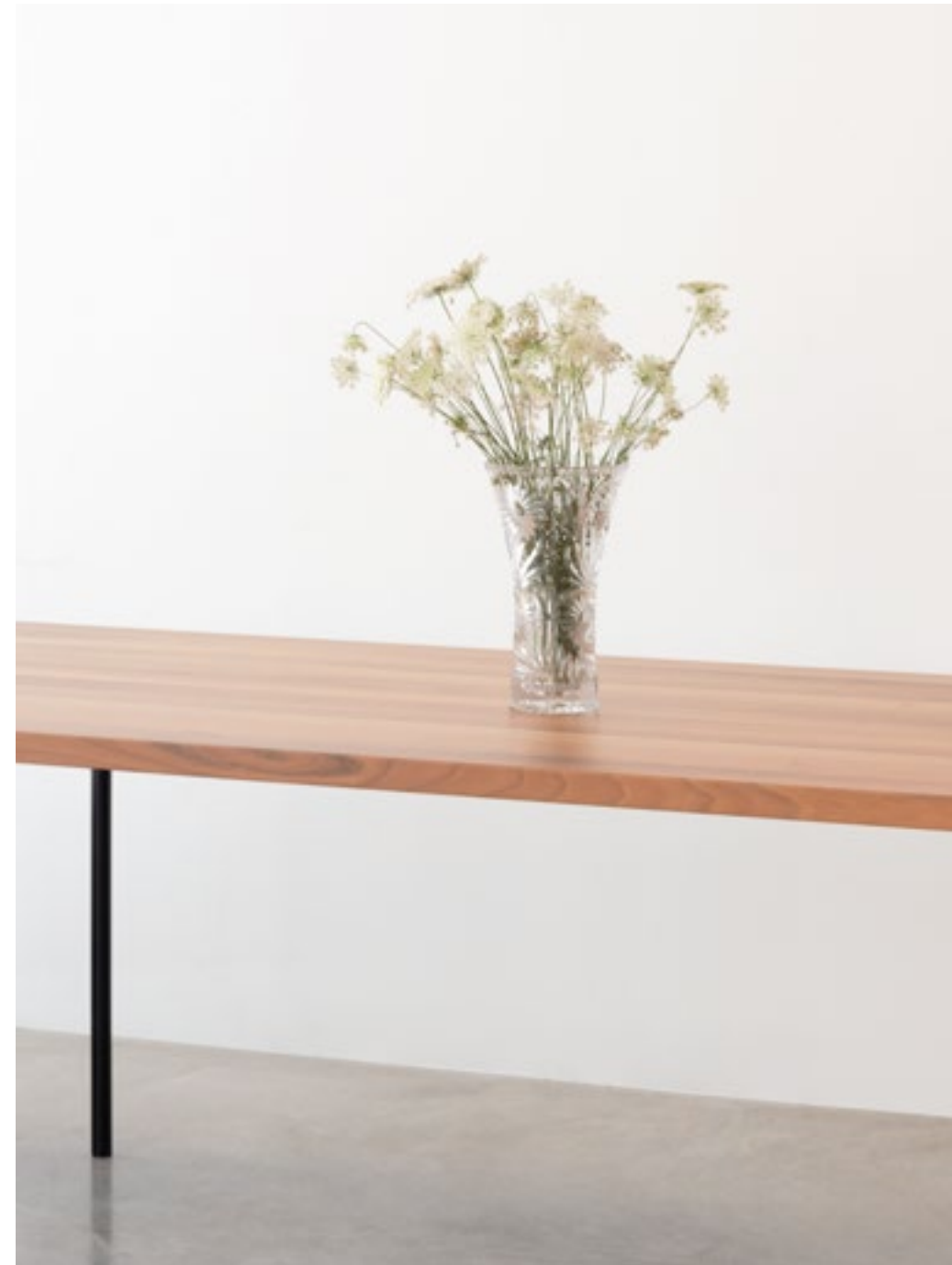







Tavolo quadrato

2017



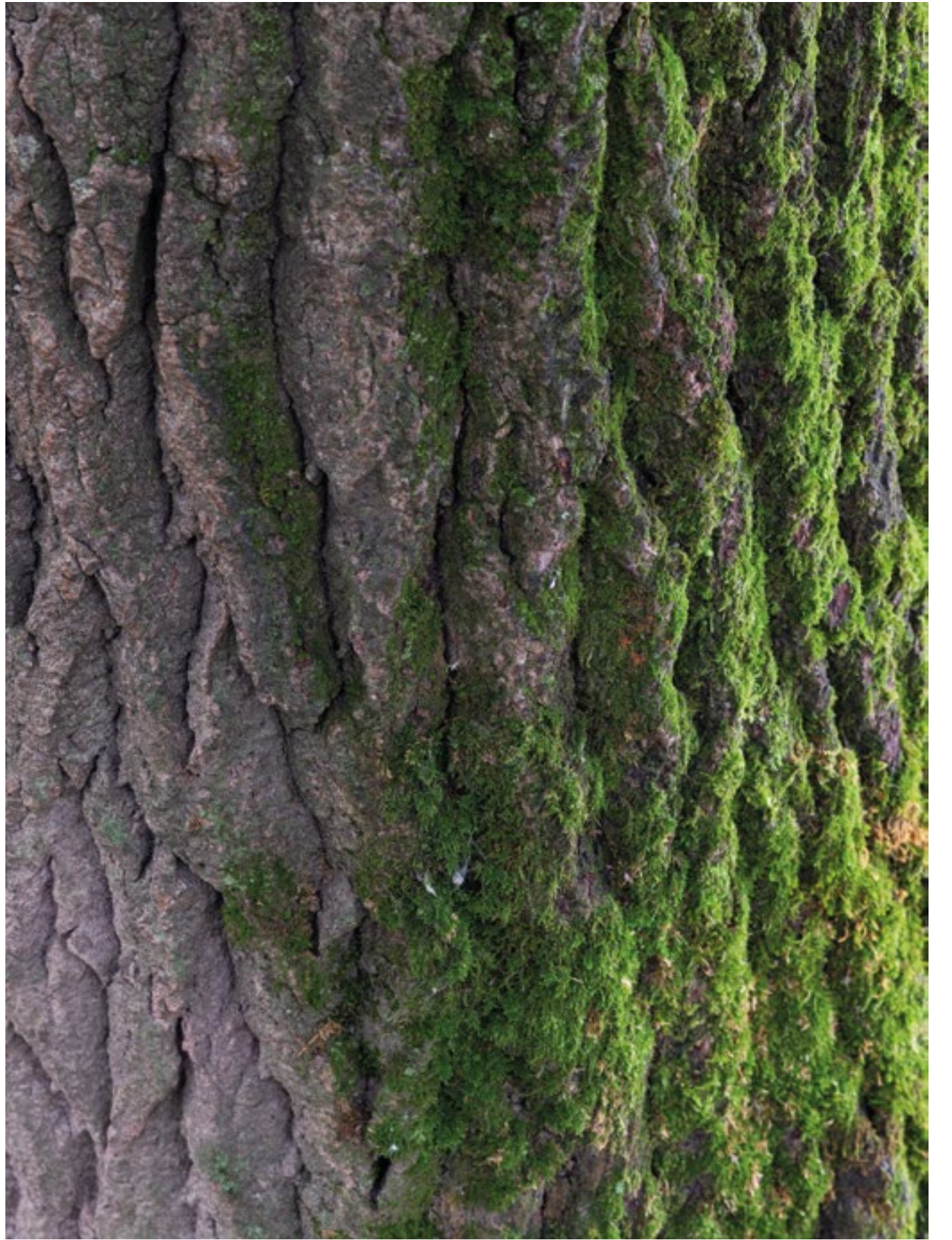





Credenza

2017

Un contenitore dalla forma rettangolare ospita ripiani laccati scuri dentro un involucro in legno. Ante in noce e lamiera forata in cornici e definiscono un mobile dal sapore sospeso tra memoria e presente.

A rectangular container hosts dark lacquered shelves inside a wooden casing.

The doors in walnut and the perforated sheet metal frames, defines a piece of furniture suspended between memory and present.





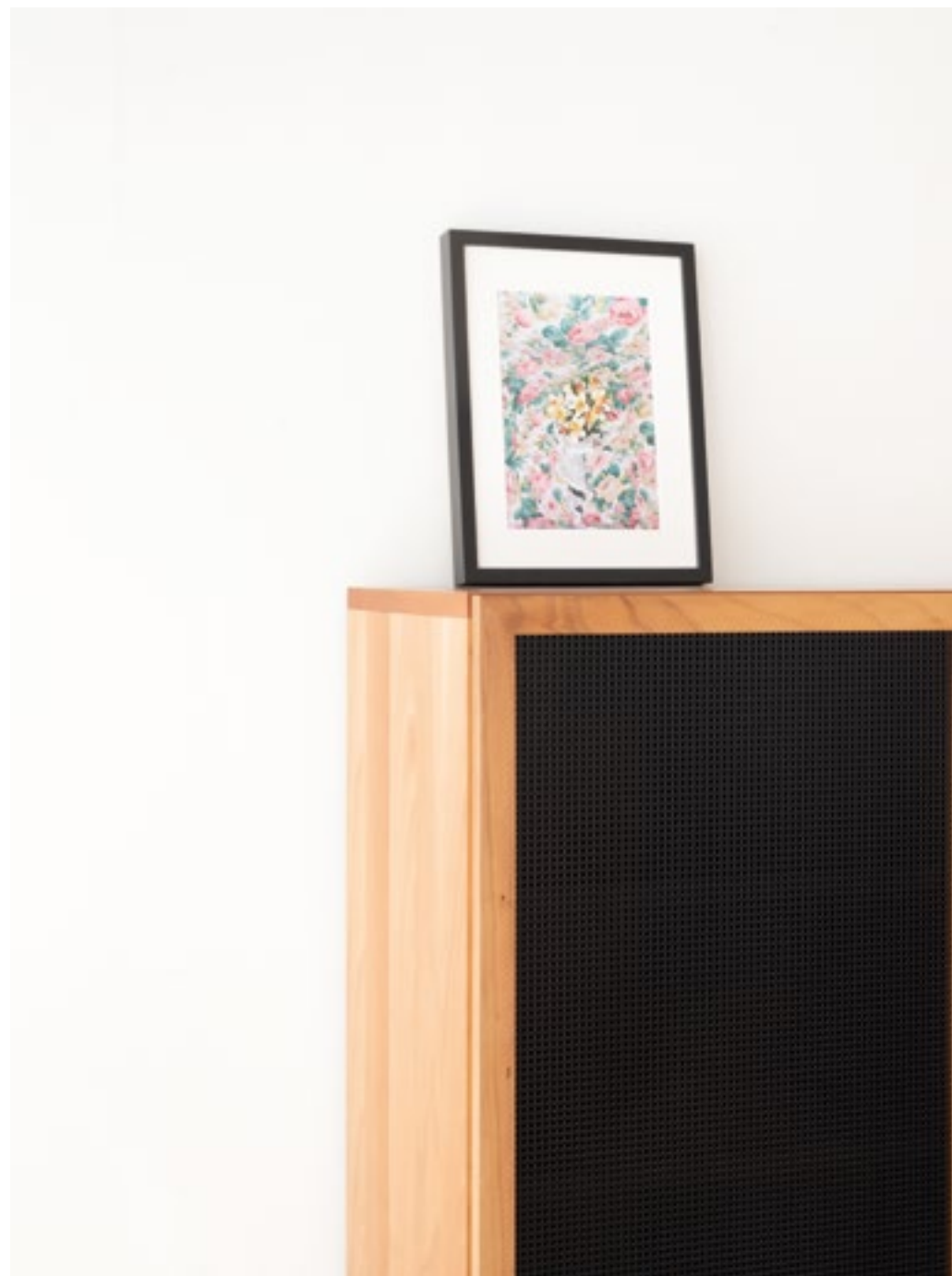









Credenza bassa

2017

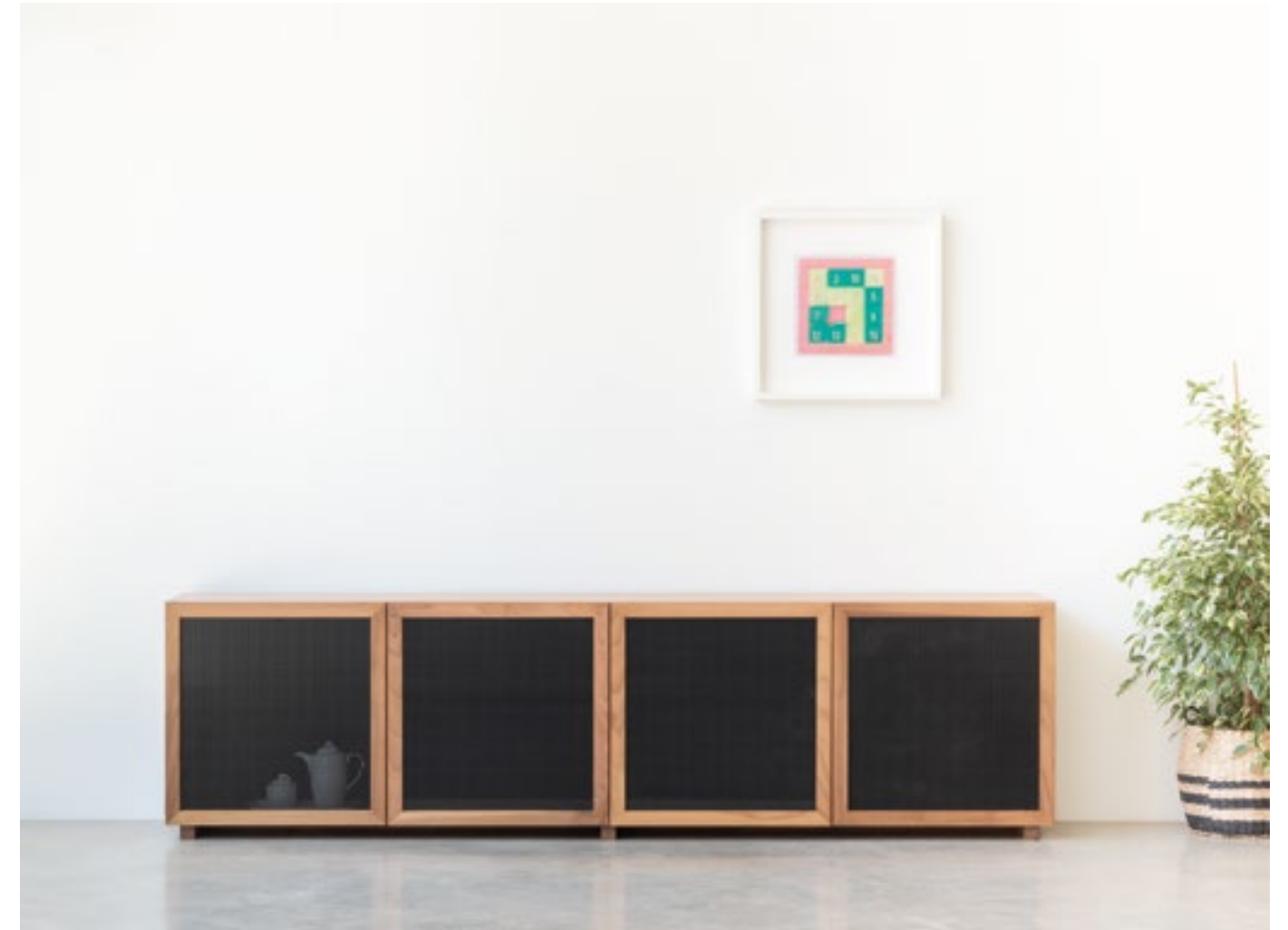



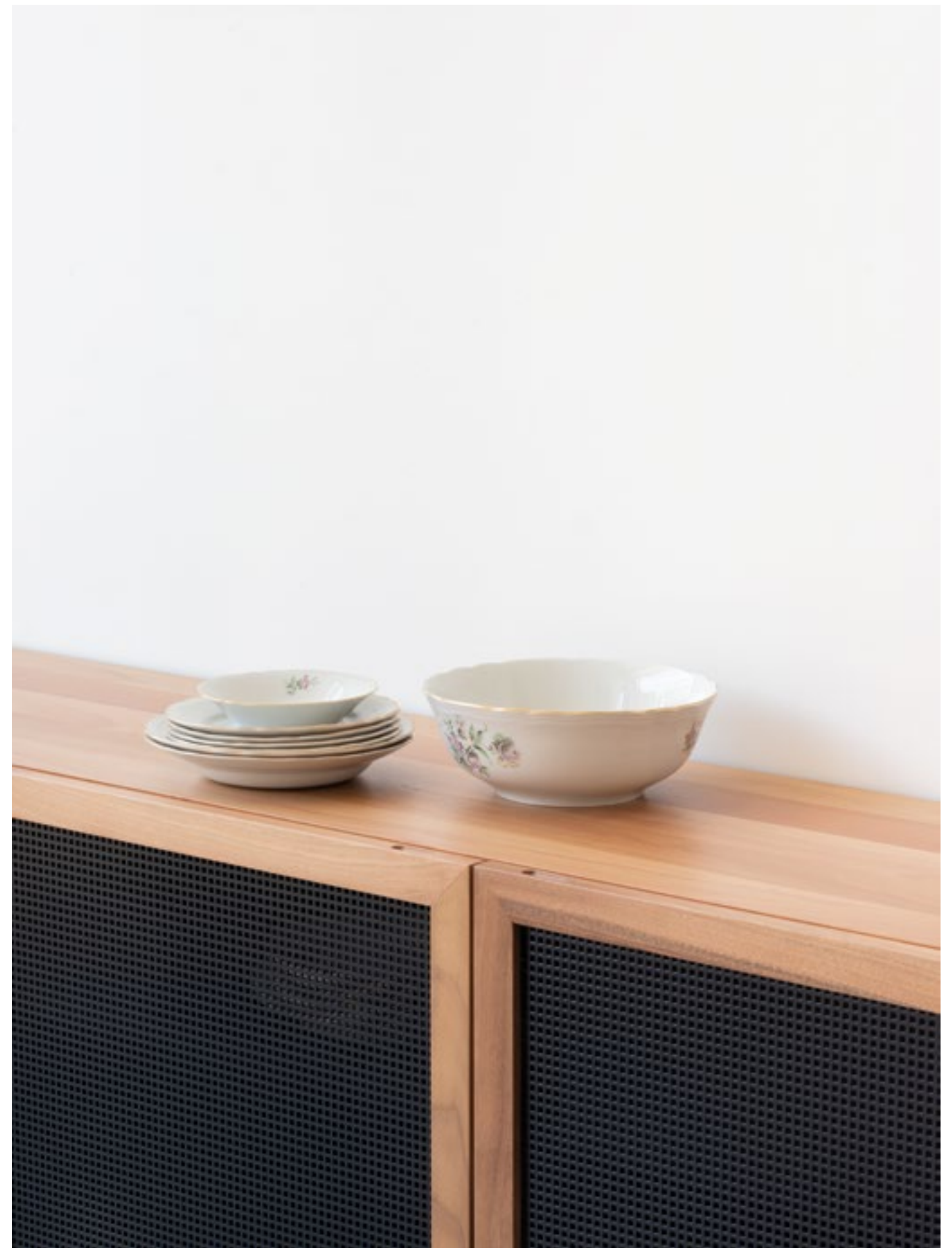







Mensola

2017

Mensola e schienale in listelli di noce vengono tenuti insieme da due sottili guance triangolari in metallo verniciato.

La forma semplice e primitiva regala alla mensola l'opportunità di essere utilizzata con varie funzioni nei diversi spazi della casa.

Shelf and back in walnut strips are held together by two thin triangular cheeks in painted metal.

The simple and primitive shape gives the shelf the opportunity to be used with various functions in the different areas of the house.

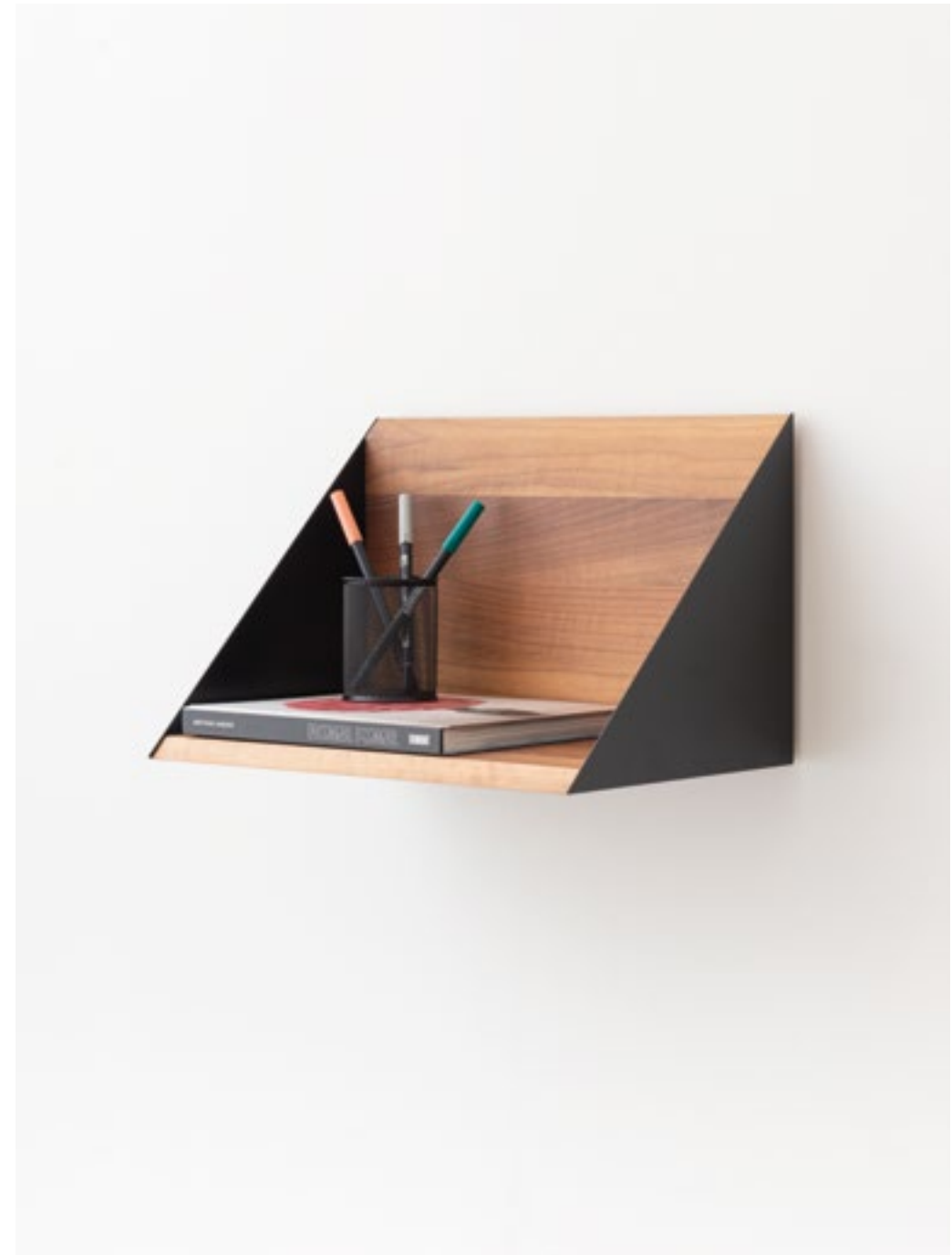

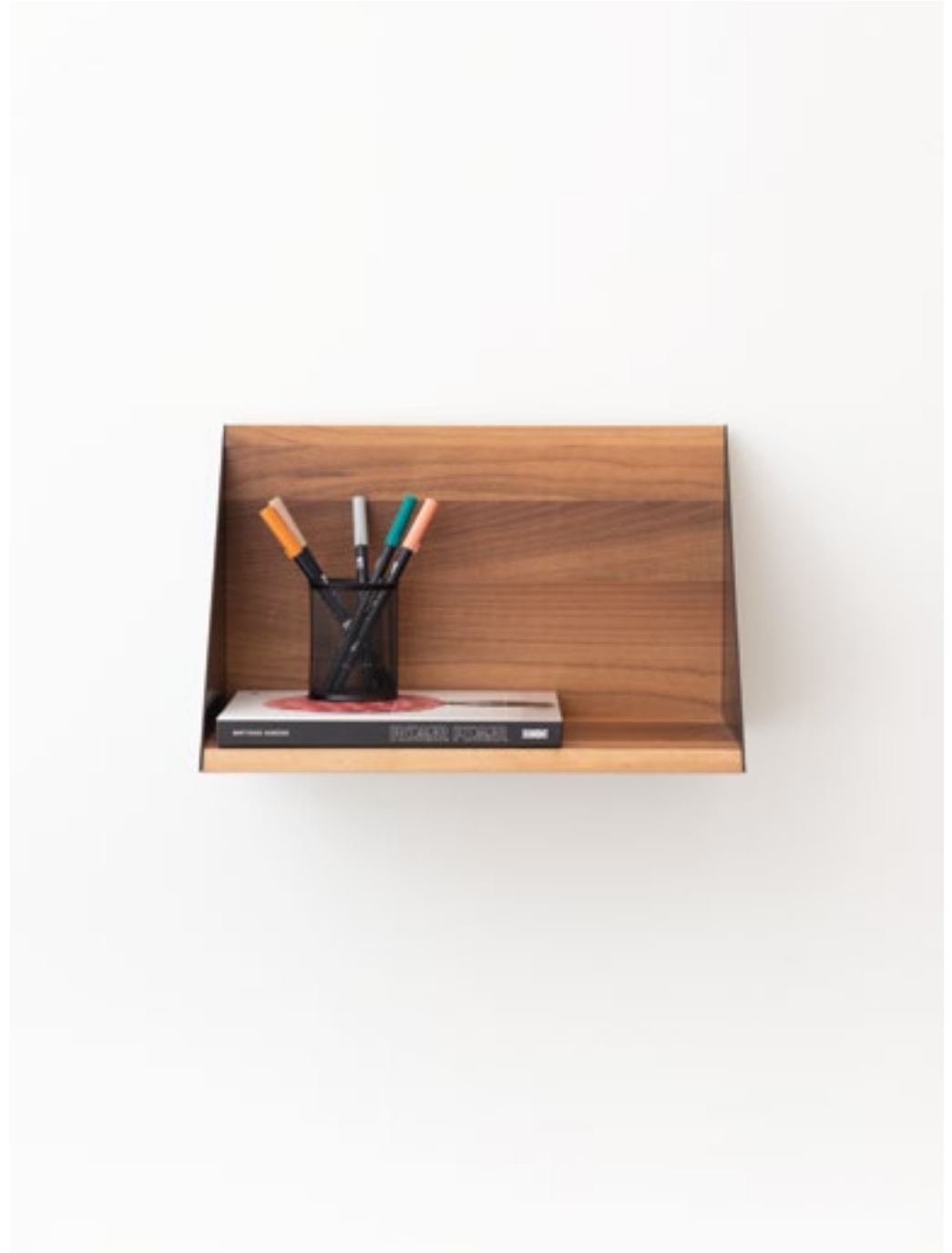
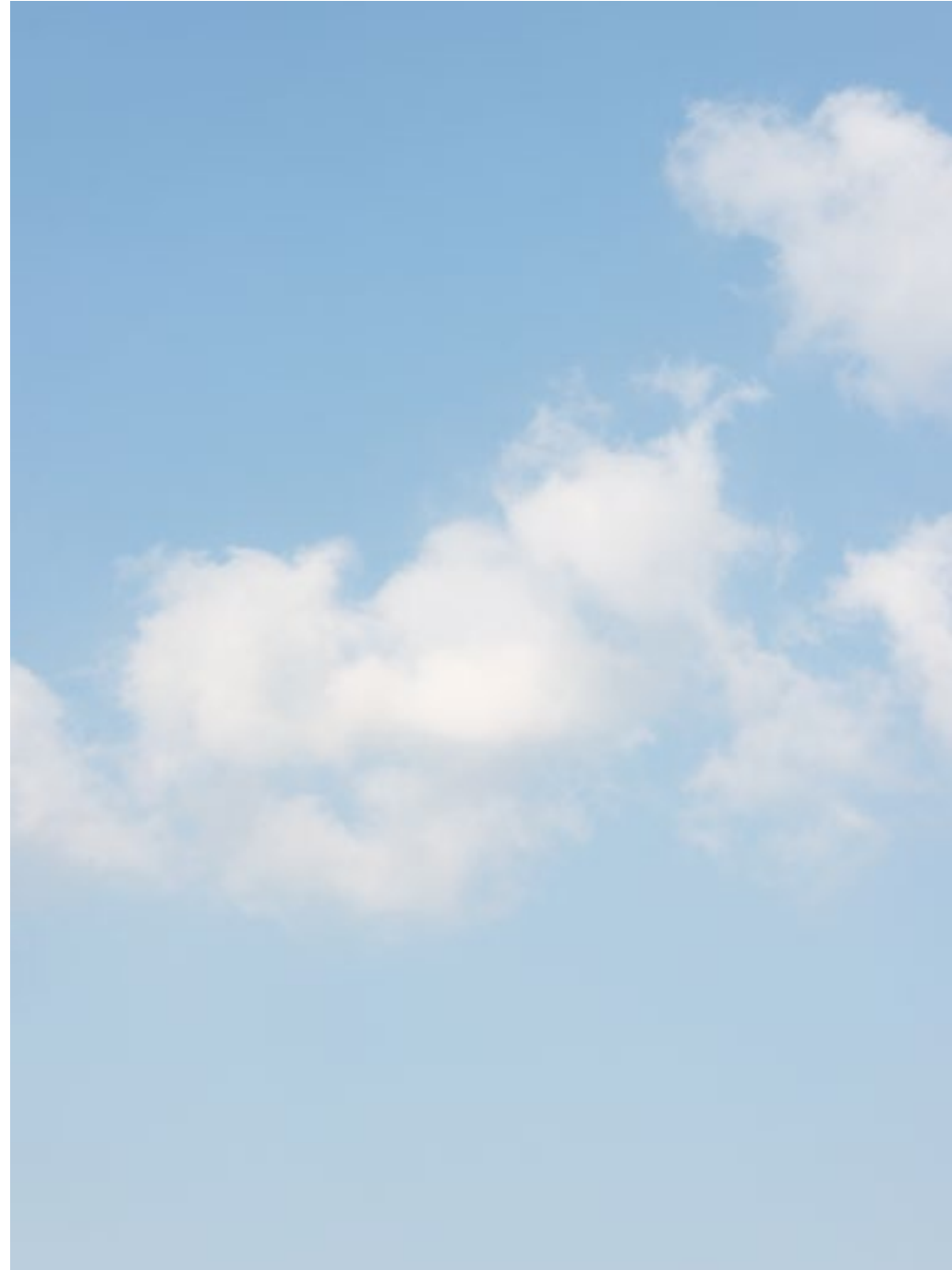



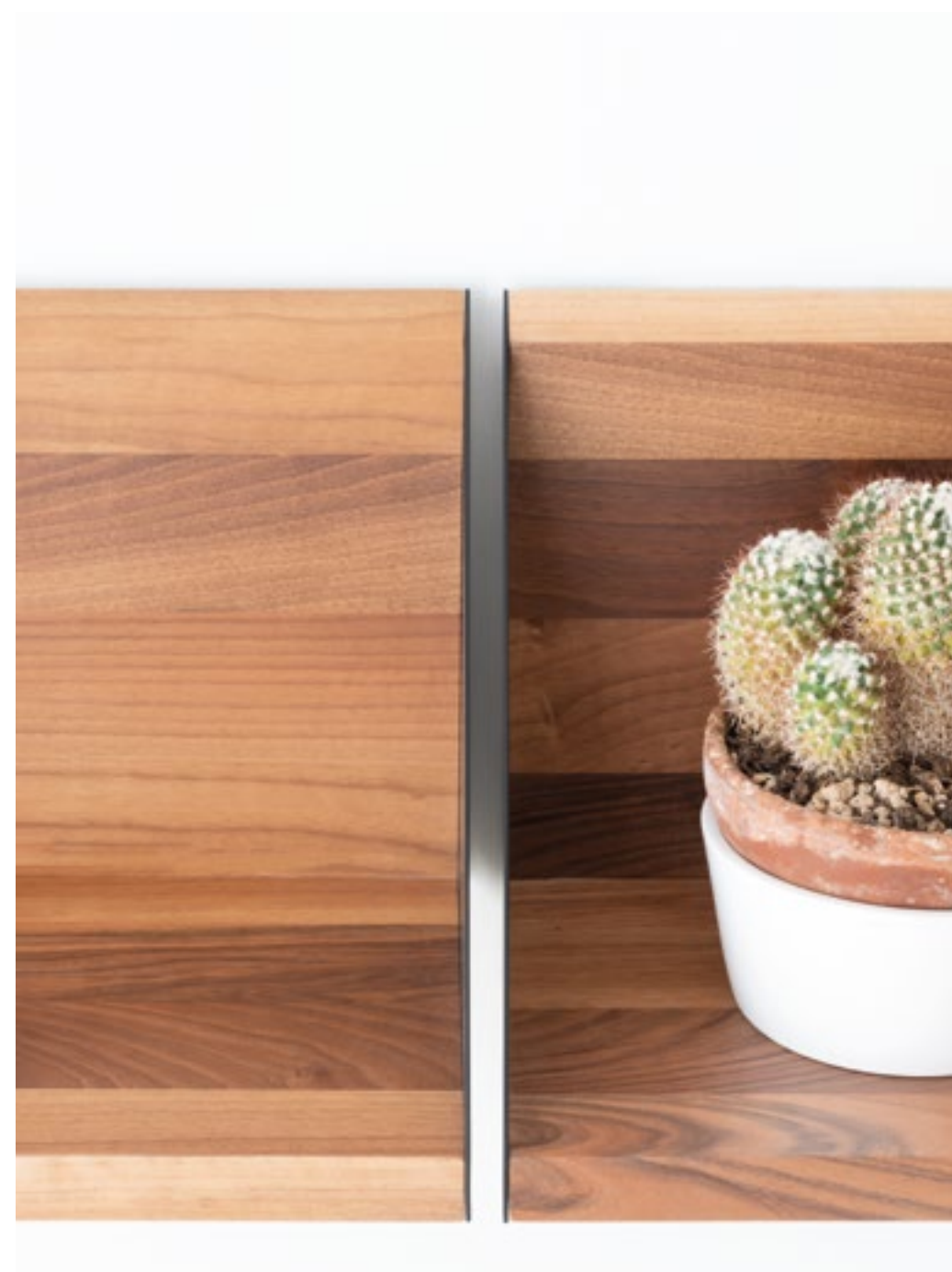



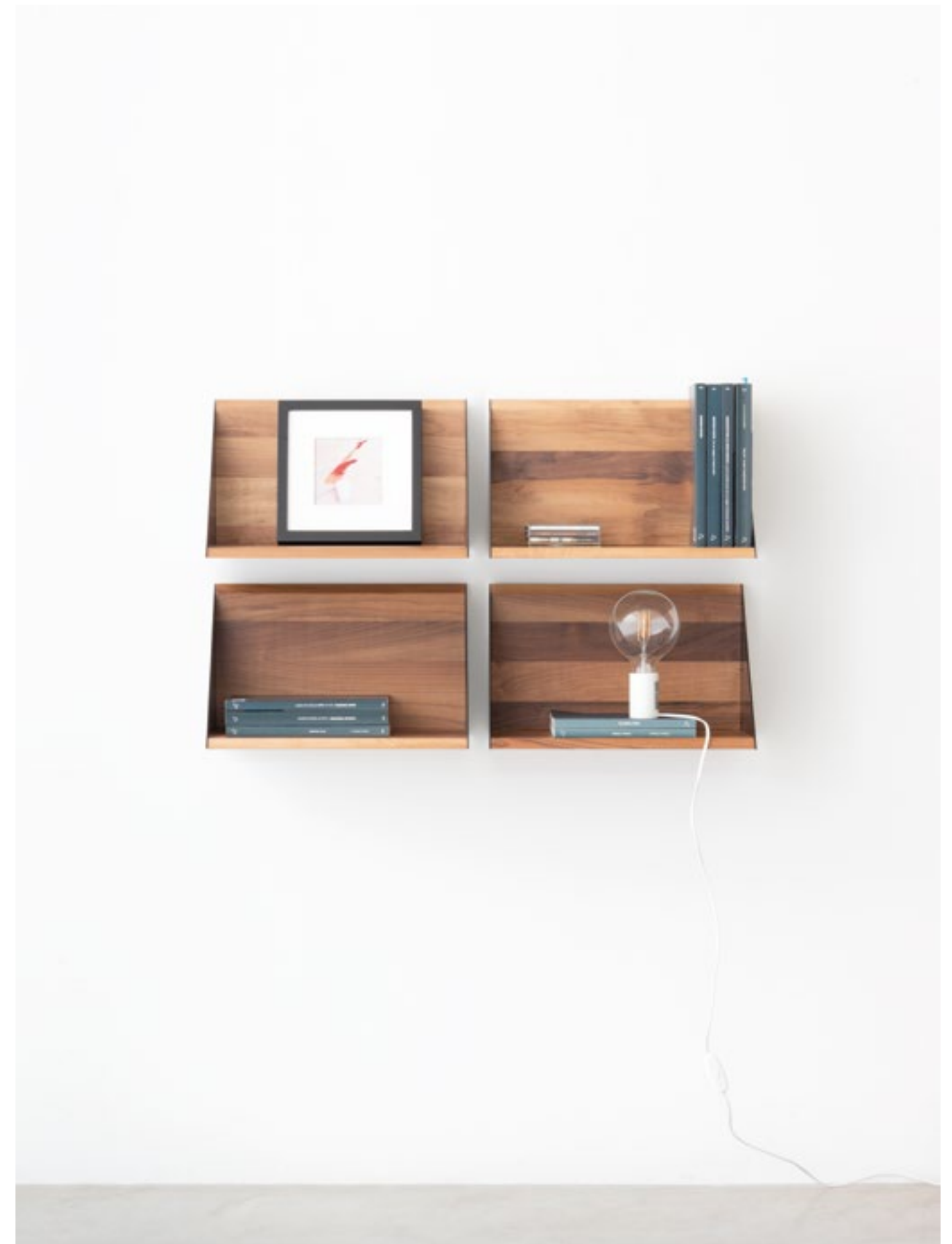

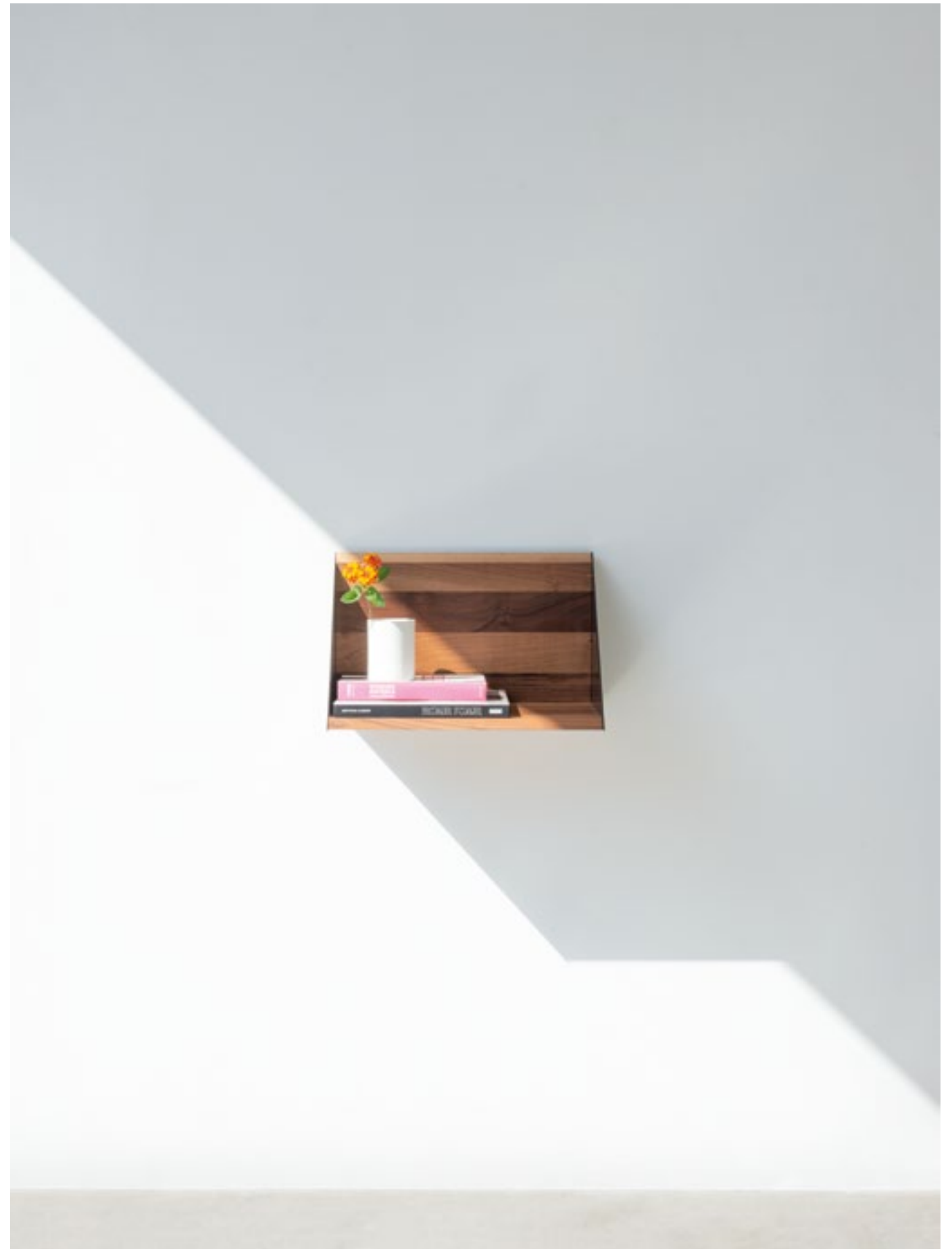

Multiuso

2017

Un blocco rettangolare in noce, ospita nei suoi fori aste in legno dalle molteplici funzioni. Come appendiabiti o piano d'appoggio, come portasalviette o specchio, l'oggetto esprime nei vari ambienti della casa la sua vocazione di multiuso.

A rectangular block in walnut, hosts in its holes wooden rods with multiple functions. As a clothes hanger or table top, as a towel rail or mirror, the object expresses its multi-purpose vocation in the various rooms of the home.

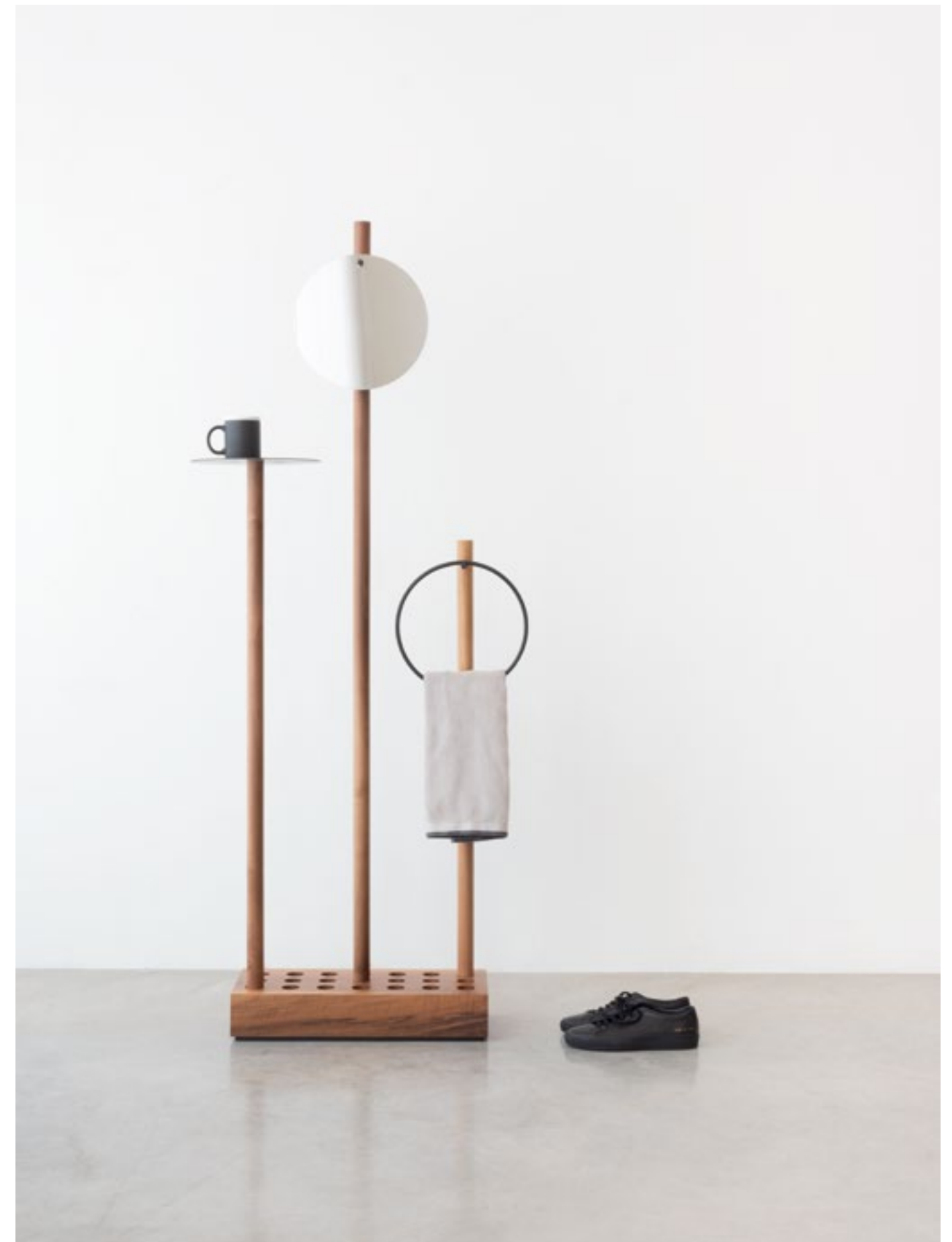



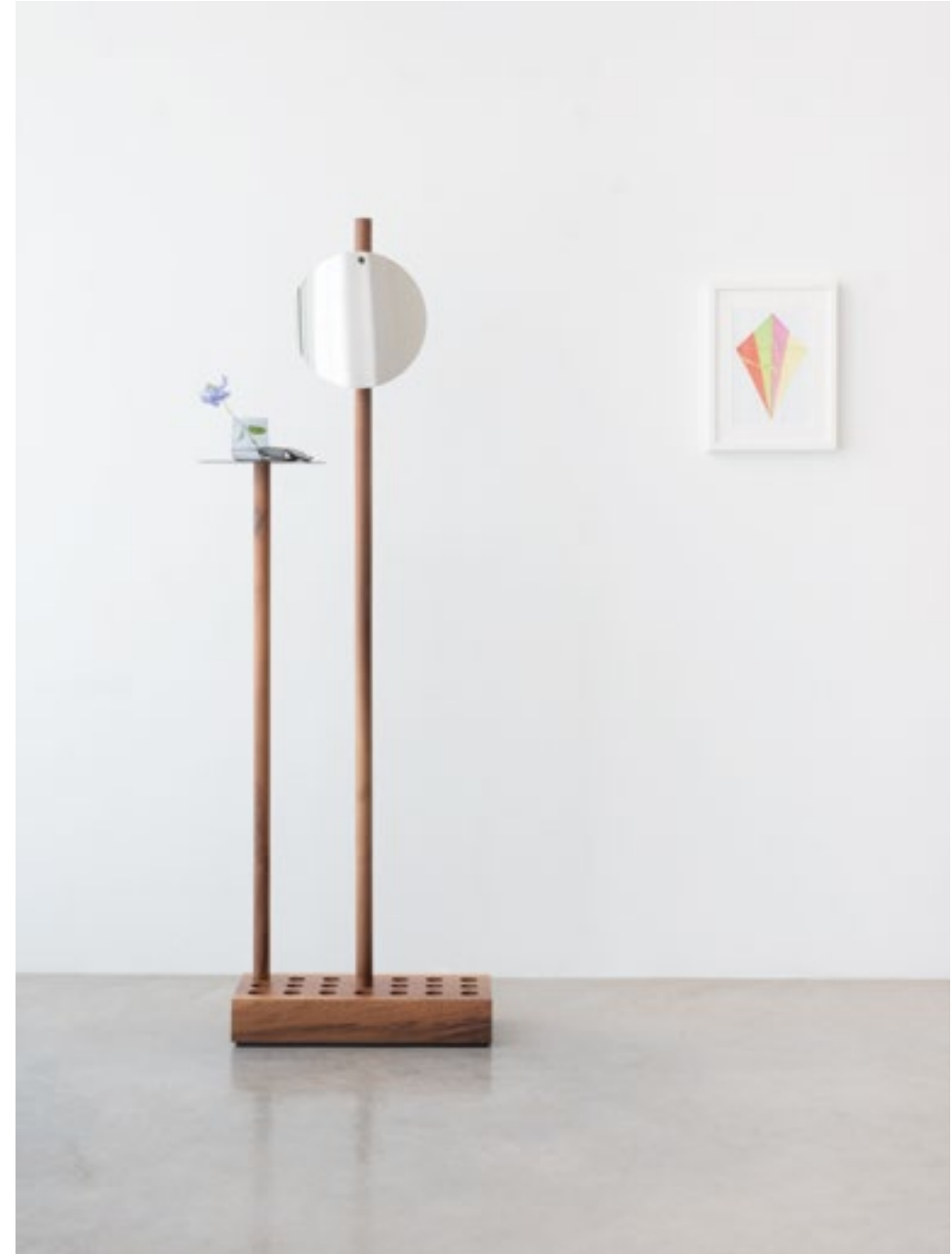

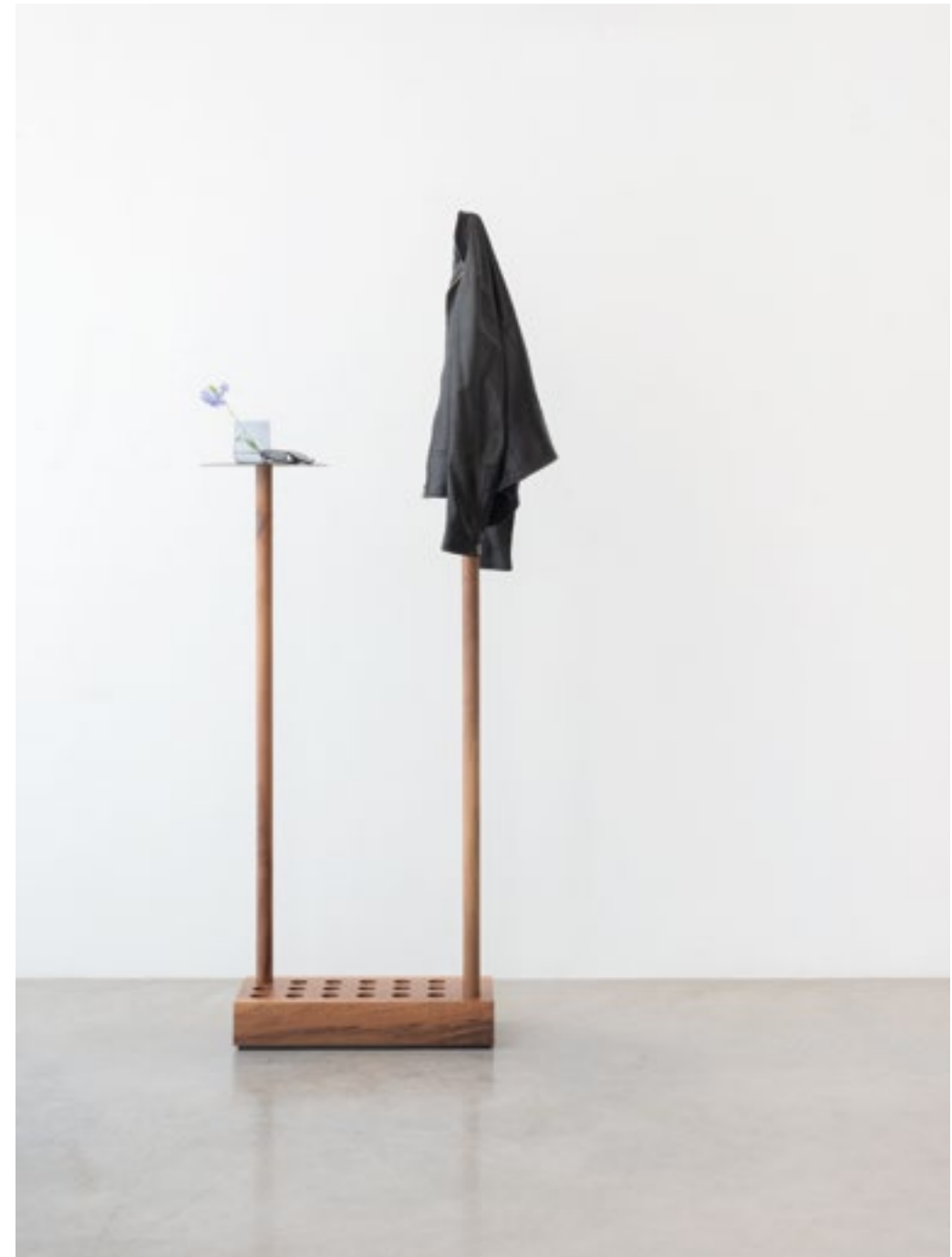









Modulare

2017

Un piano e due fianchi in massello di noce costruiscono un oggetto dalla forma pura. Utilizzati come sedute o tavolini, se sovrapposti i semplici moduli creano composizioni dalle molteplici funzioni. Librerie, contenitori dall'aspetto austero vengono addolciti dalle parti verniciate dei mobili che regalano all'oggetto una leggerezza sempre nuova allo sguardo.

A top with two sides in solid walnut builds an object of pure form. Used as seats or tables, if overlapped the simple modules create compositions with multiple functions. Bookcases, containers with an austere appearance are softened by the painted parts of the furniture that give the object a lightness that is always new to the eye.























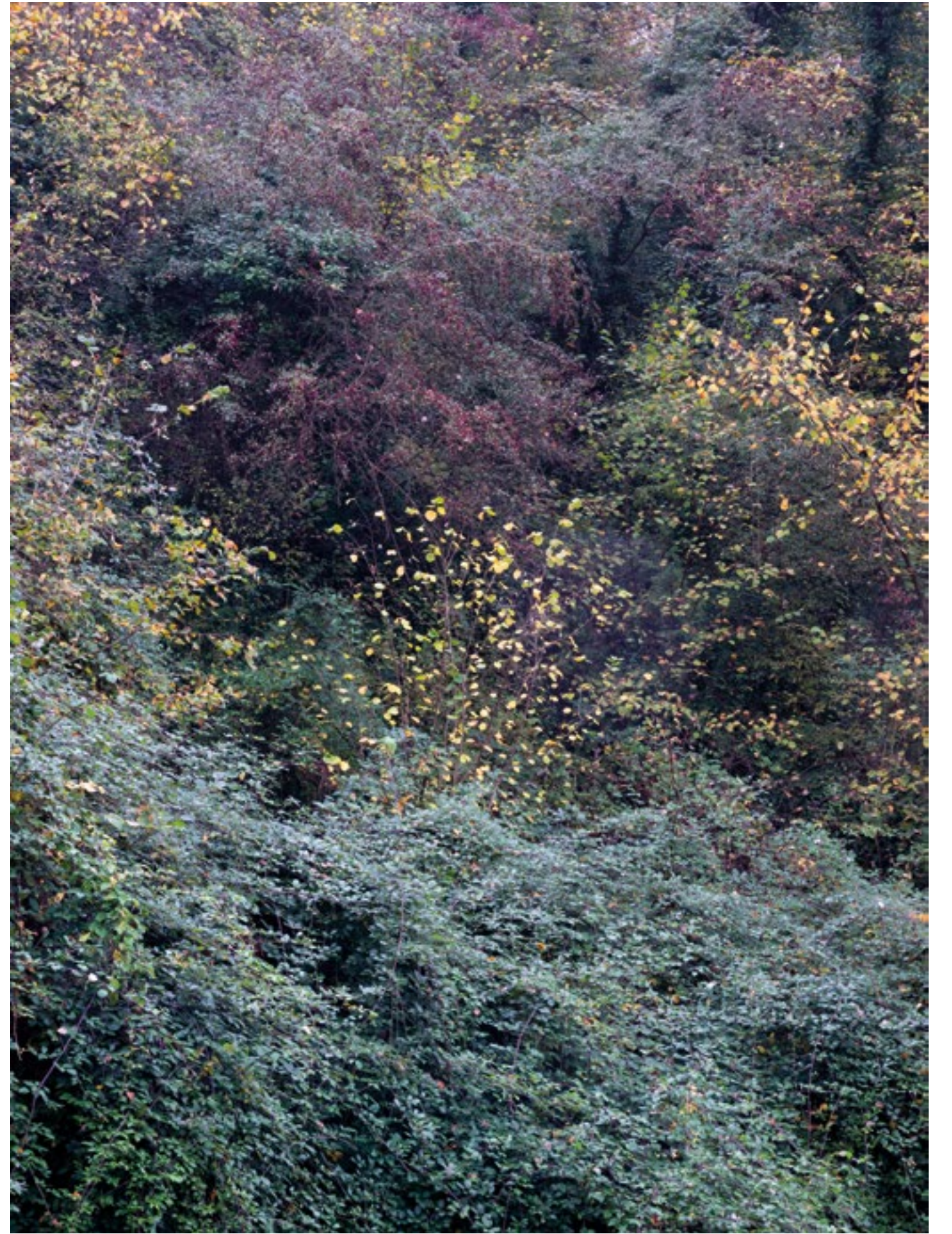

Paravento

2018

Quattro ante rettangolari in legno di noce e lamiera forata schermo- no spazi disegnando suggestioni in chiaroscuro.

Four rectangular doors in walnut and perforated sheet shield spaces drawing light and dark suggestions.

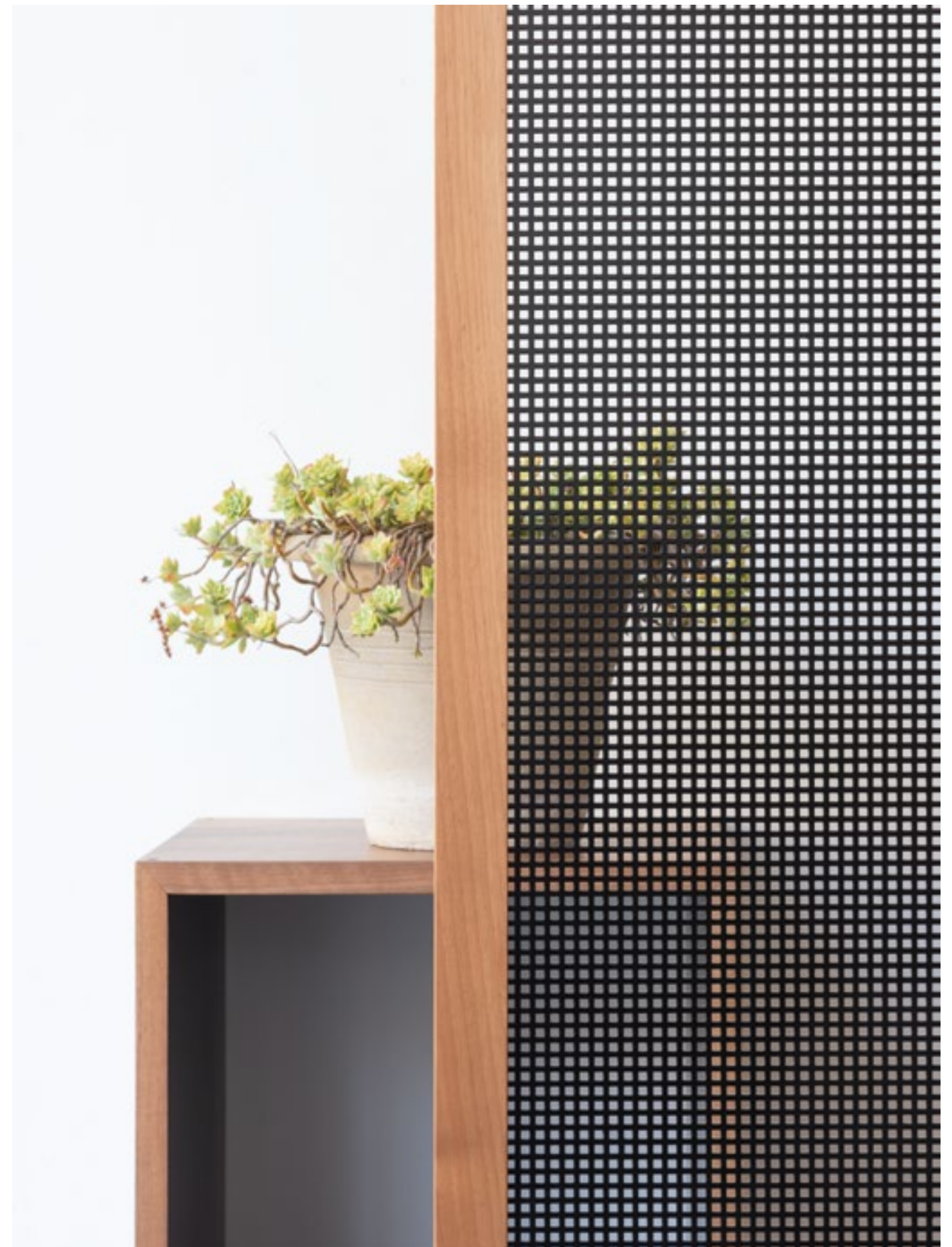











Specchio tondo

2018

Cornici in massello di noce disegnano specchi dalle forme semplici. Un'ampia circonferenza e un proporzionato rettangolo riflettono spazi della vita quotidiana.

Frames in solid walnut design mirrors with simple shapes. A large circumference and a proportioned rectangle reflects spaces of everyday life.





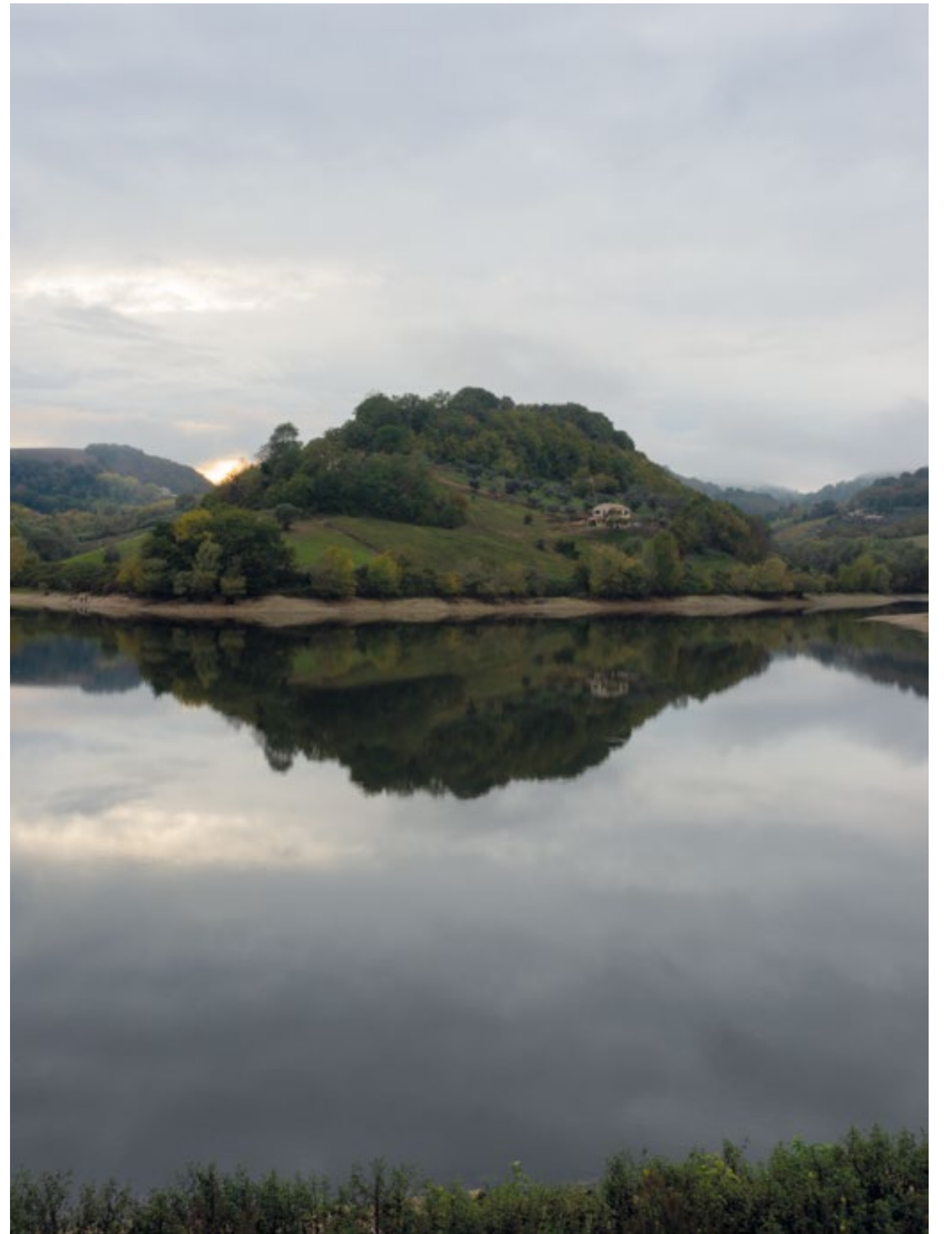

Specchio rettangolare 2018





1 Le finiture e i colori sono rappresentati a titolo indicativo non essendo possibile rendere con la stampa l'effettiva caratteristica dei vari materiali.

2 Il legno massello presenta caratteristiche morfologiche che possono venire impropriamente interpretate come difetti. In realtà si tratta di qualità che lo contraddistinguono come un materiale unico e pregiato, differenziandolo dai materiali di minor valore che spesso vengono impiegati.

In generale è importante sapere che nodi, piccole crepe, fessurazioni e lievi differenze di tonalità sono pregi che contraddistinguono i manufatti in massello e ne confermano l'autenticità. I nodi sono elementi naturali, presenti nella maggior parte delle specie di legno. Le fessurazioni, piccole crepe e lievi difformità sono dovute tanto all'essiccazione naturale del legno quanto a variazioni di umidità nell'aria e sbalzi di temperatura. L'unicità è una caratteristica di ogni elemento naturale: in natura non possono esistere due piante esattamente identiche.

Per questo, nonostante l'elevato standard qualitativo delle finiture, è impossibile ottenere superfici perfettamente omogenee ed esattamente uguali tra loro: lievi differenze di tonalità confermano l'autenticità del legno massello proveniente da tronchi diversi.

3 Il legno è per sua natura sensibile alla luce, con il tempo tende a scurire, si consiglia di non lasciare oggetti in modo permanente sulla superficie del legno per evitare cambiamenti di colore.

1 Colours and finishes are for reference purposes only, since using digital printing it is not possible to preserve the inherent features of the different materials.

2 Solid wood has morphological characteristics that may be improperly seen and considered as defects, but, instead, they mark its unique character, distinguishing it from other materials.

In general it is very important to know that knots, cracks, grain and colour variations are part of the unique charm and beauty and genuineness of wood. Knots are a natural characteristic found in most wood species. Small cracks, grain and colour variations are due both to the natural wood drying and to moisture variations in the air together with temperature leaps. Uniqueness is one of the fundamental features of any natural product: there is absolutely no possibility of having two absolutely identical trees. This makes it impossible to obtain, despite our high quality standards, homogeneous and identical surfaces. Slight colour differences are, however, the confirmation of the genuineness of solid wood, which differs from batch to batch.

3 As it is responsive to light, it is the general nature of wood to darken slightly over time. We recommend not to leave objects permanently on any wood surface to prevent unaesthetic colour spots.

Legno:
Noce nazionale

Altri materiali:
Ferro verniciato,
Vetro specchio,
Acciaio cromato
super mirror

Tessuti:
Pelle nera

Vernici su ferro:
Nero opaco
RAL 9005

Wood:
European walnut

Materials:
Laquered iron,
Glass mirror,
High gloss
chromed steel

Fabrics:
Black leather

Paint on iron:
Matt black
RAL 9005

La ditta si riserva di apportare, senza alcun preavviso, eventuali modifiche ritenute necessarie per un miglioramento tecnico e produttivo.

The company reserves the right to modify the products for their technical and productive improvement without prior notice.

Tavolo rettangolare 2017

19—32

Vista dall'alto
/From the top

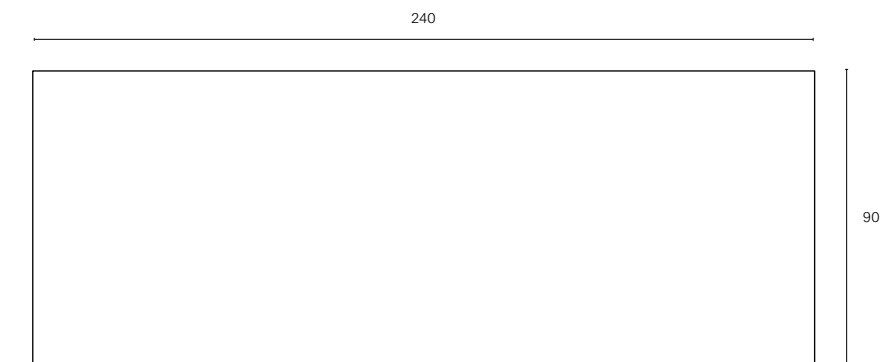

Vista frontale
/Front view

Vista laterale
/Side view

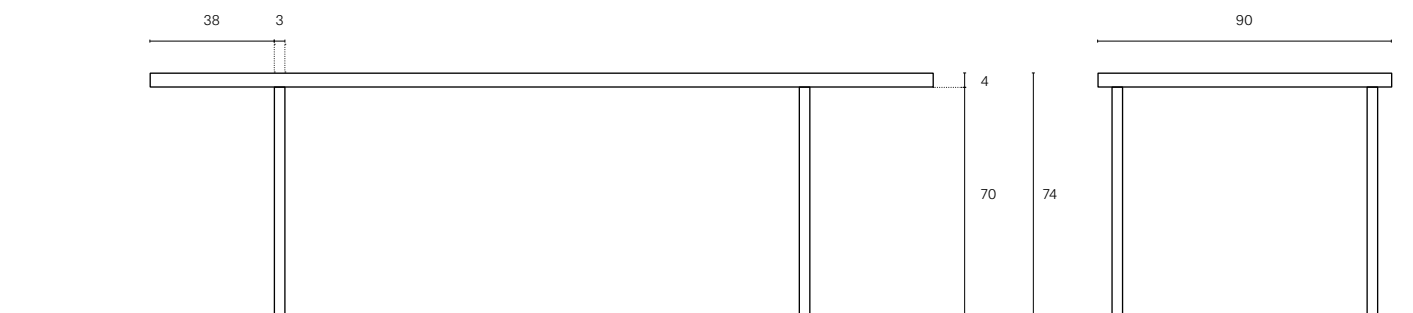

Dimensioni
/Size [cm]

Materiali
/Materials

Designer, Anno
/Designer, Year

L 240 P 90 H 74

Noce nazionale, Ferro verniciato
/European walnut, Laquered iron

Roberto Cicchinè,
2017

Tavolo quadrato

2017

33—41

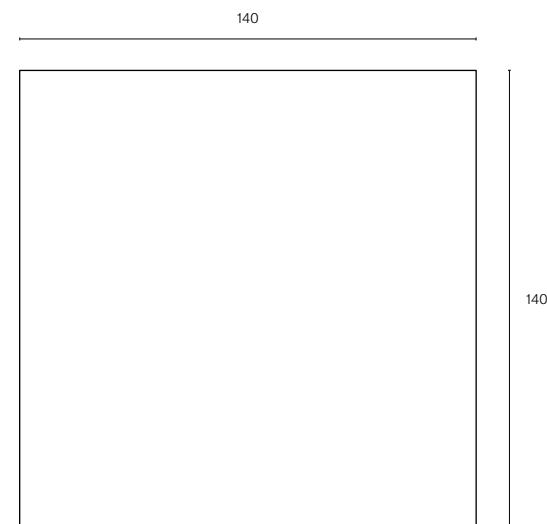
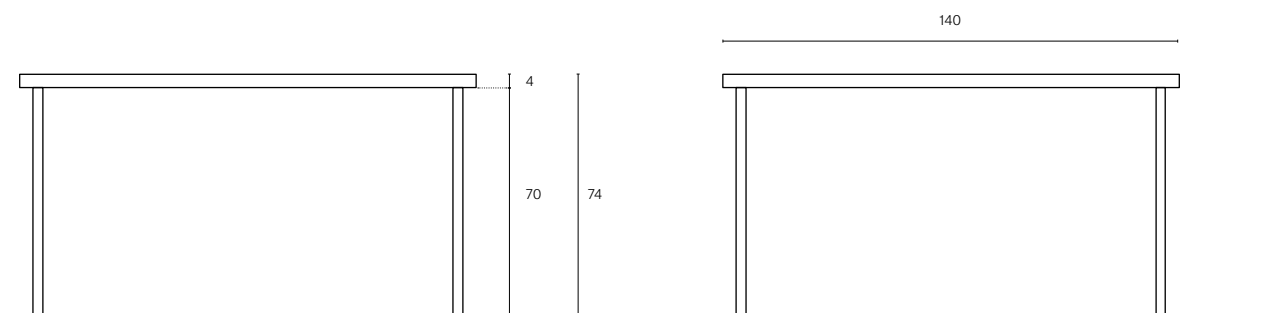
Vista dall'alto
/From the topVista frontale
/Front viewVista laterale
/Side viewDimensioni
/Size [cm]Materiali
/MaterialsDesigner, Anno
/Designer, Year

L 140 P 140 H 74

Noce nazionale, Ferro verniciato
/European walnut, Laquered ironRoberto Cicchinè,
2017

Credenza

2017

44—55

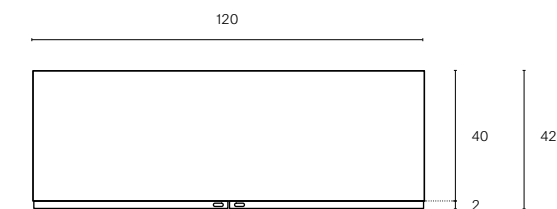
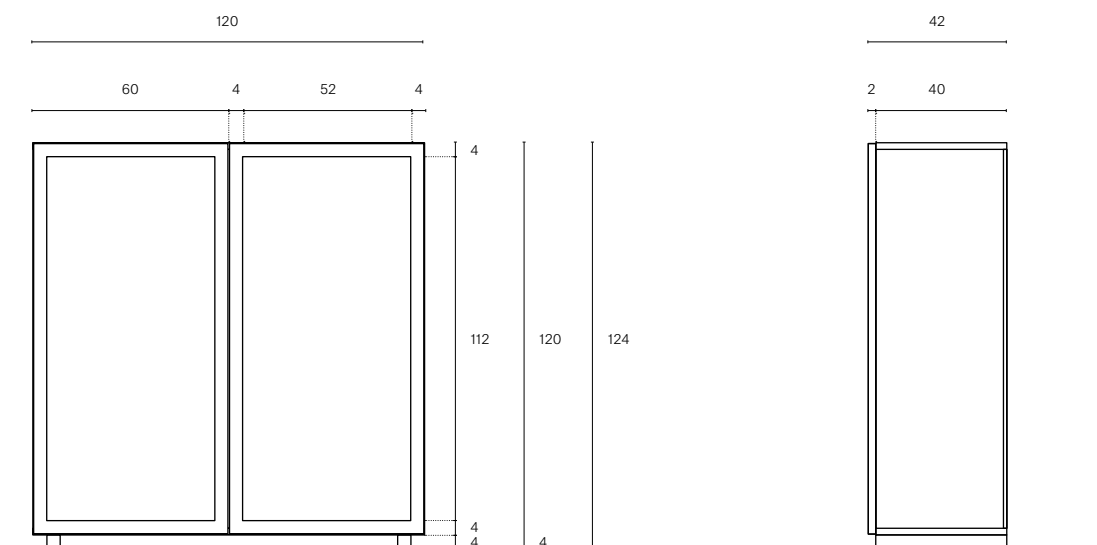
Vista dall'alto
/From the topVista frontale
/Front viewVista laterale
/Side viewDimensioni
/Size [cm]Materiali
/MaterialsDesigner, Anno
/Designer, Year

L 120 P 42 H 124

Noce nazionale, Ferro verniciato
/European walnut, Laquered ironRoberto Cicchinè,
2017

Credenza bassa

2017

58—67

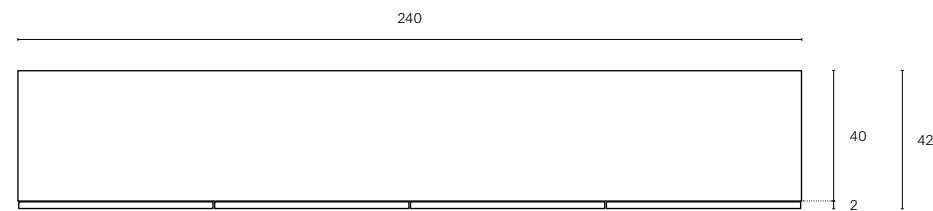
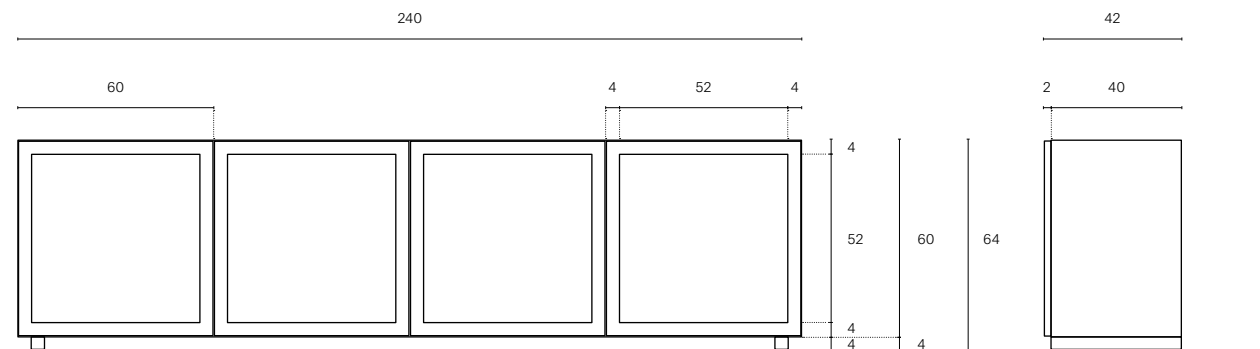
Vista dall'alto
/From the topVista frontale
/Front viewVista laterale
/Side viewDimensioni
/Size [cm]Materiali
/MaterialsDesigner, Anno
/Designer, Year

L 240 P 42 H 64

Noce nazionale, Ferro verniciato
/European walnut, Laquered ironRoberto Cicchinè,
2017

Mensola

2017

70—83

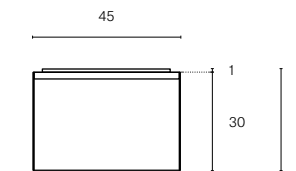
Vista dall'alto
/From the topVista frontale
/Front viewVista laterale
/Side viewDimensioni
/Size [cm]Materiali
/MaterialsDesigner, Anno
/Designer, Year

L 45 P 28 H 28

Noce nazionale, Ferro verniciato
/European walnut, Laquered ironRoberto Cicchinè,
2017

Multiuso

2017

84–95

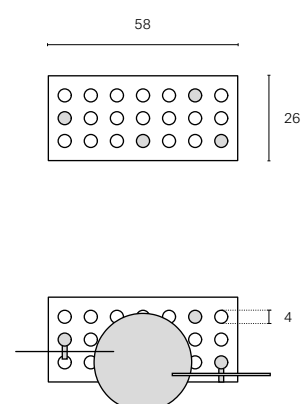
Vista dall'alto
/From the topAccessori a scelta per la composizione
/Accessories at your choice for the composition

- 1 Bastone alto con accessorio specchio
/High stick with mirror accessory
- 2 Bastone medio con vassoio
/Medium stick with tray
- 3 Bastone alto
/High stick
- 4 Bastone basso con portasalviette
/Low stick with towel rail

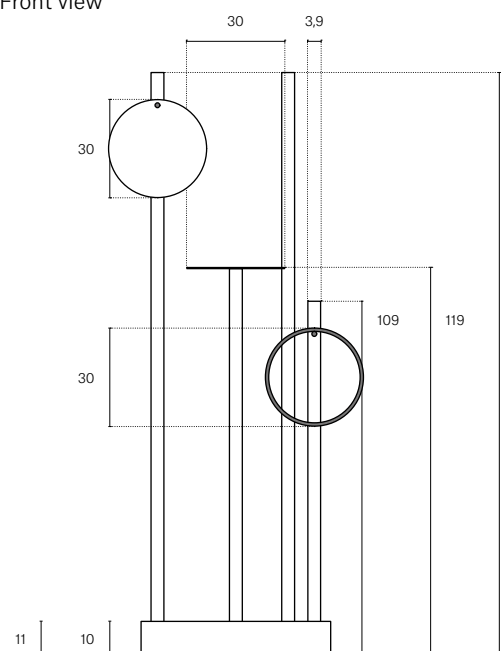
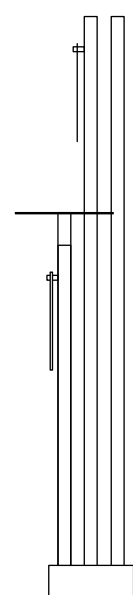
Vista frontale
/Front viewVista laterale
/Side view

1 2 3 4

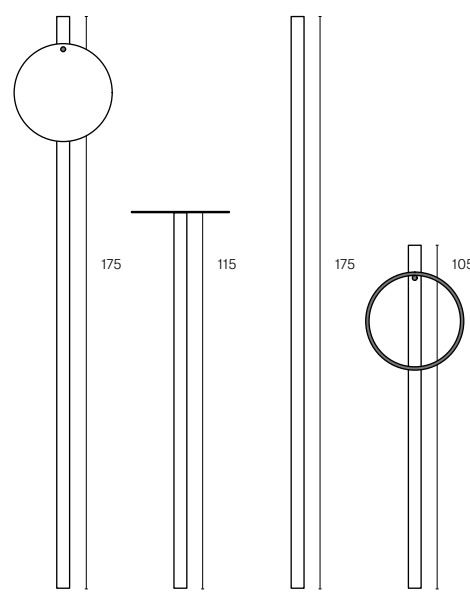
Dimensioni basament
/Basement size [cm]

L 58 P 26 H 11

Materiali
/Materials

Noce nazionale, Ferro verniciato,
Acciaio cromato super mirror
(accessorio)/European walnut,
Laquered iron, High gloss
chromed steel (for the accessory)

Designer, Anno
/Designer, Year

Maria Francesca
Novelli, 2017

Modulare

2017

100–121

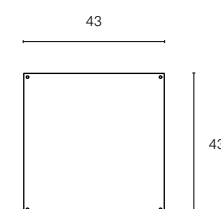
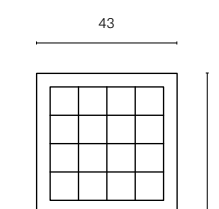
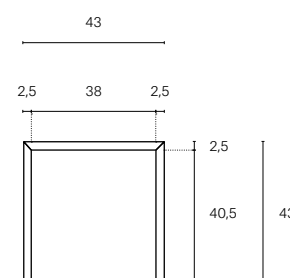
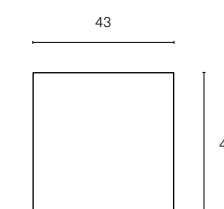
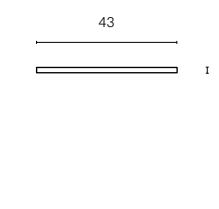
Vista dall'alto
/From the topAccessorio cuscino visto
dall'alto/Optional pillow from
the top*Vista frontale
/Front viewVista laterale
/Side viewAccessorio cuscino, vista
frontale /Front view of the
optional pillow*Dimensioni
/Size [cm]

L 43 P 43 H 43

Materiali
/Materials

Noce nazionale, Ferro verniciato,
Pelle nera (accessorio)/European
walnut, Laquered iron, Black
leather (for the accessory)

Designer, Anno
/Designer, Year

Roberto Cicchinè,
2017

*Opzionale su richiesta
/Optional on request

Paravento

2018

124—133

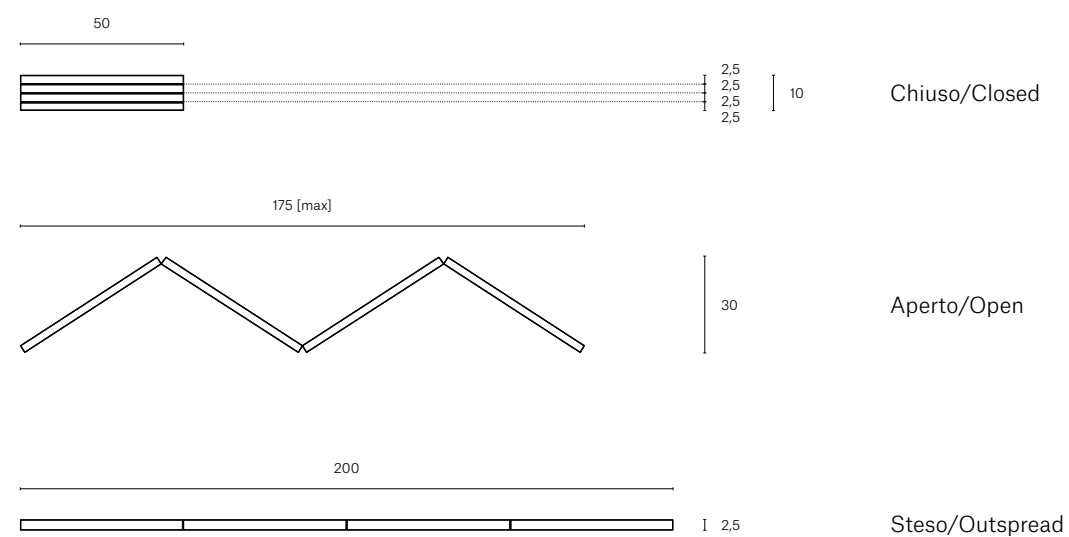
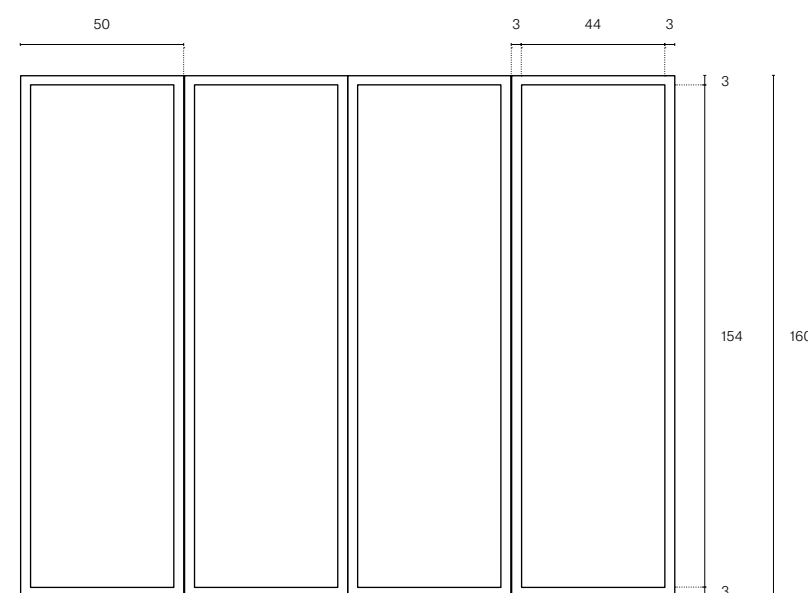
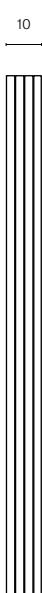
Vista dall'alto
/From the topVista frontale
/Front viewVista laterale
/Side viewDimensioni aperto
/Open Size [cm]

L 175 P 30 H 160

Materiali
/MaterialsNoce nazionale, Ferro verniciato
/European walnut, Laquered ironDesigner, Anno
/Designer, YearRoberto Cicchinè,
2018

Specchio tondo

2018

136—139

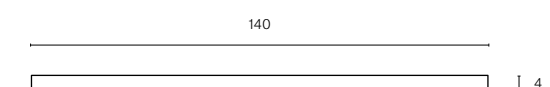
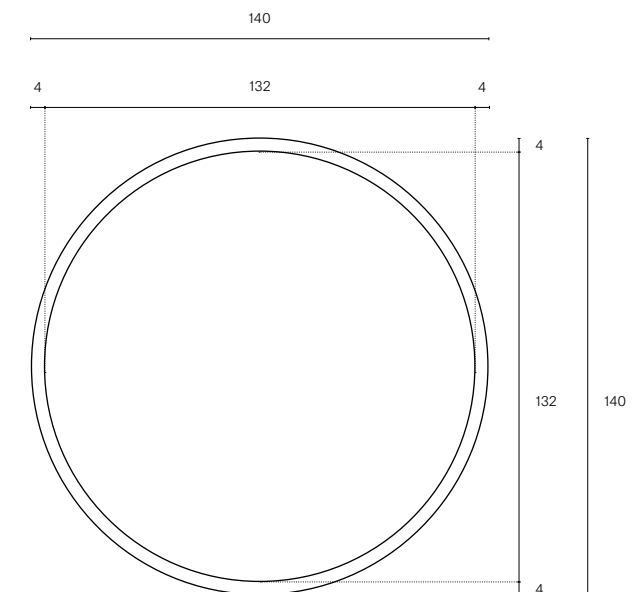
Vista dall'alto
/From the topVista frontale
/Front viewVista laterale
/Side viewDimensioni
/Size [cm]

Ø 140 P 4

Materiali
/MaterialsNoce nazionale, Specchio vetro
/European walnut, Glass mirrorDesigner, Anno
/Designer, YearRoberto Cicchinè,
2018

Specchio rettangolare 2018

142—144

Vista dall'alto
/From the top

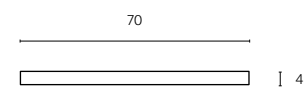

Vista frontale
/Front view

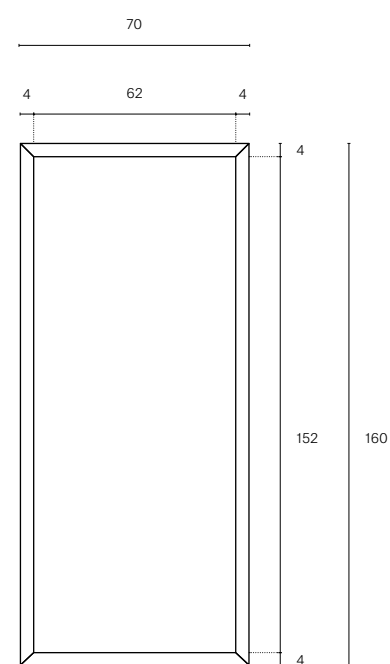

Vista laterale
/Side view



Dimensioni
/Size [cm]

L 70 P 4 H 160

Materiali
/Materials

Noce nazionale, Specchio vetro
/European walnut, Glass mirror

Designer, Anno
/Designer, Year

Roberto Cicchinè,
2018

Unopervolta

Via Santa Maria dell'Arco, snc
64023 Mosciano Sant'Angelo TE
ITALIA

T. +39 085 8072135
E. info@unopervolta.it
W. www.unopervolta.it

P.I. 02068690672

Direzione artistica dell'azienda,
testi e fotografie/Company Art
Direction, texts and photos
Roberto Cicchinè

Design prodotti/Product design
Roberto Cicchinè,
Maria Francesca Novelli

Progetto grafico/Graphic design
CH RO MO (Chris Rocchegiani,
Roberto Montani)

Traduzione e proofreading
/Translation and proofreading
Paola Lucidi

Post produzione fotografica
/Photo post-production
Stefano Baldassari

Stampato a/Printed in
Marzo/March 2020

Stampato in offset da/Offset
printing by Grafiche Martintype
Industria Arti Grafiche e Digitali
Strada Bonifica Tronto Km 1.800
64010 Colonnella TE

Carta copertina/Cover paper
Fedrigoni Materica Pitch gr. 360

Carte blocco libro/Inlay papers
Arctic Paper Munken Lynx gr. 100
Fedrigoni Arcoprint 1.7 gr. 90

Caratteri in uso/Type in use
Atlas Grotesk, Commercial Type

Grazie a/Thanks to
Design? Studio Associato, Radice
Quadrata, Marco Ripa, Mercatino
Usato San Benedetto del Tronto

Tutti i diritti riservati ©
/All rights reserved ©

Tavolo rettangolare	2017
Tavolo quadrato	2017
Credenza alta	2017
Credenza bassa	2017
Mensola	2017
Multiuso	2017
Modulare	2017
Paravento	2018
Specchio tondo	2018
Specchio rettangolare	2018