

We select the best raw materials for fine parquet that offer true perceptive harmonies.

Our History	p. 4
The Essenze method	p. 5
Surfaces: Structure	p. 6
Essence & materials	p. 8
Our products	

• Parquet & Chevron	p. 14
• Modular parquet & Geometric figures	p. 24
• Essenze Tiles	p. 40
• Customized parquet	p. 74

Series

• Venus	p. 82
• Gea	p. 91
• Kronos	p. 96

Surfaces:

Treatments	p. 106
Finishes	p. 107

Certifications	p. 109
----------------	--------

Recommandation for the maintenance of parquet	p. 110
---	--------

Products for the treatment of parquet	p. 111
---------------------------------------	--------

General Sales Conditions	p. 112
--------------------------	--------

Our History

La Brenta was born in 2004 at the foot of the Euganean Hills, not far from Padua. A small artisan company that since the beginning has committed to the creation of refined inlaid wood surfaces. In 2009 we introduced resin inlays into the manufacturing, and other materials to follow - such as metal, marble, ceramic and leather. Finally, in 2010, the launch of the new "Essenze" brand.



The Essence Method

The Essence method places at its centre the person and its vision or project. We want to give everyone the opportunity to realize it, finding the right balance between the idea and its actual realization.

For this reason, our job begins with the listening of our customers, in order to define their necessities and ambitions.

Our designers dialogue with the clients and present them the solution that better fit their vision.





Surfaces

The structure of our floors

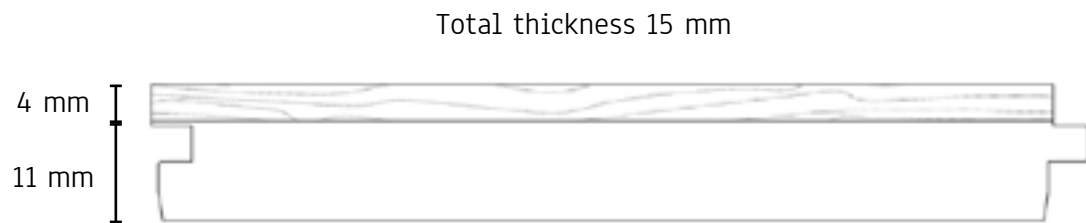

Tongue with profile to ease the connection

Essences & Materials

We have employed more than 30 types of wood in our projects, thanks to solid channels that we have developed during the years. We can satisfy any request and if you don't find in our pricelist the essence you are looking for, send us your request and we will provide a quotation *ad hoc* for you.



Acero



Afromosia



Castagno



Doussie



Faggio

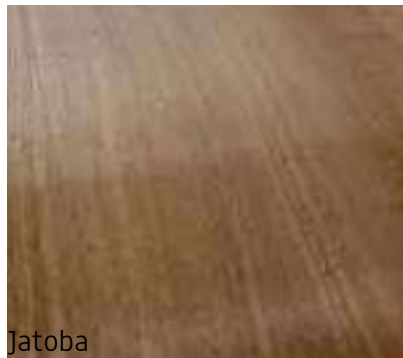

Jatoba

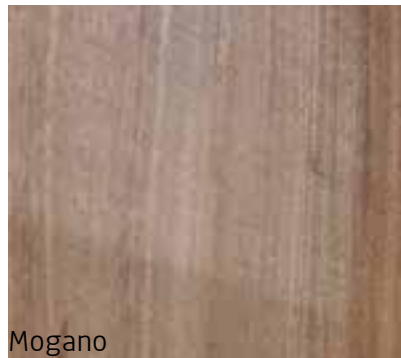

Mogano



Mutenye

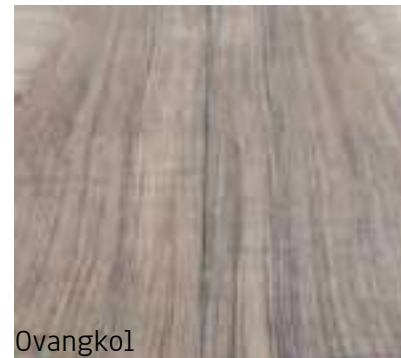

Ovangkol



Padouk

E molti altri..



Essence & Materials

Nacre



We have a wide range of coloured nacres available. Upon request we can also offer bioresins. Nacre is a very versatile material that gives light and spirit to your floor.

Only available finish: shiny

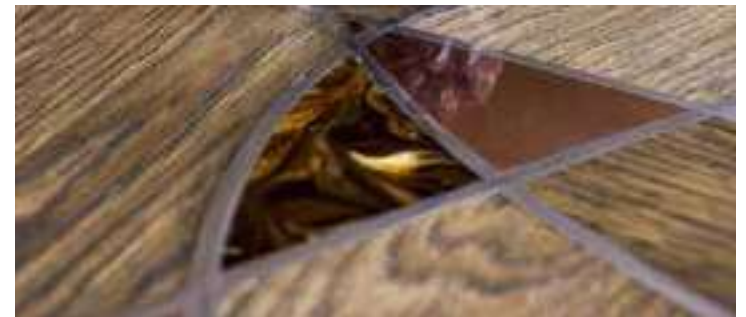

Marble



Our proposals:

- White Carrara
- Vicenza's stone
- Purple Calacatta
- Verde Alpi
- Serena Stone
- Black Marquina
- Venecian Terrazzo
- Emperador Dark
- Fior di Pesco Carnico
- Black Saint Lorant
- Volakas Ariston

Available finishes: shiny; brushed; sandblasted; sanded.

You can choose whatever marble you like to combine it with our floors. We can provide either the element entirely made of marble (all thickness), or the element of marble glued on MDF support with groove (to ease the laying process).



Semi-precious Stone



We can also install semi-precious stones in our floors. The result is a unique inlaid floor with a great value.

Among the semi-precious stones you can choose you can find:

- Tiger Eye
- Sodalite
- Fossil Wood
- Malachite



Metal



Our proposals:

- Bronze
- Brass
- Copper
- Steel
- Aluminium
- Iron

Finish

Satin

Satin; Antiqued

Satin

Satin

Satin; Semi-shiny; Sandblasted; Antiqued

Antiqued

Our research is oriented not only to the raw material, but also to the different surface treatments that can be applied. In addition to the traditional wood finishes, we have studied various solutions for the treatments of metals applied to floors: from oxidation, to the antique, sanded or polished effects, according to the client's preference.



Leather



If you are looking for a very exclusive floor, ask for our leather inlays.

A delicate product indeed, but it can also be durable if you choose high quality leather and if you use the right products for the care of the floor.

According to the project it will be possible to cover with leather elements having different shapes.

We use two systems for the application of the leather: plane (side picture) or curved (right picture below).



Our Parquet

You can dress the entire surface of your home with our floors. Therefore, the basic ingredient cannot be missing: the plank. The parquet has always been expression of elegance and warmth. Discover our selected proposal of floors with mixed or fixed lengths.



Herringbone & Chevron

For an elegant and trendy solution, we offer a wide choice of geometries. The refinement of herringbones and chevrons blend in with any type of environment. Find out our offer of 90° herringbone and the selection of our 45° chevron.

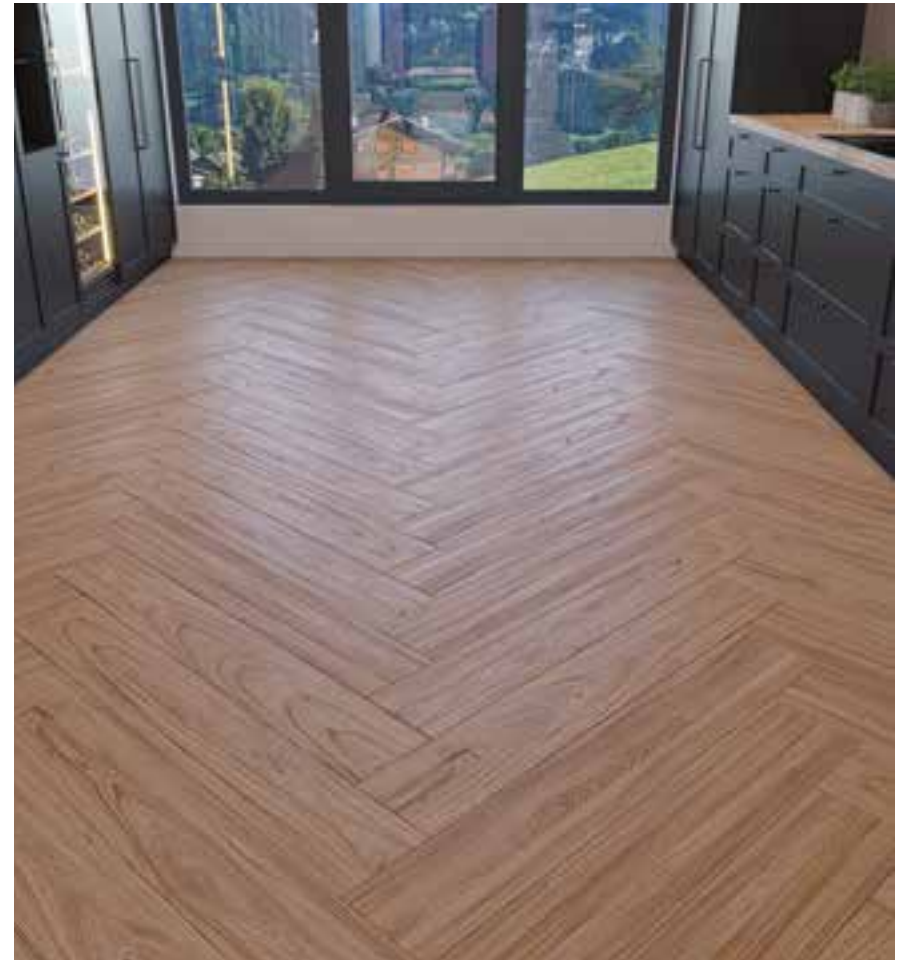



Selection - Oak

Superior

Streight and flamed grain in variable proportions; Possible presence of partridge eyes of healthy knots up to 5 mm in diameter, but with slight chromatic variations.



Prestige

Streight and flamed grain in variable proportions with healthy or properly grouted knots up to 15 mm in diameter. Possible presence of sapwood and chromatic variations.



Comfort

Streight and flamed grain in variable proportions with healthy or properly grouted knots. Possible presence of cracks (grouted or not), sapwood and chromatic variations.



Selection - Elm

Unique

Streight and flamed grain in variable proportions.
Possible presence of knots (properly plastered).
Typical variations of colours or shades.



Selection - Ash

Unique

Streight and flamed grain in variable proportions.
Possible presence of knots (properly plastered).
Typical variations of colours or shades.



Selection - European Walnut

Superior

Structure of wood and variations of the colour typical of this type of wood. Reduced presence of little plastered knots.



Comfort

Structure of wood and variations of the colour typical of this type of wood. Presence of plastered knots (commonly accepted).



Selection - American Walnut

Superior

Structure of wood and variations of the colour typical of this type of wood. Reduced presence of little plastered knots.



Comfort

Structure of wood and variations of the colour typical of this type of wood. Presence of plastered knots (commonly accepted).



Examples of laying

Staggered joints (mixed lengths)

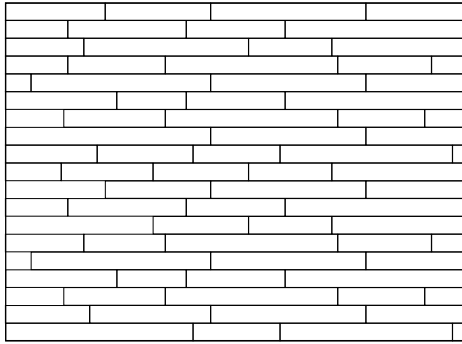

Formwork laying (regular lengths)

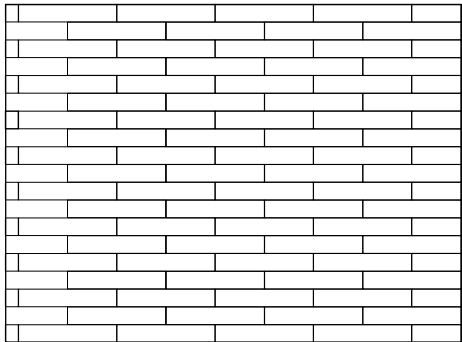

Herringbone 90°

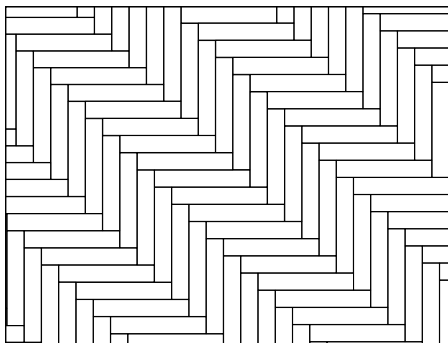

Mixed laying (mixed lengths and widths)

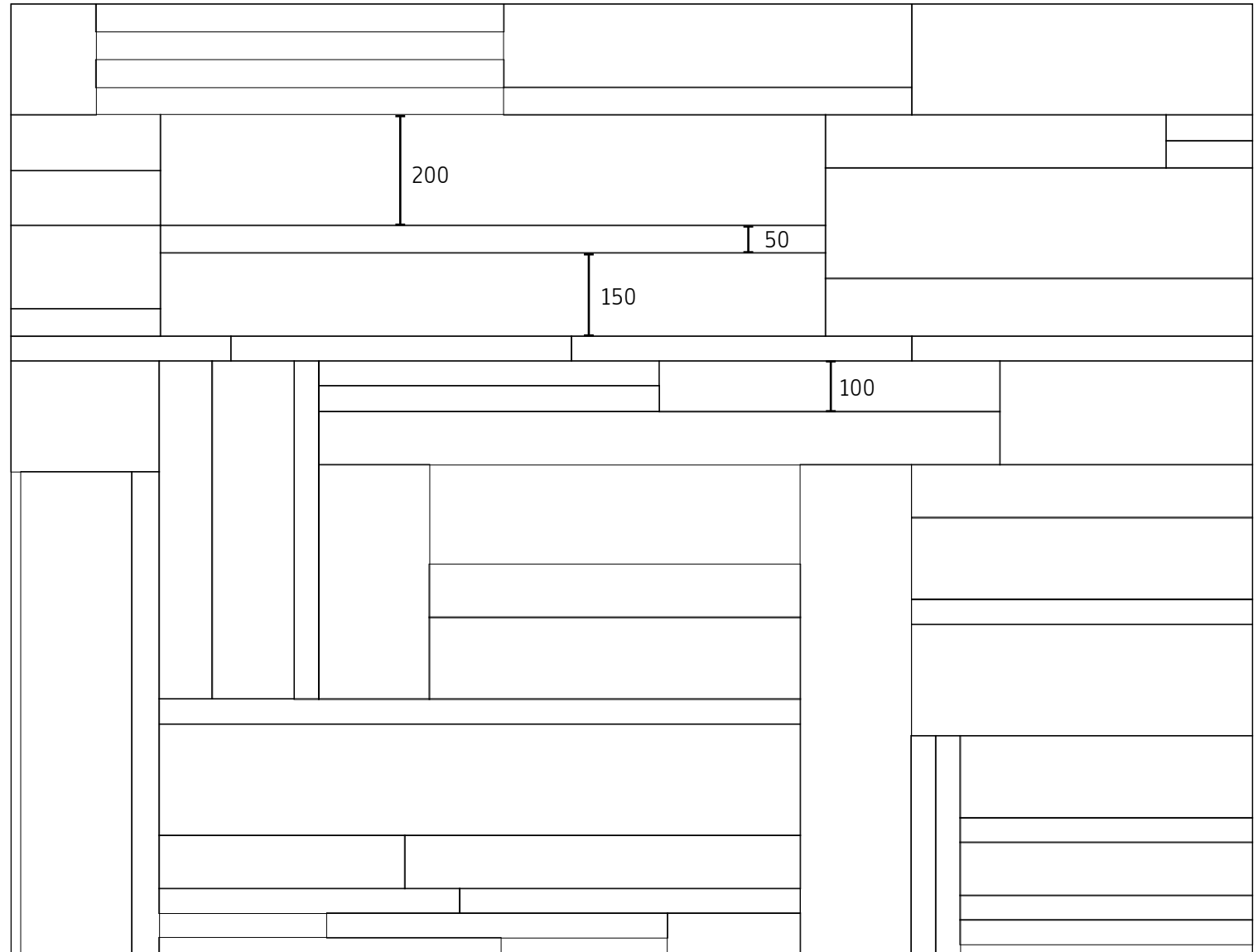

Chevron 45°

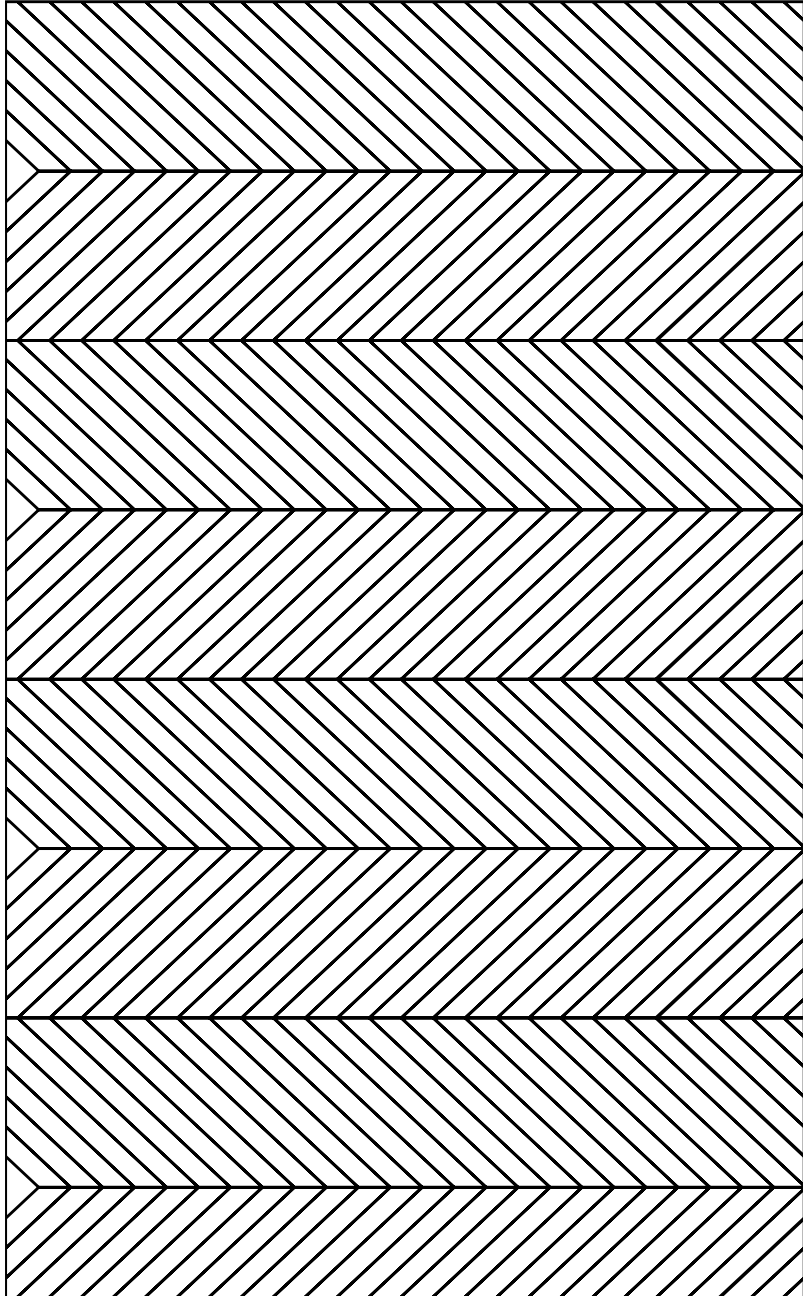

Mixed size chevron

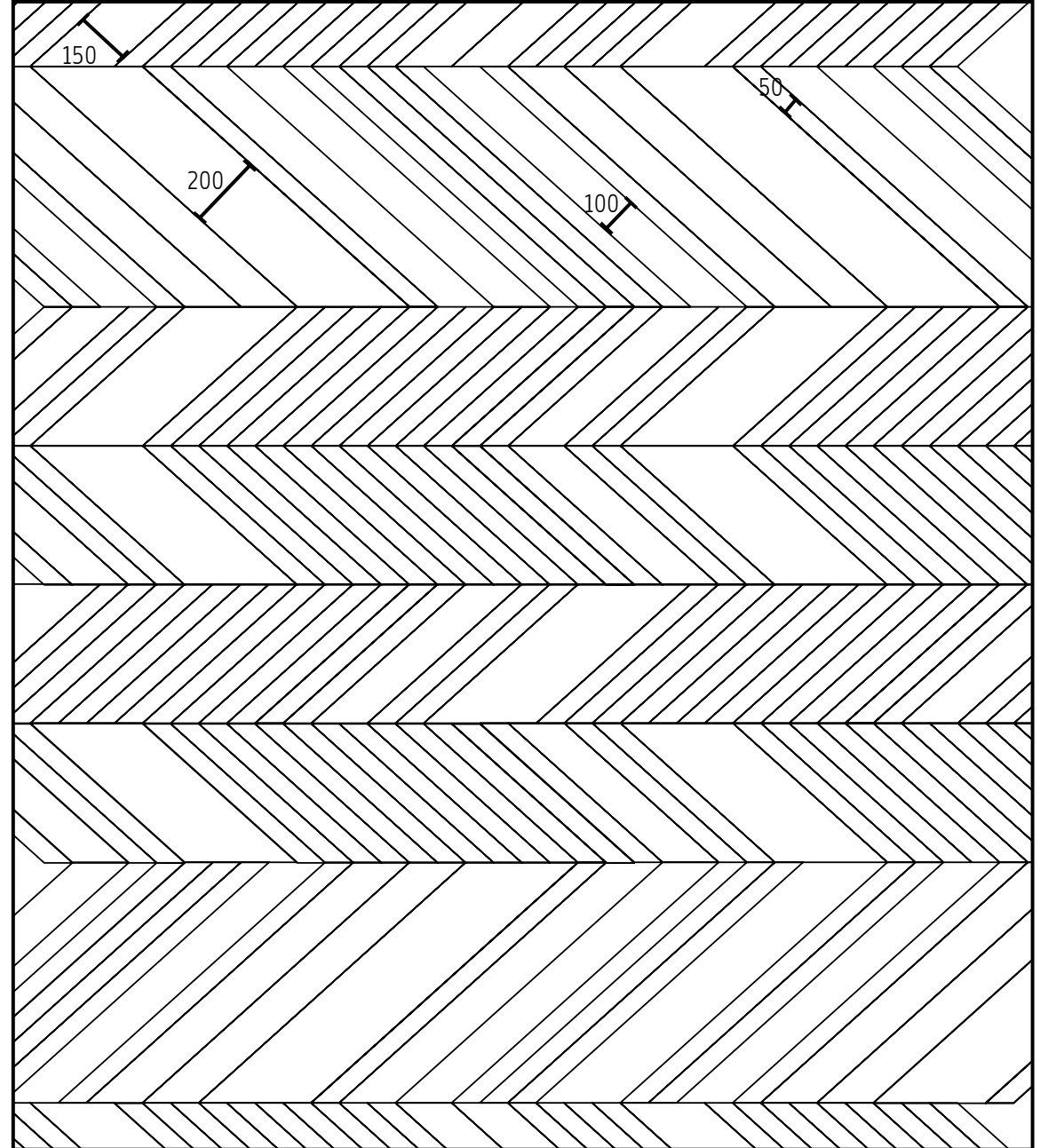

Size and Essences

Total Thickness 15 mm



Parquet: Mixed lengths & Fixed lengths (available upon request)				
50 x 600/1500 mm	50x600 mm	50x1000 mm	50x1200 mm	50x1500 mm
100 x 800/2200 mm	100x600 mm	100x1000 mm	100x1200 mm	100x1500 mm
150 x 800/2200 mm	150x600 mm	150x1000 mm	150x1200 mm	150x1500 mm
200 x 800/2700 mm	200x600 mm	200x1200 mm	200x1500 mm	

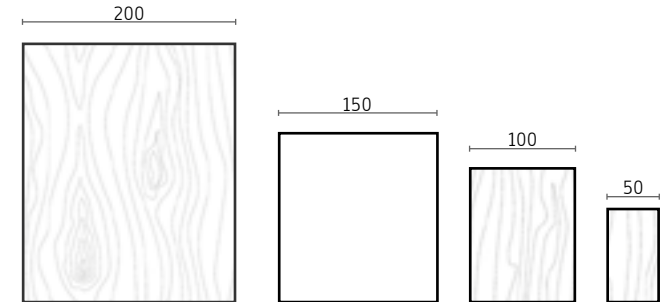

Chevron 45°				
50 x 350 mm	50x600 mm	50x1000 mm	50x1200 mm	50x1500 mm
100 x 383 mm	100x600 mm	100x1000 mm	100x1200 mm	100x1500 mm
150 x 362 mm	150x600 mm	150x1000 mm	150x1200 mm	
200 x 483 mm	200x1000 mm	200x1500 mm		

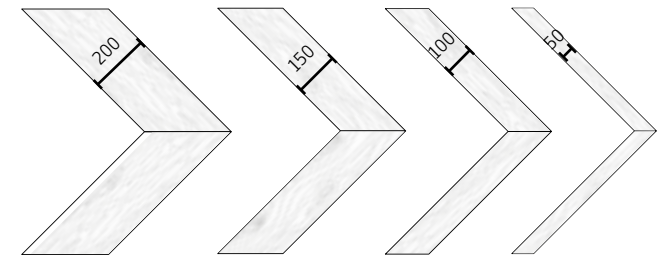

Upon request

Different type of inlays



Different Essences



Different thickness



Solid Wood





Modular Parquet & Geometric Figures

Modular Parquet

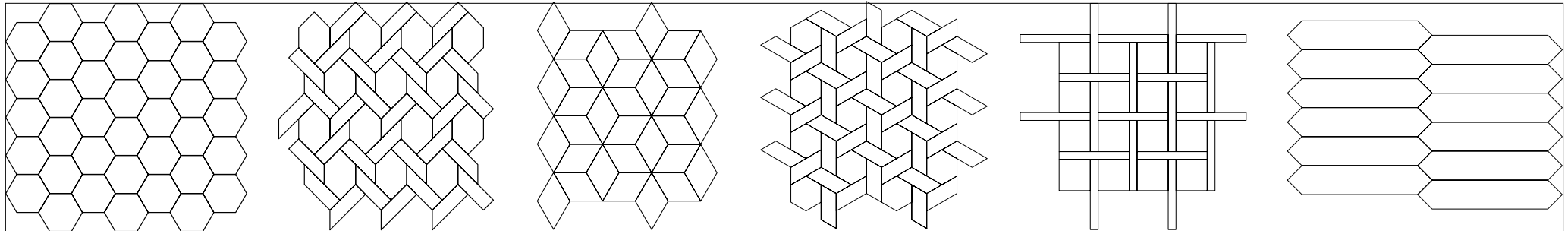

Esagoni

Vimini

Palladio

Intrecci

Scozzese

Spada

Geometric Figures



Angarano

Arvedi

Barbarigo

Ca' Marcello

Capodilista

Chiericati

Contarena

Contarini

Cordellina



Emo

Foscari

Tiepolo

Trissino

Valmarana

Venier

Versailles

Vescovi

Malinverni



Esagoni

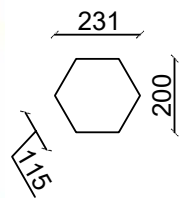

Spade

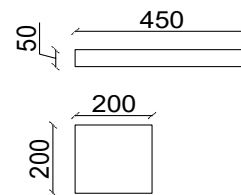
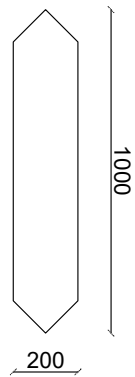

Scozzese



Intrecci

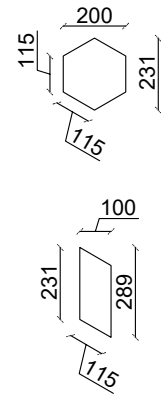

Vimini

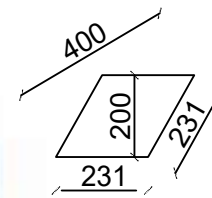
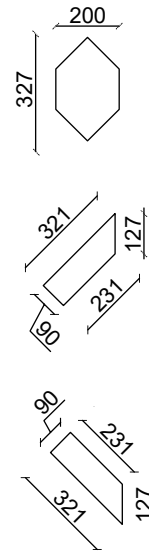

Palladio









Angarano

600

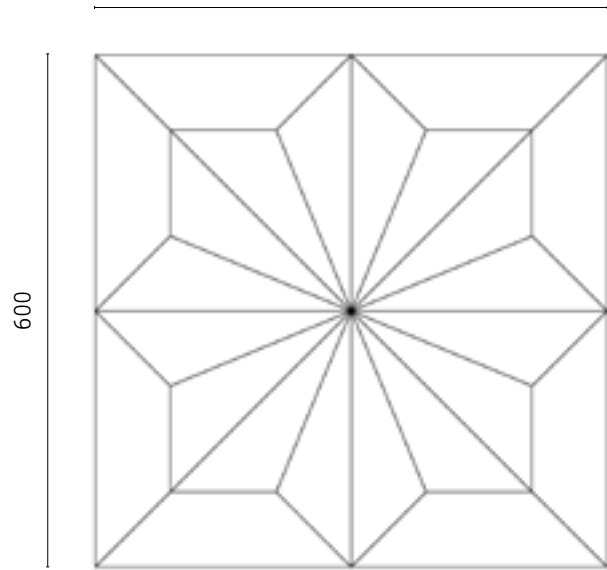

Arvedi

600

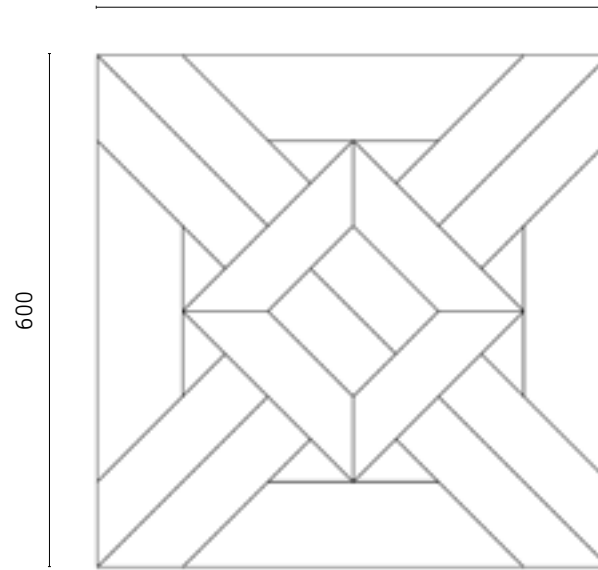

Barbarigo

600

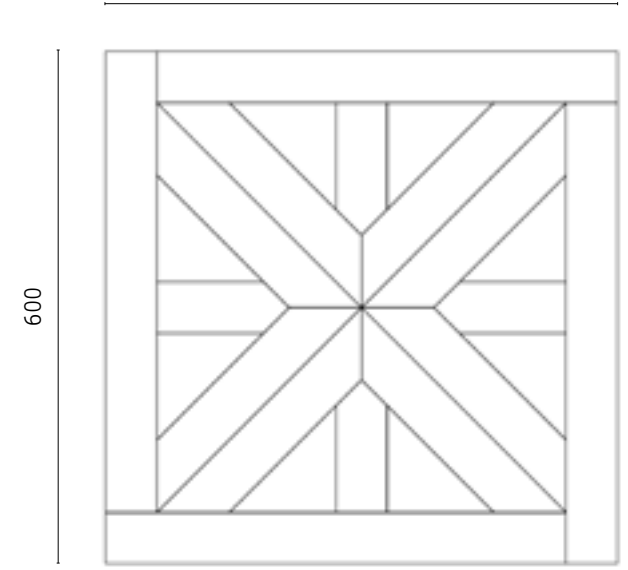

Ca' Marcello

600

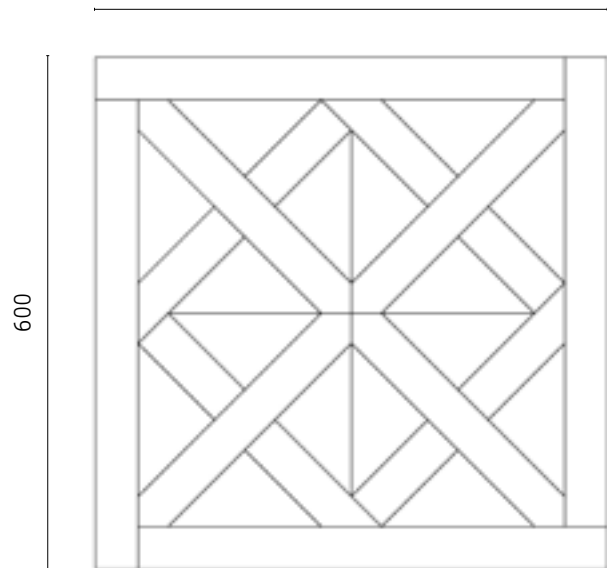

Chiericati

600

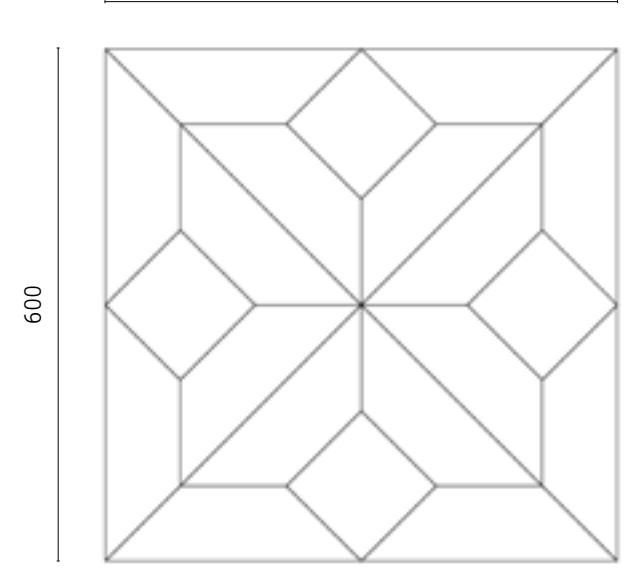

Size: 600x600 mm

Thickness: 15/4 mm

Finish: Smooth or slightly brushed surface, transparent varnish

It's possible to have bevel on the perimeter or on all elements.

Capodilista

600

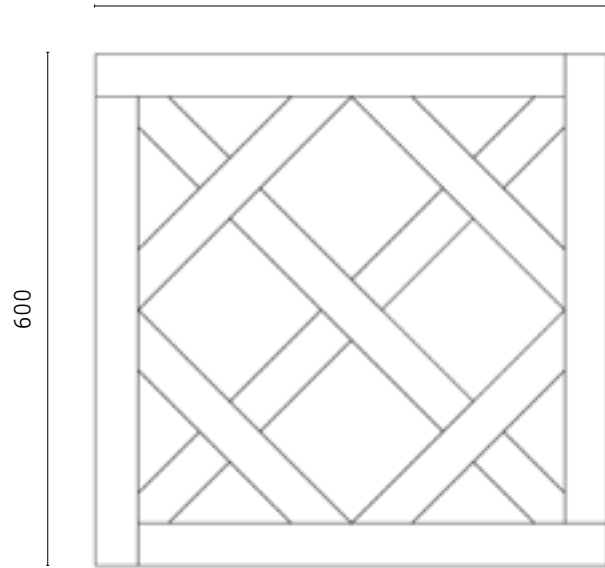

Contarena

600

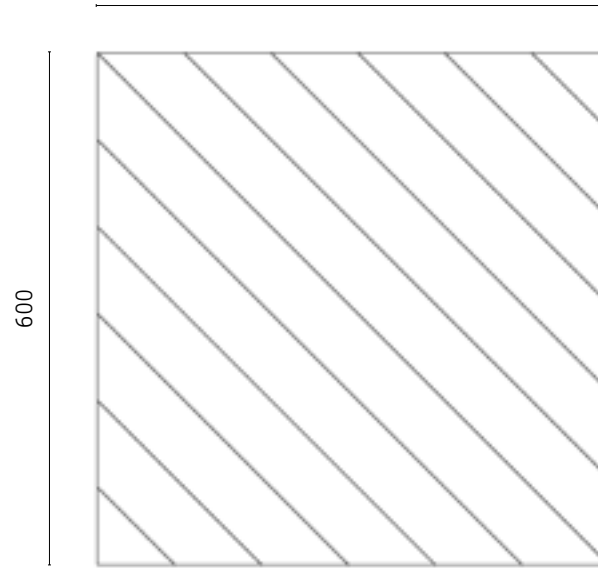

Contarini

600

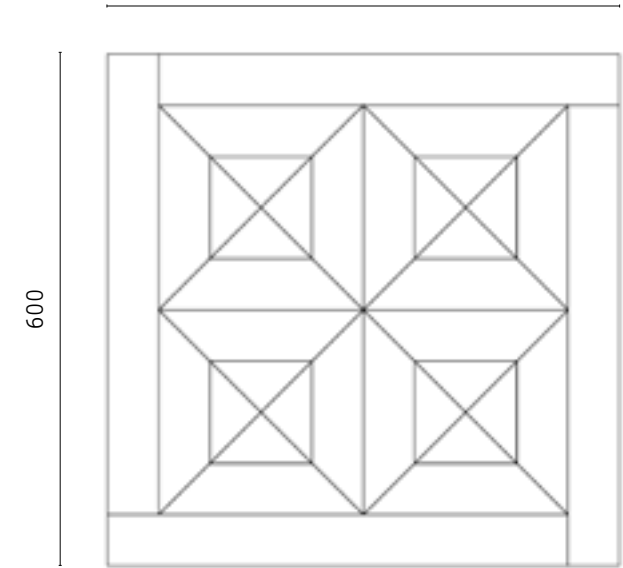

Cordellina

600

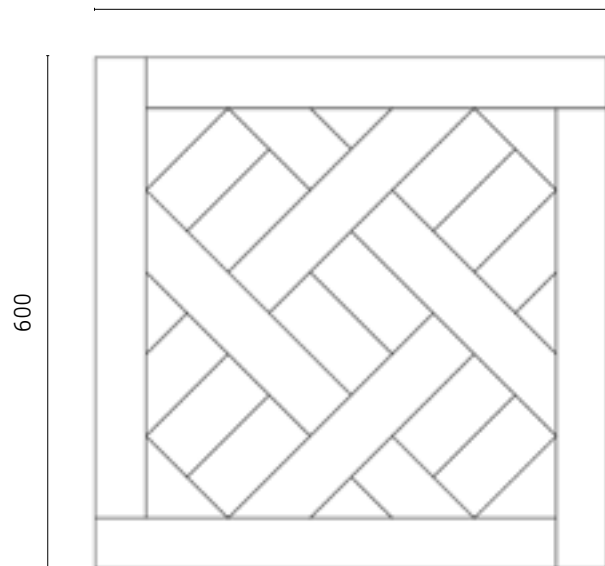

Emo

600

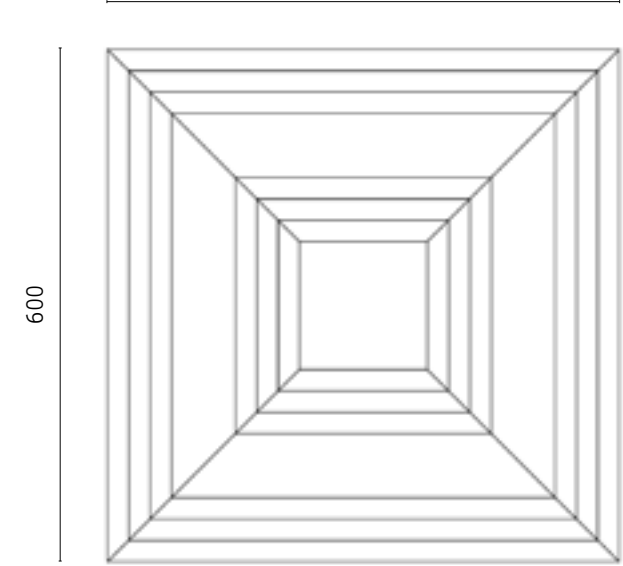

Size: 600x600 mm

Thickness: 15/4 mm

Finish: Smooth or slightly brushed surface, transparent varnish

It's possible to have bevel on the perimeter or on all elements. *(except on Emo tile).*

Foscari

600

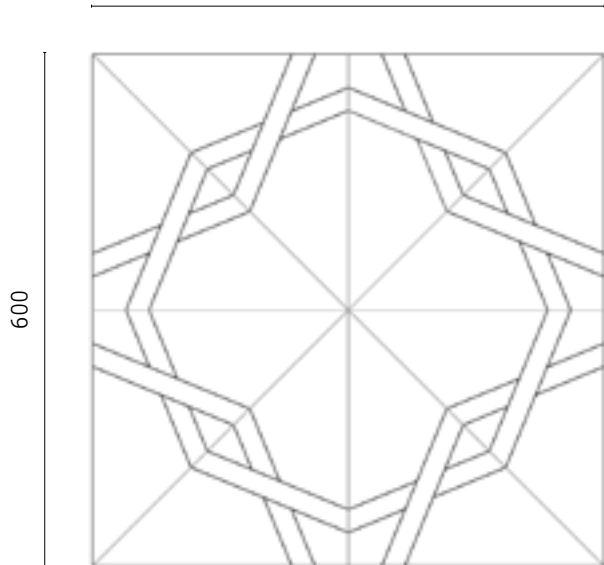

Malinverni

600

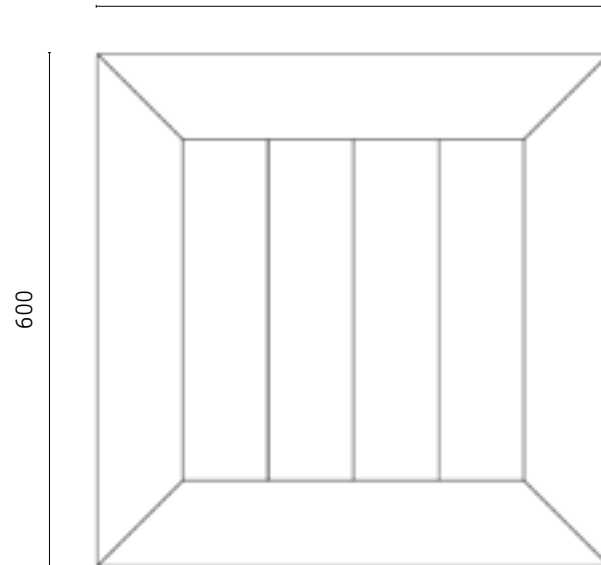

Tiepolo

600

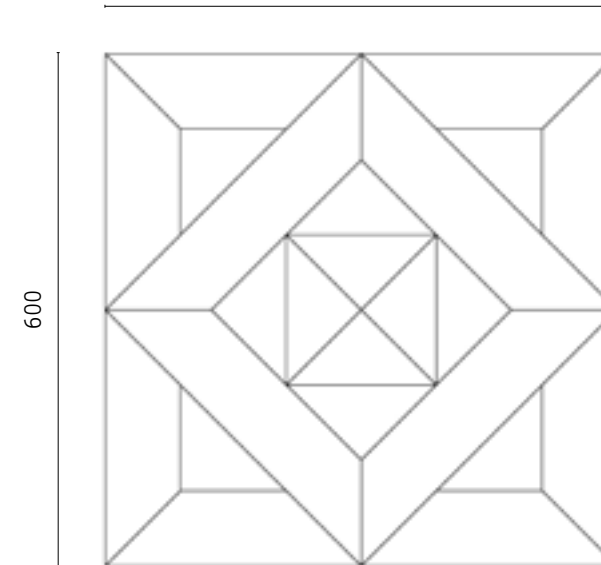

Trissino

600

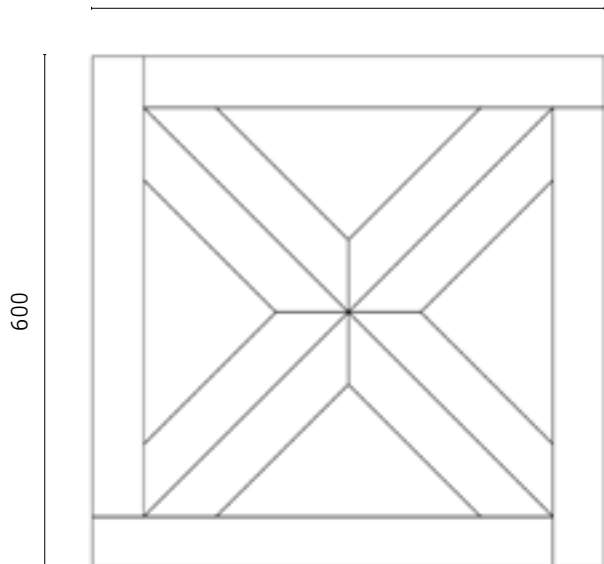

Valmarana

600

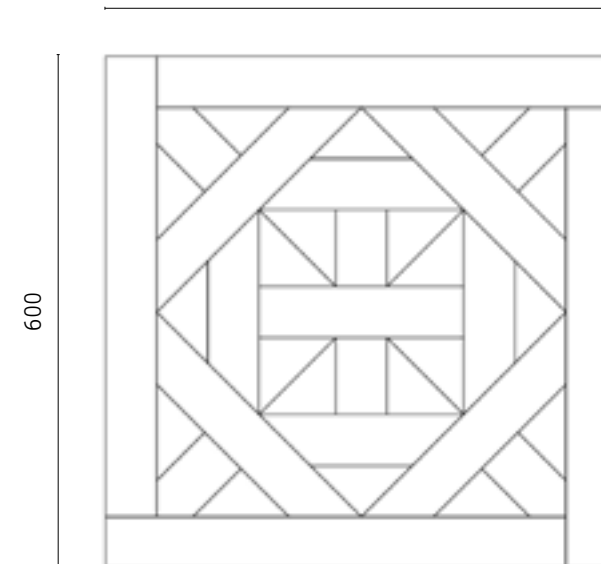

Size: 600x600 mm

Thickness: 15/4 mm

Finish: Smooth or slightly brushed surface, transparent varnish

It's possible to have bevel on the perimeter or on all elements. *(except on Foscari tile).*

Venier

600

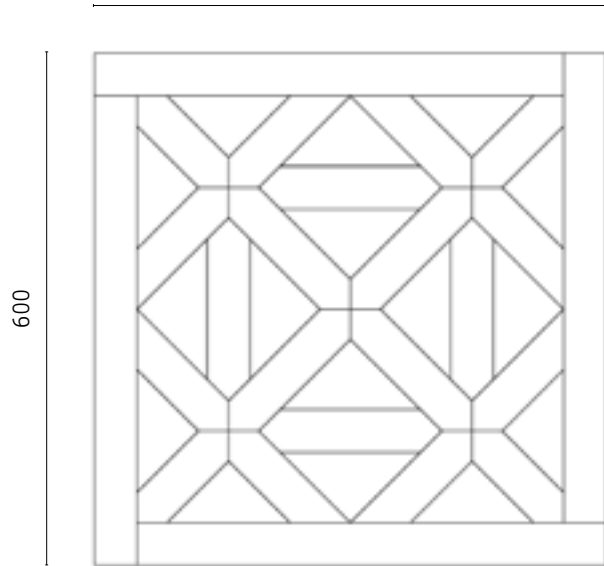

Versailles

980

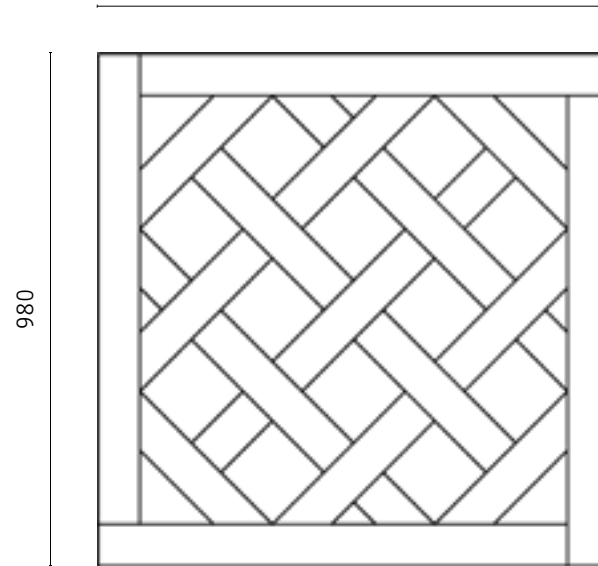

Vescovi

600

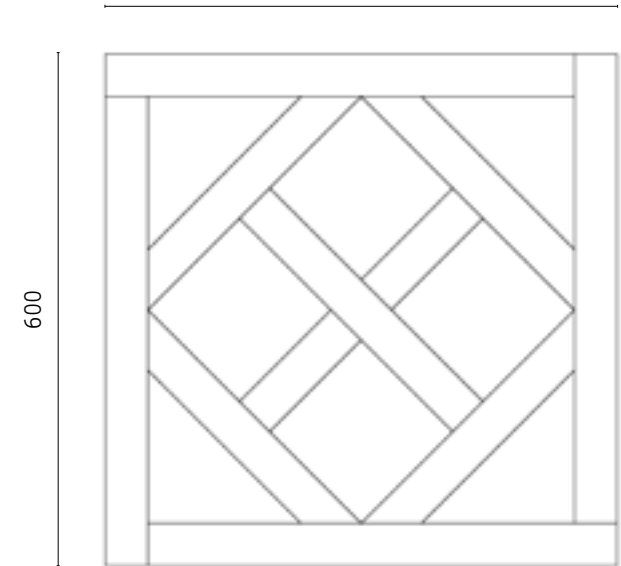

Size: 600x600 mm

Thickness: 15/4 mm

Finish: Smooth or slightly brushed surface, transparent varnish

It's possible to have bevel on the perimeter or on all elements.











Essenze's Tiles

EsSENZE's Tiles

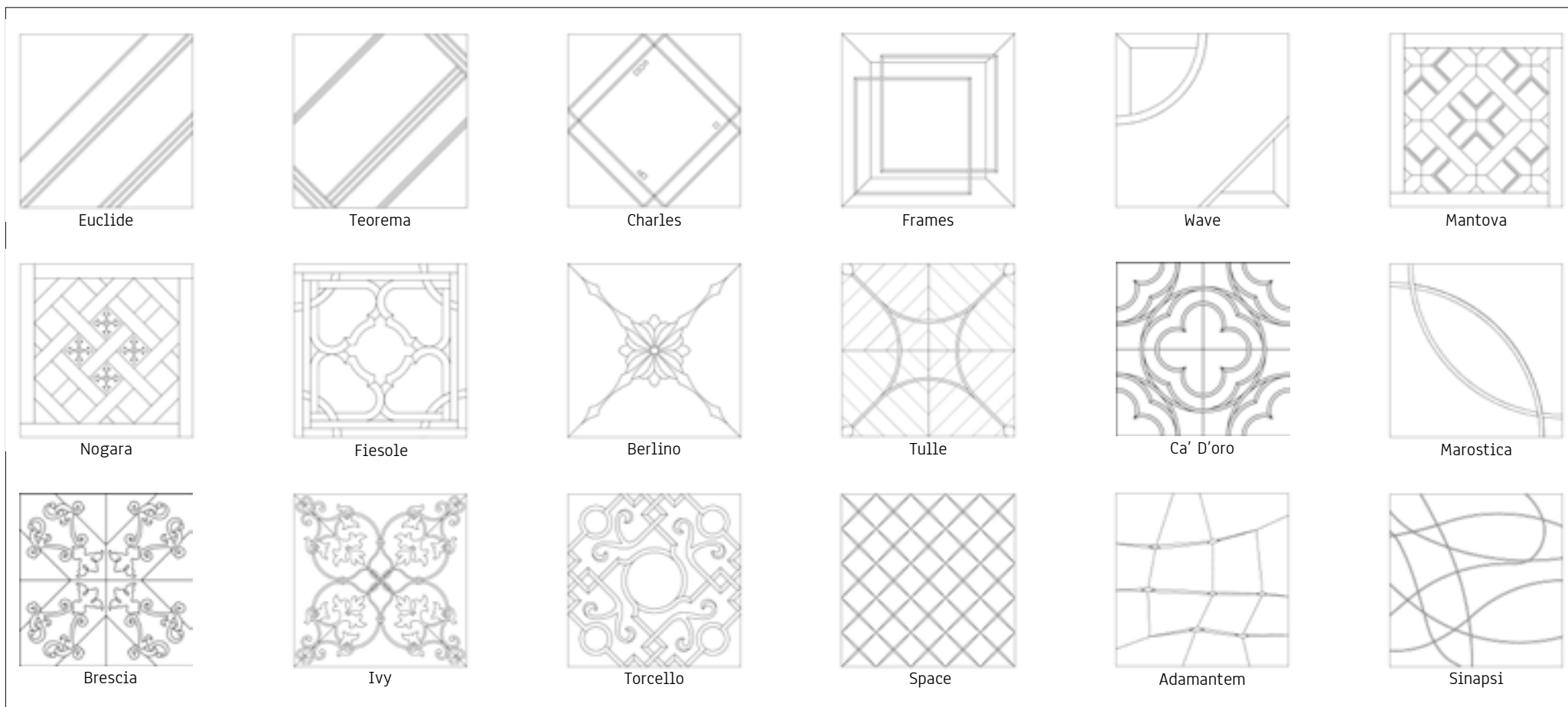

Collezione Ferreri

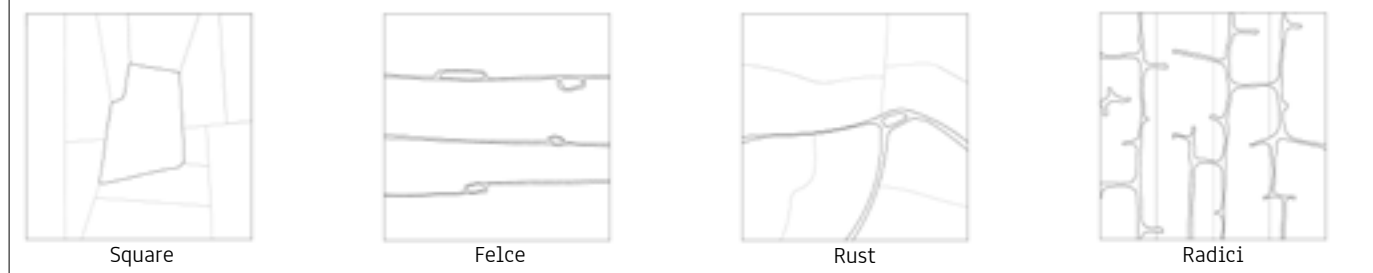



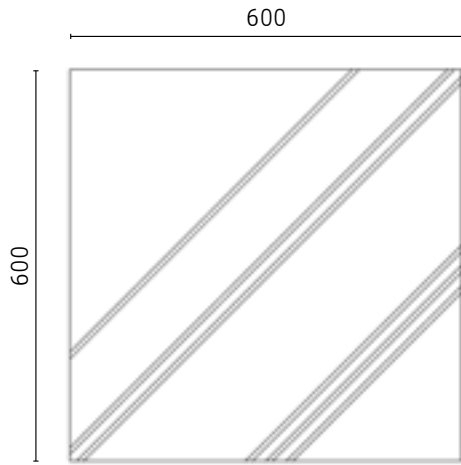

Euclide

Size: 600x600 mm

Thickness: 15/4 mm

Material:

- Oak
- Teak
- Wengè
- White nacre

Finish: Smooth surface, 25 gloss transparent varnish

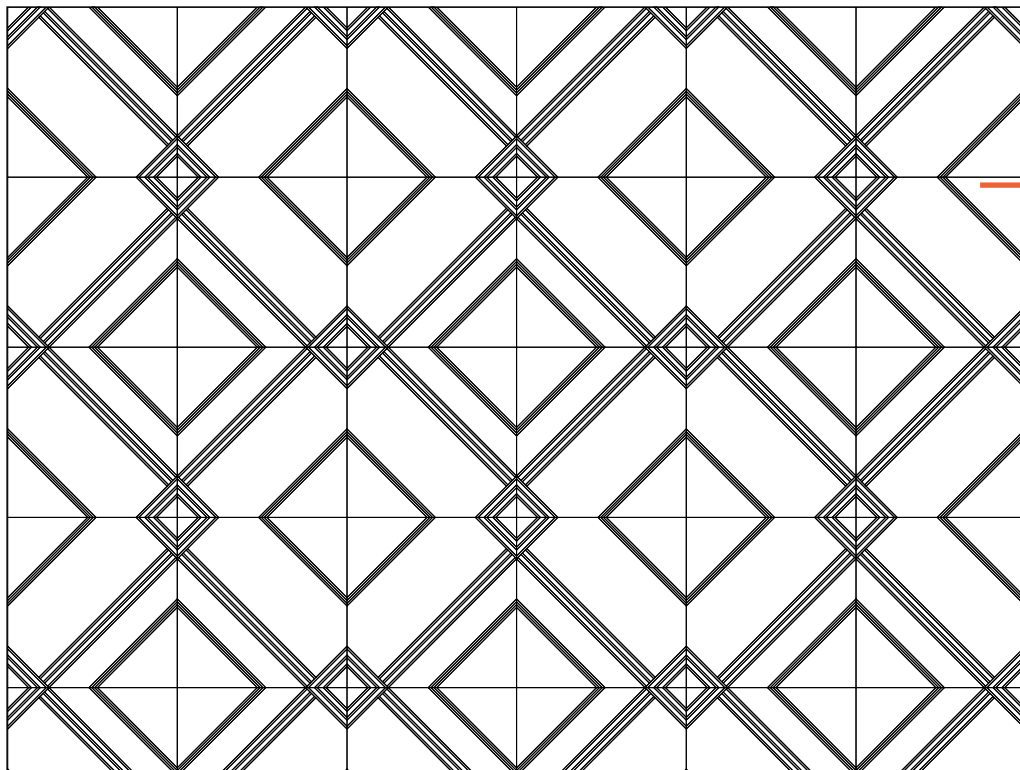
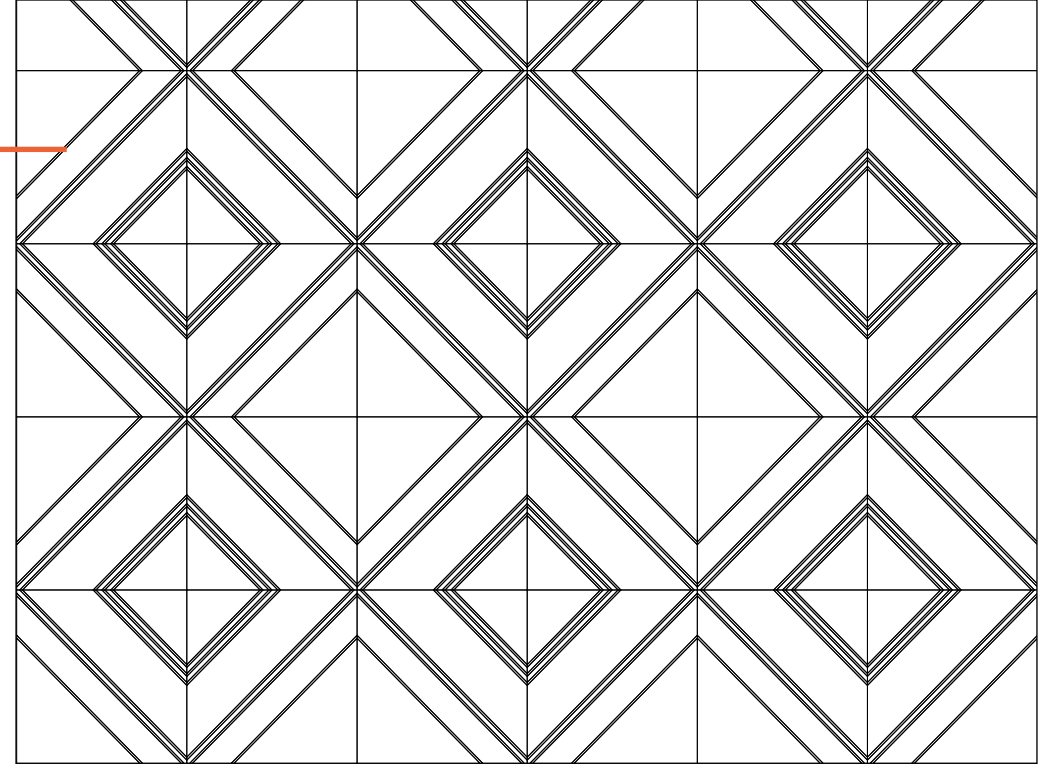

Teorema

Size: 600x600 mm

Thickness: 15/4 mm

Material:

- Maple
- Wengè
- Teak
- American Walnut
- White nacre

Finish: Smooth surface, 25 gloss transparent varnish

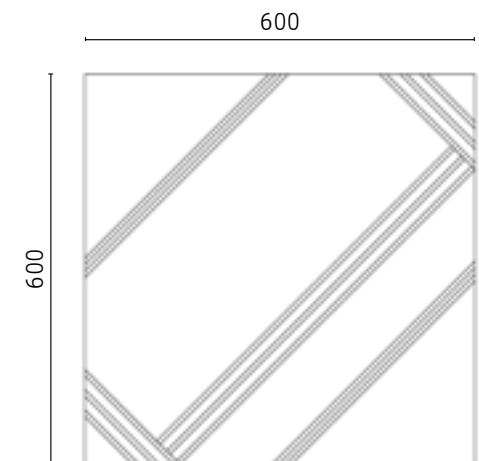

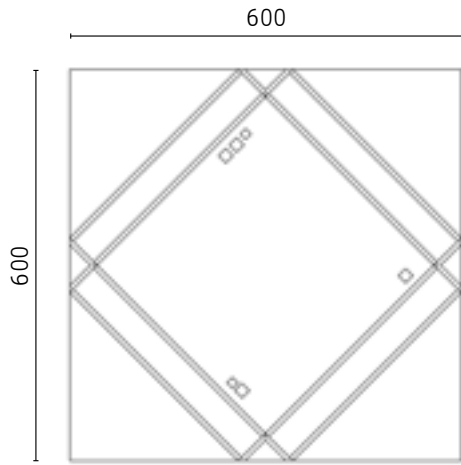

Charles

Size: 600x600 mm

Thickness: 15/4 mm

Material:

- Oak
- Wengè
- Nacre

Finish: Smooth surface, 25 gloss transparent varnish

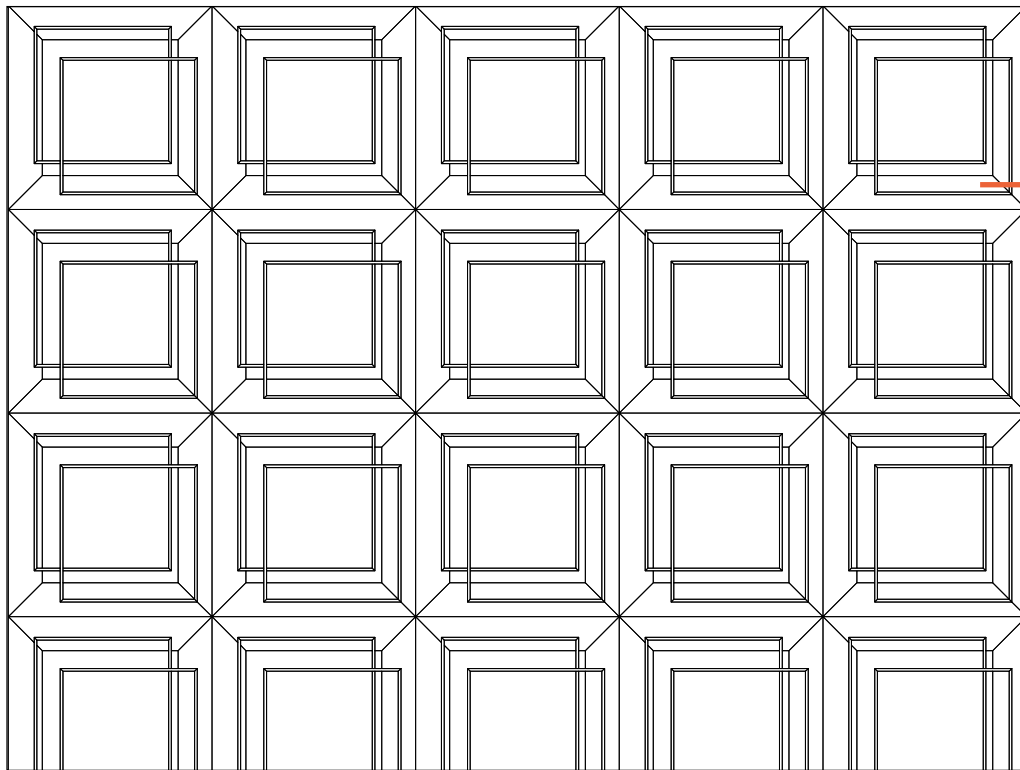
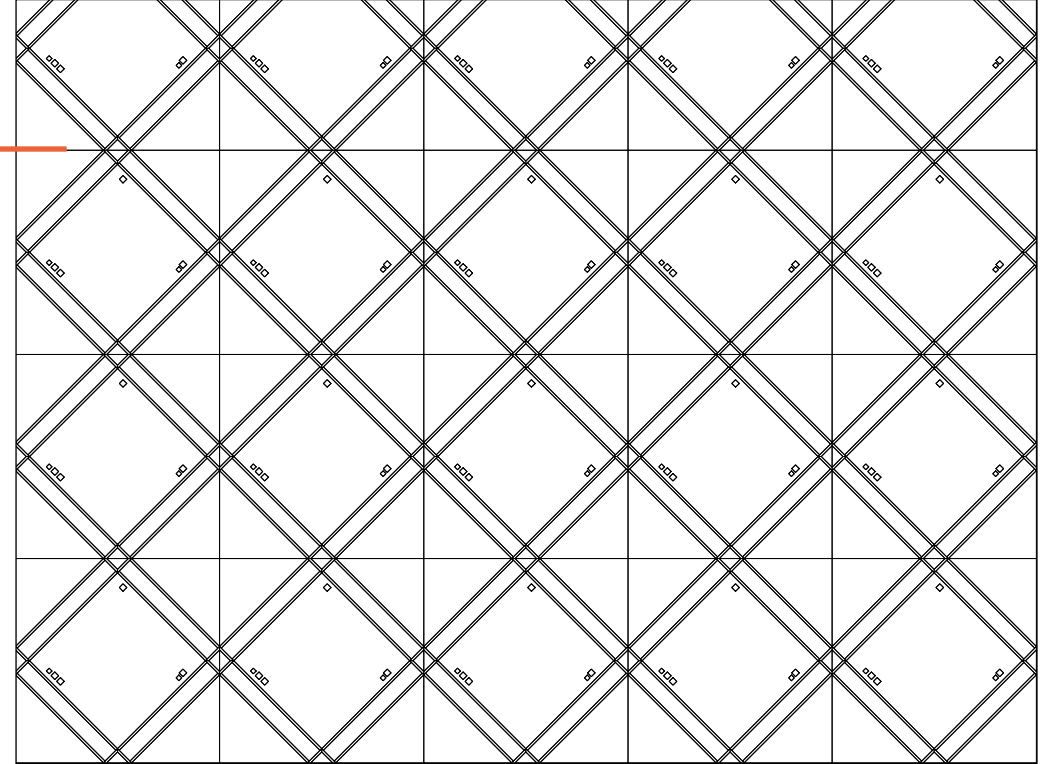

Frames

Size: 600x600 mm

Thickness: 15/4 mm

Material:

- Oak
- Smoked Oak
- White nacre

Finish: Smooth surface, 25 gloss transparent varnish

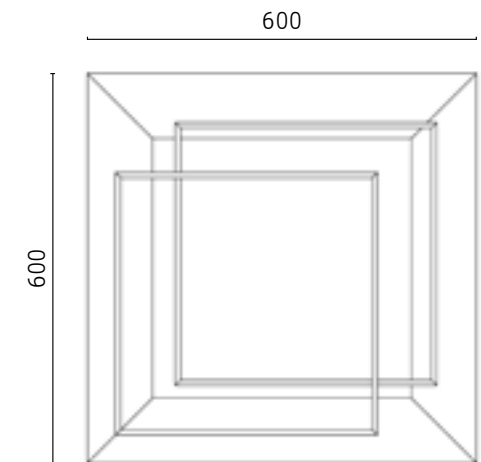





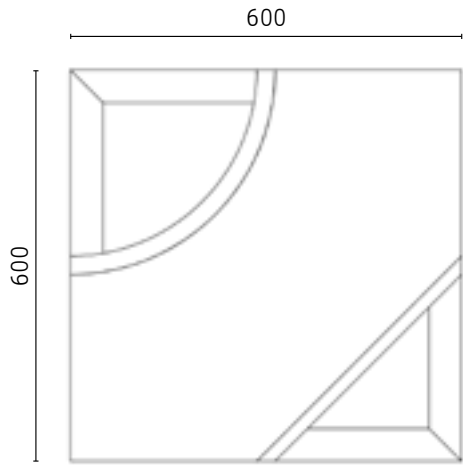

Wave

Size: 600x600 mm

Thickness: 15/4 mm

Material:

- Oak
- Walnut
- Aluminium
- Nacre

Finish: Smooth surface, tint finish in the center and transparent varnish

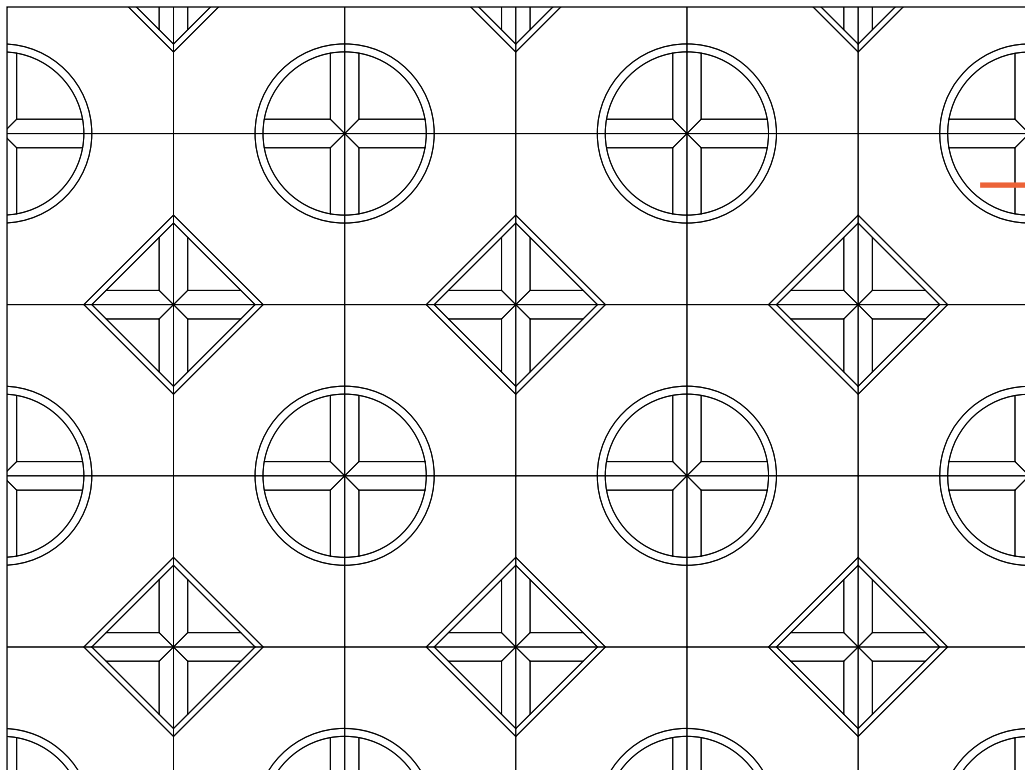
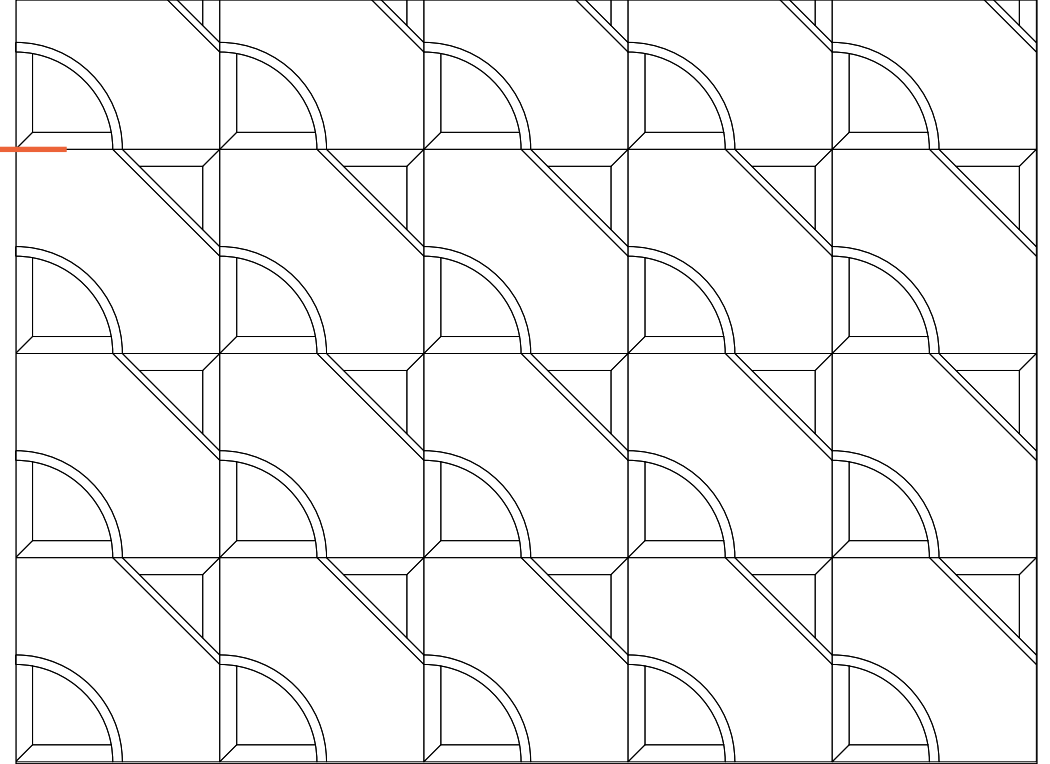

Alternative laying pattern





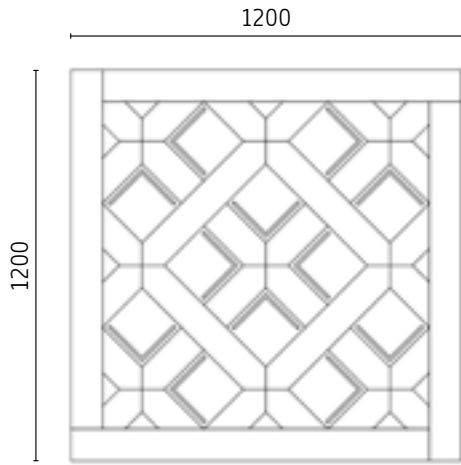

Mantova

Size: 1200x1200 mm

Thickness: 15/4 mm

Material:

- Oak
- Alluminium

Finish: Smooth surface, oiled

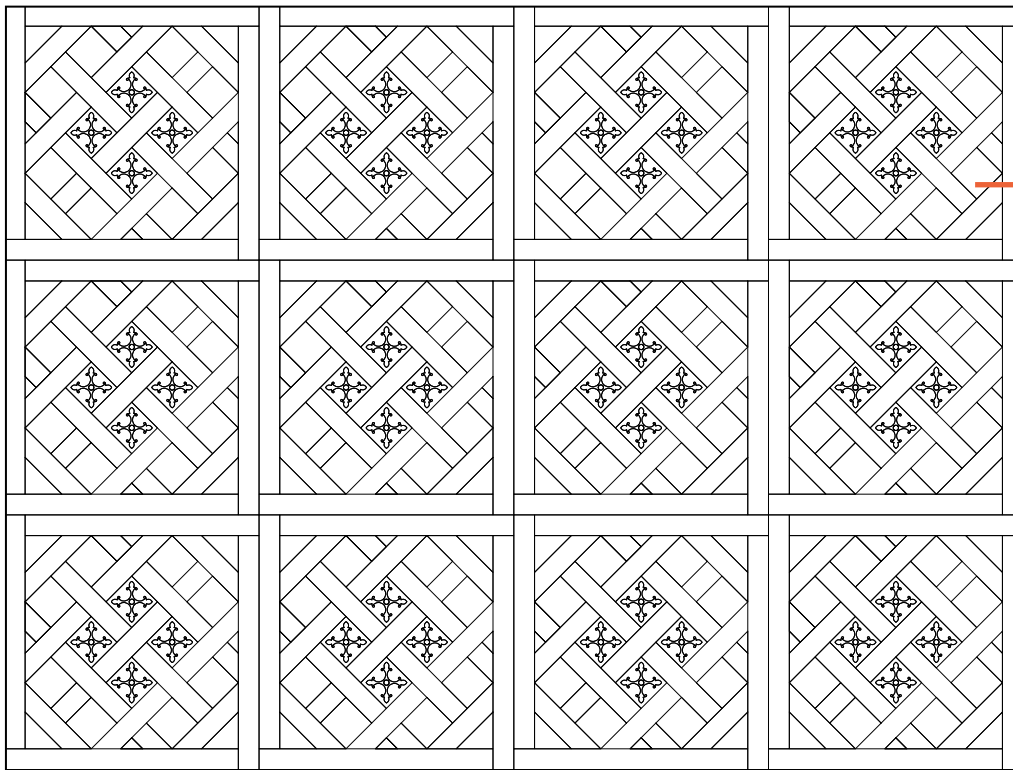
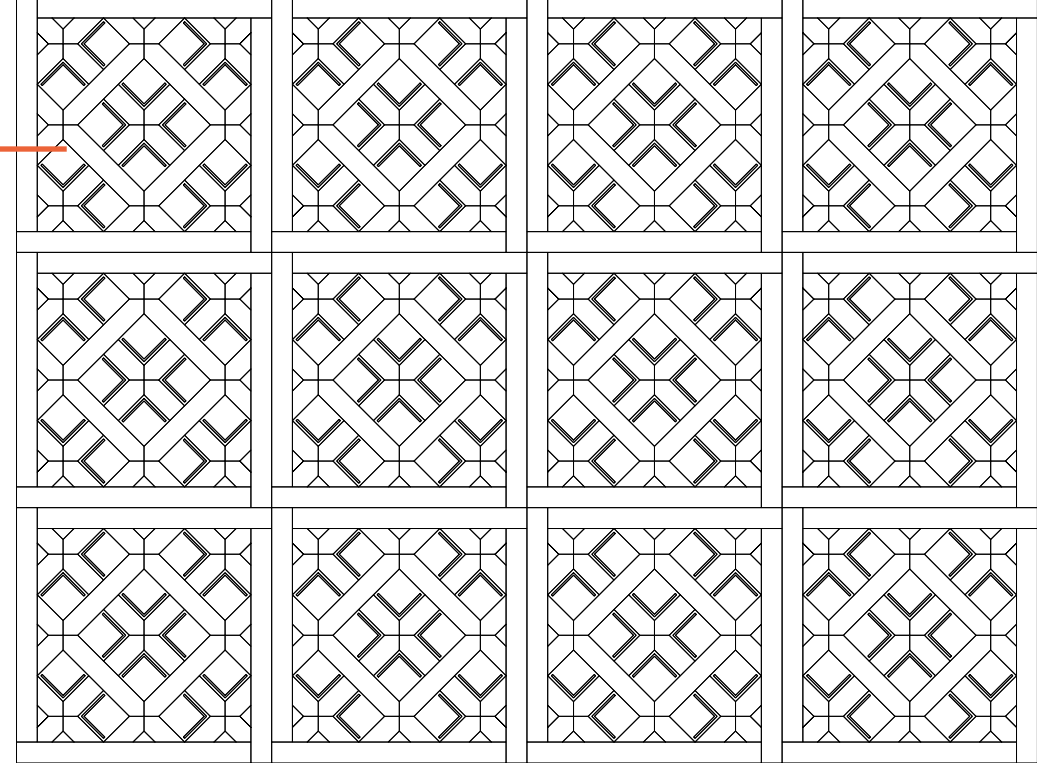

Nogara

Size: 1200x1200 mm

Thickness: 15/4 mm

Material:

- Oak
- Brass

Finish: Smooth surface, antiqued oil

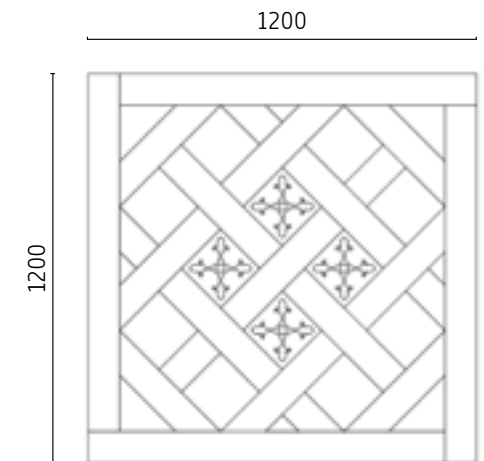

[Back to Contents](#)



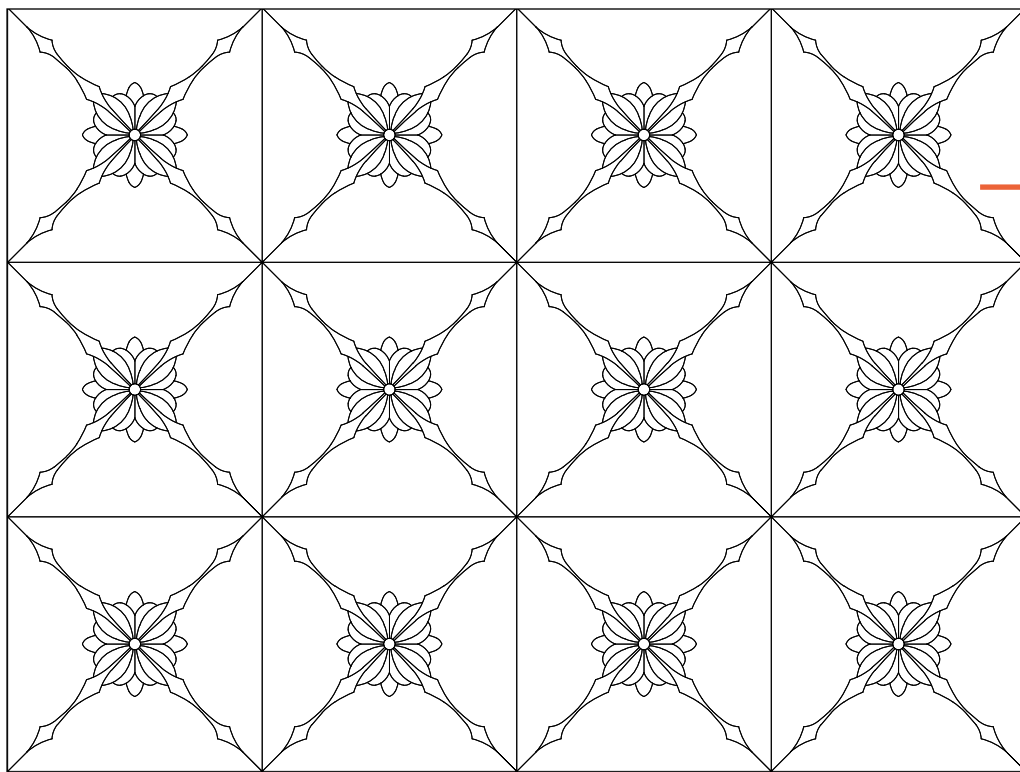

Berlino

Size: 600x600 mm

Thickness: 15/4 mm

Material:

- American Walnut
- Doussiè
- Nacre

Finish: Smooth surface, 25 gloss transparent varnish

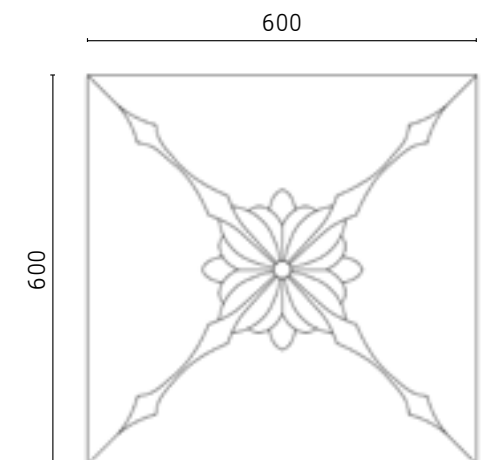

[Back to Contents](#)



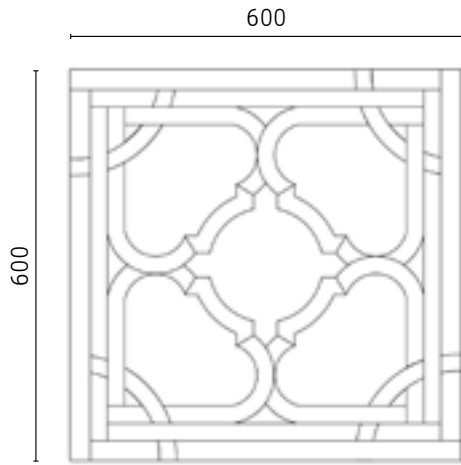

Fiesole

Size: 600x600 mm

Thickness: 20/4 mm

Material:

- Oak
- Carrara Marble (th. 10 mm)

Finish: Slightly brushed surface, transparent varnish

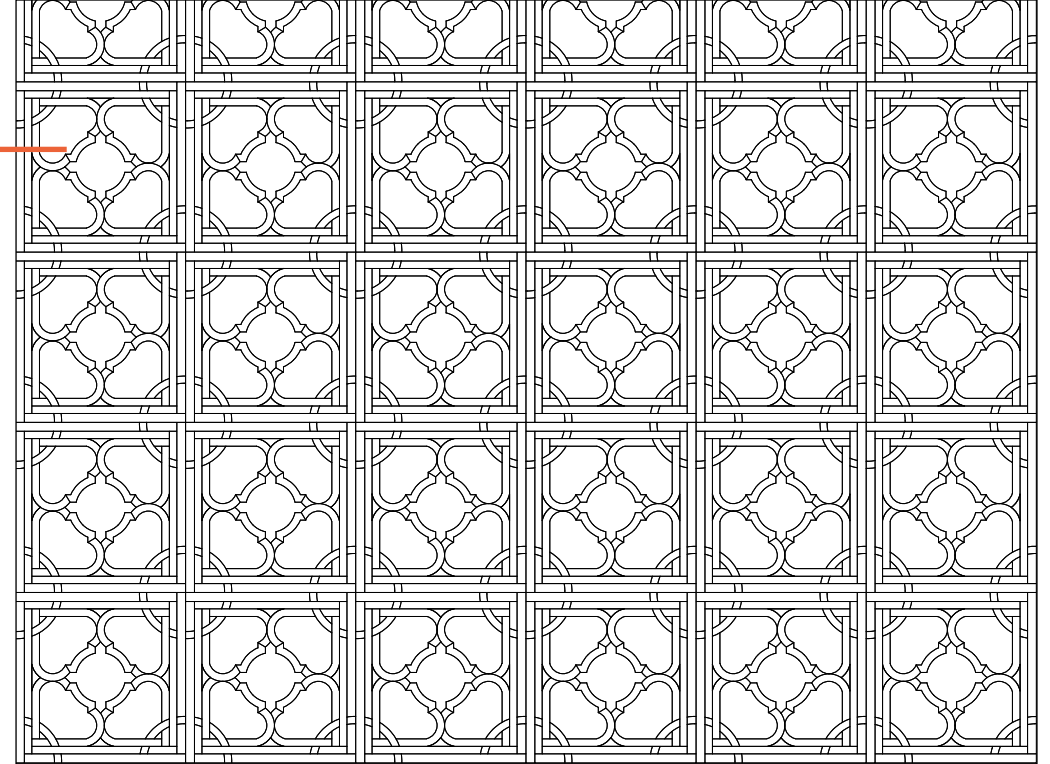

Different versions available



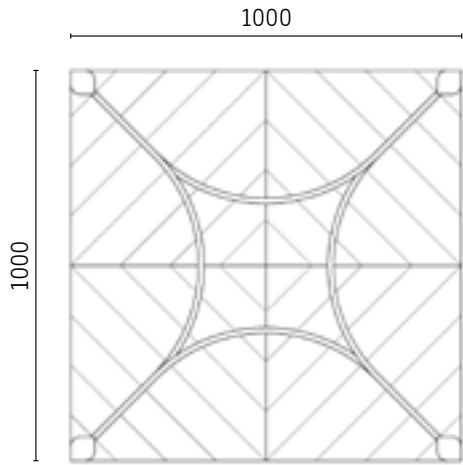

Tulle

Size: 1000x1000 mm

Thickness: 15/4 mm

Material:

- Oak
- Brass

Finish: Smooth surface, transparent varnish (inner elements not bevelled)

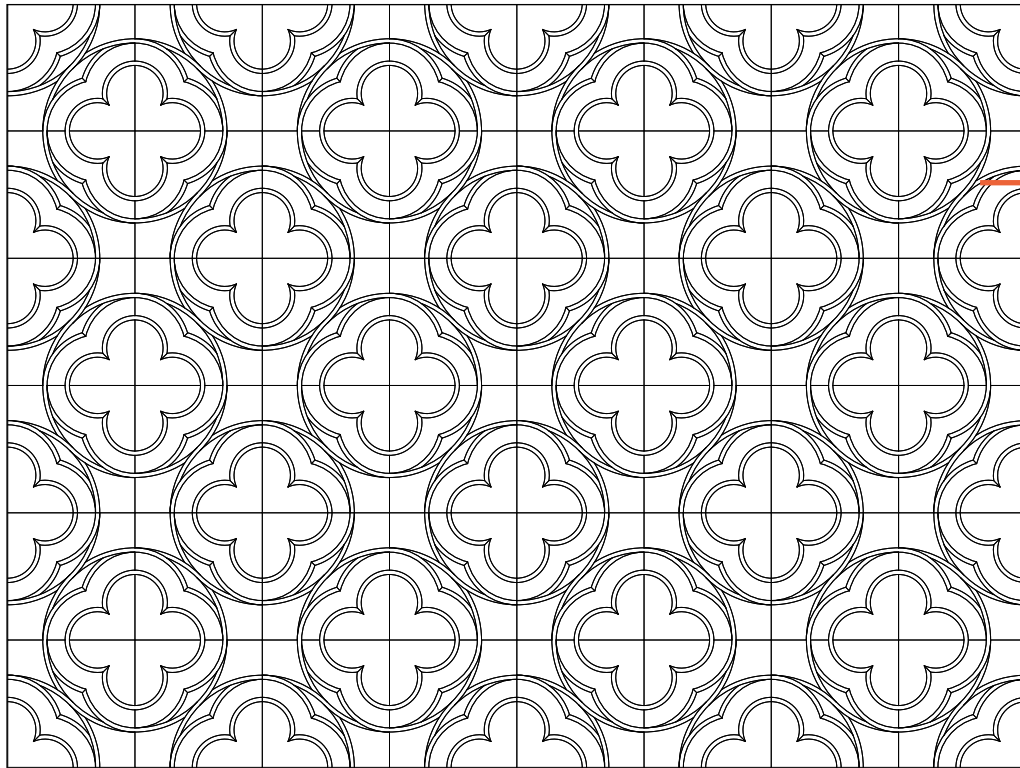
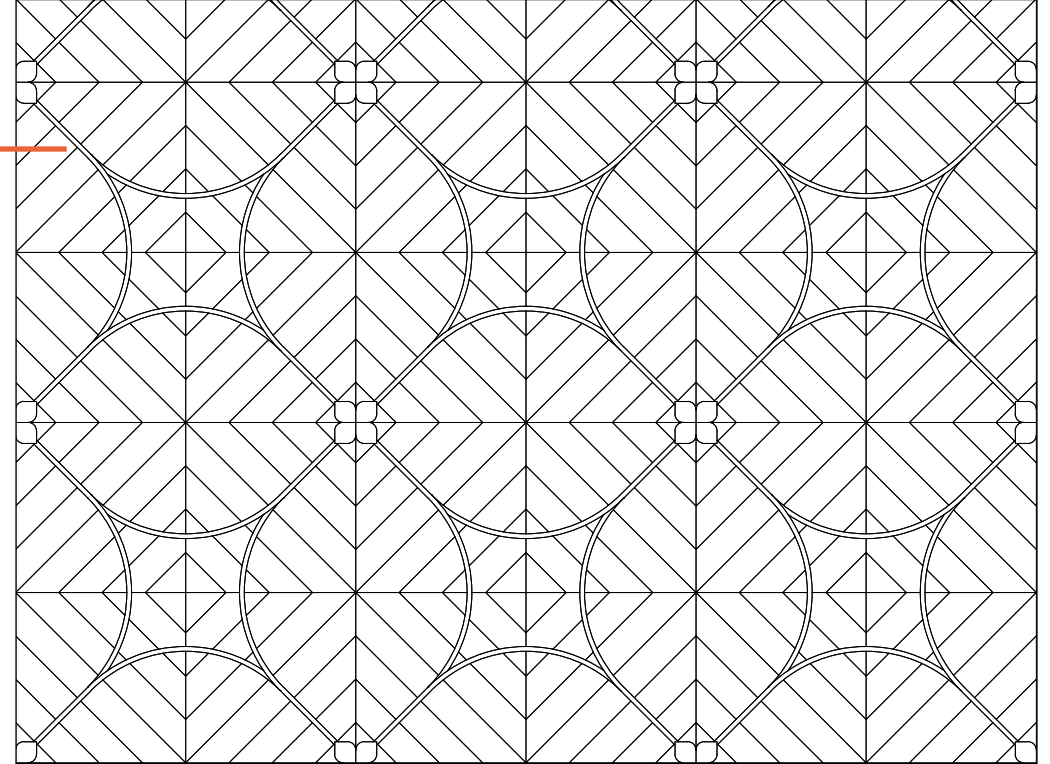

Ca' D'Oro

Size: 600x600 mm

Thickness: 15/4 mm

Material:

- Oak
- Maple

Finish: Smooth surface, transparent varnish

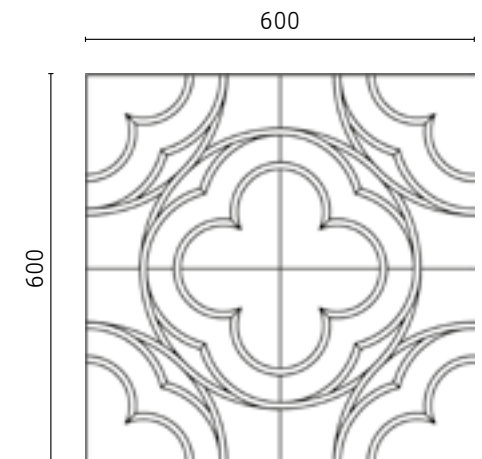

[Back to Contents](#)



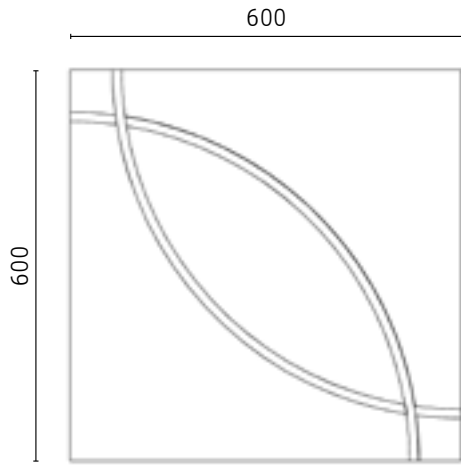

Marostica

Size: 600x600 mm

Thickness: 15/4 mm

Material:

- American walnut
- Nacre

Finish: Smooth surface, transparent varnish 25 gloss

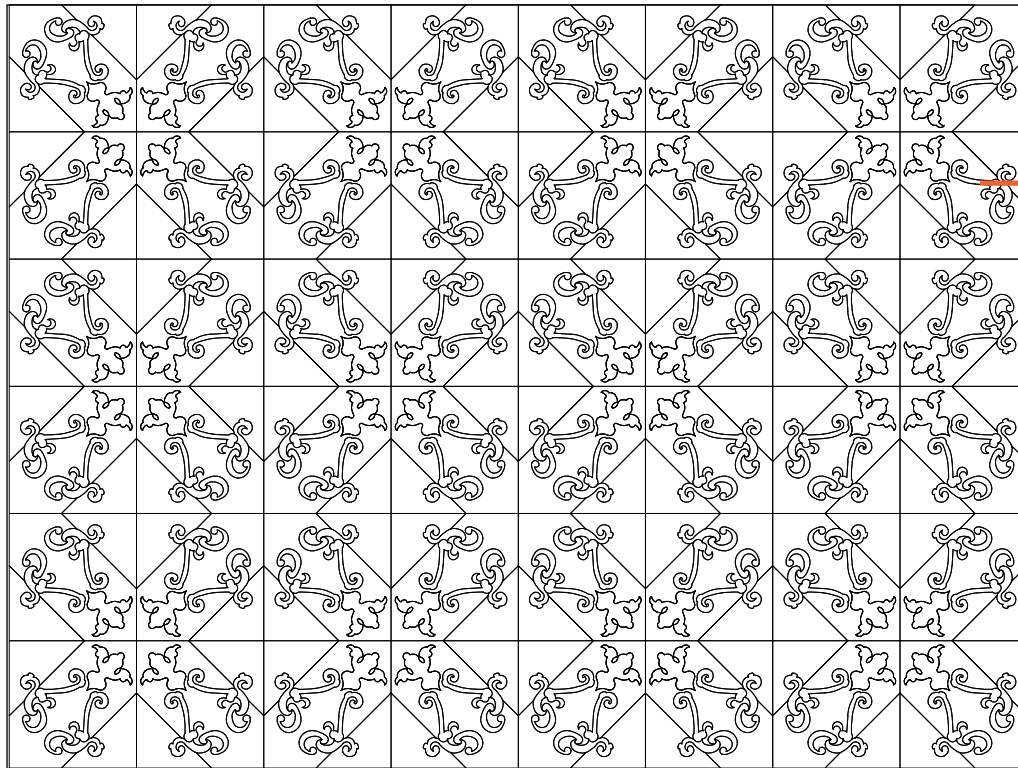
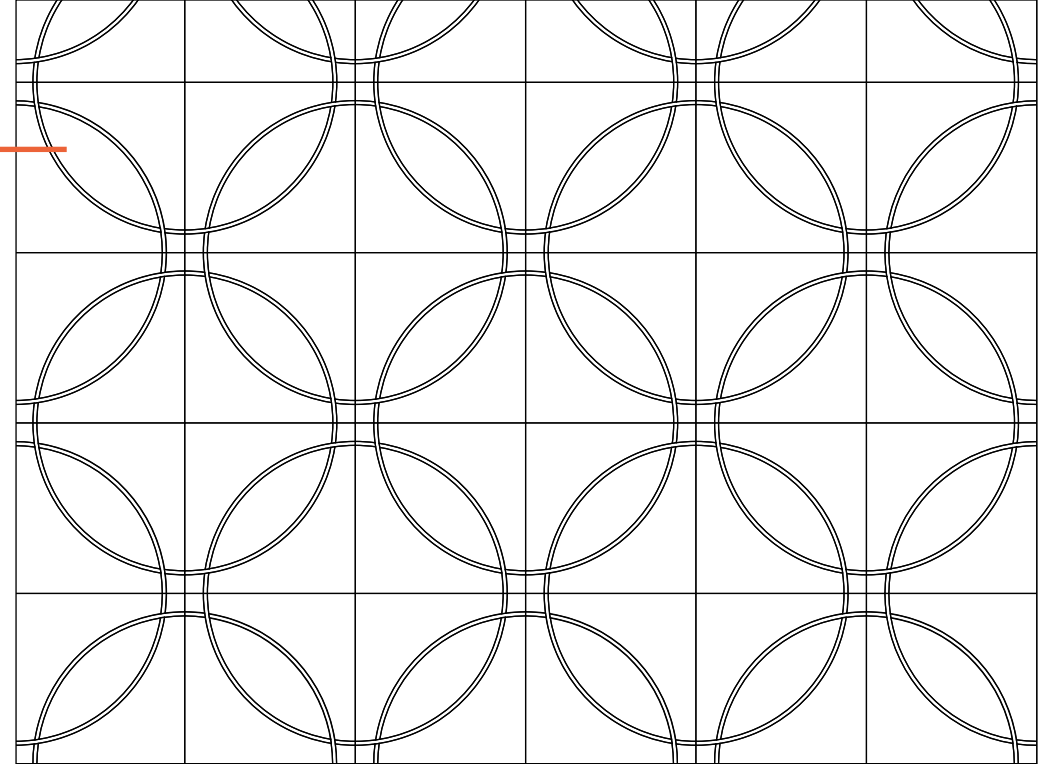

Brescia

Size: 600x600 mm

Thickness: 15/4 mm

Material:

- Oak (Comfort)

Finish: Smooth surface, transparent varnish 0 gloss

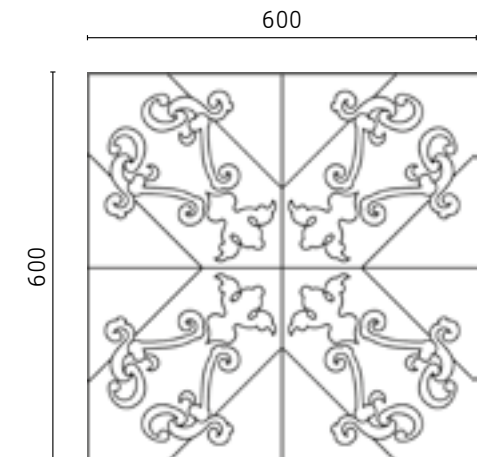

[Back to Contents](#)



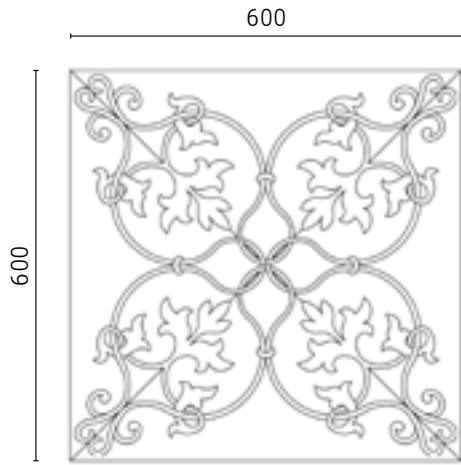

Ivy

Size: 600x600 mm

Thickness: 15/4 mm

Material:

- Oak (Comfort)

Finish: Smooth surface, wax finishing

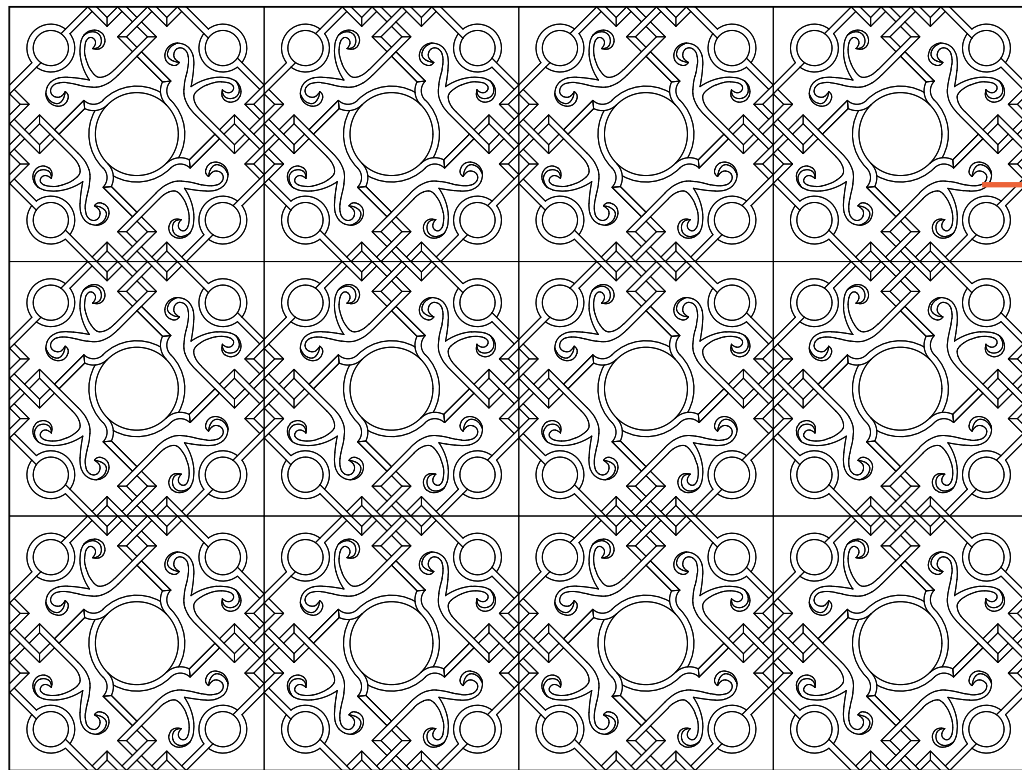
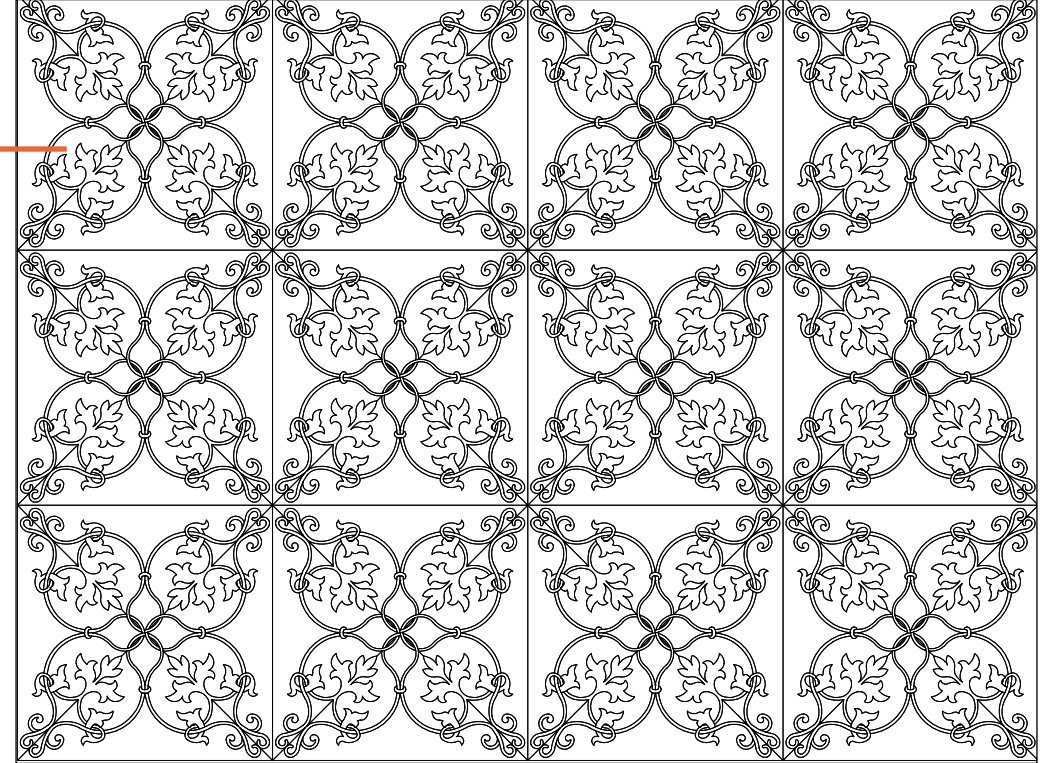

Torcello

Size: 900x900 mm

Thickness: 20/4 mm

Material:

- Walnut
- Wengè
- Oak
- Travertino marble (th. 9 mm)
- Brass (th. 4 mm)

Finish: Soft touch surface, wax finishing

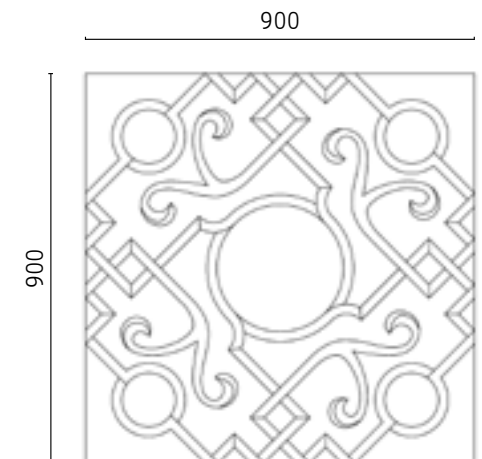

[Back to Contents](#)



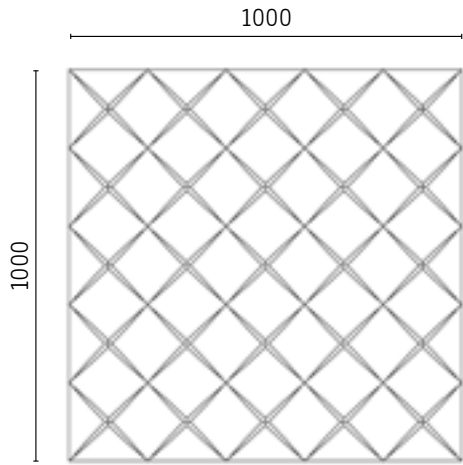

Space

Size: 1000x1000 mm

Thickness: 15/4 mm

Material:

- Wengè
- Brass

Finish: Transparent varnish 15 gloss - smooth surface

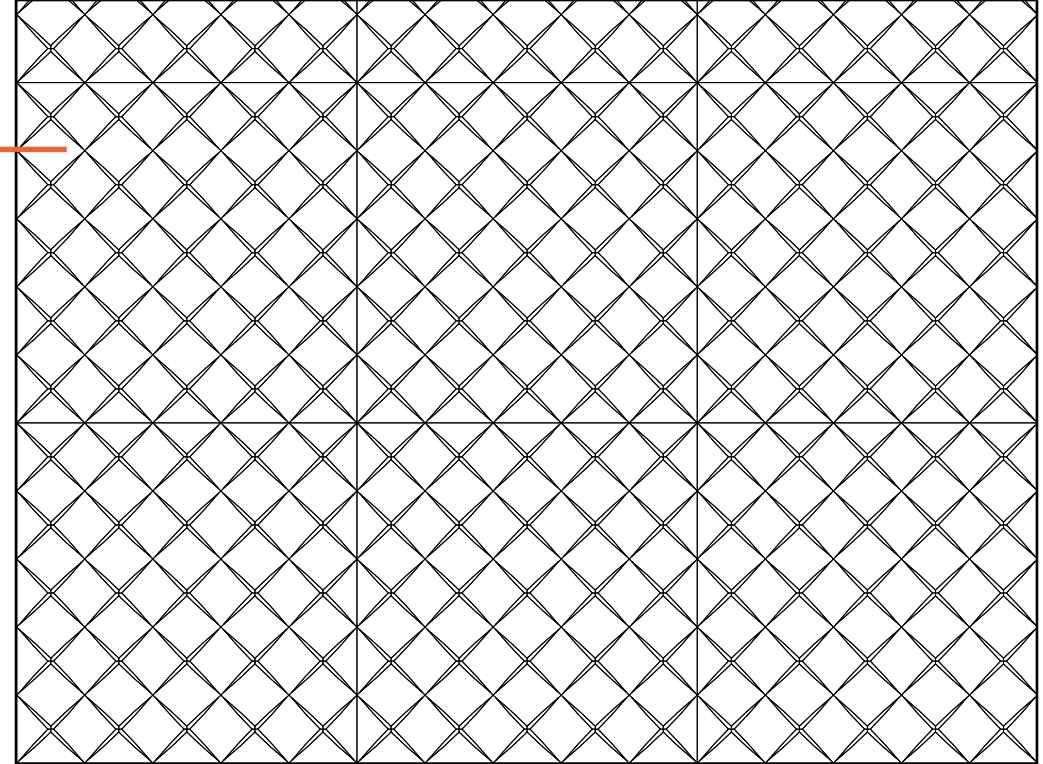

Different versions available



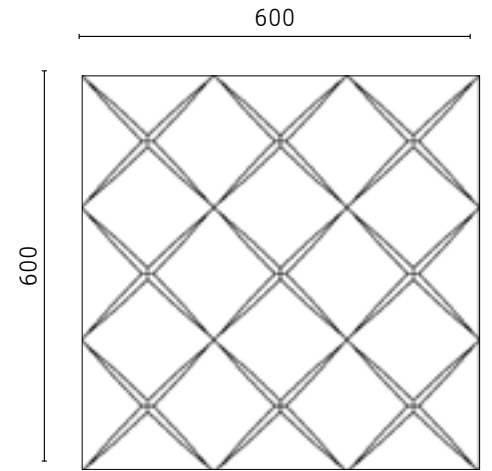

Adamantem

Size: 600x600 mm

Thickness: 15/4 mm

Material:

- American Walnut
- Nacre

Finish: Smooth surface, transparent varnish 25 gloss

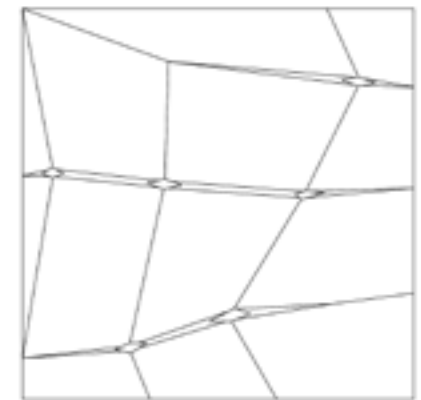
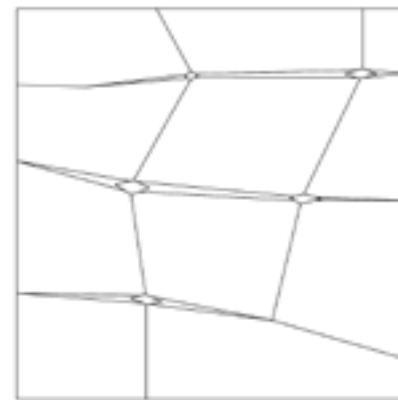
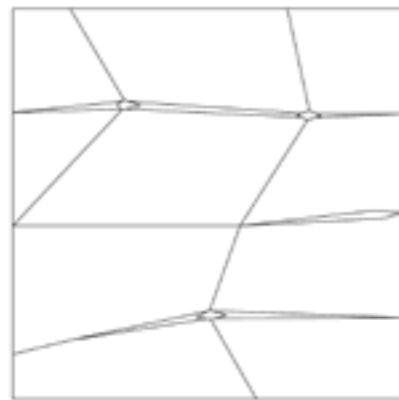
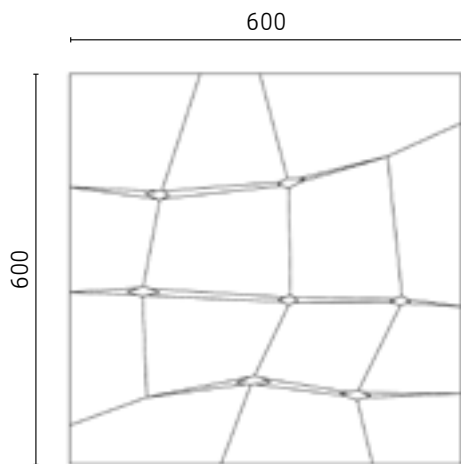
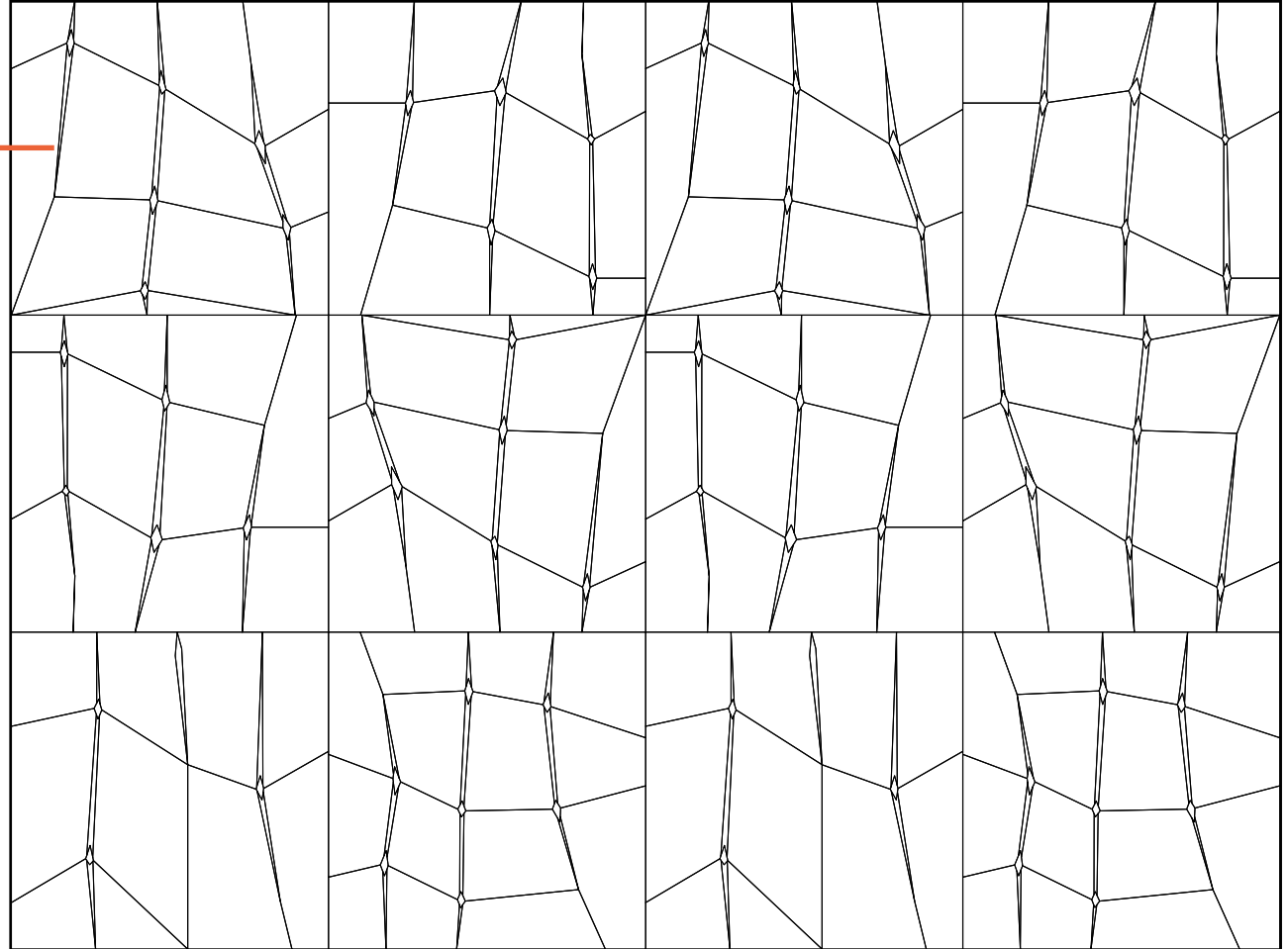



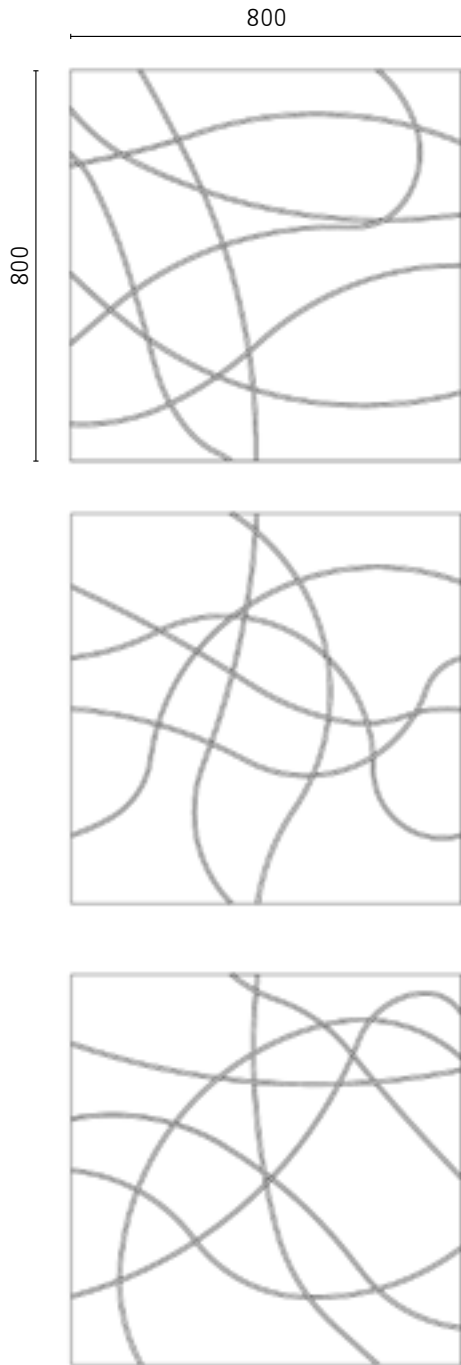

Sinapsi

Size: 800x800 mm

Thickness: 15/4 mm

Material:

- Oak (Comfort)
- Aluminium
- Copper
- Nacre

Finish: Handmade surface, brushed oak, metals with shiny finish

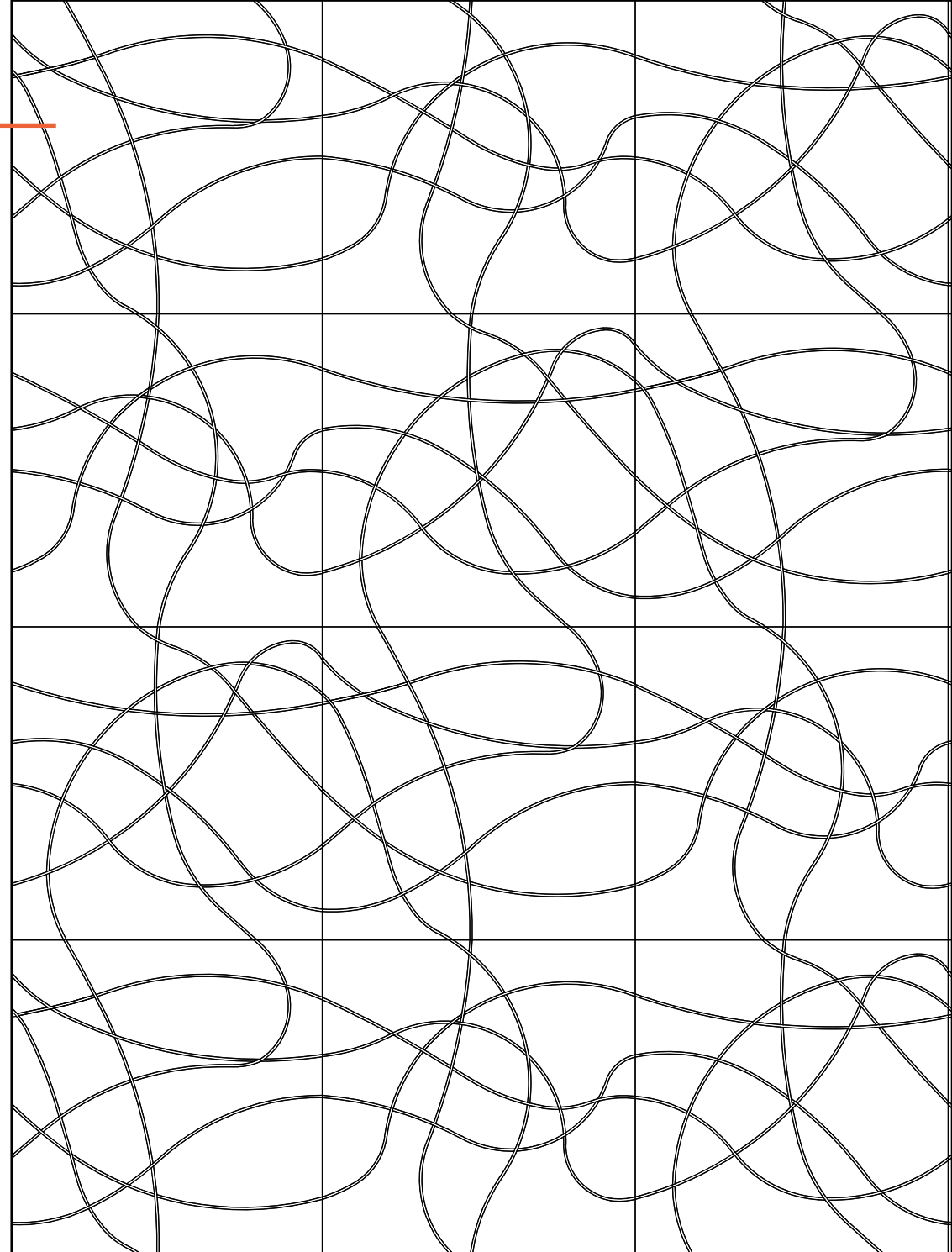



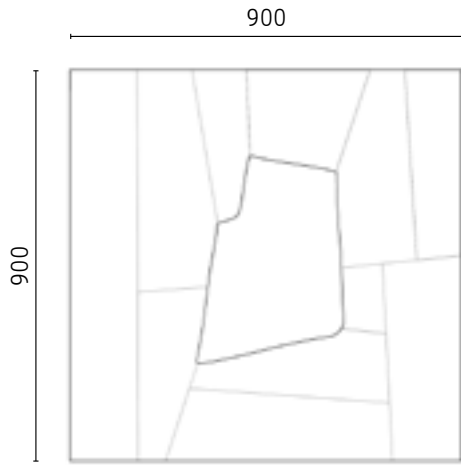

Series Ferreri

Square

Size: 900x900 mm

Thickness: 20/4 mm

Material:

- Larch
- Orobic grey marble (th. 15 mm)

Finish: Sandblast surface, reagent treatment

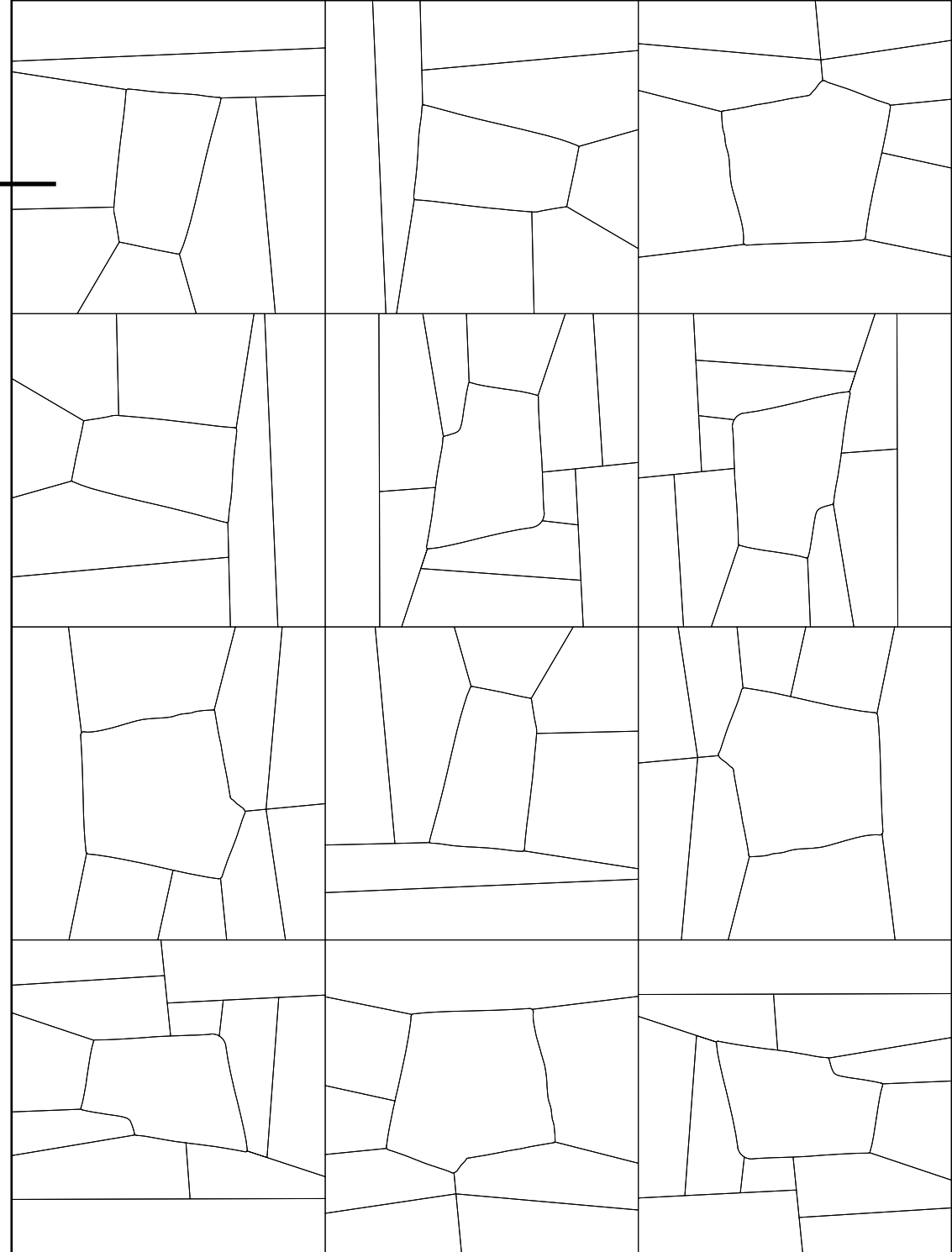
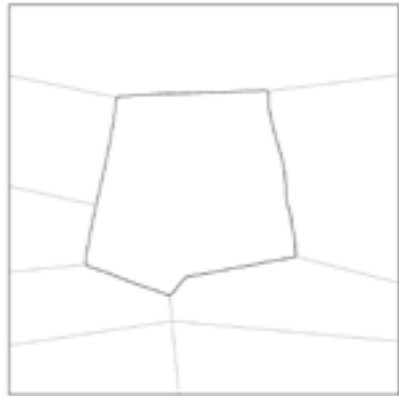





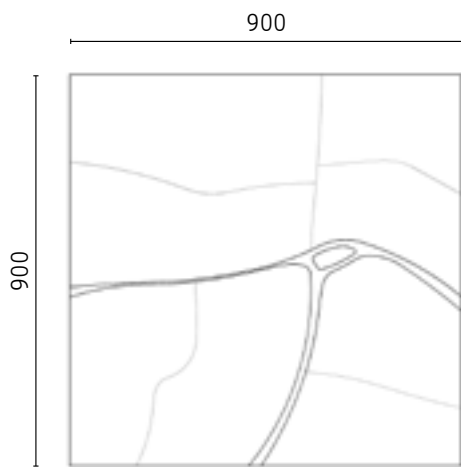

Series Ferreri

Rust

Size: 900x900 mm

Thickness: 20/4 mm

Material:

- Oak (Comfort)
- Iron
- Petrified wood

Finish: Sandblast surface, reagent treatment, iron with rust treatment

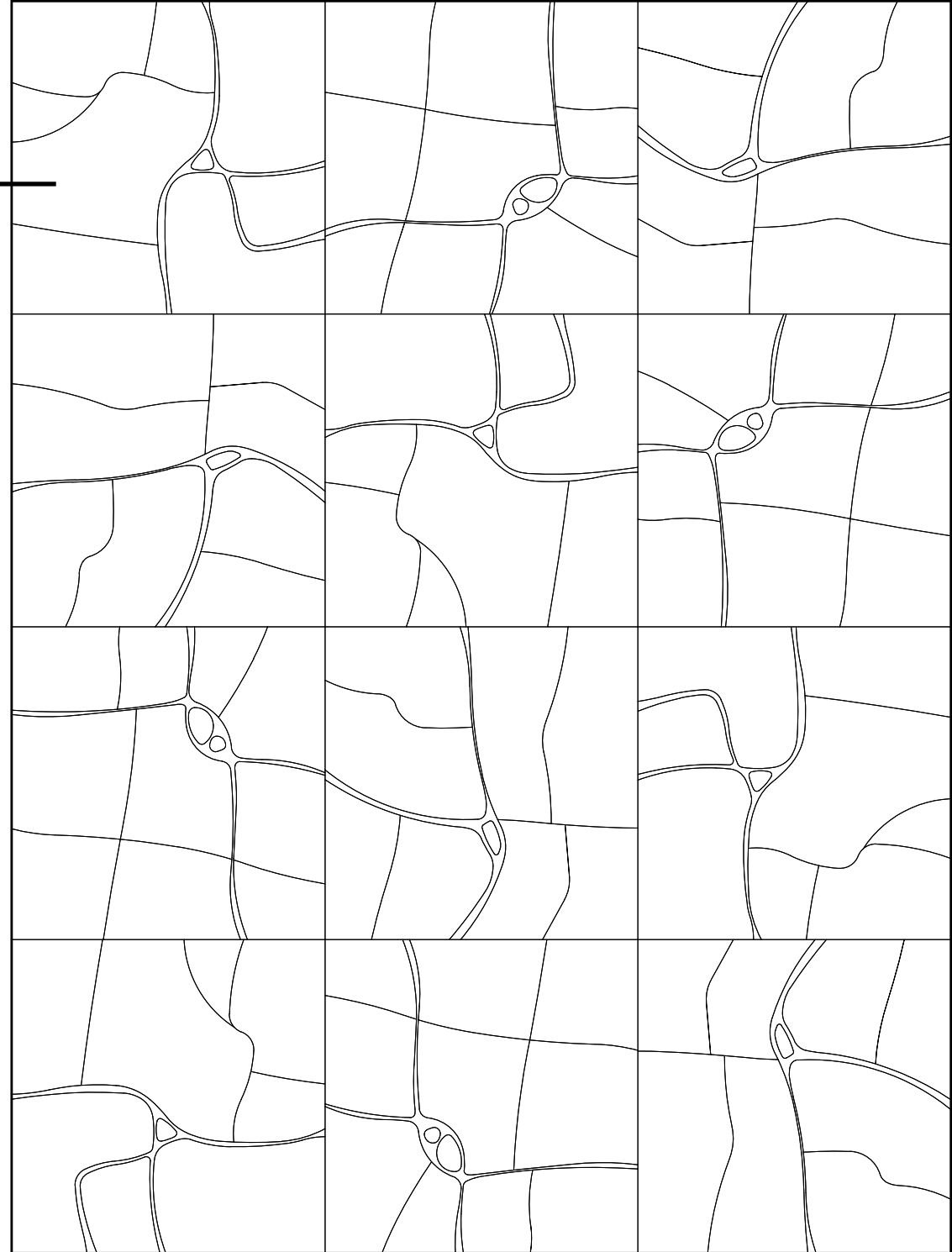



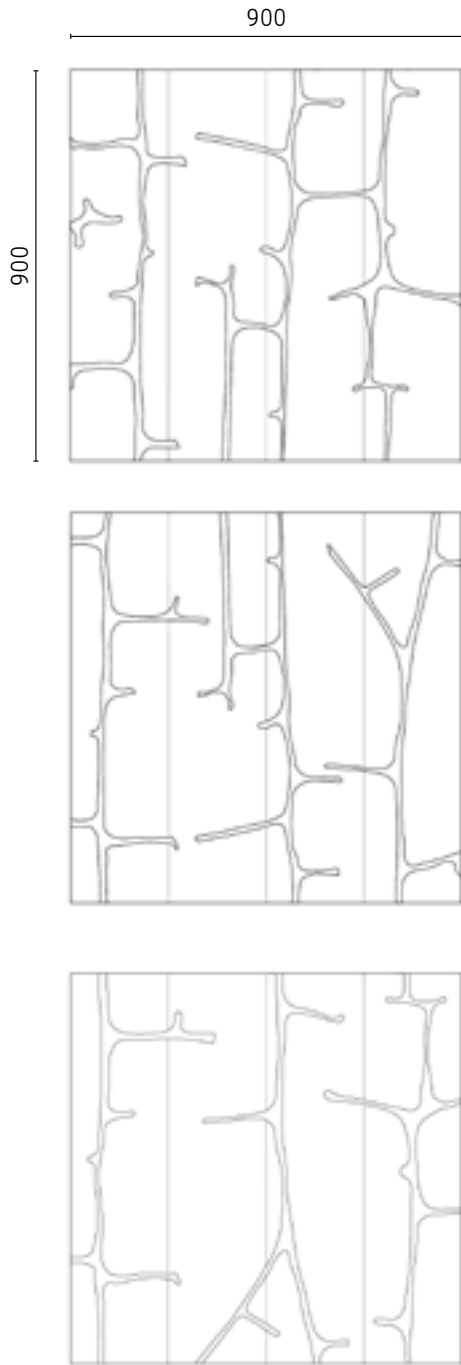

Series Ferreri

Radici

Size: 900x900 mm

Thickness: 15/4 mm

Material:

- American Walnut
- Aluminium

Finish: Sandblast surface, reagent treatment, sandblast aluminium

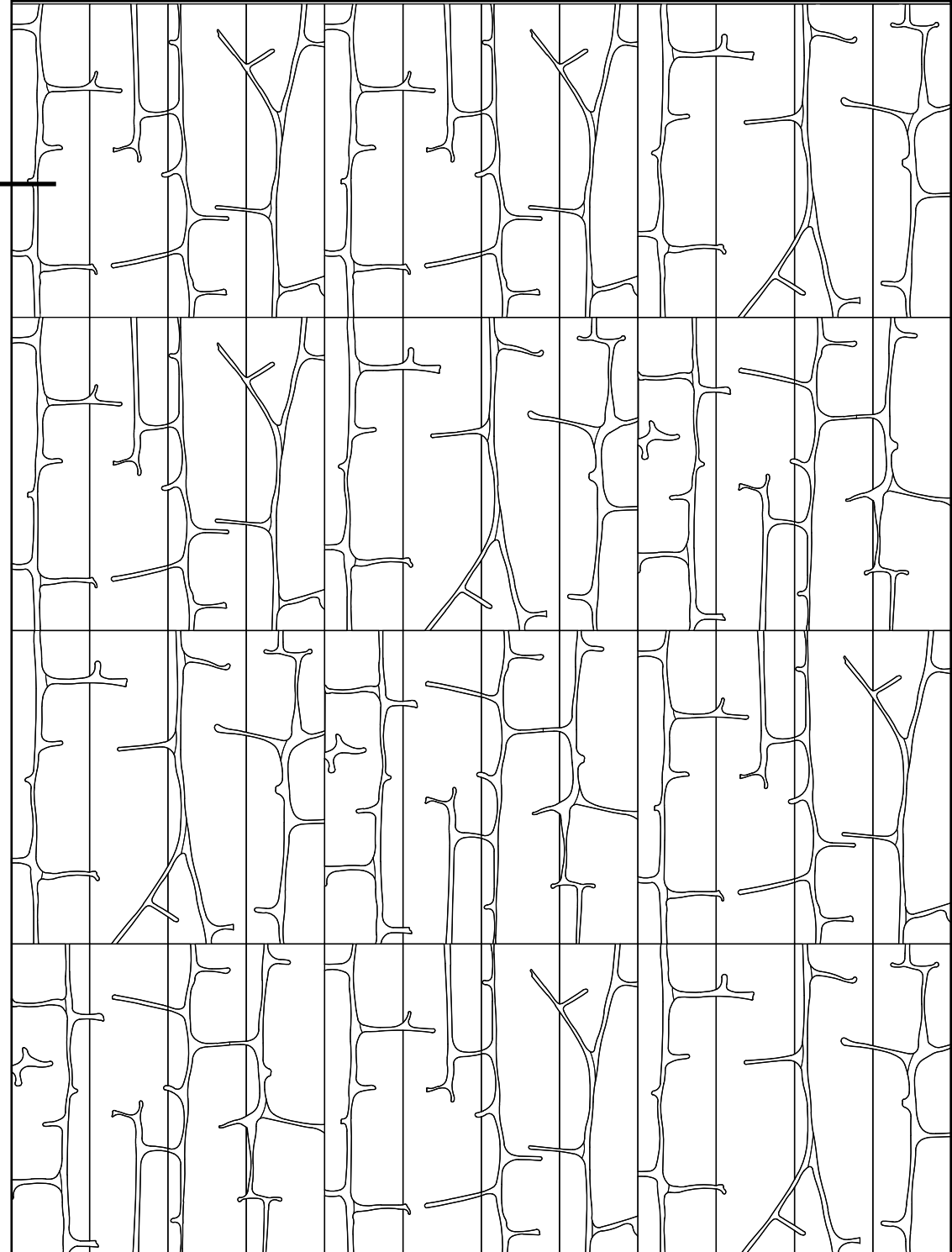





Customized Parquet

Customized parquet

The development of our Customized parquet, includes different stages:

The study of design and materials:



The development of rendering adapted to the layout of the room:



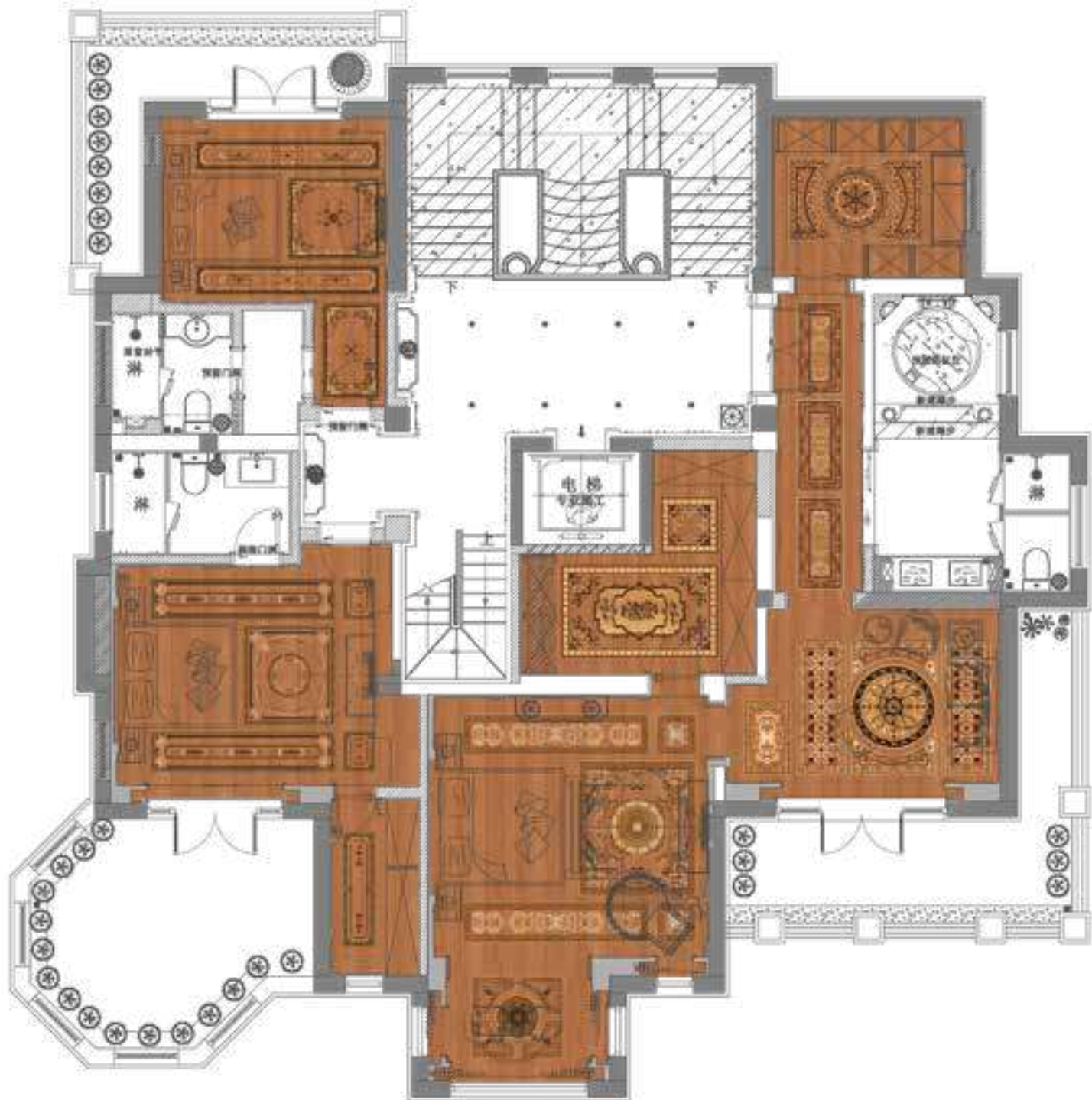

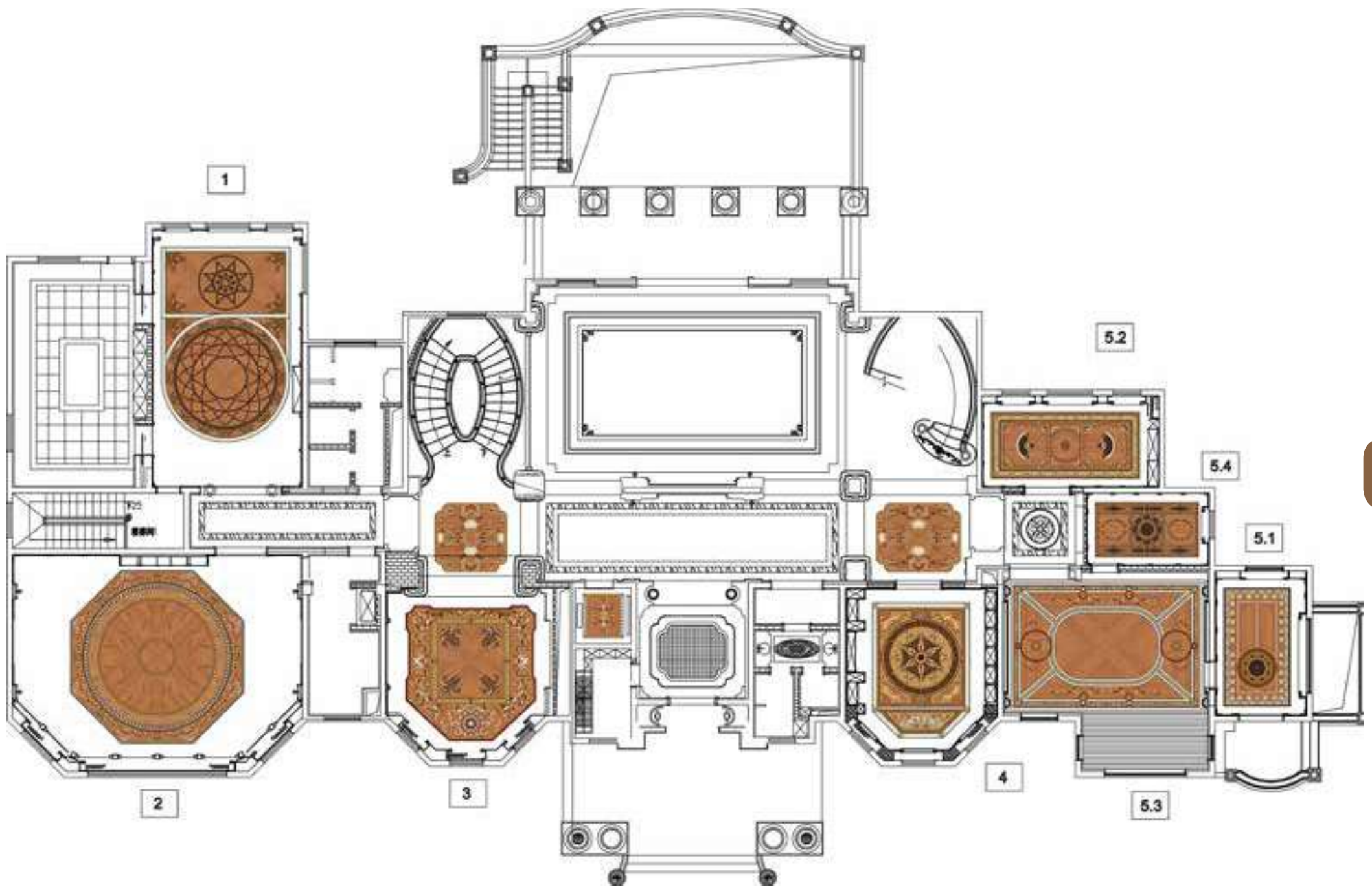

Production and the tests of assembly before the shipment:

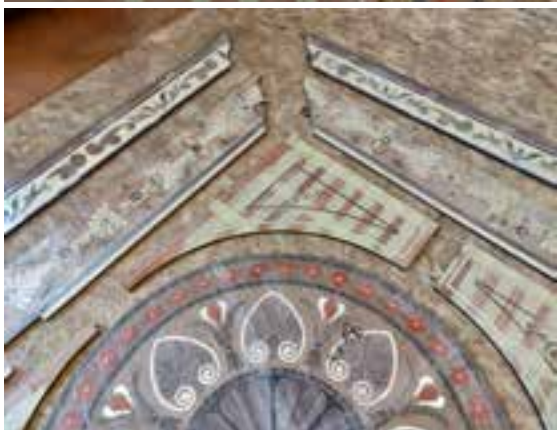

and the numeration of the pieces, in order to facilitate the laying of the floor.

Final results on next page:



The price of this kind of floors is variable, according to the complexity of the decorations and the type of material used. For this reason we recommend to ask to our technical and sales dept. for a proper quotation.

Type 01



Type 02



Type 03

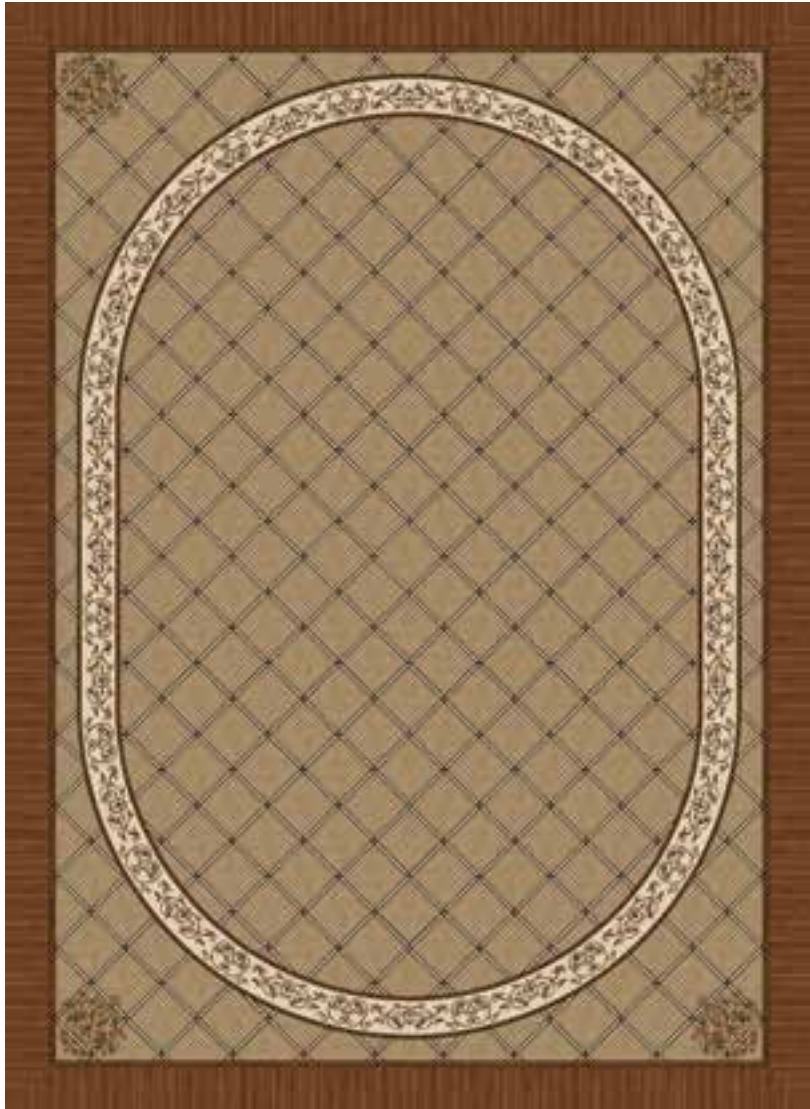

Type 04

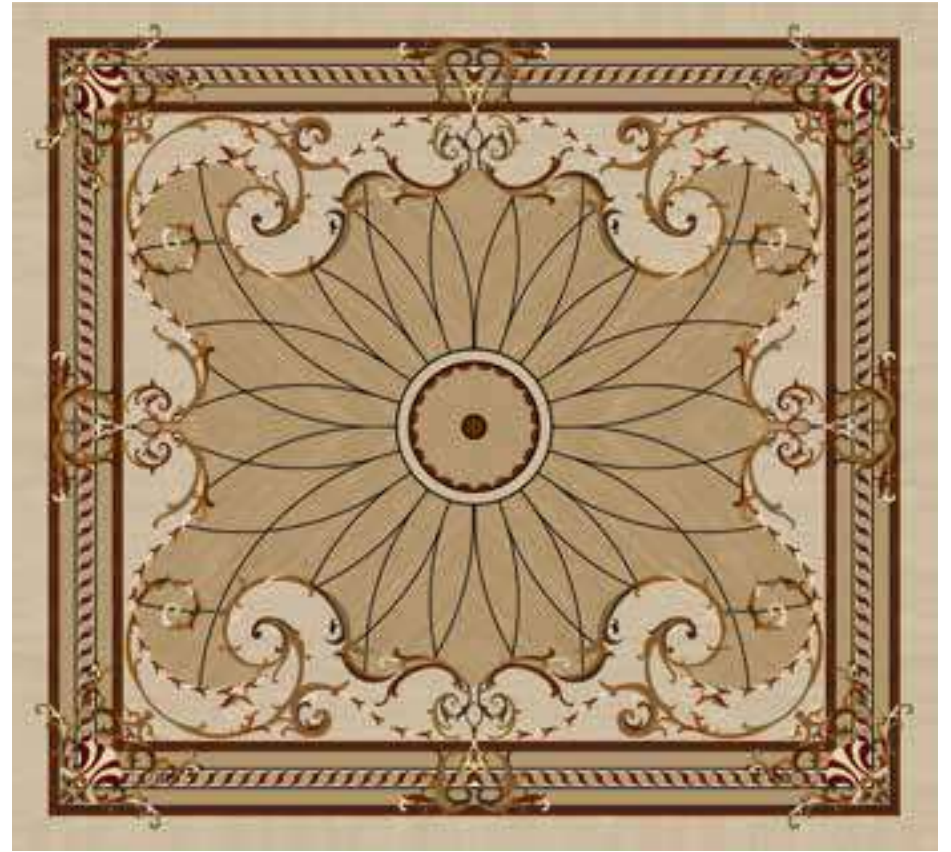

Series Helios





Helios

We introduce the Helios family.

Helios is the Sun around which the solar system rotates and here it manifests itself as a metaphor for man. This metaphor aims to explain the concept behind the new collections, whose centre is the person. We wanted to create surfaces that the customer could customize according to its taste and feel fully represented. The customer will receive a complete package that can possibly cover the entire surface of the house. Those who contact us will find not only particular floors, but also boards or chevrons.

We have deliberately chosen neutral tones because the protagonist of the house should not be the floor, but the personality of those who live in it. Each collection can be customized by modifying the essence of the wood, or by adding inlays of other materials.

Venus

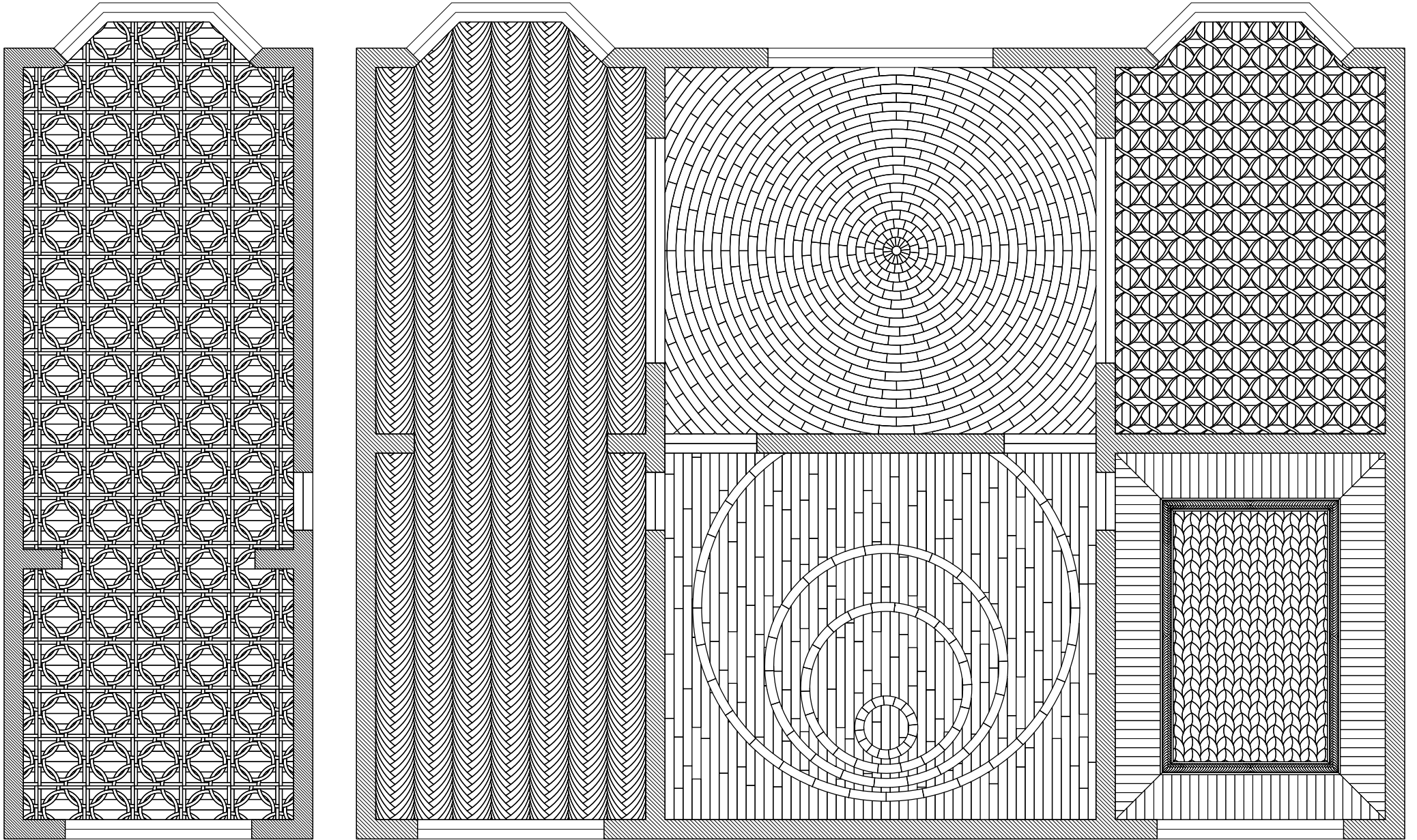

Cosmo

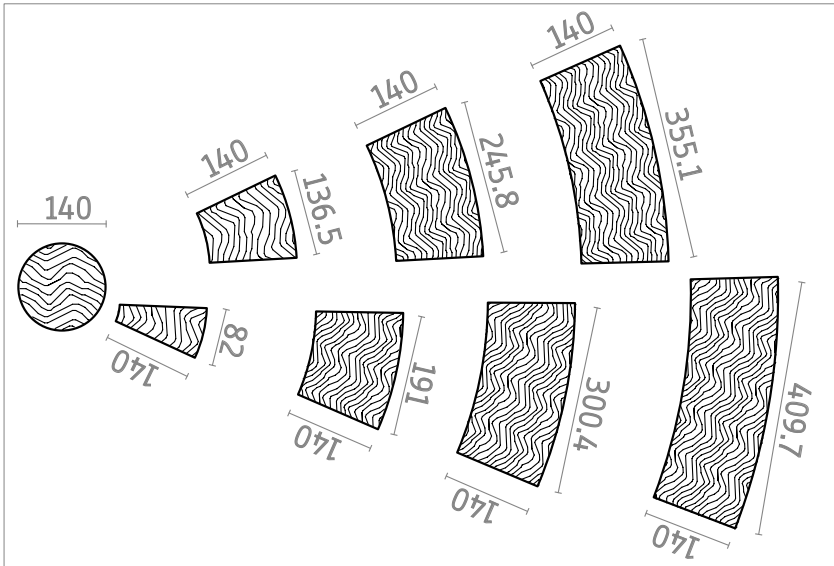
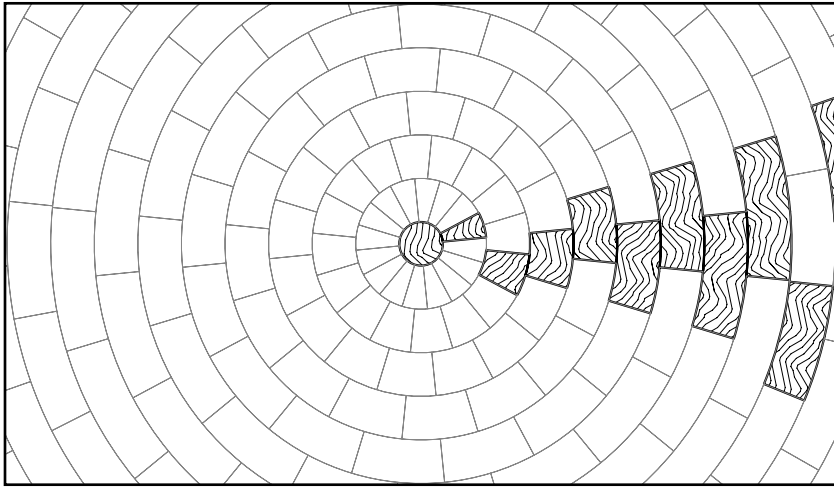

Ask to our technical dept. to modify the design in order to fit it into your room. They will provide all details and a personalised quotation.

Venus Tile

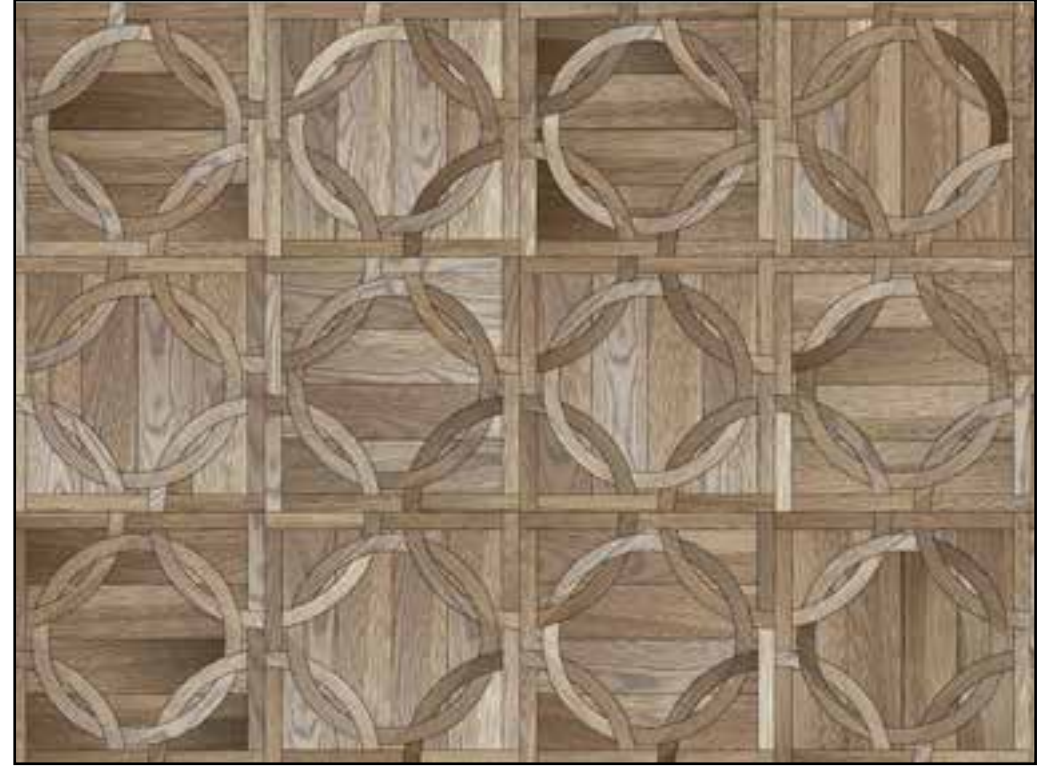
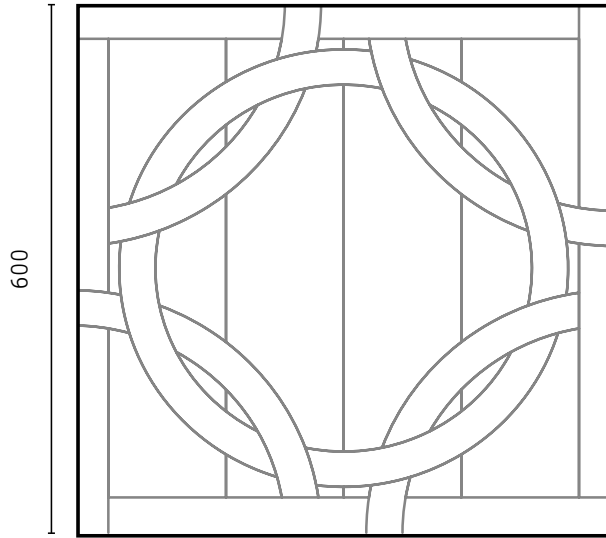

Venus Herringbone

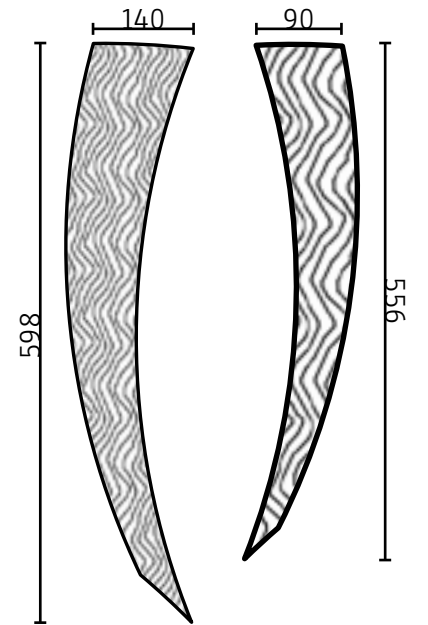





Venus Weave

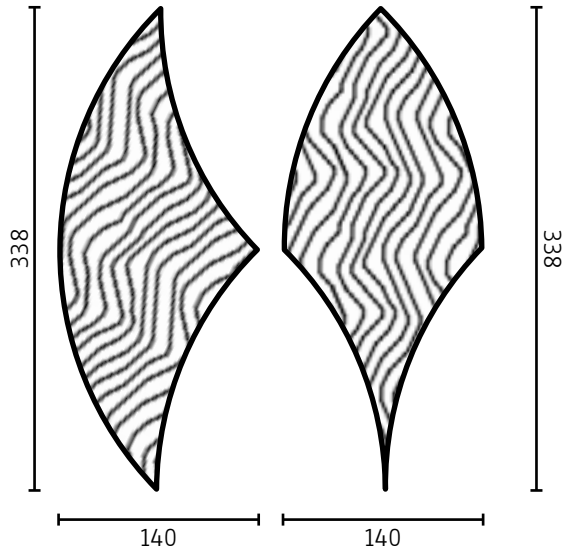

Venus Module

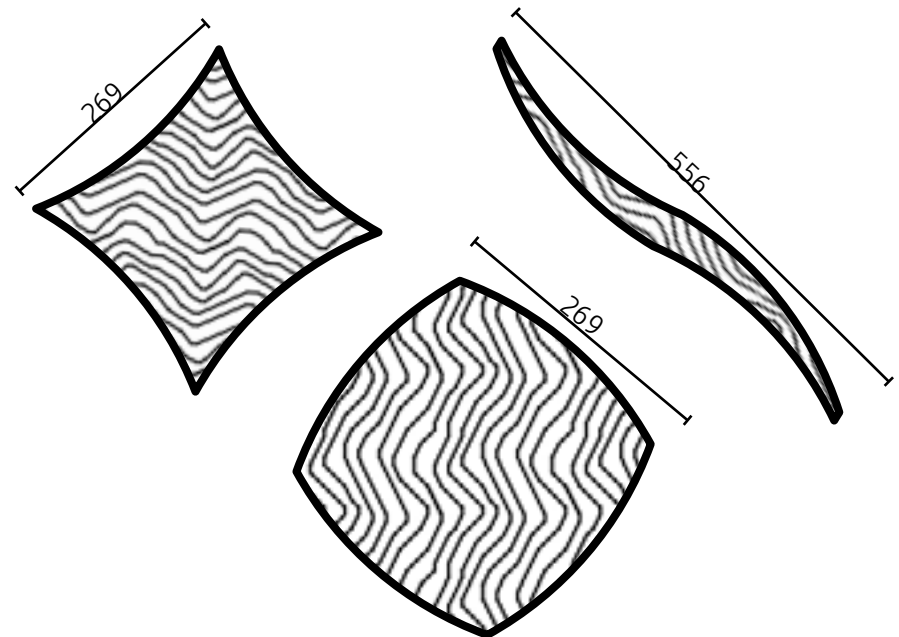

Venus Edge

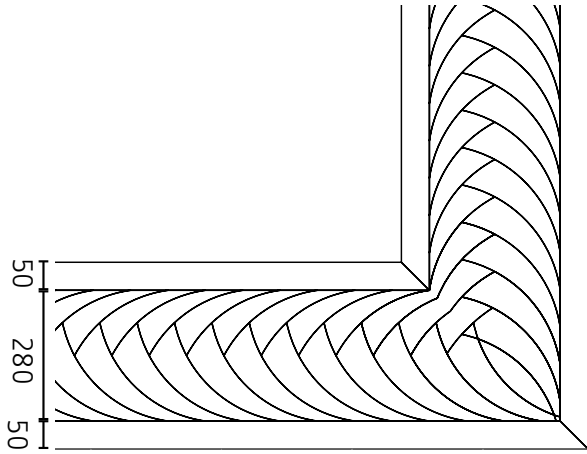

Central Elements

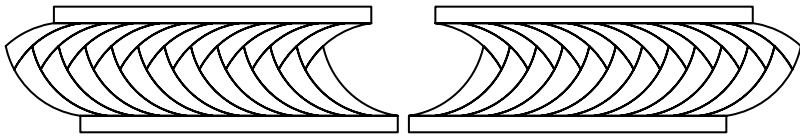

Corners

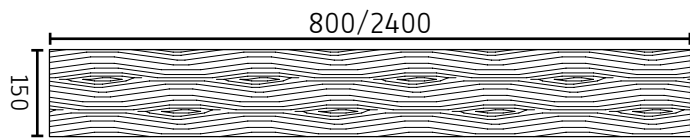
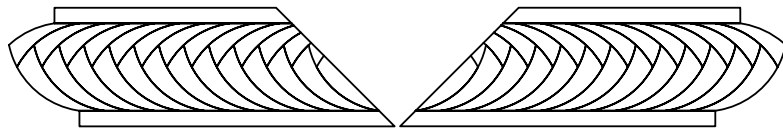

Venus Parquet



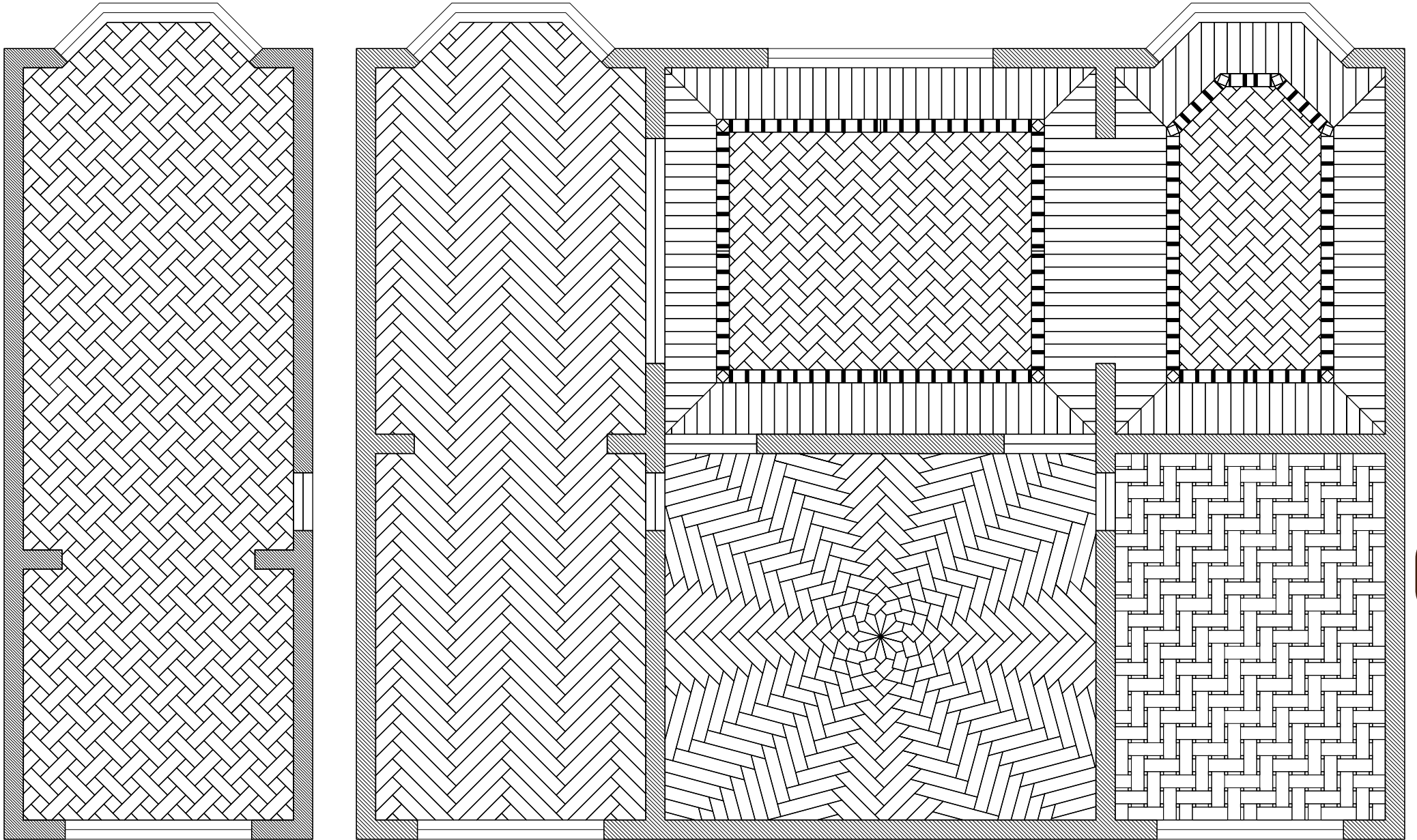

Gea Weave

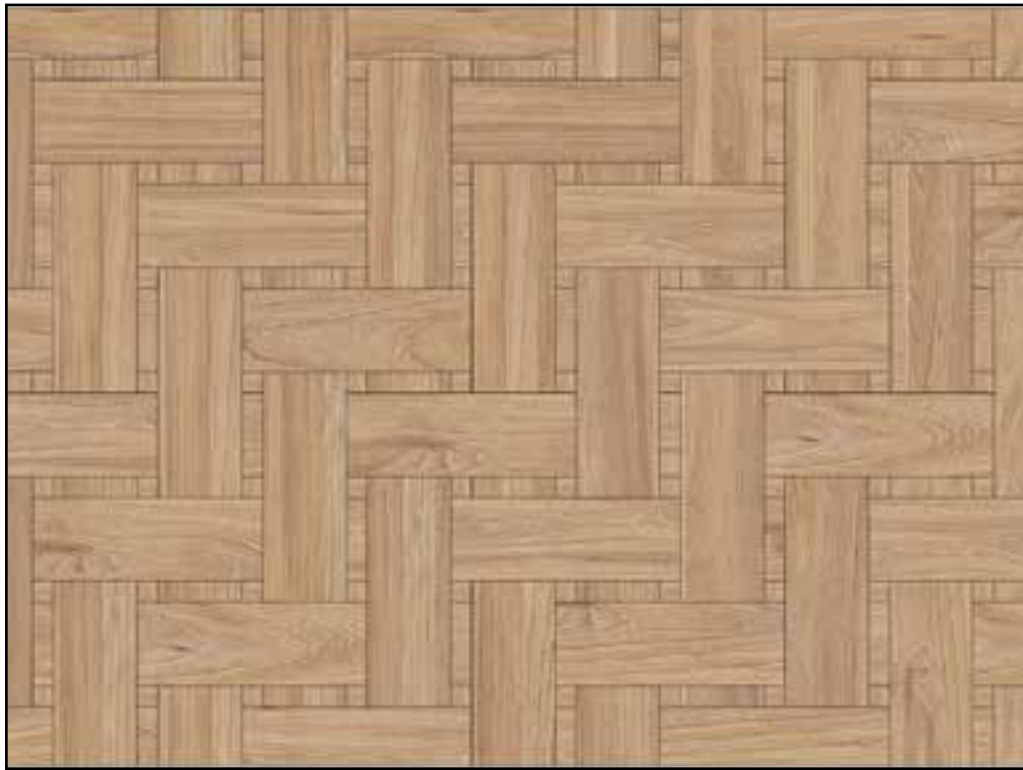
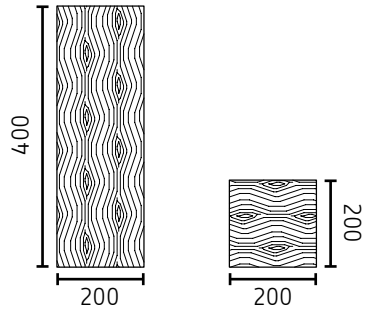

Gea Module

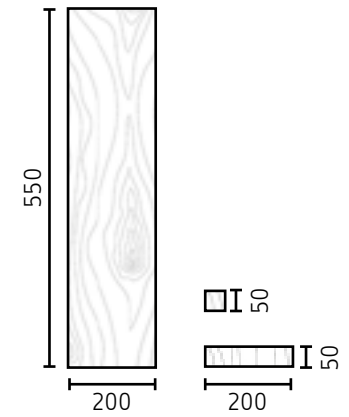

Gea short Herringbone

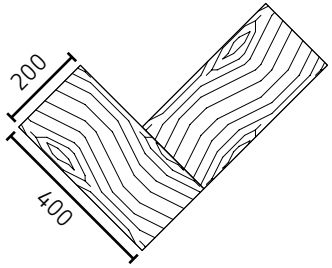

Gea Herringbone

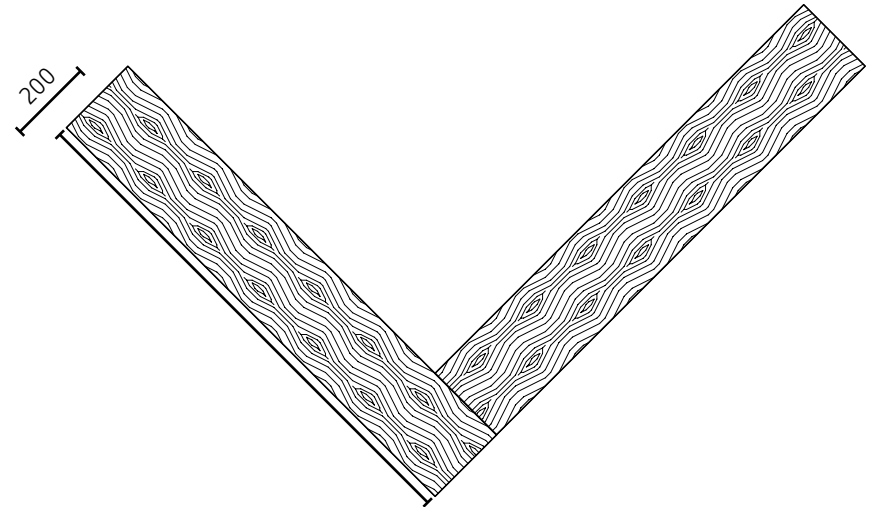

Gea Parquet

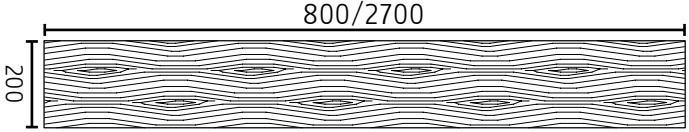

Gea Edge

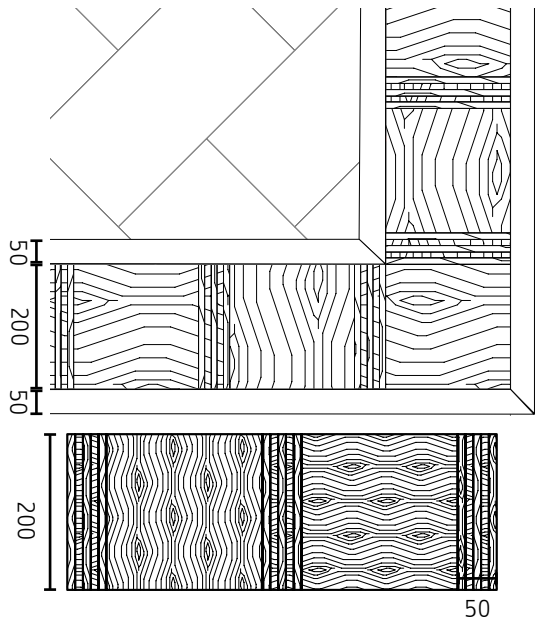

Kronos

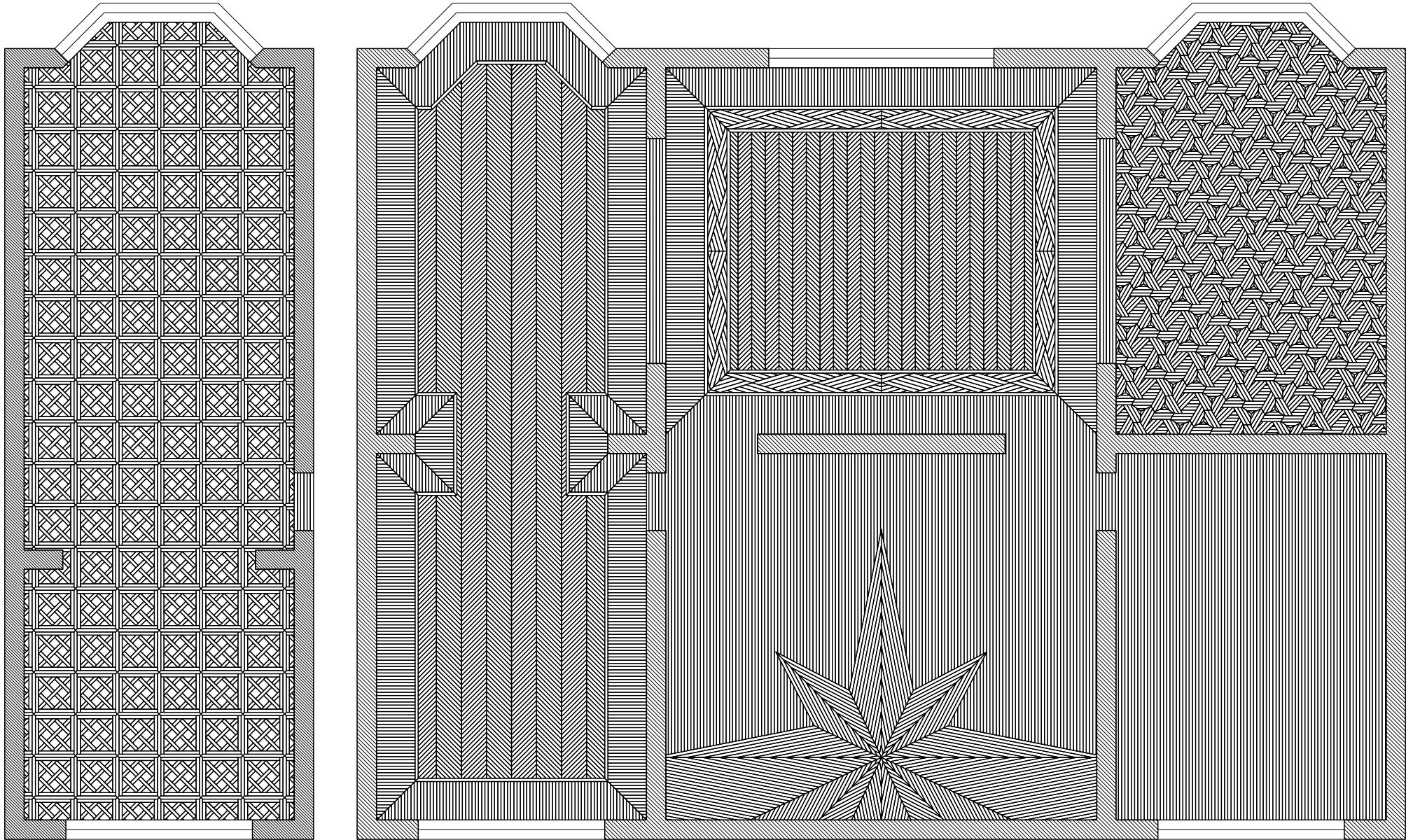

Stella

KR1

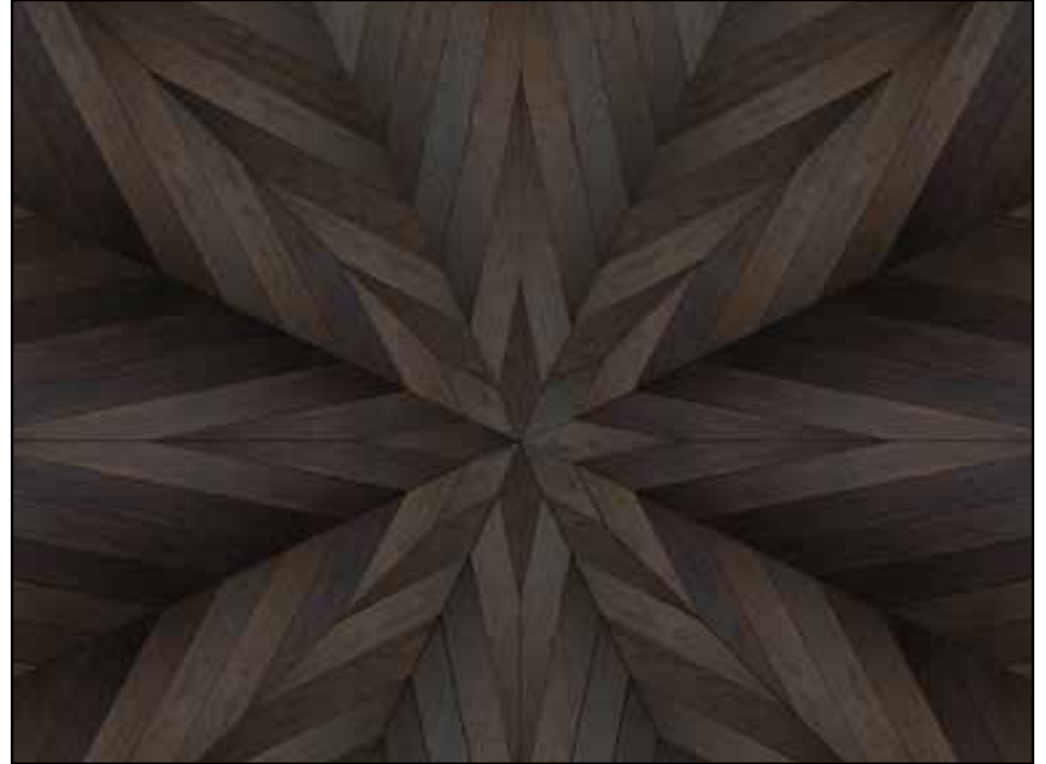
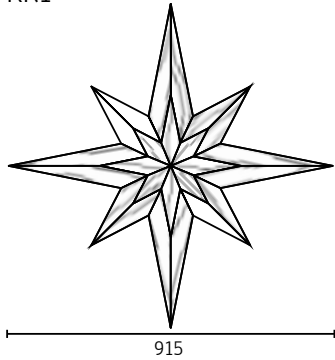

KR3

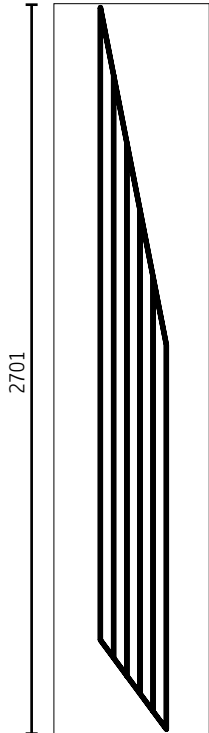

KR2

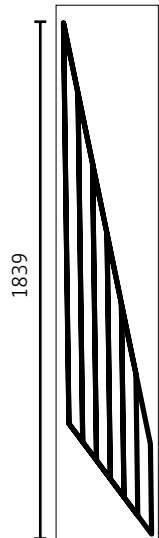

KR5

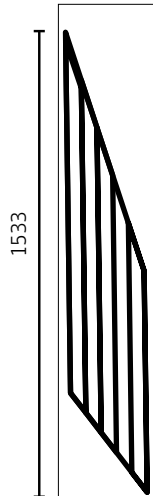

KR4

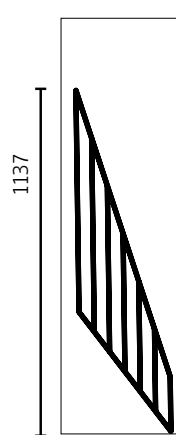

Depending on the dimension of the room, you can use all or a part of the panels. In this way you will obtain a bigger or smaller Star. We can always personalize the design, just ask to our Technical dept for more information.

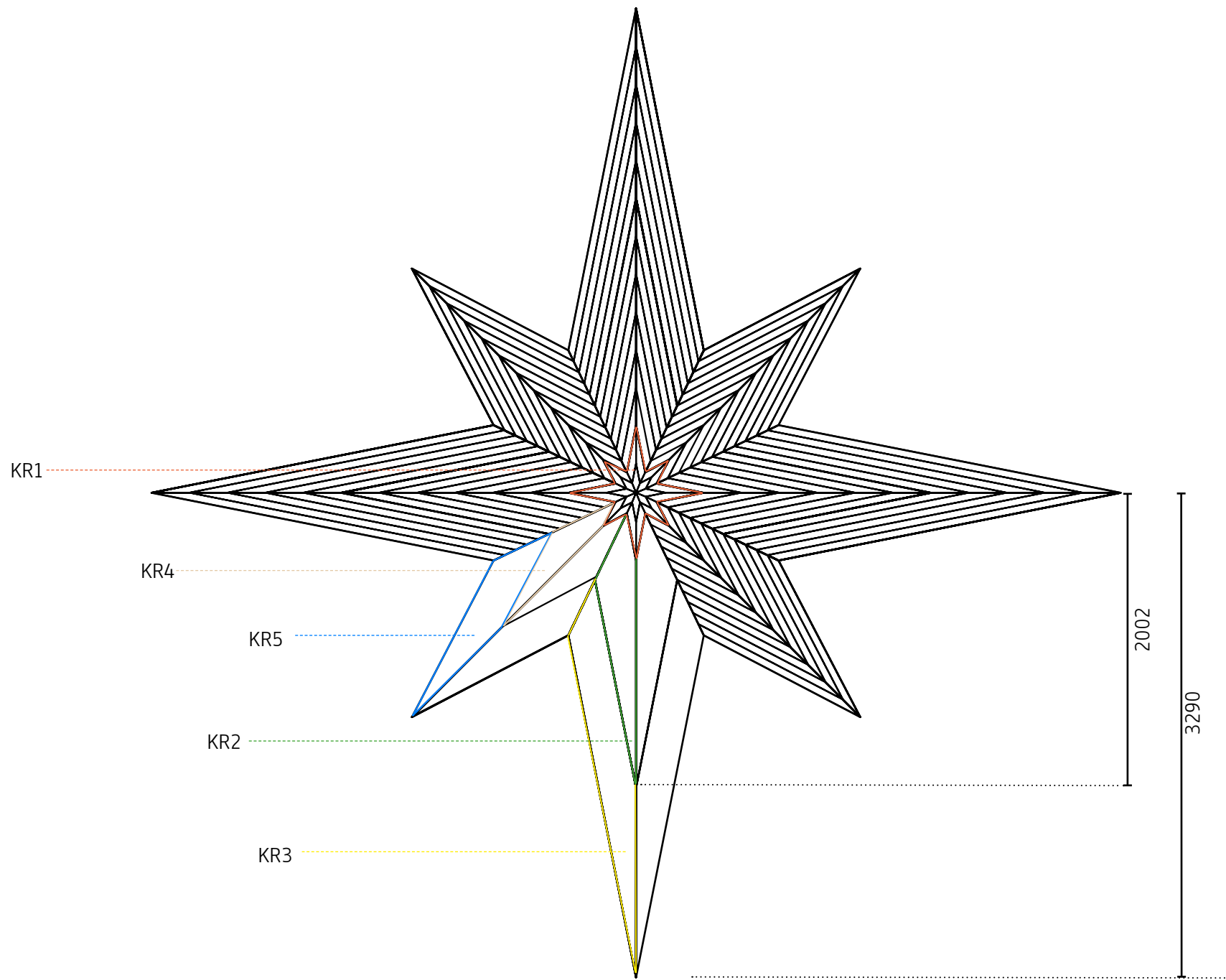

Tile Kronos

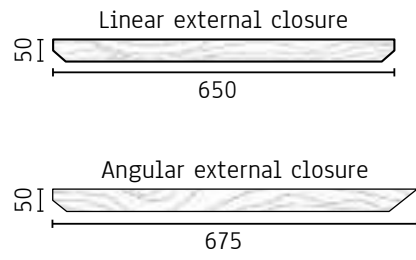
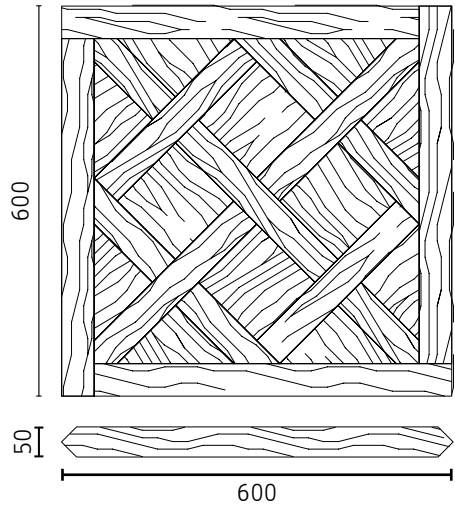



Kronos Slim Chevron

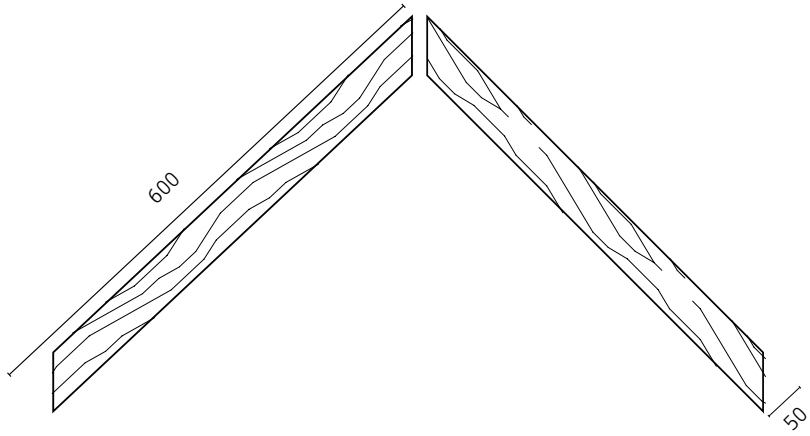

Kronos Short Chevron

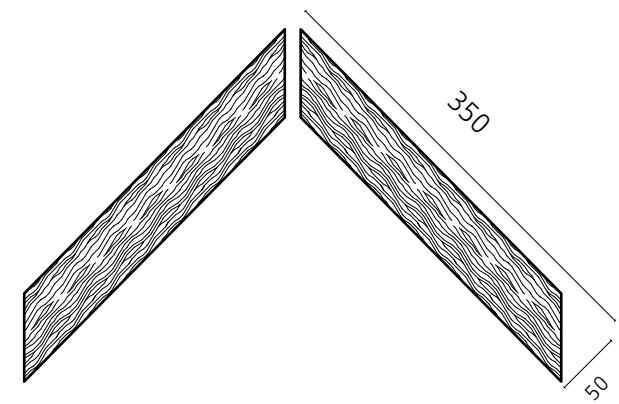



Kronos Module

BIG

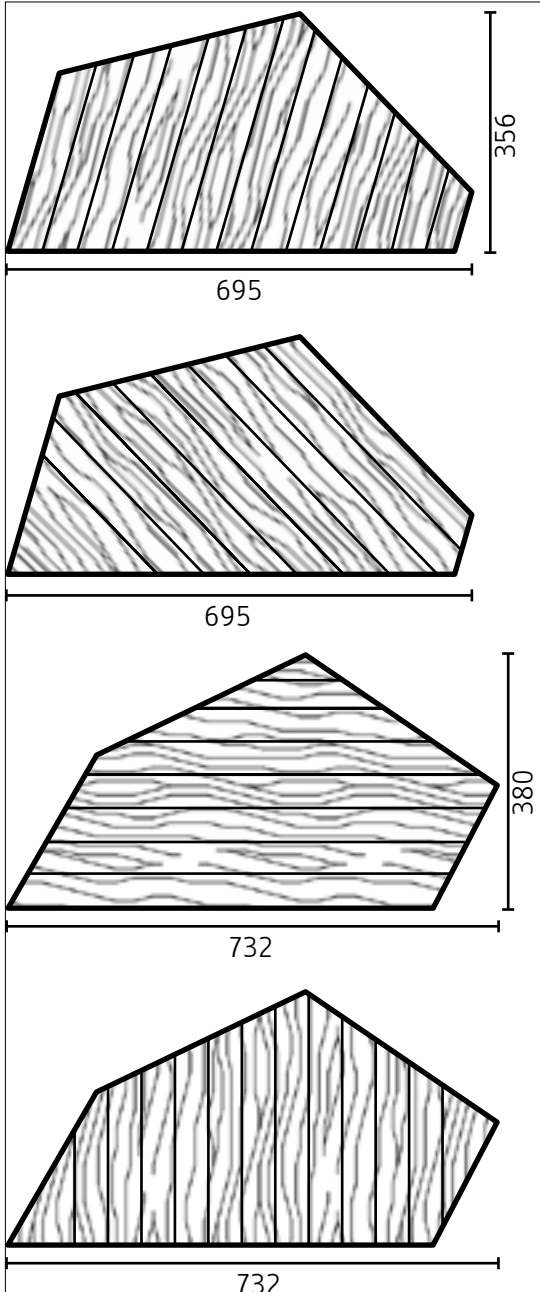

SMALL

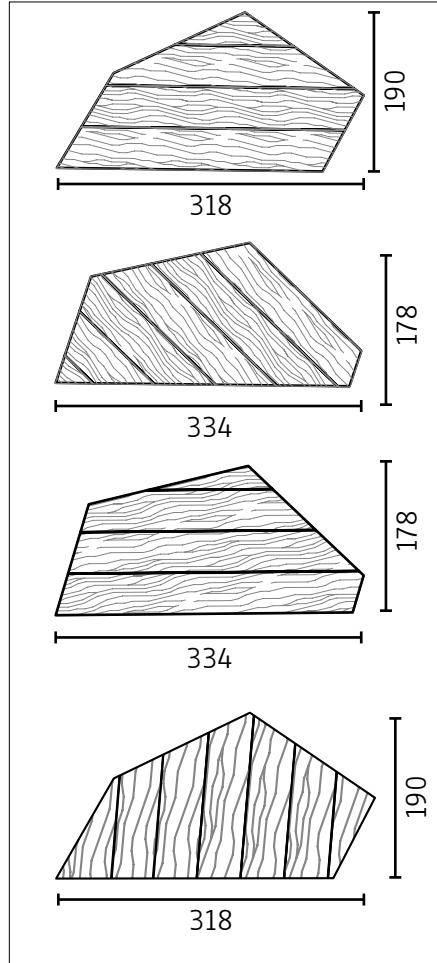

Kronos Parquet

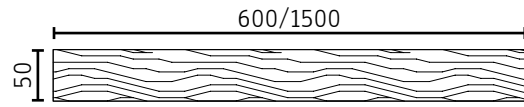

Kronos Edge

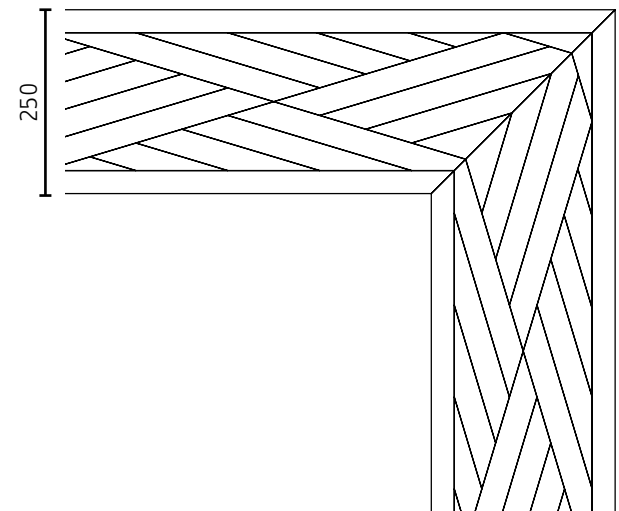



Surface treatments

Smooth surface

Treatment that involves a very fine sanding that makes the surface smooth and uniform.



Brushes surface

The surface is worked through the use of brushes that remove the softer part of the grain and highlight the heartwood of the fiber. The result is a natural and pleasant effect.



Sawn surface

The saw cut applied to the surface leaves irregular deep traces on the wood. The roughness gives to the floor an artisanal look.



Hand planed surface

In the past, sanding was carried out with the use of planes. Today we propose the traditional hand planing process to give our surfaces a rustic look and an antique flavor.



Soft Touch surface

A treatment that offers a tactile sensory experience through the irregular surface processed by hand. We create a "rounded effect" that accompanies the lines of the design, making the floor irregular and enhancing its texture.



Finishes

Standard tint varnishes for our wooden surfaces:



Finishes

For our wooden surface, we offers a wide range of finishes:

- Acrylic transparent varnish - matt
- Acrylic transparent varnish - standard (10-25 gloss)
- Acrylic transparent varnish - shiny (30-60 gloss)
- Tint varnished
- Treatment with reagent
- Smoked treatment on surface (only oak)
- Thermo treatment (only oak)



If you wish a more refined finish, we offer a wide selection of finishes that are made using natural components of the wood. These finishes are 100% *ecofriendly* and they highlight the natural beauty of the wood.

Certifications



Il marchio della gestione
forestale responsabile
FSC® C167755

Important

If FSC certification is required, it's very important to specify it at the moment of the request for a quotation.

FSC materials is not always available, therefore time and price for the purchase of certificated raw materials can be defferent depending on the quantity needed.

Recommandation for the maintenance of parquet

Varnished Surfaces

Dirt is the main cause of wear on wooden floors, for this reason adequate and periodic cleaning of the surface is needed. Wood is a living material and as such it should be treated. Significant changes in temperature and humidity can alter the structure of the floor (expansion in case of a humid climate or fissures in case of dry climate).

MAINTENANCE STAGES

To maintain a varnished wooden floor in excellent condition we recommend to:

- Daily remove dust and impurities on the floor by sweeping with a broom or a vacuum cleaner equipped with a delicate brush. Do this operation frequently since dust, sand and soil accelerate the process of wear of wooden floor
- Clean the floor regularly every 15-30 days with a damp cloth, accurately wrung out, soaked with water and natural soap. Avoid to use too much water during the cleaning, since this could damage the floor. Do not use water without soap.
- Periodically, if the floor looks opaque or dull, use a revitalizing or self-polishing wax for parquet, which help to restore or "hide" small scratches. Carry out this treatment at least once a year in areas with intense foot traffic.

MAINTENANCE RECOMMENDATION

- Always clean the parquet in the laying direction. This helps detergent and water to act more deeply without ruining the wood.
- Use neutral products. Too-aggressive and non-specific products could damage the floor.
- Never use ammonia, vinegar or foamy detergents for cleaning.
- Use a doormat at the entrance to reduce dirty and impurity that can scratch the surface. For the same reason position felts under furniture and chairs.

Oiled Surfaces

For the oiled surfaces you can use the same recommendation. In addition:

- Periodically, if the floor looks opaque or dull, use a revitalizing or self-polishing wax for parquet or a specific oil for maintenance, which help to restore or "hide" small scratches. Carry out this treatment at least once a year in areas with intense foot traffic.

Products for the treatment of parquet

For the cleaning of varnished or oiled surfaces



EMERALD is a neutral polishing sanitizing detergent suitable for all washable surfaces. This product is made using raw materials of vegetable origin and ECOCERT and RSPO certified surfactants. It removes dirt, sanitizes and degreases without leaving streaks and preventing the formation of mold, bacteria and pathogenic germs. Thanks to its delicate but incisive cleaning action, it is particularly suitable for wooden surfaces. Lt. 1

Recommended for the maintenance of varnished surfaces



DIAMOND is a new concept wax which, thanks to its components releases nourishment and protection to varnished parquet, preserving it from wear and dirt. It is self-polishing protective product that restores the original shine of a varnished parquet, realising a pleasant scent into the environment. Diamond is available in two versions, "Shiny" and "Satin" depending on the existing finish. Lt. 1

Recommended for the maintenance of oiled surfaces



GEM is a natural oil wax in water solution to be used as a maintener of oiled wooden floors, to nourish and protect the wood. Gem is a product based on natural elements (such as sunflower oil, beeswax and propolis) and does not emit harmful substances. Its formula enhances and gives protection to oiled surfaces, increasing their stain-resistant properties. Lt. 1

General sales conditions

PREMISE

These General Conditions of Sale, except for any written exceptions specifically approved by the parties, govern all sales contracts between La Brenta S.r.l. (hereinafter Seller) and the customer (hereinafter Buyer). The single sales contract between the parties is also governed by the Special Conditions of Sale agreed from time to time between the Seller and the Buyer and which will be the subject of a supplementary agreement signed by the parties.

- 1) ORDERS: All order proposals and offers must be the subject of an order confirmation or a written contract accepted by the Seller and the Buyer.
- 2) VALIDITY: The sale proposal will become executive starting from the date of receipt of the order confirmation and will be modifiable for a period of 24 hours from receipt of the same. After these 24 hours, we will proceed with the work as indicated in the order confirmation and in the attached construction sheets or, failing that, in the technical documentation in force at the time of the order. All written or verbal agreements agreed upon in the order proposal phase will become executive only if referred to in the order confirmation. Any transmission or additional purchase order implies, without the need for further formalities of any kind, the complete adherence to the general conditions of sale reported here. Unless otherwise agreed between the parties, in the event of cancellation of the order by the Purchaser when the material processing has already begun, he will have to pay all the costs incurred to execute the contract, without prejudice to the greater sum due as compensation for damages.
- 3) SALE PRICES: The prices indicated are tax free, Ex Works and include standard packaging (see point 7). In case of improved packaging, the price will be explicitly expressed. If before the delivery of the goods there have been increases in the cost of labour or raw materials, including freight rates, transport, customs duties and currency exchange, the Seller will have the right to revise the price to the extent corresponding to the extent and incidence of the aforementioned increases, without prejudice to the Purchaser's right to withdraw from the contract if said increases prove to be too burdensome for him, with his waiver in any case of any claim for damages or other claims against the Seller. It will be the customer's responsibility to send the documentation relating to any reduced VAT rates, which must reach the Company within 5 days from the date of this.
- 4) DELIVERY: The delivery terms are intended in principle and barring unforeseen circumstances, will run from the date of receipt of the order confirmation signed by the Buyer or by a person authorized by him, or in any case tacitly approved pursuant to art. 1. By way of non-exhaustive example, unforeseen events are:
 - insufficiency of technical data, inaccuracies and delays on the part of the Purchaser, in transmitting information or data necessary for the fulfilment of the order;
 - supply difficulties; total or partial strikes, lack of motive power, storms, mobilizations, epidemics and any other fortuitous cause or force majeure;
 - negative commercial information arising during the preparation of the goods;
 - change in ownership of the Purchasing company.

The Buyer is not entitled to any penalty or compensation of any kind, neither in the event of delivery delays, nor in the case of split deliveries as the delivery terms are merely indicative as they are determined on estimated production times. The Seller will not incur any responsibility for the realization and / or shipment of goods after the agreed term.

- 5) TRANSPORT: Unless specific agreements between the parties, the agreed prices refer to the goods delivered ex-Saccolongo, loaded on trucks (Ex Works). The goods travel in any case at the risk and peril of the Buyer, who bears the costs of transport, unloading and insurance, where required. Unless otherwise expressly agreed, the means of transport will be chosen at the discretion of the Seller. The Purchaser must guarantee suitable access to the site to normal means of transport, meaning by the term "normal" all vehicles traveling on roads and motorways without the need for special authorizations. The Purchaser is responsible for all the acts and formalities necessary to ascertain any damage in shipping, packaging, etc., which, regardless of the person responsible for the compensation, must be communicated and documented by pec to the Seller within 3 days of delivery. The Seller is also relieved of any and all liability for damage suffered by unpackaged traveling goods, damage that may be caused by incorrect maneuvers of the carrier, overturning, transshipments, etc.

If the transport was at our care, if the destiny of the material was in a limited traffic area (ZTL), it must be the customer's responsibility to provide all the necessary authorizations. Otherwise, the transport will be at the expense and care of the customer.

- 6) FAILURE TO COLLECT THE GOODS: After 15 days from the date of notice of the goods ready, the Seller will be entitled to invoicing, with the contractual payment deadlines, in addition to an indemnity, equal to 2% of the price of the goods themselves, for each month of delayed collection. The goods may be placed, by the Seller and at the Buyer's expense, in the production plant, stacked separately, or in a warehouse of the Seller's choice, giving notice to the Buyer. With this the goods will be understood as identified for the purposes of art. 1378 and 1465 of the Italian Civil Code and to any other law. In case of non-acceptance and return of the goods for reasons not related to the quality of the goods shipped, all costs related to transport from the factory both to destination and to the return will be fully borne by the Buyer. In addition, the Seller will have the right to invoice the amount relating to the same, ipso jure terminates the Contract and sell the uncollected Products in the best possible way, without prejudice to the right to compensation for greater damage. In any case, the Purchaser is responsible for parking costs and any other charges and responsibilities for the storage and custody of the Products if necessary.

- 7) RIGHT OF WITHDRAWAL: In compliance with the provisions of the Consumer Code, as amended by Legislative Decree no. 21/2014, the Customer who holds the quality of consumer and, therefore, the natural person acting for purposes unrelated to professional activity, has the right to withdraw from the purchase contract within and no later than fourteen days from delivery, or from day on which the Customer himself or a third party designated by the latter acquires physical possession of the purchased goods. The conditions and procedure for exercising this right will be specified in the following paragraphs.

The Customer who intends to exercise the right of withdrawal must communicate by ordinary mail, registered mail, electronic mail, fax, or any other form of communication, his will to exercise the right of withdrawal, within the terms established by law. The Seller, having received the declaration of withdrawal, will send the Customer a confirmation email. To complete the withdrawal procedure, the Customer can entrust the goods to a courier of his choice. The shipping costs for the return of the goods to the Seller will be charged to the Customer.

The Customer must send the goods, carefully packed in the original packaging, via the indicated courier, to the following address:

La Brenta S.r.l.
Via L. Einaudi 70
35030 Saccolongo (PD), Italy

The shipment of the goods to be returned must take place no later than 14 days from the date on which the Customer communicated to the Seller the decision to withdraw from the purchase contract.

The Seller, in compliance with the provisions of art. 56 of Legislative Decree n. 21/2014, once verified compliance with the conditions referred to in paragraph 4, will refund the customer the cost of the product within 14 days of receiving the notice of withdrawal, without prejudice to the right to withhold the refund until the date of return of the product at its headquarters or until the date on which the Customer sends proof of actual shipment and delivery of the goods to the courier. The Seller is not required to reimburse additional costs if the Customer has chosen a type of delivery other than the least expensive type of delivery offered ("basic" shipping). The refund will be made by bank transfer.

The right of withdrawal is subject to the following mandatory conditions:

the Customer can exercise the right of withdrawal only and exclusively with regard to the entire product; it will not be possible to exercise withdrawal only on a part of the product.
the purchased product must be returned in its original packaging, complete with all accessories and its documentation;

the product must be returned in perfect condition, products showing signs of damage, wear or dirt will not be accepted;

the returned product must bear the same serial number on the invoice, otherwise, if the serial number is different, the withdrawal will not be accepted and the product will be made available again to the Customer, without any financial refund from the Seller in his regards;

in the event that the Customer decides to return the goods via a courier of his choice, the shipment for the return of the product is under the responsibility of the Customer, until the moment in which the Seller confirms that he has received the product. In the event that the product suffers damage during the return to the warehouses, it will be the Seller's responsibility to communicate the incident to the Customer to allow him to file a complaint against the courier chosen by him and obtain a refund of the value of the goods, if this is insured; therefore, the Seller will make the product available to the Customer, cancelling the withdrawal.

The right of withdrawal lapses if the Customer does not return the goods to the Seller within 14 days from the date on which he communicated the withdrawal. The deadline is considered respected if the Customer sends the goods before the expiry of the 14 days. The right of withdrawal also lapses in case of substantial defect of the returned product (lack of internal packaging and / or documentation and / or original packaging of the manufacturer; absence of integral elements and accessories of the product; damage; unsuitable state of return) and in general in case of non-compliance with the above conditions. In all cases of forfeiture of the right of withdrawal, the Seller will return the goods to the Customer who will not be entitled to any refund.

8) PACKAGING: The goods are delivered in its constituent elements to be assembled on site. The packaging will be carried out at the full discretion of the Seller who reserves the right to evaluate the optimal shipping method, and unless specific agreements entered into with the Buyer. The packaging considered standard, provides for the positioning of the material in boxes or on pallets, with possible subsequent wrapping with stretch film or bubble wrap. The Company reserves full freedom in the affixing of labels and / or in sending useful instructions to make the materials identifiable during the work. The packaging and related protective materials are to be disposed of by and at the expense of the Buyer.

9) WARRANTY: The quality and integrity of the floors made by La Brenta S.r.l. are guaranteed on condition that the product receives proper storage and maintenance, in accordance with what is specified in the Installation and Maintenance Manual provided by the Seller.

Unless otherwise agreed in writing, the Seller guarantees the goods sold for a period of two years from the date of purchase under the following conditions:

a) obvious defects must be highlighted on the carrier's delivery notes upon receipt of the goods. In the case of packaged material, the Purchaser is obliged to unpack the goods and report all evident defects within 7 days of delivery. The defect, or hidden defect, must be reported by the Buyer to the Seller in writing within 8 days of discovery and in any case before the installation of the material.

b) parts subject to wear are excluded and in all cases of non-observance of the installation instructions and those of use and maintenance provided by the Seller;

c) the Purchaser will be responsible for damage caused to the goods due to bad storage or negligence on his part. The Seller assumes no responsibility for damage caused to the goods before or after installation.

d) Within the warranty period, the Purchaser must exclusively contact the Seller or whoever expressly and previously authorized by him, for technical interventions of any kind, on the goods supplied; in the event that this does not happen, any guarantee will immediately expire.

e) Any claims for damages will not be recognized. However, if the Purchaser notices obvious defects during installation, he must immediately suspend the work and inform the Seller, no later than 2 days from the discovery, under penalty of losing all his rights. Once the goods have been placed, no objection can be made due to obvious defects. The Seller's obligations will be limited to the collection and replacement of the material recognized as defective.

Any disputes will never entitle the Buyer to suspend or delay payments. In the event of a dispute, La Brenta S.r.l. will comply with the UNI 11265 standard.

In any case, the following are excluded from the guarantee:

- manifestations directly related to the proper and natural characteristics of the type and selection of the guaranteed product or of the raw materials used for its construction, including all normal deterioration, effects of use;
- defects of a purely aesthetic nature or of subjective evaluation, which do not in any way compromise the normal functionality of the guaranteed product;
- defects or faults known to the Buyer at the time of purchase;
- damage deriving from inadequate conservation or storage of the material outside spaces under the responsibility of the Producer;
- damage due to installation errors, including damage deriving from inadequacy of the substrate (with reference to the correct geometric, mechanical, hygrometric conditions, etc.) or attributable to defects, inadequacy or incompatibility of the subsidiary materials used for the application or the finishing of the insured items (glues, paints, etc.);
- damage due to incorrect maintenance or improper use of the guaranteed products;
- damages produced or aggravated by intent or negligence by the Buyer or by third parties unrelated to the responsibility of the Manufacturer;
- damage deriving from other external causes of any nature (spillage of water in general, falling objects, infiltration of humidity, alteration of normal climatic conditions, by chance or force majeure) and in any case not directly attributable to manufacturing defects of the products guaranteed.

Defect assessment procedure:

The Purchaser who detects defects in the product included in the validity of this guarantee, in order to make their effects operational, must:

- immediately notify the Producer by registered letter with return receipt;

- send the Manufacturer as soon as possible (in any case no later than 8 days from the initial manifestation of the defect under penalty of forfeiture) a detailed written report by registered letter with acknowledgment of receipt, complete with photographic documentation and any other element useful for correct assessment of the case.

The Producer, on the basis of the written report received, is required to:

- express their relevant preliminary opinion by means of a written communication to be sent to the Buyer within 15 days from the date of receipt of the aforementioned report. If the information collected is not sufficient, before expressing itself on the matter, the Producer reserves the right to request an integration of information through telephone contact or inspection of its external representatives (local dealer, area agent, expert expert, etc.) .

If the relevant preliminary opinion is positive (recognition of defects covered by the guarantee), the restoration procedure is immediately initiated, according to the established procedures.

If the relevant preliminary opinion is negative (lack of verification of defects covered by the guarantee) and the reasons adopted are not considered sufficient, the Purchaser may request the Manufacturer to express a definitive judgment through direct on-site inspection of the Seller's Technical Assistance Service. -Producer. The activation of this procedure is subject to the prior payment, by the Buyer, of a security deposit of Euro 400.00 (four hundred / 00) to partially cover the costs of intervention, which will be fully returned in the event that the final judgment (challenging response) should then be positive.

Recovery procedure

The verification of defects covered by the guarantee commits the Manufacturer to restore the floor by repairing or replacing the affected elements, within the limits and under the conditions indicated below.

The repair of the portion of the floor found to be defective, or its replacement, if repair is impossible, takes place at the expense of the Manufacturer through trusted personnel, and in the shortest possible time, according to agreements to be established directly with the Buyer.

Any evaluation and decision about procedures and technical procedures for carrying out works is left to the unquestionable judgment of the Seller-Manufacturer's Technical Assistance Service, which assumes the responsibility of

The Manufacturer undertakes to make available free of charge any new materials, needed to replace the defective ones, and the manpower necessary to carry out the restoration work.

The costs related to any changes, improvements or extraordinary work services requested by the Buyer are not included in the warranty obligations and are to be assessed separately on the basis of specific agreements. Only material and direct damage to the items guaranteed is subject to this warranty, with the exclusion therefore of all intangible, indirect or any other damage not expressly mentioned, such as disassembly, displacement and reassembly of fixtures and furnishings, loss of enjoyment of the clubs, hotel nights, etc.

Individual parquet strips that show defects detectable when the packages are opened, must be reported before laying the floor, to be replaced if necessary, and must be strictly excluded from assembly. Failure to comply with this simple precaution can easily lead to a considerable worsening of the damage and the related restoration costs. The responsibility for a negligent behaviour in this sense and to be referred directly or indirectly (also through third parties in charge), only to the Buyer and therefore relieves the Manufacturer of the portion of additional charges that may be consequent, thus voiding the guarantee in question.

Territorial limitation

The guarantee given is valid in the territories of the Italian Republic, the Republic of San Marino and the Vatican City State.

10) PAYMENTS: The payment terms will be determined by the seller and the buyer and indicated in the order confirmation. Any collection costs will be charged and invoiced to the Buyer. The Buyer will not be able to suspend, delay or modify payments for disputes, reports of defects or faults and / or for any dispute. Payments must be made to the domicile of the Company, the transmission of the sums due, whatever the means chosen, remains the responsibility of the debtor. It is understood that the issue of securities, bills, checks, transfers, etc. it does not constitute a novation of the original relationship. The non-payment of the Buyer even for a single supply, or any disputes with charges not agreed upon, will give the Company the right to suspend further supplies or to terminate the contract ipso jure without the Buyer being able to claim any right of course and to retain any sums collected as a penalty, without prejudice to compensation for greater damage.

Furthermore, the delay in payment will make immediately payable any amount due by the Buyer in instalments (if agreed), which will have an interest on arrears calculated as per DL n.192 of 2012, without prejudice to the right of the Seller to declare the Contract terminated. and claim compensation for damages, after 15 days from the due date for payment.

11) INSOLVENCY AND RETENTION OF TITLE: The Buyer acknowledges and accepts that the Seller pursuant to art. 1523 cod. civ. reserves the ownership of the goods purchased until the payment of the last instalment of the price or of the last bill or title. During this period, the Purchaser will assume the obligations and responsibilities of the custodian and will not be able to alienate, give into use, let these products be seized or seized without declaring ownership of the Seller and giving immediate notice to the latter by registered letter with return receipt. In case of instalment or deferred payment, failure to pay a single instalment, or the insolvency of a single deadline, will result in the forfeiture of the benefit of the term pursuant to art. 1186 of the Italian Civil Code with the faculty for the Seller, at its sole discretion, to demand the entire credit or to decide for the contextual and immediate termination of the contract. The Seller may also block any existing order until the overdue debt position is settled. In the event of delayed payment on the agreed deadlines, interest on arrears will take effect pursuant to Legislative Decree 231/2002. The default interest at the current legal rate and the bank charges incurred for outstanding payments will therefore be subject to systematic invoicing.

12) RIGHT OF SUBCONTRACTING: If the contract provides for the installation, the Seller reserves the right to entrust this assignment and / or other ancillary services to the mere supply, to companies, artisans, freelancers, individual entrepreneurs, cooperatives and / or other subjects third parties of its unquestionable approval, without prejudice to the qualitative and professional requirements and the safety standards provided for by the law in force. With regard to this assignment, the Seller reserves the right to enter into a specific contract with the person in charge.

13) DISPUTES: For any dispute concerning the interpretation, execution or termination of this contract is subject to the law and jurisdiction of the Italian State and the territorial jurisdiction is devolved exclusively to the Court of Padua (PD) in whose district the Seller has its registered office. The contract and these conditions are drawn up in Italian which will prevail in case of divergence with the translation into other languages.

14) REVERSE CHARGE: Taking into account the response provided by the Inland Revenue on the occasion of the videoconference of 20 January 2007 in point 3.6 "Reverse Charge": construction and installation of fixtures ", we inform you that our Company has the ATECOFIN code 28.75.2 section D is therefore not attributable to the construction sector, therefore, it is not subject to the reverse-charge regardless of the type of contract that binds us to our client.

15) JOINT RESPONSIBILITY FOR CONTRACTS: Pursuant to Circ. ag. Revenue 40 / E of 8.10.2012 La Brenta S.r.l. undertakes at the simple request of the customer to provide a self-certification of the fulfilment of all obligations due in tax, remuneration and social security matters. On the other hand, no statement sworn by the professional will be issued.

16) SELF-PROMOTION: It should be noted that Brenta Srl, for the purpose of self-promotion, reserves the right to freely use on its website and / or brochures and / or conferences and / or any other situation of a promotional nature, the images of all the works created.

17) CONFIDENTIALITY AND TRADEMARKS

The Purchaser is required to observe the most absolute confidentiality on all information of a technical nature (such as, merely by way of example, drawings, prospectuses, documentation, formulas and correspondence) and of a commercial nature (including contractual conditions, prices of purchase, payment conditions, etc ...) learned in execution of the contract. The obligation of confidentiality is assumed throughout the duration of the contract as well as for the period following its execution. In any case of non-compliance with the obligation of confidentiality, the defaulting party is required to compensate the other for all damages, to be proven, that may arise.

The use of trademarks, ornamental models and intellectual works in general, in any form or mode of expression (by way of example, images, photos, drawings, films, etc.) constituting the intellectual property of the Seller, through any means, (to example, radio, press, video, internet, etc.) is strictly prohibited. Any exception to this prohibition, even if only partial, must be authorized in writing, case by case, by the Seller.

Pursuant to art. 1341 and following of the Italian Civil Code the Buyer declares to accept and expressly sign all the clauses contained in the General Conditions of Sale and specifically Articles 1. ORDERS; 2. VALIDITY; 3. SALE PRICES; 4. DELIVERY; 5. TRANSPORT; 6. FAILURE TO COLLECT GOODS; 7. RIGHT OF WITHDRAWAL; 8. PACKAGING; 9. WARRANTY; 10. PAYMENTS; 11. INSOLVENCY AND RETENTION OF OWNERSHIP; 12. RIGHT OF SUBCONTRACTING; 13. DISPUTES; 14. REVERSE CHARGE, 16 JOINT LIABILITY OF THE PARTIES, 17 SELF-PROMOTION, 18. CONFIDENTIALITY AND TRADEMARKS.



Each surface can be made using wood that is not included in the pricelist.
In addition, to all our proposals you can also ask for add inlays with other materials, such as:



Leather



Copper



Brass, mable

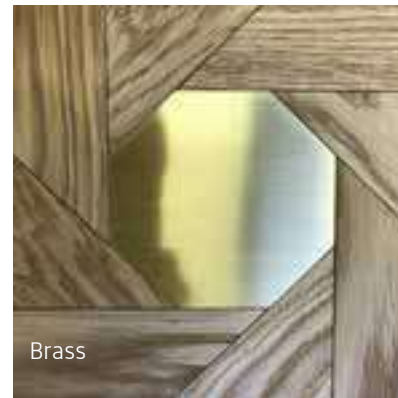

Brass

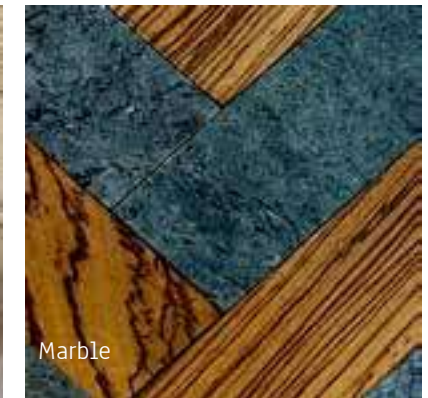

Marble