



# International Food & Drink Event 2024



**London - ExCel 25<sup>th</sup> - 27<sup>th</sup> March 2024**

**Italian Pavilion Stands: 2011 2031 2051 2071 2081**

[madeinitaly.gov.it](http://madeinitaly.gov.it)



Ministry of Foreign Affairs  
and International Cooperation

**ITCA**   
ITALIAN TRADE AGENCY

  
THE EXTRAORDINARY  
ITALIAN TASTE



## TRADE AND INVESTMENT

### OPEN DOORS TO A WORLD OF OPPORTUNITIES

L'ICE-Agenzia per la promozione all'estero e l'internazionalizzazione delle imprese italiane è l'organismo attraverso cui il Governo favorisce il consolidamento e lo sviluppo economico-commerciale delle nostre imprese sui mercati esteri. Agisce, inoltre, quale soggetto incaricato di promuovere l'attrazione degli investimenti esteri in Italia.

Con una organizzazione dinamica motivata e moderna e una diffusa rete di uffici all'estero, l'ICE svolge attività di informazione, assistenza, consulenza, promozione e formazione alle piccole e medie imprese italiane. Grazie all'utilizzo dei più moderni strumenti di promozione e di comunicazione multicanale, agisce per affermare le eccellenze del Made in Italy nel mondo.

ITA - Italian Trade Agency is the Governmental agency that supports the business development of our companies abroad and promotes the attraction of foreign investment in Italy.

With a motivated and modern organization and a widespread network of overseas offices, ITA provides information, assistance, consulting, promotion and training to Italian small and medium-sized businesses. Using the most modern multi-channel promotion and communication tools, it acts to assert the excellence of Made in Italy in the world.



Italian Trade Agency 

@ITAttradeagency 

[www.ice.it](http://www.ice.it)

ITA - Italian Trade Agency 

@itatradeagency 

# FLOORPLAN

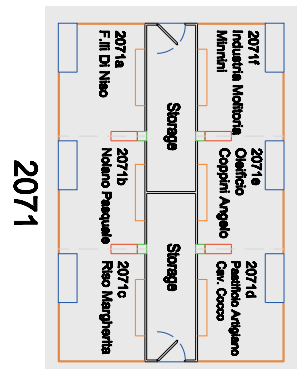
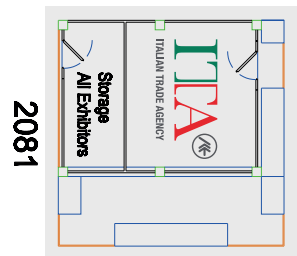
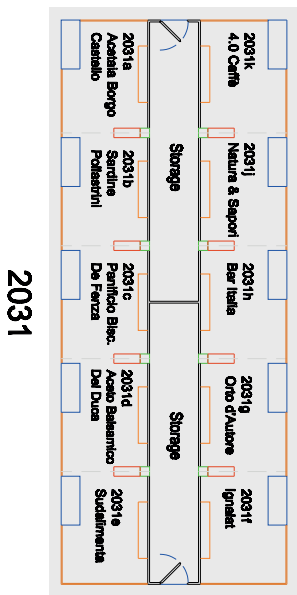
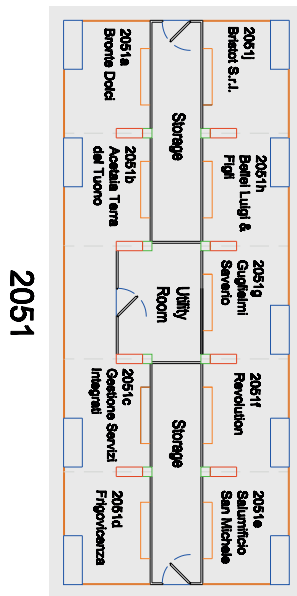
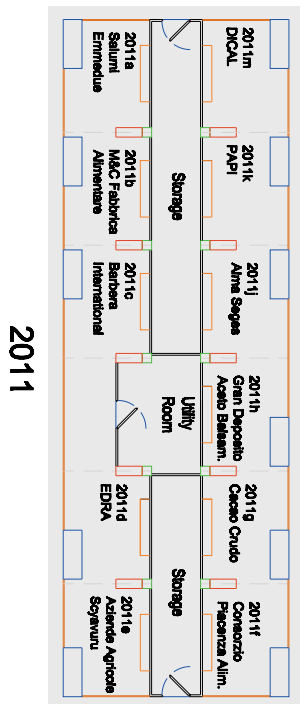

# EXHIBITOR LIST

STAND		PAGE NUMBER
<b>2011</b>		
a	• SALUMI EMMEDUE	9
b	• ALICA	10
c	• BARBERA INTERNATIONAL S.R.L.	11
d	• E.D.R.A. SRL	12
e	• SCYAVURU SRL	13
f	• FORMEC BIFFI	14
g	• CACAO CRUDO	15
h	• ACETAIA GIUSTI	16
j	• ALMA SEGES	17
k	• PASSIONE PER IL FOOD	18
m	• LOLLOCAFFÈ - DICAL S.R.L.	19
<b>2031</b>		
a	• ACETAIA BORGO CASTELLO	21
b	• SARDINE POLLASTRINI DI ANZIO	22
c	• PANIFICIO E BISCOTTIFICIO DE FENZA	23
d	• ACETO BALSAMICO DEL DUCA DAL 1891	24
e	• TIBERINO 1888 - GOURMET ITALIAN MEALS	25
f	• CASEIFICIO IGNALAT	26
g	• ORTO D'AUTORE	27
h	• FOX BAR ITALIA	28
j	• NATURA & SAPORI TARTUFO	29
k	• CAFFÈ QUARANTA	30
<b>2051</b>		
a	• BRONTEDOLCI	32
b	• ACETAIA TERRA DEL TUONO SRL	33
c	• GESTIONE SERVIZI INTEGRATI SRL	34
d	• FRIGOVICENZA S.R.L.	35
e	• SALUMIFICIO SAN MICHELE SPA	36
f	• REVOLUTION NEW FOOD - GLUTEN FREE	37
g	• OLIO GUGLIELMI	38
h	• ACETAIA BELLEI - BALSAMIC VINEGAR OF MODENA	39
j	• BRISTOT SRL	40
<b>2071</b>		
a	• AGRICOLA DI NISO	42
b	• NOLANO	43
c	• RISO MARGHERITA	44
d	• PASTIFICIO ARTIGIANO CAV. GIUSEPPE COCCO	45
e	• OLEIFICIO COPPINI ANGELO S.P.A.	46
f	• INDUSTRIA MOLITORIA MININNI SRL	47

## INDEX BY CATEGORY

### BAKED PRODUCTS

ACETO BALSAMICO DEL DUCA DAL 1891 .....	24
BRISTOT SRL .....	40
BRONTEdolCI .....	32
INDUSTRIA MOLITORIA MININNI SRL .....	47
PANIFICIO E BISCOTTIFICIO DE FENZA .....	23
PASSIONE PER IL FOOD .....	18
REVOLUTION NEW FOOD - GLUTEN FREE .....	37

### CANNED PRODUCTS

SARDINE POLLASTRINI DI ANZIO .....	22
------------------------------------	----

### CHARCUTERIE & MEAT PRODUCTS

PASSIONE PER IL FOOD .....	18
SALUMI EMMEDUE .....	9
SALUMIFICIO SAN MICHELE SPA .....	36

### CHEESES

CASEIFICIO IGNALAT .....	26
--------------------------	----

### CHOCOLATE & CONFECTIONERY

ACETO BALSAMICO DEL DUCA DAL 1891 .....	24
BRONTEdolCI .....	32
CACAO CRUDO .....	15

### COFFEE

CAFFÈ QUARANTA .....	30
LOLLOCAFFÈ - DICAL S.R.L. ....	19

### CONDIMENTS (VINEGAR)

ACETAIA BELLEI - BALSAMIC VINEGAR OF MODENA .....	39
ACETAIA BORGO CASTELLO .....	21
ACETAIA GIUSTI .....	16
ACETAIA TERRA DEL TUONO SRL .....	33
ACETO BALSAMICO DEL DUCA DAL 1891 .....	24

### FROZEN

FRIGOVICENZA S.R.L. ....	35
INDUSTRIA MOLITORIA MININNI SRL .....	47
PASSIONE PER IL FOOD .....	18
REVOLUTION NEW FOOD - GLUTEN FREE .....	37

### FRUIT AND/OR VEGETABLES

BARBERA INTERNATIONAL S.R.L. ....	11
E.D.R.A. SRL .....	12
NOLANO .....	43
ORTO D'AUTORE .....	27
PASSIONE PER IL FOOD .....	18

### GLUTEN FREE

REVOLUTION NEW FOOD - GLUTEN FREE .....	37
---	----

## INDEX BY CATEGORY

### JAMS

ACETO BALSAMICO DEL DUCA DAL 1891 .....	24
ALMA SEGES .....	17
ORTO D'AUTORE .....	27
SCYAVURU SRL .....	13

### OIL

AGRICOLA DI NISO .....	42
OLEIFICIO COPPINI ANGELO S.P.A. ....	46
OLIO GUGLIELMI .....	38

### PASTA

ACETO BALSAMICO DEL DUCA DAL 1891 .....	24
ALICA .....	10
PASTIFICIO ARTIGIANO CAV. GIUSEPPE COCCO .....	45

### PRESERVED VEGETABLES

E.D.R.A. SRL .....	12
NOLANO .....	43

### READY MADE

E.D.R.A. SRL .....	12
FRIGOVICENZA S.R.L. ....	35
GESTIONE SERVIZI INTEGRATI SRL .....	34
TIBERINO 1888 - GOURMET ITALIAN MEALS .....	25

### RICE

RISO MARGHERITA .....	44
-----------------------	----

### SAUCES

ACETAIA TERRA DEL TUONO SRL .....	33
ALMA SEGES .....	17
BRONTEdolCI .....	32
E.D.R.A. SRL .....	12
FORMEC BIFFI .....	14
NOLANO .....	43
ORTO D'AUTORE .....	27
SARDINE POLLASTRINI DI ANZIO .....	22
SCYAVURU SRL .....	13

### SNACKS

FOX BAR ITALIA .....	28
PANIFICIO E BISCOTTIFICIO DE FENZA .....	23
REVOLUTION NEW FOOD - GLUTEN FREE .....	37

### SPREADS

ALMA SEGES .....	17
BRONTEdolCI .....	32
FORMEC BIFFI .....	14
SCYAVURU SRL .....	13

### TRUFFLE PRODUCTS

NATURA & SAPORI TARTUFO .....	29
-------------------------------	----



## STAND 2011a

✉ [export@salumiemmedue.it](mailto:export@salumiemmedue.it)

🌐 [www.salumiemmedue.it/](http://www.salumiemmedue.it/)

☎ +39 0971 995850

🏠 C.da Serralta, Picerno, PZ,  
85055

REGION: Basilicata

Contact Person:

**Verdiana Visco**

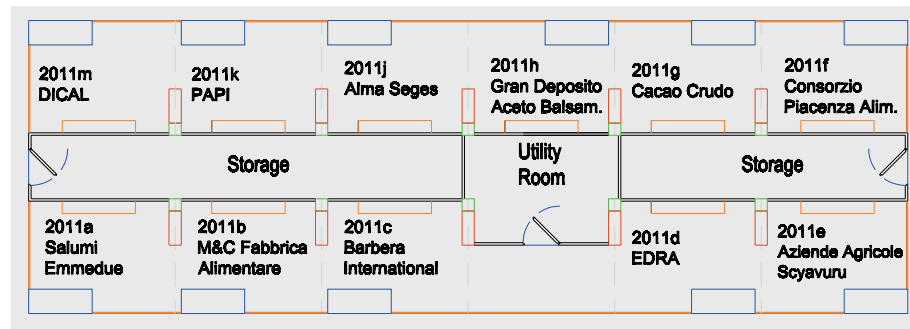

2011

## SALUMI EMMEDUE

Products presented:

**Sausages, salami, bacon**

Company profile:

**Salumi Emmedue** is a family business in the Basilicata region which produces 100% Italian Lucanica sausages, ham and salami. Its key characteristics are the experienced staff, the respect of delivery times and the genuineness of products thanks to the deep connection with the territory.

The company accurately chooses spices so as to create a balance between the ancient tradition and modern technologies. By doing so, Salumi Emmedue is able to provide high quality meat products.



## STAND 2011b

✉ [export@pastalica.it](mailto:export@pastalica.it)  
 🌐 [www.pastalica.it/](http://www.pastalica.it/)  
 ☎ +39 0971485007  
 🏠 Zona Industriale Tito Scalo snc,  
 PZ, 85050  
 REGION: Basilicata

Contact Person:  
**Moreno Maricotti**

## ALICA

Products presented:

**Pasta**

Company profile:

**Alica** is a company specialised in traditional Italian products such as pasta and sauces. Its distinctive feature is the use of 100% Italian selected grains and handmade bronze-drawn pasta, that's worked in a way that allows it to preserve all the nutritional values and healthy proteins. It is also environmentally conscious as it uses eco-friendly fertilisers and recyclable paper for its packaging in order to guarantee products of the highest quality.



## STAND 2011c

✉ [info@barbera-international.com](mailto:info@barbera-international.com)  
 🌐 [www.barbera-international.com](http://www.barbera-international.com)  
 ☎ +39 0957601071  
 🏠 Via Catania, 7, Adrano, CT,  
 95031  
 REGION: Sicilia

Contact Person:  
**Francesco Batticane**

## BARBERA INTERNATIONAL S.R.L.

Products presented:

**Fresh fruit**

Company profile:

The Sicilian company **Barbera International Srl** founded by Alessandro Barbera, a young entrepreneur born in 1981, and located on the slopes of Etna, represents the spearhead of a structured business group, which through various agricultural companies and a cooperative society (all owned) produces and markets the excellence of Sicilian fruit.





## STAND 2011d

✉ info@fantasianapoletana.it

🌐 www.fantasianapoletana.it

☎ +39 3312755257

🏠 Via Napoli 16, Volla, NA,  
80040

REGION: Campania

Contact Person:

**Davide De Cristofaro**

## E.D.R.A. SRL

Products presented:

**Vegetables in oil, tomatoes in jars, ready to eat pasta and dried vegetables**

.....

Company profile:

**Edra Srl** is a family-owned Italian company founded in 1992 which has been the landmark for those who have embarked on a path of rediscovery of traditional flavours, innovating their habits and bringing to the table that quality which is nowadays slowly disappearing. Through 2 different brands "Fantasia Napoletana" and Momangy, traditional hand-made artisanal goods are produced, following a value proposition based on quality and freshness, without the use of any additional flavour or preservatives.

*"Taste the past, love the present"*



SCYAVURU®

STORIE DI GUSTI E SAPORI DI SICILIA

## STAND 2011e

✉ info@scyavuru.com

🌐 www.scyavuru.com

☎ +39 0925 63297

🏠 Via Chiarenza 8, Ribera, AG,  
92016

REGION: Sicilia

Contact Person:

**Rosalia Diliberto**

## SCYAVURU SRL

Products presented:

**Spreadable creams, toppings, sweet sauces, jams and marmalades, pesto sauces, organic jams**

.....

Company profile:

**Scyavuru** is an Italian manufacturing company which mainly produces spreadable creams, toppings, sauces, marmalades and jams. We offer a large range of products for the food service as well as for the retail sector.

The company's main goal is to satisfy every customer's needs by providing them with quality products for the preparation of delicious and tasty recipes.

Our company is IFS, BRC, Halal and Kosher certified.



## STAND 2011f

✉ [export@formec.it](mailto:export@formec.it)  
 🌐 [www.biffi1852.it/en](http://www.biffi1852.it/en)  
 ☎ +39 0377 45401  
 🏠 Via Piacenza, 20,  
 San Rocco al Porto, LO, 26865  
 REGION: Lombardia

Contact Person:  
**Andrea Ravarino**

## FORMEC BIFFI

*Member of the Consorzio Piacenza Alimentare*

Products presented:

**Chilled and stable pasta sauces and other spreadables**

Company profile:

Established at the end of the 60s, **Formec Biffi** is a leading Italian company in the food market. Its dynamism has led it to become one of the largest Italian producers of sauces.

The 25 production lines are one of the company's major assets that allows for a unique and tailor made production flexibility, that nowadays includes more than 100 specialties of pasta sauces and other spreadables, 1600 items and over 470 recipes.



# CACAO CRUDO

MODERN PLEASURE

## STAND 2011g

✉ [info@cacaocrudo.it](mailto:info@cacaocrudo.it)  
 🌐 [www.cacaocrudo.it](http://www.cacaocrudo.it)  
 ☎ +39 0695 38218  
 🏠 Via Prenestina Nuova, 86,  
 Palestrina, RM, 00036  
 REGION: Lazio

Contact Person:  
**Daniele Dell'Orco**

## CACAO CRUDO

Products presented:

**Raw organic chocolate, fruit bars, pralines and other chocolate and cacao products**

Company profile:

**CACAO CRUDO** is a new way to produce and savour chocolate.

To preserve the precious qualities of the cacao and the other ingredients we are constantly seeking new production methods and new ways to enjoy it.

CACAO CRUDO is the first manufacturer of raw chocolate in Italy. We use the high-quality cacao Criollo variety directly from our supply chain in the Peruvian Amazon and we never process it above 45 °C.

Our project was born from an ethical and sustainable vision of food with the aim of offering a product that is both tasty and healthy.





## STAND 2011h

✉ [claudia.rovituso@giusti.it](mailto:claudia.rovituso@giusti.it)

🌐 [www.giusti.com](http://www.giusti.com)

☎ +39 0598 40135

🏠 Strada Quattro Ville 155,  
Modena, MO, 41123  
REGION: Emilia-Romagna

Contact Person:

**Claudia Rovituso**

## ACETAIA GIUSTI

### Products presented:

**Balsamic vinegar of Modena IGP, traditional Balsamic Vinegar of Modena DOP, sweet and sour dressings, gourmet condiments, gourmet specialties, vermouth, glazes**

### Company profile:

**Acetaia Giusti** is the oldest producer of Balsamic Vinegar of Modena and a global reference for high-quality Balsamic Vinegar.

Founded in 1605 and currently led by the 17<sup>th</sup> family generation, Giusti distinguishes itself through deep loyalty to the territory and tradition, combined with a continuous investment in people. This genuine vocation aligns with meticulous attention to detail, a pursuit of satisfying beauty, and a commitment to constant evolution, projecting the company into the future.

Distributed in 80 countries, Giusti is present in the best food specialty boutiques, exclusive department stores, and top-tier restaurants, experiencing rapid and constant growth in Italy and worldwide. The history, evolution, and affirmation of the Giusti brand are narrated through the company's spirit of hospitality.

The family Museum in Modena hosts thousands of visitors annually from around the world, guiding them on an unforgettable experiential journey. Additionally, our flagship boutiques in Modena, Bologna, and Milan welcome gourmet enthusiasts seeking a high-quality product that brings a piece of Modenese tradition and culture to the table.



## STAND 2011j

✉ [aristide.palermo@almaseges.com](mailto:aristide.palermo@almaseges.com)

🌐 [www.almasegesfood.com](http://www.almasegesfood.com)

☎ +39 0828 692654

🏠 Via Campolongo, 184, Eboli, SA,  
84025  
REGION: Campania

Contact Person:

**Aristide Palermo**

## ALMA SEGES

### Products presented:

**Jam, pesto, marmalade, fruit nectar, veg sauce**

### Company profile:

Alma Seges was founded 25 years ago and is now one of the largest Associations of growers in Italy.

Producing on more than 1,000 hectares we are one of the main suppliers of F&V to major Mass Retail across Europe. In 2020 we started processing our top quality fresh fruit & vegetables into genuine and additive-free preserves; all the creations are based on recipes from the 2 Michelin stars Chef Gennaro Esposito. Being growers we do not need to purchase the raw material for our preserves, but we can every day select the best quality and process it the same day of harvest. This allows us to produce without using any preservatives or additives, to obtain the most natural Jams, Veggy Sauces and Fruit Nectars which are truly artisanal made and this can be noticed at very first taste.

Distribution inside and outside Europe is just beginning, but all our line is available to be purchased on our e-shop on [www.almasegesfood.com](http://www.almasegesfood.com)

To know more about the main Company visit [www.almaseges.com](http://www.almaseges.com)



## STAND 2011k

✉ s.serafini@passioneperilfood.it

🌐 www.passioneperilfood.com

☎ +39 0664 007326

🏠 Viale Giulio Agricola 138/140,  
Roma, RM, 00174  
REGION: Lazio

Contact Person:  
**Sara Serafini**

## PASSIONE PER IL FOOD

### Products presented:

**Table olives and lupin beans, dried fruit, pastries and biscuits, chestnuts, marrons and deli meats**

### Company profile:

**Passione per il Food** is a strategic and business consulting agency dedicated to Italian food & beverage companies. Our agency was born thanks to the intuition of the leader and founder Giuseppe Pepe' Sciarria who has 30 years of experience in the food & beverage industry. Over the years we partnered with many Italian producers of authentic agri-food & wine excellences. Our goal is to connect them with buyers, importers and distributors both in the retail and food service sectors around the world.

Our young and dynamic team has selected only the best Made in Italy products to create a customised catalogue and whet the appetite of international consumers.

Our product portfolio includes deli meats, table olives and lupin beans, dried fruit, Pinsa romana bases (fresh and frozen), pastries & biscuits, Lazio native wines (DOC, DOCG, PGI) and coffee.



## STAND 2011m

✉ international@lollocaffe.com

🌐 www.lollocaffe.it

☎ +39 3283 667465

🏠 Via Minichini Abate 11,  
Saviano, NA, 80039  
REGION: Campania

Contact Person:  
**Rosaria Mainella**

## LOLLOCAFFÈ - DICAL S.R.L.

### Products presented:

**Coffee beans, pods and capsules**

### Company profile:

**Lollocaffè** is the main brand of Dical s.r.l, the Neapolitan coffee roasting company, one of the largest in the industry, that specialises in the production of pods, capsules and coffee beans.

The current configuration provides for a production area of 25,000 square metres, importing raw coffee from the most important countries of origin. The availability of wide warehouses, that have recently been expanded further, for the conservation of raw coffee and for the storage and distribution of products through sales offices, allow for a daily production of almost 30,000 kg of roasted coffee, including the daily production 60,000 kg of roasted coffee for the distribution through Horeca, vending and foreign channels. Lollo is an espresso coffee born from the warm hug of Naples, balancing and intensifying the best varieties of Arabic and Robusta, for an unforgettable taste that's pleasant on the palate.



## STAND 2031a

✉ [info@borgocastello.it](mailto:info@borgocastello.it)  
 🌐 [www.acetaiaborgocastello.it](http://www.acetaiaborgocastello.it)  
 ☎ +39 0597 68722  
 🏠 Via Genova, 244,  
 Savignano sul Panaro, MO,  
 41056  
 REGION: Emilia-Romagna

Contact Person:  
**Amelia Vivici**

## ACETAIA BORG CASTELLO

Products presented:

**Balsamic Vinegar of Modena, gourmet condiments and glazes**

Company profile:

**Acetaia Borgo Castello** is a vinegar cellar in the heart of Modena. Our Acetaia produces Balsamic Vinegar of Modena, condiments and glazes. The company is based in Vignola, in the province of Modena, headquarters of the Balsamic Vinegar of Modena PGI Consortium.

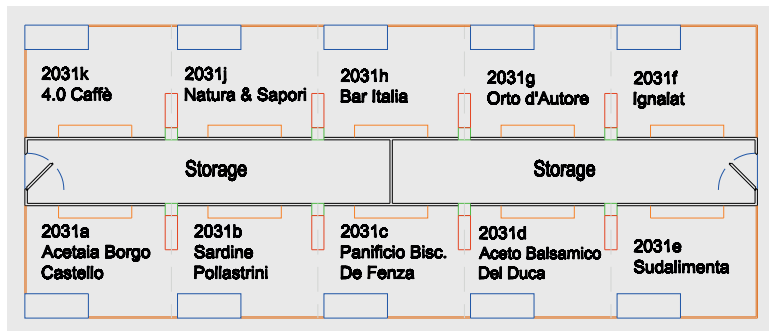

2031



### STAND 2031b

✉ info@sardinepollastrini.com

🌐 www.pollastrinitalia.it

☎ +39 0698 70217

🏠 Viac. Goldoni, 68, Anzio, RM,  
00042

REGION: Lazio

Contact Person:

**Andrea Sepe**

## SARDINE POLLASTRINI DI ANZIO

Products presented:

**Canned Sardines, canned anchovy fillets, ready sardine sauces**

Company profile:

**Sardine Pollastrini di Anzio** was founded in 1889 and since then works only with the highest quality sardines from the Mediterranean Sea, specifically the "Clupea Pilchardus" type, and the "Engraulis encrasicolus" type of anchovies, which is particularly rich of Omega-3 and other nutrients necessary for the physical energetic intake of every human. According to the principles for the respect of the environment, the "Pollastrini" company uses ecological materials for the packing of its products.



### STAND 2031c

✉ export@panificiodefenza.it

🌐 www.panificiodefenza.it

☎ +39 0815 871292

🏠 Via Eduardo de Filippo 17,  
Marano di Napoli, NA, 80016

REGION: Campania

Contact Person:

**Sara La Rovere**

## PANIFICIO E BISCOTTIFICIO DE FENZA

Products presented:

**Baked products and snacks**

Company profile:

The Bakery and **Biscottificio De Fenza** is an Italian family business, founded in 1979 in Naples. From a simple oven, it has evolved into a modern artisan producer of baked products, both conventional and organic, typical of the Campania tradition. The product lines, which all strive for environmental, economic and social sustainability, are subdivided into breakfast items; appetisers / brunch; savoury and sweet snacks; parties/anniversaries.



*Aceto Balsamico del Duca*  
*dal 1891*

## STAND 2031d

✉ export@acetodelduca.it  
✉ vittorio.montaldi@acetodelduca.it  
🌐 www.acetobalsamicodelduca.com  
☎ +39 0594 69471  
🏠 Via Medicine, 2340,  
Spilamberto, MO, 41057  
REGION: Emilia-Romagna  
Contact Person:  
**Vittorio Montaldi**

## ACETO BALSAMICO DEL DUCA DAL 1891

### Products presented:

**Balsamic Vinegar of Modena, Traditional Balsamic Vinegar of Modena, Panettone and Chocolate Pralines with Balsamic Vinegar of Modena, pasta with Balsamic Vinegar of Modena, organic fruit jams with Balsamic Vinegar of Modena, glazes.**

### Company profile:

Since 1891, the history of the Grosoli family has been synonymous with Balsamic Vinegar of Modena. A knowledge that has been handed down from the forefather Adriano for five generations to guarantee a unique product, made from cooked grape musts and selected, high-quality wine vinegars, that has become an irreplaceable dressing for vegetables, meat, and fish. A trusted ally for international chefs to enhance dishes of the most varied cuisines. Remaining faithful to the tradition, and opening itself to new qualitative challenges, the company always proposes a Balsamic Vinegar of Modena, *"at the top of flavour"*.



## STAND 2031e

✉ info@tiberino.com  
🌐 www.tiberino.com  
☎ +39 0805 046008  
🏠 Traversa I di Strada Glomerelli 1/A,  
Bari, BA, 70132  
REGION: Puglia  
Contact Person:  
**Antonio Gattulli**

## TIBERINO 1888 - GOURMET ITALIAN MEALS

### Products presented:

**Italian gourmet one pot meals - Risotti, pasta meals, soups, plant-based meals 100% natural, ready in 3 easy steps**

### Company profile:

**Tiberino** is our family and business name. The name first appeared on the sign of a food specialty shop in 1888. With Tiberino's one-pot meals, you can finally prepare a delicious and healthy meal with no stress and no mess. 3-easy-step cooking and no additional ingredients needed, you only need to add water and oil or butter, we've already taken care of all the rest! Tiberino's one-pot meals contain 100% natural ingredients only, air-dried at a low temperature and expertly blended to ensure a chef-worthy result. With TIBERINO'S ONE-POT MEALS you will enjoy some of the best Italian cuisine without needing to spend hours cooking, washing pots or buying additional, and sometimes expensive, ingredients.



Caseificio dal 1948

Noci (BA), Via G. Di Vittorio 13  
Tel. 080 4972478 [www.ignalat.it](http://www.ignalat.it)

Caseificio Ignalat

## STAND 2031f

✉ [commerciale@ignalat.it](mailto:commerciale@ignalat.it)

🌐 [www.ignalat.com](http://www.ignalat.com)

☎ +39 0804 972478

🏠 Via Giuseppe di Vittorio, 13,  
Noci, BA, 70015  
REGION: Puglia

Contact Person:

**Vincenzo Ignazzi**

## CASEIFICIO IGNALAT

### Products presented:

**Cheeses:** fresh cheeses, naturally smoked in oven (scamorza, burrata, mozzarella, caciocavallo), ripe cheeses, with a focus on fresh cheeses and on several Apulian specialty cheeses as burrata cheese, naturally smoked burrata, frayed burrata (e.g. with black Italian truffle or with basil), mozzarella knot, mozzarella fior di latte and treccia, stracciatella, caciotta, caciocavallo, cacioricotta etc. . Ignalat also produces a fresh line of burrata and mozzarella free from lactose.

### Company profile:

**Caseificio Ignalat** is a family-run company which has been producing premium cheeses in Puglia for three generations, since 1948. Ignalat produces several categories of cheeses using only pasteurised 100% Italian selected cow milk with a focus on fresh and specialty cheeses (e.g. burrata – the flagship of our production and of Apulian dairy tradition - mozzarella, stracciatella, naturally smoked burrata, burrata with truffle, caciocavallo, caciotta, scamorza etc.) Ignalat's premium quality production combines the Apulian master cheese-making tradition with the artisanal production of cheeses which are available in different sizes and packaging in order to satisfy the requirements of customers both in retail and foodservice/ho.re.ca. sales channels. Caseificio Ignalat is compliant with many international food retail standards such as GSFS/ BRC Food Issue 9 Grade AA+ and IFS FoodVers. 7 Higher Level. Many of our cheeses have received awards during previous editions of the World Cheese Awards.



## STAND 2031g

✉ [export@ortodautore.it](mailto:export@ortodautore.it)

🌐 [www.ortodautore.it](http://www.ortodautore.it)

☎ +39 0874 830060

🏠 Contrada Santa Venere, snc,  
Ururi, CB, 86049  
REGION: Molise

Contact Person:

**Luigi D'Arienzo**

## ORTO D'AUTORE

### Products presented:

**Handmade sauces, pesto, legumes, jams**

### Company profile:

Producer of tomato passata and ready sauces, jams (100g of fruit per 100g of product), legumes and oil. Orto d'Autore uses only selected raw materials that have 100% Italian origin, moreover all our products are produced by the own farm company. No additives, no preservatives, gluten and lactose-free. We have conventional, organic and vegan lines.





## STAND 2031h

✉ clienti@foxitalia.com  
 🌐 www.foxitalia.com  
 ☎ +39 3356 355060  
 🏠 Via delle Industrie 9,  
 Città Sant'Angelo, PE, 65013  
 REGION: Abruzzo

Contact Person:  
**Antonio Pavone**

## FOX BAR ITALIA

Products presented:

**Vintage potatoes, tortilla crisps, gourmet snacks, ready-to-drink cocktails**

Company profile:

**Fox Bar Italia** offers the most innovative solutions in the nut & snack market to turn 24 hours into a business opportunity.

Since 1989 the company has been providing its customers with HORECA-RETAIL orders and weekly deliveries, just in logistic time.

Today Fox Bar Italia's products are widespread in the most prestigious sales points and the company is recognized as an ambassador of the Italian aperitif in the world.

We work with thoroughly selected raw ingredients and operate strict production controls in order to guarantee and preserve the integrity of each natural product.



## STAND 2031j

✉ info@naturaesapori.com  
 🌐 www.naturaesapori.com  
 ☎ +39 3398 669624  
 🏠 S.P. 78, 9, Pescolanciano, IS,  
 86097  
 REGION: Molise

Contact Person:  
**Mario Tesone**

## NATURA & SAPORI TARTUFO

Products presented:

**Fresh and processed truffle products**

Company profile:

**Natura & Sapori** is an Italian company highly skilled in the truffle field, one of the rarest products on earth. Natura & Sapori offers a wide variety of fresh truffles that its team directly sources and this allows them to be very competitive in the market. Besides fresh truffles, particularly the white one and the black summer truffle, the company also produces a range of processed truffle based products, like condiments, spreads, ready made sauces, butter, honey, snacks and pasta.



## STAND 2031k

✉ [estero@quarantacaffe.com](mailto:estero@quarantacaffe.com)

🌐 [www.quarantacaffe.it](http://www.quarantacaffe.it)

☎ +39 0831 430059

🏠 Via provinciale per Lecce, 83,  
Brindisi, BR, 72100  
REGION: Puglia

Contact Person:

**Michele Quaranta**

## CAFFÈ QUARANTA

Products presented:

**Coffee beans, coffee pods, capsules, ground coffee**

Company profile:

Founded in 1965, **Caffè Quaranta** is currently among the most important and active companies in southern Italy in the production and marketing of coffee as a result of the experience and tenacity of its founder, Giovanni Quaranta. From a small coffee roastery, it has now transformed in the space of fifty years into a modern and dynamic business complex.

For three generations, following the same meticulous attention to detail, the Quaranta family has selected the best qualities of raw coffee from the various producing countries, selecting the finest coffee beans in the world, to create the best coffee. From these selections we've curated six different blends to satisfy all taste buds across the world. We carefully choose the best plantations and the most precise harvesting system. We follow the coffee throughout its processing and take every precaution to respect quality and aroma. This is our method: a wealth of knowledge at the service of taste, respecting an entirely Italian tradition.

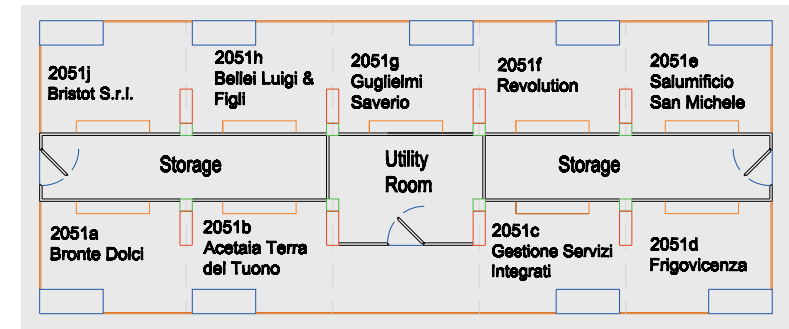

2051



## STAND 2051a

✉ [export@brontedolci.it](mailto:export@brontedolci.it)  
 🌐 [www.brontedolci.it/](http://www.brontedolci.it/)  
 ☎ +39 0957 724090  
 🏠 Viale John Kennedy,  
 stab. 37 zona artigianale,  
 Bronte, CT, 95034  
 REGION: Sicilia

Contact Person:  
**Giuseppe Bellitto**

## BRONTEDOLCI

### Products presented:

**Pistachio-based pastries and delicatessen, following the Sicilian culinary tradition. Nougats, brittle, spreadable creams, pestos, leavened products (broncakes) and holiday items (panettoni and colomba)**

### Company profile:

**Brontedolci**, based in Bronte (Italy), has been producing and marketing pistachio delicacies since 1997, using only the best raw materials (Bronte PDO pistachios, Sicilian almonds, Modica PGI chocolate) and following the Sicilian confectionery tradition.

The range of products includes pestos, spreadable creams, nougats and leavened products. Each product is packaged in a designed box, a perfect combination of design and functionality.

We supply both the retail channel (delicatessens, wineries) and the professional channel (restaurants, ice-cream parlours and patisseries). Despite being a small business, Brontedolci has grown steadily year after year. We export mainly towards Europe, but also to the United Arab Emirates, Canada and the USA.



## STAND 2051b

✉ [roberto@terradeltuono.it](mailto:roberto@terradeltuono.it)  
 🌐 [www.terradeltuono.it](http://www.terradeltuono.it)  
 ☎ +39 0522 343317  
 🏠 Via Paolo Monzani 5,  
 Reggio Emilia, RE, 42122  
 REGION: Emilia-Romagna

Contact Person:  
**Roberto Zini**

## ACETAIA TERRA DEL TUONO SRL

### Products presented:

**Balsamic Vinegar of Modena, pearls of Balsamic and fruity pearls, white Balsamic condiment, sphere with Balsamic Vinegar to grate, crystals of Balsamic, fruity balsamic condiments, balsamic glazes, gourmet sauces, other food innovations**

### Company profile:

**Terra del Tuono** is a very ancient Balsamic vinegar factory, seated in Italy since 1892, and still family owned, carrying on the tradition of the authentic Italian Balsamic Masters from father to son. Our mission is to produce some unique Balsamic specialties, as well as Balsamic vinegar of our traditions.

The process is totally carried out inside our company. We produce our Balsamic vinegars and condiments without caramels, colour agents or other additives.

Moreover, we invest a lot of effort in R&D, to develop and invent innovative products based on Balsamic.

Always, of course, with a great respect for our traditions.



## STAND 2051c

✉ info@annatura.com  
 🌐 www.annatura.com  
 ☎ +39 0690 0997432  
 🏠 Via G. Benzoni 45, Roma, RM,  
 00154  
 REGION: Lazio  
 Contact Person:  
**Fiero Innocenzi**

## GESTIONE SERVIZI INTEGRATI SRL

### Products presented:

Ready to eat cooked V Range vegetables packed in 300 gr containers

.....

### Company profile:

Annatura only chooses fresh seasonal Italian vegetables. Our products are ready to eat because they have been boiled only in water with no preservatives and no flavourings. The products are packed in innovative containers that stay fresh for 30 days in the fridge.



## STAND 2051d

✉ info@frigovicenza.it  
 🌐 www.frigovicenza.it  
 ☎ +39 0444 874111  
 🏠 Via Teonghio n. 71, Origano, VI,  
 36040  
 REGION: Veneto  
 Contact Person:  
**Giulia Bracesco**

## FRIGOVICENZA S.R.L.

### Products presented:

Frozen pizza, frozen filled focaccia

.....

### Company profile:

**Frigovicenza** produces high quality artisan frozen bakery products, such as frozen pizzas and filled focaccias. Our products are characterised by craftsmanship, high digestibility and the use of premium raw materials. We produce under our own brand and private label.

We have IFS FOOD certification.



## STAND 2051e

✉ [luisa.donati@san-michele.it](mailto:luisa.donati@san-michele.it)  
 🌐 [www.san-michele.it](http://www.san-michele.it)  
 ☎ +39 0373 244800  
 🏠 Via Pallavicina, 11, Offanengo,  
 CR, 26010  
 REGION: Lombardia  
 Contact Person:  
**Luisa Donati**

## SALUMIFICIO SAN MICHELE SPA

*Member of the Consorzio Piacenza Alimentare*

### Products presented:

**Parma ham, cured ham, Italian sliced charcuterie**

.....

### Company profile:

The **Salumificio San Michele** was founded 40 years ago in San Michele Tiorre (Felino) in the heart of the Italian Food Valley. We prioritise innovation, quality, safety and the environment, striving to always meet the highest certified safety standards.

A complete supply chain from selection of raw material, ageing, de-boning to slicing, guarantees that all the production phases are always under control.



## STAND 2051f

✉ [info@revolution-food.com](mailto:info@revolution-food.com)  
 🌐 [www.revolution-food.co.uk](http://www.revolution-food.co.uk)  
 ☎ +39 0759 660355  
 🏠 Strada Battifoglia 12/R,  
 Perugia, PG, 06132  
 REGION: Umbria  
 Contact Person:  
**Fabrizio Nicolosi**

## REVOLUTION NEW FOOD - GLUTEN FREE

### Products presented:

**Gluten-free products: flour mix for bread/pizza/cakes, breadcrumbs, dry snacks, cantuccini cookies, classic and wholemeal rusks. As well as a range of frozen gluten-free pizzas, pizza bases, focaccias, hamburger buns**

.....

### Company profile:

Born in 2010 in Perugia (Italy), **Revolution New Food** is a new-generation manufacturer of gluten-free products whose main focus is producing frozen pizzas, pizza bases, focaccias, hamburger buns, gluten-free flours and other dry products.

Our range of award-winning products includes frozen pizzas and focaccias with different toppings to suit every palate. A range of gluten-free and lactose-free mixtures for all your cooking and baking needs.



## STAND 2051g

✉ [export@olioguglielmi.it](mailto:export@olioguglielmi.it)  
 🌐 [www.olioguglielmi.it](http://www.olioguglielmi.it)  
 ☎ +39 0883 591815  
 🏠 Via Canosa 443, Andria, BT,  
 76123  
 REGION: Puglia  
 Contact Person:  
**Angela de Corato**

## OLIO GUGLIELMI

### Products presented:

Premium quality extra virgin olive oil, cold extracted, 100% Italian from the current harvest season 2023/2024. Native varieties from Puglia are presented both as a monovariety or in blends to better serve the most discerning clients. Special flavoured oils, born from the contemporary milling of olives with herbs/citrus, will also be presented. Captivating and innovative packaging!

### Company profile:

**Olio Guglielmi** is a family company producing premium quality Italian extra virgin olive oil from the Puglia region.

Company's philosophy is to combine old traditions passed down from generation with real customers' needs by offering an absolutely excellent product, characterised by many shades of taste and exciting fragrances and also for its innovative and new packaging.

Our strength lies in the control and management of the whole production chain. Family lands cover more than 200 hectares carefully cultivated in Puglia. The olives harvested are milled in their own olive mill, with six different production lines.



## STAND 2051h

✉ [office@bellei.it](mailto:office@bellei.it)  
 🌐 [www.bellei.it/en](http://www.bellei.it/en)  
 ☎ +39 3343 555997  
 🏠 Via Nuova 55/B,  
 Casoli di Ravarino, MO,  
 41017  
 REGION: Emilia-Romagna  
 Contact Person:  
**Giulio Tudini Bellei**

## ACETAIA BELLEI - BALSAMIC VINEGAR OF MODENA

### Products presented:

Balsamic Vinegar of Modena, premium condiments with Balsamic Vinegar of Modena

### Company profile:

**Acetaia Bellei** stands out as a high quality producer of Balsamic Vinegar of Modena and is dedicated to the production of a unique and inimitable product by respecting the most rigorous quality standards and by carefully selecting only Italian and selected local suppliers for its raw materials.





## STAND 2051j

✉ [info@nuovabristot.com](mailto:info@nuovabristot.com)

🌐 [www.bristot1957.it](http://www.bristot1957.it)

☎ +39 0577 940506

🏠 Via di Fugnano 20, San Gimignano, SI, 53037  
REGION: Toscana

Contact Person:

**Gianni Pieragnoli**

## BRISTOT SRL

Products presented:

**Bakery products**

Company profile:

Fruit jams, almonds, sugar, flour, and cocoa, mixed with the finest local products: genuine ingredients and traditional recipes are the secret behind the delicacies we produce every day.

This is how all our cakes, pastries and specialities for various festivities and special occasions are made, and are the result of the dedication of all the people who have used their skills to build the BRISTOT company and keep it alive. This dedication has a simple, genuine taste of authentic Tuscan products.

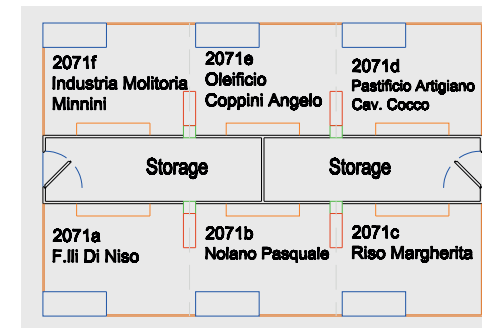

**2071**



## STAND 2071a

✉ info@agricoladiniso.it  
 🌐 www.agricoladiniso.it/  
 ☎ +39 3478 373978  
 🏠 Via G. Amendola 17, Bisceglie,  
 BT, 76011  
 REGION: Puglia  
 Contact Person:  
**Giuseppe Di Niso**

## AGRICOLA DI NISO

### Products presented:

**Extra virgin olive oil Mono variety Coratina, extra virgin olive oil PGI Mono variety Coratina, extra virgin olive oil Mono variety Cima di Melfi**

.....

### Company profile:

For over 100 years, we have taken care of our olive trees in Puglia! From those trees we bring to life our 100% Italian Coratina Cultivar extra virgin olive oil. With a look to the future but still holding on to strong traditions from the past, the Di Niso brothers remain attentive to the evolutions and needs that the market imposes, while always offering a 100% made in Puglia olive oil to their customers.

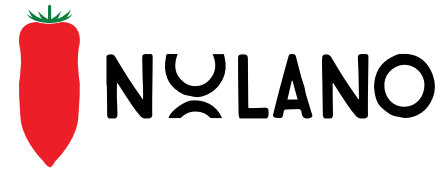

## STAND 2071b

✉ info@nolanoitaly.it  
 🌐 www.nolanoitaly.it  
 ☎ +39 0818 446145  
 🏠 Via Varignano 6, Acerra, NA,  
 80011  
 REGION: Campania  
 Contact Person:  
**Claudio Esposito**

## NOLANO

### Products presented:

**San Marzano Tomato of Agro Sarnese-Nocerino DPO, 100% Italian Whole Peeled Tomatoes, 100% Italian Cherry Tomatoes, 100% Italian Diced Tomatoes, 100% Italian Tomato Puree. 100% Italian Organic Tomato Preserves.**

.....

### Company profile:

The company was founded in 1960 and since then has been the market leader in producing San Marzano tomatoes. The company's recent vertical integration project has facilitated and enabled greater control across all the phases of the supply chain. Our land is volcanic, fertile, and rich in nutritional properties. Every summer, we harvest large quantities of fresh tomatoes, select them, and then process them in specialised transformation plants to guarantee the best products with the highest quality standards.



## STAND 2071c

✉ info@risomargherita.com

🌐 www.risomargherita.com

☎ +39 0161 318481

🏠 Tenuta Margherita Snc,  
Desana, VC, 13034  
REGION: Piemonte

Contact Person:  
**Daide Brusa**

## RISO MARGHERITA

Products presented:

**Rice and risotto**

.....

Company profile:

**Riso Margherita** is a brand of excellence in the Italian rice production panorama. With an extension of almost 300 hectares of property, we produce the best varieties of Italian rice. All stages of production (cultivation, drying, transformation and packaging) are followed and processed directly by our company. The family and the work group portrays tradition and care in every step of the production process to get a unique product of its kind, without compromises.

Our philosophy is to maintain the artisanal manufacturing techniques, innovating but remaining faithful to traditions. The feature that distinguishes us is the "Stone Milling Process", an ancient processing method that allows us to preserve all the organoleptic properties of the outer layers of the rice grain, taking on an amber colour that guarantees more flavour and an exceptional firmness when cooked. This method also allows the germ to remain naturally intact to the rice grain. Our rice is earmarked for specialised gourmet retailers, high-level catering, in Italy and all around the world.



## STAND 2071d

✉ info@pastacocco.com

🌐 www.pastacocco.com/

☎ +39 0872 984121

🏠 Zona Artigianale 15,  
Fara San Martino, CH, 66015  
REGION: Abruzzo

Contact Person:  
**Livio Di Salvatore**

## PASTIFICIO ARTIGIANO CAV. GIUSEPPE COCCO

Products presented:

**Durum wheat semolina pasta**

.....

Company profile:

The Cocco family boasts a family tradition which dates back to 1914. In 1944 **Giuseppe Cocco** took over his father's trade, searching through bomb-site rubble for machine parts used by former pasta-makers. With this machinery, those memories and 'secrets', today the Cocco family produces pasta from that era in the village of Fara San Martino - just as good as it used to be.

What makes the pasta so unique? The excellent physical properties of the spring water from the River Verde and the dry, windy microclimate of the place, perfect for the drying process.



### STAND 2071e

✉ export@coppini.com  
 🌐 www.coppini.com  
 ☎ +39 (0)744 813778  
 🏠 Strada di Recentino, 80, Terni,  
 TR, 05100  
 REGION: Umbria

Contact Person:  
**Valentina Sabatini**

## OLEIFICIO COPPINI ANGELO S.P.A.

Products presented:

Olive oils

.....

Company profile:

The Italian company **COPPINI** has been producing olive oils since 1955.

It is a family-run company, exporting in 45 Countries worldwide. Coppini produces all kinds of extra virgin and olive oils, focusing on quality and on the environment. The company is certified BRC, Organic, IFS, ISO 14001 for the environment, ISO 22005 for evo traceability, Halal, and Kosher.



### STAND 2071f

✉ info@buene.it  
 🌐 www.buene.it  
 ☎ +39 0803 101297  
 🏠 Via Graviscella C.S.1448,  
 Altamura, BA, 70022  
 REGION: Puglia

Contact Person:  
**Vincenzo Di Toma**

## INDUSTRIA MOLITORIA MININNI SRL

Products presented:

Typical Italian and regional baked products like focaccia, ciabattas, pizza bases, pinsa, panzerotti, etc .

.....

Company profile:

The **MININNI Milling Industry** was founded in Altamura in 1877 as a durum wheat mill. Today, re-milled durum wheat semolina has become the basic ingredient of MININNI Buéne products.

The company offers typical baked products of the Italian and regional tradition such as focacce, ciabatte, pizza bases, pinsa, panzerotti, etc. The products are pre-cooked and frozen or refrigerated, ideal for retail and catering.

We are BRC and IFS certified.











**ITCA**   
ITALIAN TRADE AGENCY

**LONDON**

Sackville House, 40 Piccadilly  
London W1J 0DR, UK  
E-mail: [londra@ice.it](mailto:londra@ice.it)  
T +44 (0)20 7292 3910  
[www.ice.it](http://www.ice.it)

@ITALondon 

@ITALondon\_ 

@ITA London Italian Trade Agency 

@italondon\_ 